

# ***Panasonic Broadcast***

## ***AJ-SPD850p*** ***Menu Information***

# Setup (Initial settings)

The memory card recorder's main settings are performed while making selections using a system of menus. If a TV monitor has been connected to the VIDEO OUT 3 connector or SDI OUT 3 connector (optional) on the rear panel and the SUPER switch is set to [ON], the setting menus are displayed on the TV monitor.

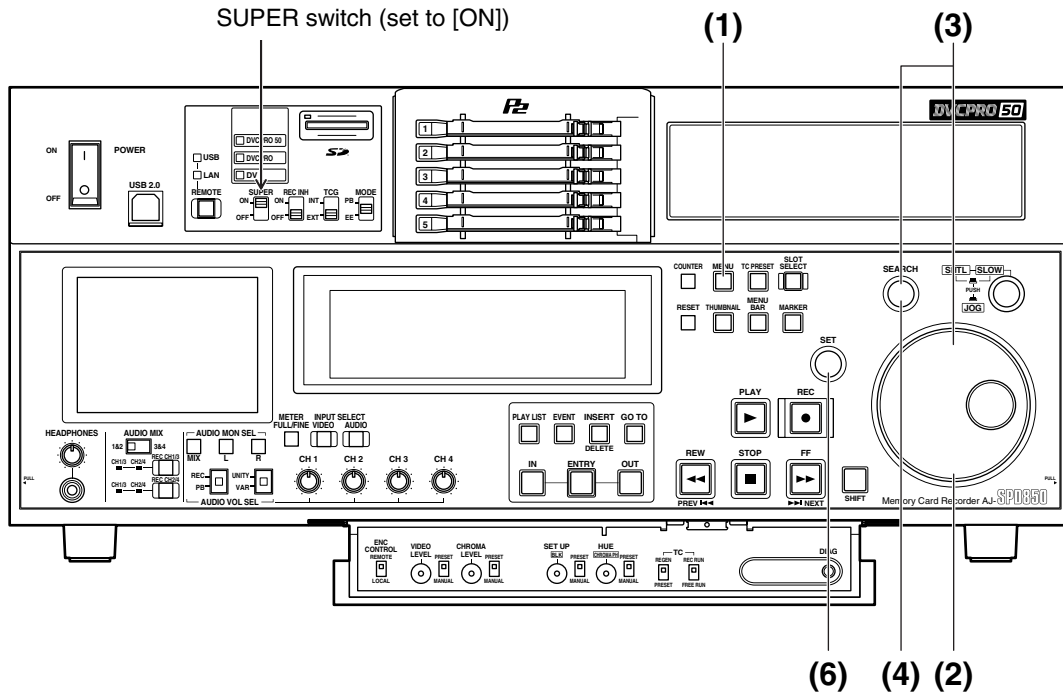

## ■ Changing the settings

### (1) Press the MENU button

The setup menu screen appears on the TV monitor, and the setup menu item number appears on the counter display.

Each time the FF button is pressed (for about 1.5 seconds), the item number and item name are displayed alternately.

(If a setup was performed previously, the screen on which the last change was made is displayed.)

### (2) Turn the search dial to select the item to be set

The menu screen cursor (\*) moves, and the item number on the display flashes.

- When the dial is turned clockwise, the item number is incremented from 001 → 002 → 003 → 004 and so on; conversely, when it is turned counterclockwise, the item number is decremented.

- When the FF button or REW button is pressed while holding down the PLAY button, the next or previous item is selected.

- Whenever possible, limit the use of the search dial to the JOG mode.

### (3) At the position where the change is to be made, turn the search dial while holding down the SEARCH button

The settings on the menu screen and display now flash. When the dial is turned clockwise, the setting number is incremented; conversely, when it is turned counterclockwise, it is decremented.

### (4) Upon completion of the setting, release the SEARCH button

- When the search dial is in the SHTL mode, the item will move unless the dial is set to the center position.

### (5) When other items are to be changed, repeat steps (2) to (4)

### (6) Press the SET button

The changes are stored in the memory.

To disregard the new settings and restore the old settings instead, press the MENU button.

- To return the setup contents to the factory settings (initial settings), press the RESET button while the menu is displayed. The following message is displayed.

```

SETUP - MENU INIT SET
YES<PLAY> / NO<STOP>
    
```

If the PLAY button is now pressed, the factory settings are reinstated.

#### Notes:

- If the RESET button is pressed to restore the factory settings, only the user files currently in use are restored. The other user files remain unaffected.
- The changes made to the SYSTEM menu contents are recorded even by pressing the MENU button to close the menu screen.

# Setup menus

The memory card recorder can hold five user files, each of which has its own specific menu settings, and one of these files can be selected for use.

## ■ Changing the file

- (1) Press the MENU button
- (2) Press the FF button while holding down the DIAG (or SHIFT) button to switch to the next user file or press the REW button while holding down the DIAG (or SHIFT) button to return to the previous user file

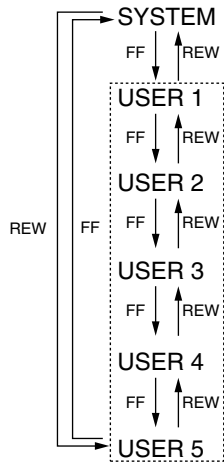

### User files

Each user file contains the following items.

- BASIC
- OPERATION
- INTERFACE
- EDIT
- TIME CODE
- VIDEO
- AUDIO
- V BLANK
- LCD
- MENU

- (3) To enter the selection made in step (2) for the user file which is to be used, press the SET button

The user file is changed and stored in the memory.

### Note:

Since the SYSTEM menu items are not included in user files 1 through 5, first select the user file and switch to the SYSTEM file, and then set the SYSTEM menu items.

## ■ Setting and releasing the lock mode

The lock mode can be set to protect the system file and user file (USER2 to USER5) settings. Once the lock mode is set, no further changes can be made to the settings.

Setting and releasing the lock mode can be set for the system file by using setup menu No. 40 (MENU LOCK) and for the user files by using setup menu No.A03 (MENU LOCK).

- (1) Press the MENU button
- (2) Press the REW or FF button while holding down the DIAG (or SHIFT) button and select the file for which the lock mode is to be set or released

- (3) Turn the search dial

The cursor (\*) on the menu screen is moved to No. 40 (MENU LOCK) for the system file or to No. A03 (MENU LOCK) for a user file.

- (4) Turn the search dial while holding down the SEARCH button to select whether the lock mode is to be set or released

**To set the lock mode:**

Set 0001 (ON) as the setting.

**To release the lock mode:**

Set 0000 (OFF) as the setting.

When the lock mode has been set, "LOCKED" flashes on the menu screen. The counter display stops flashing and remains lighted.

SETUP-MENU	LOCKED
<USER2>	NO.000-0005
*000 P-ROLL TIME	5s
001 LOCAL ENA	STOP
002 CTL DISP	±12h
003 REMAIN SEL	2L
008 DISPLAY SEL	T&STA
009 CHARA H-POS	4
010 CHARA V-POS	18
011 CHARA TYPE	WHITE
012 SYS FORMAT	50M

- (5) Press the SET button

The setting is stored in the memory.

### Notes:

- The lock mode cannot be set for the USER1 file.
- Once set to the lock mode, a file cannot be reset to the factory settings even by pressing the RESET button.

# Setup menus (continued)

## ■ Loading user files

The contents of the USER2, USER3, USER4 or USER5 file can be copied (loaded) into the USER1 file. Also, the contents of the USER1 file can be copied (saved) into the USER2, USER3, USER4 or USER5 file.

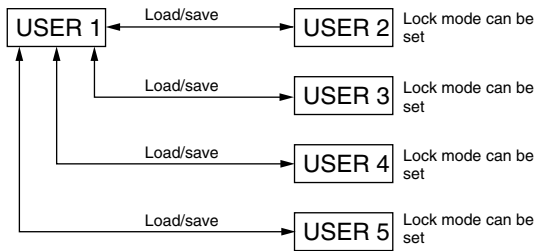

- (1) Press the MENU button
- (2) Press the REW or FF button while holding down the DIAG (or SHIFT) button and select USER1 file
- (3) Turn the search dial to move the cursor (\*) on the menu screen to No. A00 (LOAD)

```

SETUP-MENU  MENU
<USER1>    NO .A00-0000
902 GUI OUTPUT OFF
*A00 LOAD USER2
A01 SAVE USER2
A02 P. ON LOAD OFF
END
    
```

- (4) Turn the search dial while holding down the SEARCH button to select the user file whose contents are to be loaded into USER1
- (5) Press the SET button

The following message appears on the menu screen and counter display.

Menu screen

```

SETUP-MENU  LOAD
USER2 → USER1 OK?
YES<PLAY>/NO<STOP>
    
```

Counter display



The number of the user file selected in step (4) is displayed at ■.

- (6) Press the PLAY button

The settings of the user file selected in step (4) are loaded, and the USER1 menu display appears. If the STOP button is pressed instead, the settings are not changed, and the USER1 menu display appears.

- (7) Turn the search dial to move the cursor (\*) on the menu screen to a number other than No. A00 (LOAD) or No. A01 (SAVE)
- (8) Press the SET button

The USER1 settings are stored in the memory. If the USER1 settings are not to be stored in the memory, do not press the SET button but press the MENU button instead.

## ■ Saving user files

- (1) Press the MENU button
- (2) Press the REW or FF button while holding down the DIAG (or SHIFT) button and select USER1 file
- (3) Turn the search dial to move the cursor (\*) on the menu screen to No. A01 (SAVE)

```

SETUP-MENU  MENU
<USER1>    NO .A00-0000
902 GUI OUTPUT OFF
A00 LOAD USER2
*A01 SAVE USER2
A02 P. ON LOAD OFF
END
    
```

- (4) Turn the search dial while holding down the SEARCH button to select the user file in which the contents of USER1 are to be saved

Those user files which have been set to the lock mode do not appear on the display. If all the user files have been set to the lock mode, the "LOCKED" display appears, and the contents of USER1 cannot be saved into any of the user files.

- (5) Press the SET button

The following message appears on the menu screen and counter display.

Menu screen

```

SETUP-MENU  SAVE
USER1 → USER2 OK?
YES<PLAY>/NO<STOP>
    
```

Counter display

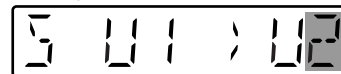

The number of the user file selected in step (4) is displayed at ■.

- (6) Press the PLAY button

The settings of USER1 are saved in the user file selected in step (4) and stored in the memory. If the STOP button is pressed instead, the settings are not changed, and the USER1 menu display appears.

- (7) Turn the search dial to move the cursor (\*) on the menu screen to a number other than No. A00 (LOAD) or No. A01 (SAVE)
- (8) Press the SET button

The USER1 settings are stored in the memory. If the USER1 settings are not to be stored in the memory, do not press the SET button but press the MENU button instead.

## ■ Automatically recalling a user file when turning on the power

If the user file to be loaded is selected in advance using setup menu No. A02 (P. ON LOAD), the file will be automatically loaded into USER1 when the power is turned on.

# Setup menus (continued)

## ■ SYSTEM menu

No./Item	Description
11 SYS SC COAR.	<p><b>Coarse adjustment of system phase:</b> 90 ° units</p> <p><u>0000</u> <u>0</u> <b>Note:</b>            0001 90 If setting operation is            0002 180 performed, the setting            0003 270 value does not return to            factory (default) setting.</p>
12 SYS SC FINE	<p><b>Fine adjustment of system phase:</b>            Variable range ±45 ° or more            -: Advanced, +: Delayed</p> <p>0000 -128 <b>Note:</b>            : : If setting operation is  <u>0128</u> <u>0</u> performed, the setting            : : value does not return to            0255 127 factory (default) setting.</p>
13 SYS H	<p><b>System phase adjustment:</b> 74 ns steps            -: Advanced, +: Delayed</p> <p>0000 -128 <b>Note:</b>            : : If setting operation is  <u>0128</u> <u>0</u> performed, the setting            : : value does not return to            0216 127 factory (default) setting.</p>
14 SCH COARSE	<p><b>SCH phase adjustment:</b> 90 ° units            (The SC phase changes but the H phase does not change.)            -: Advanced, +: Delayed</p> <p>0000 <u>0</u>            0001 90            0002 180            0003 270</p>
15 SCH FINE	<p><b>SCH phase adjustment:</b>            Total variable range: ±45 ° or more            (The SC phase changes but the H phase            does not change.)            -: Advanced, +: Delayed</p> <p>0000 -32            : :  <u>0032</u> <u>0</u>            : :            0064 32</p>

The underlined items indicates the initial setting.

### Video output signal adjustments

The video output signal adjustments are made by using the ENC CONTROL switch on the front panel and selecting the SYSTEM menu item No. 19 (SYS SC/H) settings. A control matrix of the adjustments is shown below.

Setting		Item adjusted	
ENC CONTROL	SYSTEM menu item 19: SYS SC/H	SYSTEM menu item 11: SYS SC COAR. 12: SYS SC FINE 13: SYS H	Front panel (under section) VIDEO LEVEL CHROMA LEVEL SET UP/BLACK HUE/CHROMA PHASE
LOCAL	LOCAL REMOTE	The memory card recorder	The memory card recorder
REMOTE	LOCAL REMOTE	The memory card recorder External encoder remote controller	External encoder remote controller

No./Item	Description
16 AV PHASE	<p><b>This adjusts the audio output phase with respect to the video output:</b>            20.8 µs steps            -: The audio output phase is advanced with respect to the video output.            +: The audio output phase is delayed with respect to the video output.</p> <p>0000 -100            : :  <u>0100</u> <u>0</u>            : :            0200 100</p>
18 SYS H OFFSET	<p><b>System phase adjustment.</b></p> <p>0000 -3 : -13.4 µsec            0001 -2 : -8.96 µsec            0002 -1 : -4.52 µsec            0003 <u>0</u> : 0 sec            0004 1 : +4.52 µsec            0005 2 : +8.96 µsec            0006 3 : +13.4 µsec  <b>Note:</b>            If setting operation is performed, the setting value does not return to factory (default) setting.</p>
19 SYS SC/H	<p><b>This sets whether the system phase is to be adjusted by the memory card recorder or from the external encoder remote controller.</b></p> <p>0000 <b>REMOTE :</b>            The system phase is adjusted from the external encoder remote controller.            0001 <b>LOCAL :</b>            The system phase is adjusted by the memory card recorder.  <b>Note:</b>            This setting does not take effect when LOCAL has been selected by the ENC CONTROL switch on the front panel.</p>

## Setup menus (continued)

### SYSTEM menu

No./Item	Description
30 <b>BRIGHT</b>	<p>This adjusts the brightness of the LCD monitor on the front panel.</p> <p>0000    -7 :        : <u>0007</u>    0 :        : 0014    7</p> <p><b>Note:</b> If setting operation is performed, the setting value does not return to factory (default) setting.</p>
31 <b>CONTRAST</b>	<p>This adjusts the contrast of the LCD monitor on the front panel.</p> <p>0000    -7 :        : <u>0007</u>    0 :        : 0014    7</p> <p><b>Note:</b> If setting operation is performed, the setting value does not return to factory (default) setting.</p>
40 <b>MENU LOCK</b>	<p>This selects whether the system file lock mode is to be engaged or released.</p> <p><u>0000</u> <b>OFF</b> : The lock is released (file data can be changed). 0001 <b>ON</b> : The lock is engaged (file data cannot be changed).</p>

### USER menu <BASIC>

No./Item	Description
000 <b>P-ROLL TIME</b>	<p>This sets the preroll time. The preroll time can be set from 0 to 15 seconds in 1-second increments.</p> <p>0000    0s :        : <u>0005</u>    5s :        : 0015    15s</p>
001 <b>LOCAL ENA</b>	<p>This selects the buttons which can be operated on the front panel when the REMOTE button is lit.</p> <p>0000    <b>DIS</b> : No buttons can be operated. <u>0001</u>    <b>STOP</b> : Only the STOP button can be operated. 0002    <b>ENA</b> : All buttons can be operated.</p>
002 <b>CTL DISP</b>	<p>This selects the 12 or 24 hour display for the CTL counter.</p> <p><u>0000</u>    ±12h : 12 hour display 0001    24h : 24 hour display</p>
003 <b>REMAIN SEL</b>	<p>This selects whether the remaining time or total time is to be displayed in the superimposed display of the VIDEO OUT 3/ SDI OUT 3 connector (optional) signals.</p> <p>0000    <b>OFF</b> : No display. 0001    <b>2L</b> : The remaining time is displayed on the second line. <u>0002</u>    <b>1L</b> : The remaining time is displayed on the first line. 0003    <b>R/TTL</b> : The remaining time is displayed on the first line, and the total time is displayed in the second line.</p> <p><b>Notes:</b></p> <ul style="list-style-type: none"> <li>•When "2L" is selected, the remaining time is not displayed if "TIME" has been selected as the setup menu item No. 008 (DISPLAY SEL) setting.</li> <li>•When "R/TTL" is selected, the total time is not displayed if "TIME" has been selected as the setup menu item No. 008 (DISPLAY SEL) setting.</li> </ul>

The underlined items indicates the initial setting.

# Setup menus (continued)

## ■ USER menu <BASIC>

No./Item	Description
<b>008</b> <b>DISPLAY SEL</b>	<p>This selects what information is to be provided by the time code and other superimposed displays output from the VIDEO OUT 3/SDI OUT 3 connector (optional).</p> <p><b>0000 TIME</b> : Data only. (The data indicates the value for whichever of CTL, TC or UB currently selected by the COUNTER button.)</p> <p><b>0001 T&amp;STA</b> : Data and operation status.</p> <p><b>0002 T&amp;S&amp;M</b> : Data, operation status and mode.</p> <p><b>0003 T&amp;RT</b> : Data and REC TIME</p> <p><b>0004 T&amp;YMD</b> : Data and REC DATE (year/month/day)</p> <p><b>0005 T&amp;MDY</b> : Data and REC DATE (month/day/year)</p> <p><b>0006 T&amp;DMY</b> : Data and REC DATE (day/month/year)</p> <p><b>0007 T&amp;UB</b> : Data and user bit. However, when UB has been selected with the COUNTER button, the time code is displayed after the user bit.</p> <p><b>0008 T&amp;CTL</b> : Data and CTL data. However, when CTL has been selected with the COUNTER button, the time code is displayed after the CTL data.</p> <p><b>0009 T&amp;T</b> : Data and time code.</p> <p><b>0010 VITC</b> : The time code and user bit recorded on the card are displayed.</p> <p><b>Notes:</b></p> <ul style="list-style-type: none"> <li>•Mode display: DVCPRO 50 (50 Mbps) = DVCPRO_50, DVCPRO (25 Mbps) = DVCPRO, DV = DV</li> <li>•An error message appears if a warning or error has occurred when "T&amp;S&amp;M" has been selected as this setting.</li> <li>•The recording duration and recording time and date are displayed when the DV format applies. The operating status is displayed instead when the DVCPRO50 (50 Mbps) or DVCPRO (25 Mbps) format applies.</li> </ul>

No./Item	Description												
<b>009</b> <b>CHARA H-POS</b>	<p>This sets the position of the characters on the horizontal plane for the time code and other superimposed displays output from the VIDEO OUT 3/ SDI OUT 3 connector (optional).</p> <p><b>0000 0</b> : : <b>0004 4</b> : : <b>0016 16</b></p> <p><b>Note:</b> Characters may extend beyond the edges of the screen.</p>												
<b>010</b> <b>CHARA V-POS</b>	<p>This sets the position of the characters on the vertical plane for the time code and other superimposed displays output from the VIDEO OUT 3/ SDI OUT 3 connector (optional).</p> <table style="width: 100%; border: none;"> <tr> <td style="text-align: center;">[525i system]</td> <td style="text-align: center;">[625i system]</td> </tr> <tr> <td style="text-align: center;"><b>0000 0</b></td> <td style="text-align: center;"><b>0000 0</b></td> </tr> <tr> <td style="text-align: center;">: :</td> <td style="text-align: center;">: :</td> </tr> <tr> <td style="text-align: center;"><b>0018 18</b></td> <td style="text-align: center;"><b>0023 23</b></td> </tr> <tr> <td style="text-align: center;">: :</td> <td style="text-align: center;">: :</td> </tr> <tr> <td style="text-align: center;"><b>0022 22</b></td> <td style="text-align: center;"><b>0028 28</b></td> </tr> </table> <p><b>Note:</b> When the DISPLAY SEL setting causes characters to extend beyond the edges of the screen, the setting value is changed so that the characters are automatically displayed in a position on the screen.</p>	[525i system]	[625i system]	<b>0000 0</b>	<b>0000 0</b>	: :	: :	<b>0018 18</b>	<b>0023 23</b>	: :	: :	<b>0022 22</b>	<b>0028 28</b>
[525i system]	[625i system]												
<b>0000 0</b>	<b>0000 0</b>												
: :	: :												
<b>0018 18</b>	<b>0023 23</b>												
: :	: :												
<b>0022 22</b>	<b>0028 28</b>												
<b>011</b> <b>CHARA TYPE</b>	<p>This selects the display type for the superimposed display output from the VIDEO OUT 3/SDI OUT 3 connector (optional) as well as for displays such as the setup menu, etc.</p> <p><b>0000 WHITE</b> : White characters against a black background.</p> <p><b>0001 W/OUT</b> : White characters with a black border.</p>												

The underlined items indicates the initial setting.

# Setup menus (continued)

## ■ USER menu <BASIC>

No./Item	Description
012 SYS FORMAT	<p>This sets the memory card recorder's recording and playback format.</p> <p><u>0000</u> <u>50M</u> : DVCPRO50 (50 Mbps) is selected.</p> <p>0001 <u>25M</u> : DVCPRO (25 Mbps) is selected.</p> <p>0002 <u>DV</u> : DV (25 Mbps) is selected.</p> <p><b>Note:</b> The format complies with the setting of this menu item when the card is ejected.</p>
017 CHARA SIZE	<p>This selects the size of the characters for the superimposed display output from the VIDEO OUT 3/SDI OUT 3 connector (optional).</p> <p><u>0000</u> <u>NORMAL</u> : Standard size</p> <p>0001 <u>LARGE</u> : 4 times larger than the standard size</p> <p><b>Note:</b> When LARGE has been selected, only time data is displayed, regardless of the setup menu No.008 (DISPLAY SEL) setting.</p>

No./Item	Description
069 CLOCK SET	<p>Sets the internal clock time.</p> <p><b>Note:</b> Press the STOP button to display a sub-screen for selecting the line to be recorded. Press the STOP button again to return from the sub-screen.</p>
<b>Sub-screen</b>	
00 YEAR	<p>Sets the year.</p> <p><u>0000</u>    <u>2000</u> :        : <u>0004</u>    <u>2004</u> :        : 0030    2030</p>
01 MONTH	<p>Sets the month.</p> <p><u>0001</u>    <u>JAN</u> :        : 0012    DEC</p> <p><b>Note:</b> If a nonexistent day is set while setting Feb, April, June, September, or November, it is set as the first day of the following month.</p>
02 DAY	<p>Sets the day.</p> <p><u>0001</u>        <u>1</u> :            : 0031        31</p> <p><b>Note:</b> If a nonexistent day is set while setting Feb, April, June, September, or November, it is set as the first day of the following month.</p>
03 HOUR	<p>Sets the hour value. Set the value based on 24-hour clock time.</p> <p><u>0000</u>        <u>0</u> :            : 0023        23</p>
04 MINUTE	<p>Sets the minute value.</p> <p><u>0000</u>        <u>0</u> :            : 0059        59</p>

The underlined items indicates the initial setting.

# Setup menus (continued)

## ■ USER menu <BASIC>

No./Item	Description
<b>05</b>	<b>Sets the time difference from the world standard time.</b>
<b>TIME ZONE</b>	
<b>0000</b>	<b>00:00</b>
<b>0001</b>	<b>+00:30</b>
<b>0002</b>	<b>+01:00</b>
<b>:</b>	<b>:</b>
<b>0050</b>	<b>-00:30</b>
	Refer to the table below, and select the setting which corresponds to the local time.

Time difference	City/region	Time difference	City/region
00:00	Greenwich	+ 13:00	
- 00:30		+ 10:30	Lord Howe Island
- 01:00	Azores	+ 12:00	New Zealand
- 01:30		+ 09:30	Darwin Islands
- 02:00	Central Atlantic time	+ 11:00	Solomon Islands
- 02:30		+ 08:30	
- 03:00	Buenos Aires	+ 10:00	Guam
- 03:30	Newfoundland	+ 07:30	
- 04:00	Halifax	+ 09:00	Tokyo
- 04:30		+ 06:30	Rangoon
- 05:00	New York	+ 08:00	Beijing
- 05:30		+ 05:30	Bombay
- 06:00	Chicago	+ 07:00	Bangkok
- 06:30		+ 04:30	Kabul
- 07:00	Denver	+ 06:00	Dacca
- 07:30		+ 03:30	Teheran
- 08:00	Los Angeles	+ 05:00	Islamabad
- 08:30		+ 02:30	
- 09:00	Alaska	+ 04:00	Abu Dhabi
- 09:30	Marquesas Islands	+ 01:30	
- 10:00	Hawaii	+ 03:00	Moscow
- 10:30		+ 00:30	
- 11:00	Midway Islands	+ 02:00	Eastern Europe
- 11:30		+ 12:45	Chatham Islands
- 12:00	Kwajalein Atoll	+ 01:00	Central Europe
+ 11:30	Norfolk Islands		

### Note:

The clock has an accuracy equivalent to a monthly error of  $\pm 30$  seconds with the power OFF. When the precise time is required, check the time and reset it while the power is ON.

No./Item	Description
<b>070</b>	<b>This selects the TV system.</b>
<b>TV SYSTEM</b>	
	[525i system]                      [625i system]
<b>0000</b>	<b>525      0000</b>
<b>0001</b>	<b>625      0001</b>
<b>0000:</b>	The 525 interlace/59.94 Hz system is selected.
<b>0001:</b>	The 625 interlace/50 Hz system is selected.
<b>Notes:</b>	
	•After this setting is changed, turn off and back on the power again to take it effect.
	•Analog video signals cannot be selected using INPUT SELECT once the TV system has been changed from the factory setting.
	•When the setting is changed, the play list is reset.

## Setup menus (continued)

### ■ USER menu <OPERATION>

No./Item	Description
100 SEARCH ENA	<p>This selects the direct search dial operation.</p> <p><u>0000</u> <b>DIAL</b> : For direct search dial operations.</p> <p><u>0001</u> <b>KEY</b> : Operation is not transferred to the search mode unless the search button is pressed.</p>
101 SHTL MAX	<p>This sets the maximum speed for shuttle operations.</p> <p><u>0000</u> <b>x8</b> : 8x normal speed  <u>0001</u> <b>x16</b> : 16x normal speed  <u>0002</u> <b>x32</b> : 32x normal speed  <u>0003</u> <b>x60</b> : 60x normal speed  <u>0004</u> <b>x100</b> : 100x normal speed</p>
102 FF. REW MAX	<p>This sets the maximum speed for FF and REW operations.</p> <p><u>0000</u> <b>x32</b> : 32x normal speed  <u>0001</u> <b>x60</b> : 60x normal speed  <u>0002</u> <b>x100</b> : 100x normal speed</p>
104 REF ALARM	<p>This selects whether to warn the operator when the REF. VIDEO signal has not been connected.</p> <p><u>0000</u> <b>OFF</b> : Warning is not given.</p> <p><u>0001</u> <b>ON</b> : Warning is given by the flashing STOP lamp.</p> <p><b>Note:</b> Video and audio output may be disturbed when the reference video signal is not input, so it is recommended that a system which inputs the reference video signal be used.</p>

No./Item	Description
105 AUTO EE SEL	<p>This selects the memory card recorder mode in which the EE status is established when the MODE switch is set to EE.</p> <p><u>0000</u> <b>S/F/R</b> : EE status is established in STOP, FF and REW modes. However, EE status is established at all times when the card is ejected, regardless of the MODE switch setting.</p> <p><u>0001</u> <b>STOP</b> : EE status is established in STOP mode. However, EE status is established at all times when the card is ejected, regardless of the MODE switch setting.</p> <p><u>0002</u> <b>BLACK</b> : EE status is established in STOP mode. However, when the card is ejected, if the MODE switch is set to; <b>EE</b>: EE status is established. <b>PB</b>: The picture becomes black and the sound is muted.</p> <p><u>0003</u> <b>BLACK1</b> : EE status is established in STOP, FF and REW modes. However, when the card is ejected, if the MODE switch is set to; <b>EE</b>: EE status is established. <b>PB</b>: The picture becomes black and the sound is muted.</p> <p><u>0004</u> <b>GRAY</b> : EE status is established in STOP mode. However, when the card is ejected, if the MODE switch is set to; <b>EE</b>: EE status is established. <b>PB</b>: The picture becomes gray and the sound is muted.</p> <p><u>0005</u> <b>GRAY1</b> : EE status is established in STOP, FF and REW modes. However, when the card is ejected, if the MODE switch is set to; <b>EE</b>: EE status is established. <b>PB</b>: The picture becomes gray and the sound is muted.</p>

The underlined items indicates the initial setting.

## Setup menus (continued)

### ■ USER menu <OPERATION>

No./Item	Description
106 EE MODE SEL	<p>This selects the EE mode output signals.</p> <p><u>0000</u> <b>NORMAL</b> : Signals are output with a delay equivalent to the length of internal signal processing.</p> <p>0001 <b>THRU</b> : Signals are output directly, without internal processing, and so are output with no delay.</p> <p><b>Note:</b> When 1394 has been selected for the video input signals or when INT SG has been selected for video or audio, internal operations are forcibly set to NORMAL.</p>
107 PLAY DELAY	<p>This set the play delay time in frame increments.</p> <p><u>0000</u>    <u>0</u> :        : 0015    15</p>
112 V IN SEL INH	<p>This selects whether video input switching using the INPUT SELECT button is to be enabled or disabled.</p> <p>0000 <b>OFF</b> : Video input switching using the INPUT SELECT button is enabled.</p> <p>0001 <b>ON</b> : Video input switching using the INPUT SELECT button is disabled.</p> <p>0002 <b>REC</b> : Video input switching using the INPUT SELECT button after the memory card recorder has been transferred to a recording mode is disabled.</p>

No./Item	Description
113 A IN SEL INH	<p>This selects whether audio input switching using the INPUT SELECT button is to be enabled or disabled.</p> <p>0000 <b>OFF</b> : Audio input switching using the INPUT SELECT button is enabled.</p> <p>0001 <b>ON</b> : Audio input switching using the INPUT SELECT button is disabled.</p> <p>0002 <b>REC</b> : Audio input switching using the INPUT SELECT button after the memory card recorder has been transferred to a recording mode is disabled.</p> <p><b>Note:</b> Even when the ON or REC setting is selected to disable audio input switching using the INPUT SELECT button, it is still possible to set the setup menu items No. 715 (CH1 IN SEL), No. 716 (CH2 IN SEL), No. 717 (CH3 IN SEL), No. 718 (CH4 IN SEL), No. 719 (D IN SEL12) and No. 720 (D IN SEL34).</p>

The underlined items indicates the initial setting.

## Setup menus (continued)

### ■ USER menu <INTERFACE>

No./Item	Description
201 9P SEL	<p>This selects whether the REMOTE (9P) connector functions when the REMOTE button is lit.</p> <p><b>0000 OFF :</b> Connector does not function. <b>0001 ON :</b> Connector functions.</p>
202 ID SEL	<p>This sets the ID information to be returned to the controller.</p> <p><b>0000 OTHER</b> <b>0001 <u>DVCPRO</u></b> <b>0002 ORIG</b></p> <p>Notes: •ID information of any VTR except for the DVCPRO's is set in OTHER. •Select ORIG only when the unit has been connected to the specified controller.</p>
204 RS232C SEL	<p>This selects whether the RS-232C connector functions when the REMOTE button is lit.</p> <p><b>0000 <u>OFF</u> :</b> Connector does not function. <b>0001 ON :</b> Connector functions.</p>
205 BAUD RATE	<p>These settings are for selecting the RS-232C communication speed (baud rate). (Unit: Bps)</p> <p><b>0000 300</b> <b>0001 600</b> <b>0002 1200</b> <b>0003 2400</b> <b>0004 4800</b> <b>0005 <u>9600</u></b></p>
206 DATA LENGTH	<p>These settings are for selecting the RS-232C data length. (Unit: bit)</p> <p><b>0000 7</b> <b>0001 <u>8</u></b></p>
207 STOP BIT	<p>These settings are for selecting the RS-232C stop bit length. (Unit: bit)</p> <p><b>0000 1</b> <b>0001 <u>2</u></b></p>

No./Item	Description
208 PARITY	<p>These settings are for selecting the none, odd or even for the RS-232C parity bit.</p> <p><b>0000 <u>NON</u> :</b> Parity bit is not used. <b>0001 ODD:</b> An odd number of bits is used for the parity system. <b>0002 EVEN:</b> An even number of bits is used for the parity system.</p>
209 RETURN ACK	<p>These settings are for selecting whether the ACK code is to be returned when a command is received from RS-232C.</p> <p><b>0000 OFF :</b> ACK code is not returned. <b>0001 <u>ON</u> :</b> ACK code is returned.</p>

The underlined items indicates the initial setting.

## Setup menus (continued)

### ■ USER menu <EDIT>

No./Item	Description
303 STD/NON-STD	<p>This selects <b>STD</b> or <b>NON-STD</b> in accordance with the composite input signal.</p> <p><u>0000</u> <b>AUTO</b> : Standard/non-standard signals are automatically identified and processed.</p> <p>0001 <b>STD</b> : Standard signals are processed. (Forced STD)</p> <p>0002 <b>N-STD</b> : Non-standard signals are processed. (Forced NON-STD)</p> <p><b>Notes:</b></p> <ul style="list-style-type: none"> <li>•Use the non-standard (NON-STD) setting when video or audio trouble occurs with signals from laser discs or a satellite.</li> <li>•At the NON-STD setting, the images shown on the front panel's LCD monitor will be significantly disrupted when the unit's operation is transferred from the play mode to EE mode: this is normal and not indicative of malfunctioning.</li> </ul>
304 REF LOCK	<p>This selects the <b>REF LOCK</b> mode.</p> <p><u>0000</u> <b>AUTO</b> : Servo is synchronized with the input signal during recording, or with the REF signal during playback.</p> <p>0001 <b>EXT</b> : Servo is synchronized at all times with the REF signal.</p> <p>0002 <b>AUTO1</b> : Servo is synchronized with the input signal during recording, or with the REF signal during playback. When there is no reference (REF) signal, the EE output is synchronized with the internal reference signal at the AUTO setting or with the STD input signal at the AUTO1 setting. The AUTO1 setting is selected when the STD signal is to be used.</p> <p><b>Note:</b> At the AUTO setting, the images shown on the front panel's LCD monitor will be significantly disrupted when the unit's operation is transferred from the play mode to EE mode: this is normal and not indicative of malfunctioning.</p>

No./Item	Description
315 AFTER CUE-UP	<p>This selects the mode after cue-up operation is complete.</p> <p><u>0000</u> <b>STOP</b> : STOP mode 0001 <b>STILL</b> : SHTL STILL mode</p>
320 VAR FWD MAX	<p>This sets the maximum <b>SLOW FWD</b> speed.</p> <p><u>0000</u> <b>+4</b> : +4x speed 0001 <b>+2</b> : +2x speed 0002 <b>+1</b> : +1x speed</p> <p><b>Note:</b> At any speed setting other than 0 (+4), the phase cannot be synchronized from the editing controller.</p>
321 VAR REV MAX	<p>This sets the maximum <b>SLOW REV</b> speed.</p> <p><u>0000</u> <b>-4</b> : -4x speed 0001 <b>-2</b> : -2x speed 0002 <b>-1</b> : -1x speed</p>
323 JOG FWD MAX	<p>This sets the maximum <b>JOG FWD</b> speed.</p> <p><u>0000</u> <b>+4</b> : +4x speed 0001 <b>+2</b> : +2x speed <u>0002</u> <b>+1</b> : +1x speed</p> <p><b>Notes:</b></p> <ul style="list-style-type: none"> <li>•The maximum speed is set to +1 x when the dial on the front panel is operated.</li> <li>•At any speed setting other than 0 (+4), the phase cannot be synchronized from an editing controller which synchronizes the phase using the JOG command.</li> </ul>
324 JOG REV MAX	<p>This sets the maximum <b>JOG REV</b> speed.</p> <p><u>0000</u> <b>-4</b> : -4x speed 0001 <b>-2</b> : -2x speed <u>0002</u> <b>-1</b> : -1x speed</p> <p><b>Note:</b> The maximum speed is set to -1 x when the dial on the front panel is operated.</p>

The underlined items indicates the initial setting.

# Setup menus (continued)

## ■ USER menu <TIME CODE>

No./Item	Description												
500 VITC BLANK	<p>This selects whether to output the VITC signal at the positions selected by setup menu items No. 501 (VITC POS-1) and No. 502 (VITC POS-2).</p> <p><b>0000 BLANK :</b> VITC signals are not output.</p> <p><b>0001 THRU :</b> VITC signals are output.</p>												
501 VITC POS-1	<p>This sets the position where the VITC signal is to be inserted.</p> <table style="width: 100%; border: none;"> <tr> <td style="text-align: center;">[525i system]</td> <td style="text-align: center;">[625i system]</td> </tr> <tr> <td style="text-align: center;"><b>0000 10L</b></td> <td style="text-align: center;"><b>0000 7L</b></td> </tr> <tr> <td style="text-align: center;">:</td> <td style="text-align: center;">:</td> </tr> <tr> <td style="text-align: center;"><b>0006 16L</b></td> <td style="text-align: center;"><b>0004 11L</b></td> </tr> <tr> <td style="text-align: center;">:</td> <td style="text-align: center;">:</td> </tr> <tr> <td style="text-align: center;"><b>0010 20L</b></td> <td style="text-align: center;"><b>0015 22L</b></td> </tr> </table> <p><b>Note:</b> The same line as the one used for the setup menu items No. 502 (VITC POS-2) and No. 662 (UMID POS) setting cannot be set.</p>	[525i system]	[625i system]	<b>0000 10L</b>	<b>0000 7L</b>	:	:	<b>0006 16L</b>	<b>0004 11L</b>	:	:	<b>0010 20L</b>	<b>0015 22L</b>
[525i system]	[625i system]												
<b>0000 10L</b>	<b>0000 7L</b>												
:	:												
<b>0006 16L</b>	<b>0004 11L</b>												
:	:												
<b>0010 20L</b>	<b>0015 22L</b>												
502 VITC POS-2	<p>This sets the position where the VITC signal is to be inserted.</p> <table style="width: 100%; border: none;"> <tr> <td style="text-align: center;">[525i system]</td> <td style="text-align: center;">[625i system]</td> </tr> <tr> <td style="text-align: center;"><b>0000 10L</b></td> <td style="text-align: center;"><b>0000 7L</b></td> </tr> <tr> <td style="text-align: center;">:</td> <td style="text-align: center;">:</td> </tr> <tr> <td style="text-align: center;"><b>0008 18L</b></td> <td style="text-align: center;"><b>0006 13L</b></td> </tr> <tr> <td style="text-align: center;">:</td> <td style="text-align: center;">:</td> </tr> <tr> <td style="text-align: center;"><b>0010 20L</b></td> <td style="text-align: center;"><b>0015 22L</b></td> </tr> </table> <p><b>Note:</b> The same line as the one used for the setup menu items No. 501 (VITC POS-1) and No. 662(UMID POS) setting cannot be set.</p>	[525i system]	[625i system]	<b>0000 10L</b>	<b>0000 7L</b>	:	:	<b>0008 18L</b>	<b>0006 13L</b>	:	:	<b>0010 20L</b>	<b>0015 22L</b>
[525i system]	[625i system]												
<b>0000 10L</b>	<b>0000 7L</b>												
:	:												
<b>0008 18L</b>	<b>0006 13L</b>												
:	:												
<b>0010 20L</b>	<b>0015 22L</b>												
503 TCG REGEN	<p>This selects the signal to be regenerated when the time code generator (TCG) in the REGEN mode.</p> <p><b>0000 TC&amp;UB :</b> Both the time code and user bit are regenerated.</p> <p><b>0001 TC :</b> Only the time code is regenerated.</p> <p><b>0002 UB :</b> Only the user bit is regenerated.</p>												

The underlined items indicates the initial setting.

No./Item	Description
505 EXT TC SEL	<p>This selects the time code to be used when an external time code is to be used.</p> <p><b>0000 LTC :</b> The LTC of the TIME CODE IN connector is used.</p> <p><b>0001 VITC :</b> The VITC of the input video signal is used.</p> <p><b>Note:</b> During recording, there is a discrepancy in the picture and superimposed TC value displayed, but the actual recording is not adversely affected in any way.</p>
506 BINARY GP	<p>This sets the usage status of the user bit of the time code generated by the TCG.</p> <p><b>0000 000 :</b> NOT SPECIFIED (character set not specified)</p> <p><b>0001 001 :</b> ISO CHARACTER (8 bits character set based on ISO646, ISO2022)</p> <p><b>0002 010 :</b> UNASSIGNED 1 (undefined)</p> <p><b>0003 011 :</b> UNASSIGNED 2 (undefined)</p> <p><b>0004 100 :</b> UNASSIGNED 3 (undefined)</p> <p><b>0005 101 :</b> PAGE/LINE</p> <p><b>0006 110 :</b> UNASSIGNED 4 (undefined)</p> <p><b>0007 111 :</b> UNASSIGNED 5 (undefined)</p>
507 PHASE CORR	<p>This selects whether to control the phase correction of the LTC which is output from the TIME CODE OUT connector.</p> <p><b>0000 OFF :</b> Phase correction control is not performed.</p> <p><b>0001 ON :</b> Phase correction control is performed.</p>
508 TCG CF FLAG	<p>This selects whether the CF flag of the TCG is to ON.</p> <p><b>0000 OFF :</b> CF flag is OFF.</p> <p><b>0001 ON :</b> CF flag is ON.</p>
509 DF MODE	<p>This selects the DF or NDF mode for CTL and TCG.</p> <p><b>0000 DF :</b> The drop frame mode is used.</p> <p><b>0001 NDF :</b> The non-drop frame mode is used.</p> <p><b>Notes:</b></p> <ul style="list-style-type: none"> <li>• Drop frame mode is valid only when the REMOTE button is lit or the setup menu No. 001 (LOCAL ENA) is set to ENA.</li> <li>• This menu option is not displayed in the 625i system.</li> </ul>

## Setup menus (continued)

### ■ USER menu <TIME CODE>

No./Item	Description
510 TC OUT REF	<p>This is used to switch the phase of the time code, which is output from the TIME CODE OUT connector, for the external LTC input when the TCG switch is at the "EXT" position.</p> <p><u>0000</u> <b>V OUT</b> : Time code is synchronized with output video signal.</p> <p><b>0001</b> <b>TC_IN</b> : Time code is synchronized with external time code input.</p>
511 VITC OUT	<p>This selects how the VITC which is to be superimposed onto the output video signal during playback is to be output.</p> <p><u>0000</u> <b>SBC</b> : The time code recorded in the sub code area is output as the VITC.</p> <p><b>0001</b> <b>VAUX</b> : The time code recorded in the VAUX area is output as the VITC.</p>
514 VITC GEN	<p>This selects whether or not to record the internal time code generator value in the VAUX area.</p> <p><u>0000</u> <b>OFF</b> : The internal time code generator value is not recorded in the VAUX area. When video signals on which the time code has been recorded are input, the time code of the input signals is recorded in the VAUX area.</p> <p><b>0001</b> <b>ON</b> : The internal time code generator value is recorded in the VAUX area.</p> <p><b>Note:</b> If 1394 has been selected as the input signals, the time code on the input compressed signals will be recorded regardless of this menu's setting.</p>

#### Sub code area:

This area is separate from the video and audio data area on the P2 card. The time code complying with SMPTE/EBU standards is stored here.

#### VAUX area:

This area is to be found in the video data area on the P2 card. The additional information relating to the video data is stored here.

### ■ USER menu <VIDEO>

No./Item	Description
600 INT SG	<p>This selects the internal signal.</p> <p><b>0001</b> <b>BB</b> : The black burst is generated.</p> <p><b>0002</b> <b>CB100</b> : 100% color bars are generated.</p> <p><u><b>0003</b></u> <b>CB75</b> : 75% color bars are generated.</p>
601 OUT VSYNC	<p>This selects whether to float the vertical sync position of the video output in order to align the video output phase with the input in the EE/record/edit modes.</p> <p><u><b>0000</b></u> <b>N-VF</b> : Signals are not floated.</p> <p><b>0001</b> <b>VF</b> : Signals are floated.</p>
603 CC (F1) BLANK	<p>This selects ON or OFF for the closed caption signal of the first field.</p> <p><b>0000</b> <b>BLANK</b> : Signal is forcibly blanked.</p> <p><u><b>0001</b></u> <b>THRU</b> : Signal is not blanked.</p> <p><b>Note:</b> This menu option is not displayed in the 625i system.</p>
604 CC (F2) BLANK	<p>This selects ON or OFF for the closed caption signal of the second field.</p> <p><b>0000</b> <b>BLANK</b> : Signal is forcibly blanked.</p> <p><u><b>0001</b></u> <b>THRU</b> : Signal is not blanked.</p> <p><b>Note:</b> This menu option is not displayed in the 625i system.</p>
605 FREEZE SEL	<p>This selects the freeze mode for still pictures.</p> <p><u><b>0000</b></u> <b>FIELD</b> : Field freeze.</p> <p><b>0001</b> <b>FRAME</b> : Frame freeze.</p> <p><b>Notes:</b></p> <ul style="list-style-type: none"> <li>•When frame freeze has been selected, the frame slow status is established with the slow setting.</li> <li>•This setting is also followed when there is a freeze command from the RS-422A connector, but the picture displayed on the LCD monitor screen shown at this time will not be frozen.</li> </ul>
606 OUT C KILL	<p>This selects chroma color killer processing for the video output signals.</p> <p><b>0000</b> <b>B/W</b> : No color signals are output.</p> <p><u><b>0001</b></u> <b>COLOR</b> : Color signals are output.</p>

The underlined items indicates the initial setting.

## Setup menus (continued)

### ■ USER menu <VIDEO>

No./Item	Description
609 EDH	<p>This selects whether to superimpose EDH onto the SDI output signals.</p> <p><b>0000 OFF</b> : EDH is not superimposed.  <b>0001 ON</b> : EDH is superimposed.</p> <p><b>Note:</b>            Even when ON is selected for this setting, EDH is not superimposed onto the signals output from the SDI OUT 3 connector (optional) if the SUPER switch on the front panel is set to ON.</p>
610 P <sub>B</sub> /P <sub>R</sub> IN LV	<p>This selects the analog component input level.</p> <p><b>0000 M II</b> : M II level  <b>0001 B-CAM</b> : β-CAM level</p> <p><b>Note:</b>            This menu option is not displayed in the 625i system.</p>
611 YC SEP MODE	<p>This selects Y/C separation processing for the composite input signals.</p> <p><b>0000 B/W</b> :            The signals are processed as B/W signals.  <b>0001 AUTO</b> :            The signals are automatically detected.</p>
614 P <sub>B</sub> /P <sub>R</sub> OUT LV	<p>This selects the analog component output level.</p> <p><b>0000 M II</b> : M II level  <b>0001 B-CAM</b> : β-CAM level</p> <p><b>Note:</b>            This menu option is not displayed in the 625i system.</p>
618 INTERPOLATE	<p>This selects the interpolation operation.</p> <p>Vertical interpolation is conducted automatically during slow-motion playback to reduce the vertical movement of the playback pictures. However, this menu item enables the interpolation operation to be forcibly turned off.</p> <p><b>0000 OFF</b> :            Interpolation is forcibly turned off.  <b>0001 AUTO</b> :            Interpolation is automatically turned on during slow-motion playback.</p>

No./Item	Description
620 ESR MODE	<p>This selects the operation mode for edge subcarrier reduction (ESR) in the playback circuit.</p> <p><b>0000 OFF</b> :            The mode is forcibly set to OFF.  <b>0001 AUTO</b> :            The mode is automatically set to ON or OFF depending on the memory card recorder operation.</p>
621 CCR MODE	<p>This selects the cross color processing during playback.</p> <p><b>0000 OFF</b> :            The cross color is output with no changes made.  <b>0001 ON</b> :            The cross color can be reduced.</p> <p><b>Note:</b>            This menu option is not displayed in the 625i system.</p>
624 CC REC	<p>This selects whether to record the closed caption signals multiplexed on the input signals on the card.</p> <p><b>0000 OFF</b> :            No closed caption signal is recorded. In addition, the EE output signals are blanked.  <b>0001 ON</b> :            When a closed caption signal is detected from the selected input signal, it can be recorded on the card.</p> <p><b>Notes:</b></p> <ul style="list-style-type: none"> <li>• This menu option is not displayed in the 625i system.</li> <li>• If 1394 has been selected as the input signals, the closed caption signal on the input compressed signals will be recorded regardless of this menu's setting.</li> </ul>
645 WIDE SELECT	<p>This selects whether to record the WIDE information on the card.</p> <p><b>0001 WIDE</b> :            The information is recorded.  <b>0002 NORMAL</b> :            No information is recorded.</p> <p><b>Note:</b>            If 1394 has been selected as the input signals, the input information will be recorded.</p>

The underlined items indicates the initial setting.

## Setup menus (continued)

### ■ USER menu <VIDEO>

No./Item	Description
622 <b>SETUP 25</b> (For AJ-SPD850P)	<p>For setting 7.5% setup processing to be performed on input and output signals in the DVCPRO (25 Mbps) mode.</p> <p>When the STOP button is pressed, operation is transferred to the sub-screen, and the setup level is set for each output. To return from the sub-screen, press the STOP button again.</p> <p><b>Note:</b> This setup menu is not displayed in the 625i system.</p>
<b>Sub-screen</b>	
00 <b>CMPST IN</b>	<p>This selects the 7.5% setup processing for the input composite signal.</p> <p><b>0000 THRU :</b> The signal is recorded in its original form.</p> <p><b>0001 CUT :</b> The signal is recorded with the 7.5% setup removed.</p>
01 <b>CMPST OUT</b>	<p>This selects the 7.5% setup processing for the output composite signal.</p> <p><b>0000 THRU :</b> The signal is output in its original form.</p> <p><b>0001 ADD :</b> The signal is output with the 7.5% setup added.</p> <p><b>Note:</b> Bear in mind the setting for sub-screen item No. 03 (CMPNT OUT) of setup menu item No. 622 (SETUP 25).</p>
02 <b>CMPNT IN</b>	<p>This selects the 7.5% setup processing for the input component signal.</p> <p><b>0000 THRU :</b> The signal is recorded in its original form.</p> <p><b>0001 CUT :</b> The signal is recorded with the 7.5% setup removed.</p>
03 <b>CMPNT OUT</b>	<p>This selects the 7.5% setup processing for the output composite, component and serial (digital) signal.</p> <p><b>0000 THRU :</b> The signal is output in its original form.</p> <p><b>0001 CUT :</b> The signal is output with the 7.5% setup removed.</p> <p><b>0002 ADD :</b> The signal is output with the 7.5% setup added.</p>

No./Item	Description
623 <b>SETUP 50</b> (For AJ-SPD850P)	<p>For setting 7.5% setup processing to be performed on input and output signals in the DVCPRO50 (50 Mbps) mode.</p> <p>When the STOP button is pressed, operation is transferred to the sub-screen, and the setup level is set for each output. To return from the sub-screen, press the STOP button again.</p> <p><b>Note:</b> This setup menu is not displayed in the 625i system.</p>
<b>Sub-screen</b>	
00 <b>CMPST IN</b>	<p>This selects the 7.5% setup processing for the input composite signal.</p> <p><b>0000 THRU :</b> The signal is recorded in its original form.</p> <p><b>0001 CUT :</b> The signal is recorded with the 7.5% setup removed.</p>
01 <b>CMPST OUT</b>	<p>This selects the 7.5% setup processing for the output composite signal.</p> <p><b>0000 THRU :</b> The signal is output in its original form.</p> <p><b>0001 ADD :</b> The signal is output with the 7.5% setup added.</p> <p><b>Note:</b> Bear in mind the setting for sub-screen item No. 03 (CMPNT OUT) of setup menu item No. 623 (SETUP 50).</p>
02 <b>CMPNT IN</b>	<p>This selects the 7.5% setup processing for the input component signal.</p> <p><b>0000 THRU :</b> The signal is recorded in its original form.</p> <p><b>0001 CUT :</b> The signal is recorded with the 7.5% setup removed.</p>
03 <b>CMPNT OUT</b>	<p>This selects the 7.5% setup processing for the output composite, component and serial (digital) signal.</p> <p><b>0000 THRU :</b> The signal is output in its original form.</p> <p><b>0001 CUT :</b> The signal is output with the 7.5% setup removed.</p> <p><b>0002 ADD :</b> The signal is output with the 7.5% setup added.</p>

The underlined items indicates the initial setting.

## Setup menus (continued)

### ■ USER menu <VIDEO>

No./Item	Description														
660 UMID REC	<p>This selects whether or not to record the UMID information on the card.</p> <p><b>0000 OFF :</b> UMID information is not recorded on the card. In addition, EE output signals are blanked.</p> <p><b><u>0001</u> ON :</b> UMID information is recorded on the card.</p> <p><b>Note:</b> If THRU has been selected as the setup menu item No. 106 (EE MODE SEL) setting, UMID information of the EE output signals will be blanked.</p>														
661 UMID GEN	<p>This selects the UMID information to be recorded on the card when ON has been selected as the setup menu item No. 660 (UMID REC) setting.</p> <p><b>0000 INT :</b> Newly created UMID information of this unit is always recorded.</p> <p><b><u>0001</u> EXT :</b> The UMID information of the input signals is recorded. Newly created UMID information of this unit is recorded if there is no UMID information on the input signals.</p>														
662 UMID POS	<p>This sets the line on which the UMID information is to be superimposed.</p> <table style="width: 100%; border-collapse: collapse;"> <thead> <tr> <th style="text-align: left;">[525i system]</th> <th style="text-align: left;">[625i system]</th> </tr> </thead> <tbody> <tr> <td><b>0000 BLANK</b></td> <td><b>0000 BLANK</b></td> </tr> <tr> <td><b>0001 12L</b></td> <td><b>0001 18L</b></td> </tr> <tr> <td style="text-align: center;">:</td> <td style="text-align: center;">:</td> </tr> <tr> <td><b><u>0006</u> 17L</b></td> <td><b><u>0010</u> 17L</b></td> </tr> <tr> <td style="text-align: center;">:</td> <td style="text-align: center;">:</td> </tr> <tr> <td><b>0008 19L</b></td> <td><b>0015 22L</b></td> </tr> </tbody> </table> <p><b>Note:</b> The line selected for the setup menu item No. 501 (VITC POS-1) and No. 502 (VITC POS-2) settings cannot be selected for this item.</p>	[525i system]	[625i system]	<b>0000 BLANK</b>	<b>0000 BLANK</b>	<b>0001 12L</b>	<b>0001 18L</b>	:	:	<b><u>0006</u> 17L</b>	<b><u>0010</u> 17L</b>	:	:	<b>0008 19L</b>	<b>0015 22L</b>
[525i system]	[625i system]														
<b>0000 BLANK</b>	<b>0000 BLANK</b>														
<b>0001 12L</b>	<b>0001 18L</b>														
:	:														
<b><u>0006</u> 17L</b>	<b><u>0010</u> 17L</b>														
:	:														
<b>0008 19L</b>	<b>0015 22L</b>														

### ■ USER menu <AUDIO>

No./Item	Description
701 CH1 IN LV	<p>This selects the audio input (CH1) reference level switching.</p> <p><b>0000 4dB</b> <b><u>0001</u> 0dB</b> <b>0002 -20dB</b></p>
702 CH2 IN LV	<p>This selects the audio input (CH2) reference level switching.</p> <p><b>0000 4dB</b> <b>0001 0dB</b> <b>0002 -20dB</b></p>
703 CH3 IN LV	<p>This selects the audio input (CH3) reference level switching.</p> <p><b>0000 4dB</b> <b><u>0001</u> 0dB</b> <b>0002 -20dB</b></p>
704 CH4 IN LV	<p>This selects the audio input (CH4) reference level switching.</p> <p><b>0000 4dB</b> <b><u>0001</u> 0dB</b> <b>0002 -20dB</b></p>
706 CH1 OUT LV	<p>This selects the audio output (CH1) reference level switching.</p> <p><b>0000 4dB</b> <b><u>0001</u> 0dB</b> <b>0002 -20dB</b></p>
707 CH2 OUT LV	<p>This selects the audio output (CH2) reference level switching.</p> <p><b>0000 4dB</b> <b><u>0001</u> 0dB</b> <b>0002 -20dB</b></p>
708 CH3 OUT LV	<p>This selects the audio output (CH3) reference level switching.</p> <p><b>0000 4dB</b> <b><u>0001</u> 0dB</b> <b>0002 -20dB</b></p>
709 CH4 OUT LV	<p>This selects the audio output (CH4) reference level switching.</p> <p><b>0000 4dB</b> <b><u>0001</u> 0dB</b> <b>0002 -20dB</b></p>

The underlined items indicates the initial setting.

## Setup menus (continued)

### ■ USER menu <AUDIO>

No./Item	Description
711 MONIL OUT LV	This selects the audio monitor output (Lch) reference level switching.  0000 4dB <u>0001 0dB</u> 0002 -20dB
712 MONIR OUT LV	This selects the audio monitor output (Rch) reference level switching.  0000 4dB <u>0001 0dB</u> 0002 -20dB
713 MONI OUT	This selects whether to link the volume level of the audio monitor output to the setting of the headphone volume control.  0000 UNITY : The sound is output at a fixed level regardless of the position of the volume control. <u>0001 VAR :</u> The volume level is linked to the setting of the volume control.
715 CH1 IN SEL	This selects the CH1 input when USER SET has been selected by pressing the memory card recorder's AUDIO INPUT SELECT button.  0000 ANA : Analog input. 0001 DIGI : Digital input.
716 CH2 IN SEL	This selects the CH2 input when USER SET has been selected by pressing the memory card recorder's AUDIO INPUT SELECT button.  0000 ANA : Analog input. 0001 DIGI : Digital input.
717 CH3 IN SEL	This selects the CH3 input when USER SET has been selected by pressing the memory card recorder's AUDIO INPUT SELECT button.  0000 ANA : Analog input. 0001 DIGI : Digital input.
718 CH4 IN SEL	This selects the CH4 input when USER SET has been selected by pressing the memory card recorder's AUDIO INPUT SELECT button.  0000 ANA : Analog input. 0001 DIGI : Digital input.

No./Item	Description
719 D IN SEL12	This selects the CH1 and CH2 digital input when USER SET has been selected by pressing the memory card recorder's AUDIO INPUT SELECT button.  0000 AES : AES input 0001 SIF : SDI input
720 D IN SEL34	This selects the CH3 and CH4 digital input when USER SET has been selected by pressing the memory card recorder's AUDIO INPUT SELECT button.  0000 AES : AES input 0001 SIF : SDI input
727 PB FADE	This selects the processing method for the audio edit points (IN point, OUT point) during playback etc.  0000 AUTO : The processing method accords with the status established during recording. 0001 CUT : Forced CUT 0002 FADE : Forced FADE
728 EMBEDDED AUD	This selects whether to superimpose the audio data onto the SDI output.  0000 OFF : Data is not superimposed. 0001 ON : Data is superimposed.
734 MONI SEL INH	This selects whether the operation of the MONITOR SELECT button on the front panel is to be enabled or disabled.  0000 OFF : Operation is enabled. 0001 ON : Operation is disabled. 0002 ON1 : Operation is disabled in the FULL display mode and enabled only in the FINE display mode.
754 AMIX SEL INH	This selects the input audio channel switching mode using the REC CH1/CH3 and REC CH2/CH4 buttons.  0000 OFF : The audio input channels can be switched using the REC CH buttons. 0001 ON : Switching of the audio input channels using the REC CH buttons is prohibited. 0002 REC : After the unit's operation has been transferred to recording, switching of the audio input channels using the REC CH buttons is prohibited.

The underlined items indicates the initial setting.

# Setup menus (continued)

## ■ USER menu <V BLANK>

No./Item	Description
755 25M REC CH	<p>Used to select the number of AUDIO channels for DVCPRO (25 Mbps) or DV (25 Mbps) recording.</p> <p><b>0000 2CH:</b> Records on two channels.</p> <p><b>0001 4CH:</b> Records on four channels.</p> <p><b>Note:</b> Four-channel recording is always used with DVCPRO50 (50 Mbps).</p>
800 ADD LINE 25	<p>This selects the mode for recording signals on additional lines.</p> <p><b>0000 OFF:</b> No signals are recorded on additional lines.</p> <p><b>0001 YC422:</b> The 422 mode signals are recorded on 1 line.</p> <p><b>0002 YC411:</b> The 411 mode signals are recorded on 1 line.</p> <p><b>0003 Y1_B/W:</b> Only the Y signal is recorded on 1 line directly.</p> <p><b>0004 Y1_BPF:</b> Only the Y signal is recorded on 1 line after it has been separated from the C signal.</p> <p><b>0005 C1:</b> Only the C signal is recorded on 1 line.</p> <p><b>0006 Y2_B/W:</b> Only the Y signal is recorded on 2 lines directly.</p> <p><b>0007 Y2_BPF:</b> Only the Y signal is recorded on 2 lines after it has been separated from the C signal.</p> <p><b>0008 C2:</b> Only the C signal is recorded on 2 lines.</p> <p><b>Notes:</b></p> <ul style="list-style-type: none"> <li>•When a setting from "0001 (YC422)" to "0008 (C2)" is selected and the STOP button is pressed, operation transfers to the sub-screen, and the recording line or lines can be selected. To return from the sub-screen, press the STOP button again.</li> <li>•The setting takes effect when the system format is 25 Mbps.</li> </ul>

No./Item	Description																						
Sub-screen																							
00 REC LINE1	<p>This selects the additional line where the signals are to be recorded.</p> <table> <tr> <td>[525i system]</td> <td>[625i system]</td> </tr> <tr> <td><b>0000 10L</b></td> <td><b>0000 7L</b></td> </tr> <tr> <td>: :</td> <td>: :</td> </tr> <tr> <td><b>0002 12L</b></td> <td><b>0002 9L</b></td> </tr> <tr> <td>: :</td> <td>: :</td> </tr> <tr> <td><b>0012 22L</b></td> <td><b>0015 22L</b></td> </tr> <tr> <td><b>0013 263L</b></td> <td><b>0016 320L</b></td> </tr> <tr> <td><b>0014 273L</b></td> <td>: :</td> </tr> <tr> <td>: :</td> <td><b>0031 335L</b></td> </tr> <tr> <td><b>0025 284L</b></td> <td><b>0032 623L</b></td> </tr> <tr> <td><b>0026 525L</b></td> <td></td> </tr> </table>	[525i system]	[625i system]	<b>0000 10L</b>	<b>0000 7L</b>	: :	: :	<b>0002 12L</b>	<b>0002 9L</b>	: :	: :	<b>0012 22L</b>	<b>0015 22L</b>	<b>0013 263L</b>	<b>0016 320L</b>	<b>0014 273L</b>	: :	: :	<b>0031 335L</b>	<b>0025 284L</b>	<b>0032 623L</b>	<b>0026 525L</b>	
[525i system]	[625i system]																						
<b>0000 10L</b>	<b>0000 7L</b>																						
: :	: :																						
<b>0002 12L</b>	<b>0002 9L</b>																						
: :	: :																						
<b>0012 22L</b>	<b>0015 22L</b>																						
<b>0013 263L</b>	<b>0016 320L</b>																						
<b>0014 273L</b>	: :																						
: :	<b>0031 335L</b>																						
<b>0025 284L</b>	<b>0032 623L</b>																						
<b>0026 525L</b>																							
01 REC LINE2	<p>This selects the additional line where the signals are to be recorded.</p> <table> <tr> <td>[525i system]</td> <td>[625i system]</td> </tr> <tr> <td><b>0000 10L</b></td> <td><b>0000 7L</b></td> </tr> <tr> <td>: :</td> <td>: :</td> </tr> <tr> <td><b>0012 22L</b></td> <td><b>0015 22L</b></td> </tr> <tr> <td><b>0013 263L</b></td> <td><b>0016 320L</b></td> </tr> <tr> <td><b>0014 273L</b></td> <td>: :</td> </tr> <tr> <td>: :</td> <td><b>0018 322L</b></td> </tr> <tr> <td><b>0016 275L</b></td> <td>: :</td> </tr> <tr> <td>: :</td> <td><b>0031 335L</b></td> </tr> <tr> <td><b>0025 284L</b></td> <td><b>0032 623L</b></td> </tr> <tr> <td><b>0026 525L</b></td> <td></td> </tr> </table> <p><b>Note:</b> This menu option is not displayed when additional line mode setting "1" through "5" has been selected.</p>	[525i system]	[625i system]	<b>0000 10L</b>	<b>0000 7L</b>	: :	: :	<b>0012 22L</b>	<b>0015 22L</b>	<b>0013 263L</b>	<b>0016 320L</b>	<b>0014 273L</b>	: :	: :	<b>0018 322L</b>	<b>0016 275L</b>	: :	: :	<b>0031 335L</b>	<b>0025 284L</b>	<b>0032 623L</b>	<b>0026 525L</b>	
[525i system]	[625i system]																						
<b>0000 10L</b>	<b>0000 7L</b>																						
: :	: :																						
<b>0012 22L</b>	<b>0015 22L</b>																						
<b>0013 263L</b>	<b>0016 320L</b>																						
<b>0014 273L</b>	: :																						
: :	<b>0018 322L</b>																						
<b>0016 275L</b>	: :																						
: :	<b>0031 335L</b>																						
<b>0025 284L</b>	<b>0032 623L</b>																						
<b>0026 525L</b>																							

The underlined items indicates the initial setting.

# Setup menus (continued)

## ■ USER menu <V BLANK>

No./Item	Description																						
801 ADD LINE 50	<p>This selects the mode for recording signals on additional lines.</p> <p><b>0000 OFF :</b> No signals are recorded on additional lines.</p> <p><b>0001 YC422 :</b> The 422 mode signals are recorded on 2 lines.</p> <p><b>0002 Y4_B/W :</b> Only the Y signal is recorded on 4 lines directly.</p> <p><b>0003 Y4_BPF :</b> Only the Y signal is recorded on 4 lines after it has been separated from the C signal.</p> <p><b>0004 C4 :</b> Only the C signal is recorded on 4 lines.</p> <p><b>Notes:</b></p> <ul style="list-style-type: none"> <li>•When a setting from “0001 (YC422)” to “0004 (C4)” is selected and the STOP button is pressed, operation transfers to the sub-screen, and the recording lines can be selected.</li> <li>To return from the sub-screen, press the STOP button again.</li> <li>•The setting takes effect when the system format is 50 Mbps.</li> </ul>																						
<b>Sub-screen</b>																							
00 REC LINE1	<p>This selects the additional line where the signals are to be recorded.</p> <table> <tr> <td>[525i system]</td> <td>[625i system]</td> </tr> <tr> <td><b>0000 10L</b></td> <td><b>0000 7L</b></td> </tr> <tr> <td>: :</td> <td>: :</td> </tr> <tr> <td><b>0002 12L</b></td> <td><b>0002 9L</b></td> </tr> <tr> <td>: :</td> <td>: :</td> </tr> <tr> <td><b>0012 22L</b></td> <td><b>0015 22L</b></td> </tr> <tr> <td><b>0013 263L</b></td> <td><b>0016 320L</b></td> </tr> <tr> <td><b>0014 273L</b></td> <td>: :</td> </tr> <tr> <td>: :</td> <td><b>0031 335L</b></td> </tr> <tr> <td><b>0025 284L</b></td> <td><b>0032 623L</b></td> </tr> <tr> <td><b>0026 525L</b></td> <td></td> </tr> </table>	[525i system]	[625i system]	<b>0000 10L</b>	<b>0000 7L</b>	: :	: :	<b>0002 12L</b>	<b>0002 9L</b>	: :	: :	<b>0012 22L</b>	<b>0015 22L</b>	<b>0013 263L</b>	<b>0016 320L</b>	<b>0014 273L</b>	: :	: :	<b>0031 335L</b>	<b>0025 284L</b>	<b>0032 623L</b>	<b>0026 525L</b>	
[525i system]	[625i system]																						
<b>0000 10L</b>	<b>0000 7L</b>																						
: :	: :																						
<b>0002 12L</b>	<b>0002 9L</b>																						
: :	: :																						
<b>0012 22L</b>	<b>0015 22L</b>																						
<b>0013 263L</b>	<b>0016 320L</b>																						
<b>0014 273L</b>	: :																						
: :	<b>0031 335L</b>																						
<b>0025 284L</b>	<b>0032 623L</b>																						
<b>0026 525L</b>																							
01 REC LINE2	<p>This selects the additional line where the signals are to be recorded.</p> <table> <tr> <td>[525i system]</td> <td>[625i system]</td> </tr> <tr> <td><b>0000 10L</b></td> <td><b>0000 7L</b></td> </tr> <tr> <td>: :</td> <td>: :</td> </tr> <tr> <td><b>0012 22L</b></td> <td><b>0015 22L</b></td> </tr> <tr> <td><b>0013 263L</b></td> <td><b>0016 320L</b></td> </tr> <tr> <td><b>0014 273L</b></td> <td>: :</td> </tr> <tr> <td>: :</td> <td><b>0018 322L</b></td> </tr> <tr> <td><b>0016 275L</b></td> <td>: :</td> </tr> <tr> <td>: :</td> <td><b>0031 335L</b></td> </tr> <tr> <td><b>0025 284L</b></td> <td><b>0032 623L</b></td> </tr> <tr> <td><b>0026 525L</b></td> <td></td> </tr> </table>	[525i system]	[625i system]	<b>0000 10L</b>	<b>0000 7L</b>	: :	: :	<b>0012 22L</b>	<b>0015 22L</b>	<b>0013 263L</b>	<b>0016 320L</b>	<b>0014 273L</b>	: :	: :	<b>0018 322L</b>	<b>0016 275L</b>	: :	: :	<b>0031 335L</b>	<b>0025 284L</b>	<b>0032 623L</b>	<b>0026 525L</b>	
[525i system]	[625i system]																						
<b>0000 10L</b>	<b>0000 7L</b>																						
: :	: :																						
<b>0012 22L</b>	<b>0015 22L</b>																						
<b>0013 263L</b>	<b>0016 320L</b>																						
<b>0014 273L</b>	: :																						
: :	<b>0018 322L</b>																						
<b>0016 275L</b>	: :																						
: :	<b>0031 335L</b>																						
<b>0025 284L</b>	<b>0032 623L</b>																						
<b>0026 525L</b>																							

No./Item	Description																				
02 REC LINE3	<p>This selects the additional line where the signals are to be recorded.</p> <table> <tr> <td>[525i system]</td> <td>[625i system]</td> </tr> <tr> <td><b>0000 10L</b></td> <td><b>0000 7L</b></td> </tr> <tr> <td>: :</td> <td>: :</td> </tr> <tr> <td><b>0003 13L</b></td> <td><b>0003 10L</b></td> </tr> <tr> <td>: :</td> <td>: :</td> </tr> <tr> <td><b>0012 22L</b></td> <td><b>0015 22L</b></td> </tr> <tr> <td><b>0013 263L</b></td> <td><b>0016 320L</b></td> </tr> <tr> <td>: :</td> <td>: :</td> </tr> <tr> <td><b>0025 284L</b></td> <td><b>0032 623L</b></td> </tr> <tr> <td><b>0026 525L</b></td> <td></td> </tr> </table> <p><b>Note:</b> This menu option is not displayed when setting “1” has been selected as the additional line mode.</p>	[525i system]	[625i system]	<b>0000 10L</b>	<b>0000 7L</b>	: :	: :	<b>0003 13L</b>	<b>0003 10L</b>	: :	: :	<b>0012 22L</b>	<b>0015 22L</b>	<b>0013 263L</b>	<b>0016 320L</b>	: :	: :	<b>0025 284L</b>	<b>0032 623L</b>	<b>0026 525L</b>	
[525i system]	[625i system]																				
<b>0000 10L</b>	<b>0000 7L</b>																				
: :	: :																				
<b>0003 13L</b>	<b>0003 10L</b>																				
: :	: :																				
<b>0012 22L</b>	<b>0015 22L</b>																				
<b>0013 263L</b>	<b>0016 320L</b>																				
: :	: :																				
<b>0025 284L</b>	<b>0032 623L</b>																				
<b>0026 525L</b>																					
03 REC LINE4	<p>This selects the additional line where the signals are to be recorded.</p> <table> <tr> <td>[525i system]</td> <td>[625i system]</td> </tr> <tr> <td><b>0000 10L</b></td> <td><b>0000 7L</b></td> </tr> <tr> <td>: :</td> <td>: :</td> </tr> <tr> <td><b>0012 22L</b></td> <td><b>0015 22L</b></td> </tr> <tr> <td><b>0013 263L</b></td> <td>: :</td> </tr> <tr> <td>: :</td> <td><b>0019 323L</b></td> </tr> <tr> <td><b>0017 276L</b></td> <td>: :</td> </tr> <tr> <td>: :</td> <td><b>0031 335L</b></td> </tr> <tr> <td><b>0025 284L</b></td> <td><b>0032 623L</b></td> </tr> <tr> <td><b>0026 525L</b></td> <td></td> </tr> </table> <p><b>Note:</b> This menu option is not displayed when setting “1” has been selected as the additional line mode.</p>	[525i system]	[625i system]	<b>0000 10L</b>	<b>0000 7L</b>	: :	: :	<b>0012 22L</b>	<b>0015 22L</b>	<b>0013 263L</b>	: :	: :	<b>0019 323L</b>	<b>0017 276L</b>	: :	: :	<b>0031 335L</b>	<b>0025 284L</b>	<b>0032 623L</b>	<b>0026 525L</b>	
[525i system]	[625i system]																				
<b>0000 10L</b>	<b>0000 7L</b>																				
: :	: :																				
<b>0012 22L</b>	<b>0015 22L</b>																				
<b>0013 263L</b>	: :																				
: :	<b>0019 323L</b>																				
<b>0017 276L</b>	: :																				
: :	<b>0031 335L</b>																				
<b>0025 284L</b>	<b>0032 623L</b>																				
<b>0026 525L</b>																					
802 TELETEXT SEL (For AJ-SPD850P)	<p>This selects the type of teletext signals to be recorded.</p> <p><b>0000 MOJI :</b> MOJI system</p> <p><b>0001 NABTS :</b> NABTS system</p> <p><b>Notes:</b></p> <ul style="list-style-type: none"> <li>•This menu option is not displayed in the 625i system.</li> <li>•VITC signals are often mistakenly detected as teletext signals when the NABTS system has been selected. If this happens, select MANU as the setting for setup menu No. 803 (TELETEXT DET), then select the line for teletext signals.</li> </ul>																				

The underlined items indicates the initial setting.



## Setup menus (continued)

### ■ USER menu <V BLANK>

Number of lines which can be set for TELETEXT

•When 25 Mbps is the recording/playback format.

No. 800: ADD LINE 25 setting value	Number of lines which can be set			
	[525i system]		[625i system]	
	660: UMID REC setting value		660: UMID REC setting value	
	OFF	ON	OFF	ON
OFF	13	10	14	12
YC422	5	4	7	5
YC411	8	5	10	8
Y1_B/W	13	10	14	12
Y1_BPF				
C1				
Y2_B/W	5	4	7	5
Y2_BPF				
C2				

•When 50 Mbps is the recording/playback format.

No. 801: ADD LINE 50 setting value	Number of lines which can be set			
	[525i system]		[625i system]	
	660: UMID REC setting value		660: UMID REC setting value	
	OFF	ON	OFF	ON
OFF	10	9	15	12
YC422				
Y4_B/W				
Y4_BPF				
C4				

No./Item	Description
900  LCD PROTECT	<p>Sets LCD protect mode.</p> <p><b>0000 OFF</b> : LCD protect mode is off. <b>0001 ON</b> : LCD protect mode is on.</p> <p><b>Notes:</b></p> <ul style="list-style-type: none"> <li>•If no operations are performed on the front panel, or if the video is not updated for some length of time, LCD output is turned off after approximately five minutes.</li> <li>•To turn off LCD protect mode, operate a button or dial on the front panel, or start playback through the controller. Note that the operation performed to turn off LCD protect mode will be executed.</li> </ul>
901  BL BRIGHT	<p>This sets the brightness of the LCD's backlight.</p> <p><b>0000 NORMAL:</b> The backlight lights at the normal brightness level. <b>0001 HIGH:</b> The backlight lights brightly.</p>
902  GUI OUTPUT	<p>This sets whether to output the GUI screen display to the ANALOG COMPONENT VIDEO OUT, ANALOG COMPOSITE VIDEO OUT and SERIAL DIGITAL COMPONENT VIDEO OUT connectors.</p> <p><b>0000 OFF:</b> The screen display is not output. <b>0001 ON:</b> The screen display is output.</p>
903  P.ON GUI	<p>This sets whether to display the thumbnail screen when the power is turned on.</p> <p><b>0000 OFF:</b> The thumbnail screen is not displayed. <b>0001 THUMB:</b> The thumbnail screen is displayed.</p>

The underlined items indicates the initial setting.

## Setup menus (continued)

### ■ USER menu <MENU>

No./Item	Description
<b>A00</b> <b>LOAD</b>	<p>This selects the user file whose contents will be loaded into USER1.</p> <p><u>0000</u> <b>USER2</b> : The USER2 file contents are loaded.</p> <p><b>0001</b> <b>USER3</b> : The USER3 file contents are loaded.</p> <p><b>0002</b> <b>USER4</b> : The USER4 file contents are loaded.</p> <p><b>0003</b> <b>USER5</b> : The USER5 file contents are loaded.</p> <p><b>Note:</b> When the SET button is pressed after loading, the setting will be stored in the memory. When the MENU button is pressed, the setting will not be changed.</p>
<b>A01</b> <b>SAVE</b>	<p>This selects the user file into which the USER1 settings will be saved.</p> <p><u>0000</u> <b>USER2</b> : The settings are saved in USER2.</p> <p><b>0001</b> <b>USER3</b> : The settings are saved in USER3.</p> <p><b>0002</b> <b>USER4</b> : The settings are saved in USER4.</p> <p><b>0003</b> <b>USER5</b> : The settings are saved in USER5.</p> <p><b>0004</b> <b>LOCKED</b> : This display appears when all the user files are in the change prohibit status.</p> <p><b>Notes:</b></p> <ul style="list-style-type: none"> <li>•User files whose status have been set to change prohibit cannot be selected.</li> <li>•When all the user files are in the change prohibit status, the "LOCKED" display appears and the contents cannot be saved.</li> </ul>

No./Item	Description
<b>A02</b> <b>P. ON LOAD</b>	<p>This loads the contents of the selected user file into USER1 and it starts operation with the USER1 settings when the power is turned on.</p> <p><u>0000</u> <b>OFF</b> : Operation is started with the settings of the previously set user file.</p> <p><b>0001</b> <b>USER2</b> : The contents of USER2 are loaded into USER1 and operation is started with the USER1 settings.</p> <p><b>0002</b> <b>USER3</b> : The contents of USER3 are loaded into USER1 and operation is started with the USER1 settings.</p> <p><b>0003</b> <b>USER4</b> : The contents of USER4 are loaded into USER1 and operation is started with the USER1 settings.</p> <p><b>0004</b> <b>USER5</b> : The contents of USER5 are loaded into USER1 and operation is started with the USER1 settings.</p>
<b>A03</b> <b>MENU LOCK</b>	<p>This selects whether to set or release the user file (USER2-USER5) lock mode.</p> <p><u>0000</u> <b>OFF</b> : The lock is released (changes can be made).</p> <p><b>0001</b> <b>ON</b> : The lock is set (changes are prohibited).</p> <p><b>Note:</b> The lock cannot be set for USER1.</p>

#### Notes:

- No. A00 (LOAD), No. A01 (SAVE) and No. A02 (P. ON LOAD) are the menu items which can be set only for USER1. They are not displayed with the USER2-USER5 files.
- No. A03 (MENU LOCK) is the menu item which can be set only for the USER2-USER5 files. It is not displayed with USER1.

The underlined items indicates the initial setting.