

USE MODE SETTING

■ Use Mode Setting

The camera has four use modes, and various functions for four use modes have been preset.

Functions can be set as best suited to each use mode.

- Halogen mode
Suited to indoor shooting, such as at weddings, parties, lecture meetings, events, etc.
Settings can be changed using a simple menu.
- Fluorescent mode
Suited to indoor shooting under fluorescent lighting.
Settings can be changed using a simple menu.
- Outdoor mode
Suited to outdoor shooting.
Settings can be changed using a simple menu.
- User mode
Settings can be changed using a detail menu.

■ SETTING BY CAMERA

1. Turn the camera on while keeping the MENU switch depressed.
The use mode setting menu shown at right appears on the monitor screen and one of the use mode blinks.

2. Press the MENU switch, ITEM/AWC switch, or NO/BAR switch to let the desired use mode blink.
MENU switch (↑): The blinking item moves up by one.
ITEM/AWC switch (↓), NO/BAR switch (-): The blinking item moves down by one.

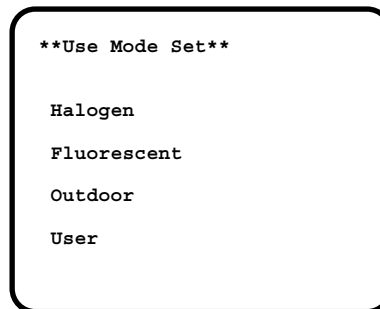

3. Press the YES/ABC Switch.
The blinking use mode comes into effect. After the use mode setting menu is shown for about 5 seconds, the camera returns to be ready for operation. Then, the camera operates in the selected use mode.

■ SETTING BY RCU (RCB) OR HYBRID CONTROL PANEL

An operation mode is selected depending on the position of the scene file switch.

Operation mode	Scene File Switch Position of RCU (RCB)	Scene File Switch Position of Hybrid control panel
Halogen Mode	1	1
Fluorescent Mode	2	2
Outdoor Mode	3	3
User's Mode	USER SET	4

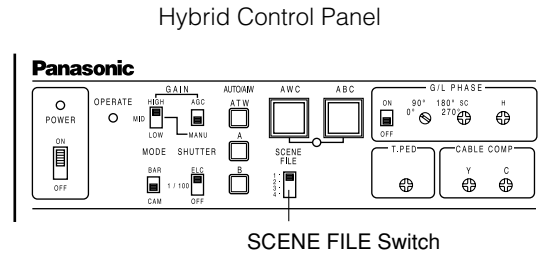
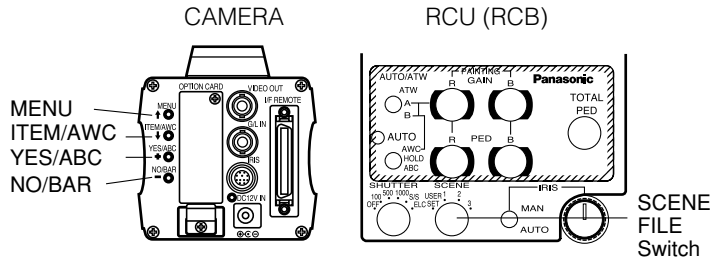

MENU ITEM SETTING

■ MENU ITEM SETTING

- Each of the four use modes of the camera has a main menu. (Shown at right)
- Each item of the main menu has a submenu, which consists of several settings.
- These settings have been preset to the optimum values to suit each use mode, and can be changed to suit actual shooting conditions.
- They can be set from the camera and RCU (RCB). They can also be set from the hybrid control panel using the switches, but the setting items are limited because the menu is not shown.

● MAIN MENU SCREEN

Main Menu of Halogen,
Fluorescent, Outdoor Mode

Main Menu of User Mode

```
**Halogen Mode Set**  
Brightness Set  
Color Set  
G/L, Color Bar Set  
Sharpness(DTL) Set  
Other Set  
(Option Card Set)  
  
Initialize Data  
  
(End)
```

```
**User Mode Set**  
Iris, Shutter, Gain Set  
Color Set  
G/L, Color Bar Set  
Detail Set1 Detail Set2  
Color Matrix Set  
Other Set1 Other Set2  
(Option Card Set)  
  
Initialize Data  
  
(End)
```

Blinking

Use Mode

Notes:

- Composite signals are output from the video output regardless of the position ENC/VF of the RCU (RCB) user set switch.
- [End] is displayed only in setting from the camera alone.
- [Option Card Set] is shown only when an optional card is inserted.

* When the color bar signal is output from camera, "G/L, Color Bar Set" is displayed.

```
**G/L Adjustment Set**  
H Phase (±0)  
SC Coarse ( 1)  
SC Fine (±0)  
Color Bar Set 7.5IRE  
  
Return
```

■ SETTING

1. From the camera alone:

Keep the MENU switch depressed for 5 seconds or more.

From RCU (RCB):

Set the user set switch in the pocket to the ON position.

The main menu appears on the monitor screen.

- Each time the MENU switch (↑), ITEM/AWC switch (↓), or NO/BAR switch (-) is pressed, the blinking item moves up or down.
- When the YES/ABC switch is pressed after selecting the desired item to blink, the submenu for the selected item appears on the screen.
- Select the desired item to be changed in its settings using the the MENU switch (↑) and ITEM/AWC switch (↓).
- Press the YES/ABC switch (+) or NO/BAR switch (-) to change the settings.
- Select [Return] using the MENU switch and ITEM/AWC switch, then press the YES/ABC switch to return to the main menu.
- After changing the settings, take the following steps.

Camera alone: Select [End] using the MENU switch and ITEM/AWC switch and press the YES/ABC switch.

RCU (RCB): Set the user set switch in the pocket to the OFF position.

The camera will now operate according to the new settings.

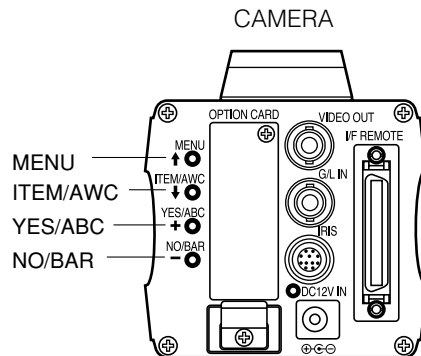

RCU (RCB)

USER SET SWITCH

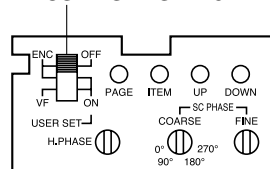

■ SUB MENU (Halogen Mode, Fluorescent Mode, Outdoor Mode)

① Brightness Set Display

```

**Brightness Set**
1---- Picture Level      ±0
2---- Light PEAK/AVG    0
3---- Light Area        Top Cut
4---- Auto ND(ELC)      (OFF)
5---- Auto Gain Up      (OFF)
6---- AGC Max Gain      (---)
7---- Manual Gain Up    (0dB)
8---- Digital Gain Up   0dB
9---- Charge Time       OFF
10--- Pedestal          (±0)
      Return
  
```

③ G/L Adjustment Set Display

```

**G/L Adjustment Set**
1---- H Phase           (±0)
2---- SC Coarse         ( 1)
3---- SC Fine           (±0)
4---- Color Bar Set     7.5IRE
      Return
  
```

⑤ Other Set Display

```

**Other Set**
1---- Contrast(Gamma)   Mid
2---- Shutter Speed     (OFF)
3---- Synchro Scan      ---
4---- V Resolution      Normal
5---- Baud Rate          9600bps
6---- Component         Y/Pr/Pb
7---- Digital Extender   OFF
8---- Fan                Auto
9---- Auto Focus         OFF
10--- Filter             Normal
      Return
  
```

② Color Set Display

```

**Color Set**
1---- Chroma Level      ±0
2---- Flesh Tone        ±0
3---- White Bal         (AWC A)
4---- ATW Speed         ---
5---- Nega/Posi         Posi
      Return
  
```

④ Sharpness (DTL) Set Display

```

**Sharpness (DTL) Set**
1---- DTL Select        Sharpness
2---- Level              (High)
3---- Noise Suppress    OFF
4---- Clean DNR         OFF
5---- 3D-DNR            OFF
6---- DTL Flesh Tone    Mid
      Return
  
```

- Settings enclosed in parentheses can be set with the RCU (RCB) switch or VR in RCU (RCB) mode.
- To return to the initial settings, refer to page 56.

■ Setting and Changing of the Setting (Halogen Mode, Fluorescent Mode, Outdoor Mode)

① Brightness Set Display

1. Video Level Adjustment [Picture Level: -50 to +50]

Convergence level of AUTO IRIS/AUTO GAIN UP/AUTO ND (ELC) can be adjusted.

2. Detecting Ratio Adjustment [Light PEAK/AVG: P50 to A50]

The ratio of AUTO IRIS/AUTO GAIN UP/AUTO ND (ELC) detected peak to average can be adjusted within a predetermined range.

3. Photometric Measurement Method Setting

[Light Area: All, Center, Top cut, BTM cut, R/L cut]

A photometric measurement method can be selected for AUTO IRIS/AUTO GAIN UP/AUTO ND (ELC).

All: All the screen area is measured.

Center: The screen is measured mainly in the center area, about one-third of both the top and bottom and one-third of both the right and left portions of the screen are excluded from measurement.

Top cut: About one-third of the top part of the screen is excluded from measurement.

BTM cut: About one-third of the bottom portion of the screen is excluded from measurement.

R/L cut: About one-third of both the right and left portions of the screen are excluded from measurement.

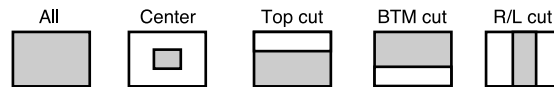

4. Auto ND (ELC) Setting [Auto ND (ELC): ON, OFF]

This cannot be set unless either “OFF” or “Auto” has been set for the CCD storage time setting (①-9).

ON: The electronic shutter is controlled to automatically adjust the luminance.

OFF: Luminance is not automatically adjusted by the electronic shutter.

Notes

- ON is automatically selected when the electronic shutter (⑤-2) on the submenu [Other Set] is set to [Auto ND]. OFF is selected when other than [Auto ND] is selected.
- ON is selected when the SHUTTER switch is set to [ELC] in RCU (RCB) mode, and OFF is selected when it is set to other than [ELC].

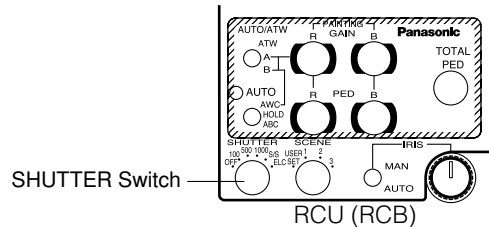

5. Auto Gain Up Control Setting

[Auto Gain Up: OFF, ON]

This cannot be set when “Auto” has been set for the CCD storage time setting (①-9).

OFF: The light quantity is not adjusted automatically.

ON: The light quantity is adjusted automatically. The maximum to which the gain can be increased using the auto gain up function is selected by the AGC maximum gain setting (①-6).

Notes

- In case of settings on the camera alone or when the iris switch on the RCU (RCB) is at [AUTO], the Auto Gain Up control may not operate if the lens iris switch is in the manual position.
- When the AGC switch on the hybrid control panel is set to AGC, the Auto Gain Up control operates in the HIGH position.

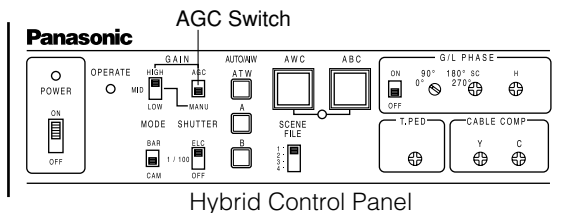

6. AGC Maximum Gain

[AGC Max Gain: 6dB, 12dB, 18dB, 24dB, N/Eye L, N/Eye H] (AW-E750, AW-E655, AW-E650)

[AGC Max Gain: 6dB, 12dB, 18dB, 24dB, N/Eye] (AW-E350)

This is used to set the maximum amount to which the gain can be increased when “ON” has been selected as the auto gain up setting (①-5).

7. Manual Gain Up Control Setting

[Manual Gain Up: 0 dB to 30 dB, N/Eye L, N/Eye H] (AW-E750, AW-E655, AW-E650)

[Manual Gain Up: 0 dB to 30 dB, N/Eye] (AW-E350)

Manual setting is possible only when the Auto Gain Up control (①-5) is in the OFF position.

0 dB: 0 dB should be selected in normal cases.

1 dB to 30 dB: Use this range if sufficient video output cannot be obtained even when the lens iris is opened in shooting dark scenes.

AW-E750, AW-E655, AW-E650

Night Eye L: Use this setting if it is not possible to achieve a satisfactory video output even at 30 dB.

Night Eye H: Use this setting if it is not possible to achieve a satisfactory video output even at the Night Eye L setting.

AW-E350

Night Eye: Use this setting if it is not possible to achieve a satisfactory video output even at 30 dB.

Notes

- Only 0 dB, 9 dB, or 18 dB can be selected in case of using the RCU (RCB).
- 0 dB when the manual GAIN switch on the hybrid control panel is at LOW, 9 dB when it is at MID, or 18 dB when it is at HIGH.

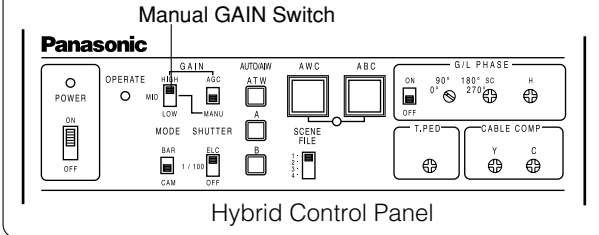

8. Digital Gain Up Setting

[Digital Gain Up: 0dB, 6dB, 12dB, 18dB, 24dB, 30dB]

This can be set only when "OFF" has been selected as the auto gain up setting (1-5).

0 dB: Under normal circumstances, this setting is used.

6 dB to 30 dB: Use this setting while shooting dark scenes if it is not possible to achieve a satisfactory video output even when the lens diaphragm is opened and "Night Eye" is selected as the manual gain up setting (1-7).

9. CCD Storage Time Setting

[Charge Time: Auto, OFF, 1/30s, 1/15s, 1/8s, 1/4s, 1/2s, 1s, 2s]

This is used to set the CCD storage time.

Auto: ALC is performed followed by AGC and then by the data storage, and the camera automatically adjusts the light quantity.

If "ON" is selected as the auto ND (ELC) setting (1-4), ELC is performed followed by ALC, AGC and then by the data storage in this order, and the light quantity is automatically adjusted.

The electronic shutter setting (5-2) cannot be changed.

OFF: Under normal circumstances, this setting is used.

1/30s to 2s: Use this setting if it is not possible to achieve a satisfactory video output even when the gain up setting is used.

The auto ND (ELC) setting (1-4) and electronic shutter setting (5-2) go "OFF" and cannot be changed.

* If the images (CCD read out (mode) setting (5-4)) have been set to "Fine", 1/15s to 2s is selected as the storage time setting, and the sensitivity is set to about one-half of that obtained with when they have been set to "Normal".

10. Black Level Setting [Pedestal: -150 to +150]

The black level (pedestal) of the luminance (Y) signal can be set. Used in adjusting the black levels of two or more cameras.

② Color Set Display

1. Chroma Level Adjustment

[Chroma Level: -3 to +3]

Chroma Level can be decreased or increased to any of three levels each.

2. Skin Color Adjustment [Flesh Tone: -3 to +3]

Skin color can be decreased or increased to any of three levels each.

3. White Balance Setting

[White Bal: ATW, AWC A, AWC B, P SET 3 200K, P SET 5 600K]

ATW: The white balance is automatically adjusted to be always right.

AWC A, AWC B: Once the white balance is adjusted with the ITEM/AWC switch on the back of the camera, it is no longer necessary to set the white balance again if you simply select AWC A or AWC B, provided that the camera is used under the same conditions.

Fine color adjustment can be made after setting AWC by red/blue gain adjustment in user mode or from the RCU (RCB).

P SET 3 200K: The white balance is adjusted to 3 200K illumination.

P SET 5 600K: The white balance is adjusted to 5 600K illumination.

Note

Neither P SET 3 200K nor P SET 5 600K can be set from the RCU (RCB) or the hybrid control panel.

4. ATW Speed Setting

[ATW Speed: SLOW 2, SLOW 1, MID, FAST 1, FAST 2]

ATW Speed can be set.

5. Negative/Positive Selection

[Nega/Posi: Posi, Nega]

Posi: Normal image

Nega: Image is shown reversed in darkness and color.

③ G/L Adjustment Set Display

1. Horizontal Phase Adjustment

[H Phase: -206 to +49]

Horizontal phase can be adjusted when a genlock signal is supplied.

2. Sub Carrier Phase Coarse Adjustment

[SC Coarse: 1, 2, 3, 4]

Coarse adjustment of subcarrier phase can be made when a genlock signal is supplied.

3. Subcarrier Phase Fine Adjustment

[SC Fine: -511 to +511]

Fine adjustment of subcarrier phase can be made when a genlock signal is supplied.

4. Color Bar Setup Setting

[Color Bar Set: 0.0 IRE, 7.5 IRE]

The setup level of color bar can be adjusted.

4 Sharpness (DTL) Set Display

1. Detail Select Setting

[DTL Select: Sharpness, Super DTL]

If contour correction is not sufficient at the Sharpness position when Detail Level setting is set to LOW or HIGH, select the Super DTL position.

Note

Neither Sharpness nor Super DTL is valid for contour correction if Detail Level setting is in the OFF position.

2. Detail Level Setting [Level: OFF, LOW, HIGH]

Detail level can be adjusted when Detail Select setting is at Normal. Super DTL level can be adjusted when it is at Super DTL.

In case of using the RCU (RCB), the above can be adjusted with the contour correction switch (DTL).

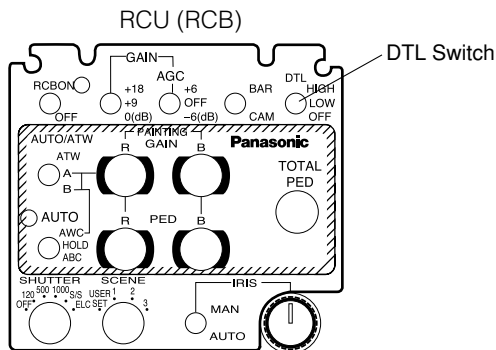

3. Noise Suppress Level Setting

[Noise Suppress: OFF, LOW, HIGH]

Screen noise can be reduced when Detail Level setting (4-2) is at HIGH or LOW.

4. Clean DNR Setting [Clean DNR: HIGH, LOW, OFF]

This enables the clean DNR effect to be selected.

5. 3D-DNR Setting [3D-DNR: OFF, Low, Mid, High]

This enables the 3D-DNR effect to be selected.

* When "Mid" or "High" is selected, the noise is reduced but lag increases.

6. DTL Flesh Tone Setting

[DTL Flesh Tone: LOW, MID, HIGH]

LOW: The roughness of the flesh tones is minimized.

MID: This is the standard setting.

HIGH: The outline compensation for the flesh tones is accentuated.

5 Other Set Display

1. Contrast Adjustment

[Contrast (Gamma): LOW, MID, HIGH]

The contrast can be adjusted to any of three levels.

2. Electronic Shutter Setting

[Shutter Speed: OFF, 1/100 to 1/10 000, S/Scan, Auto ND]

OFF: Electronic shutter is turned off.

1/100, 1/250, 1/500, 1/1 000, 1/2 000, 1/4 000, 1/10 000:

Electronic shutter operates at one of these speeds as selected.

S/Scan (Synchro Scan): Electronic shutter operates at the speed set with the electronic shutter synchro-scan setting (5-1).

Auto ND: Electronic shutter is controlled to automatically adjust the luminance. (ELC)

Notes

- In case of using the RCU (RCB), none of the shutter speeds – 1/250, 1/2 000, 1/4 000, and 1/10 000 can be selected.
- In case of using the hybrid control panel, only OFF, 1/100, or Auto ND (ELC) can be selected.
- If the lens iris switch is at M (Manual) when operating the camera alone or when the iris switch on the RCU (RCB) is at AUTO, Auto ND may not function. Set the lens iris switch to A (Auto).
- Flickering may increase at Auto ND under fluorescent lights.
- Auto ND is automatically selected if Auto ND (ELC) setting is set to ON.

3. Electronic Shutter Synchro Scan Setting

[Synchro Scan: 60.34Hz to 15.75kHz]

This setting is possible only when Electronic Shutter setting (5-2) is at S/Scan.

Horizontal bar noise can be reduced by synchro-scan adjustment in shooting workstation scenes, for example.

✳ For luminance settings at each shutter speed and synchro-scan shutter speed, refer to the table below.

Shutter Speed	Synchro-scan	Required luminance ratio
OFF	—	1
1/100	100.3 Hz	2
1/250	250.0 Hz	4
1/500	492.2 Hz	8
1/1 000	984.4 Hz	16
1/2 000	1.969 kHz	32
1/4 000	3.938 kHz	64
1/10 000	7.875 kHz	160

4. CCD Read Out Mode Setting

[V Resolution: Normal, Fine]

Normal: Normal image. (CCD storage will be by field storage.)

Fine: Vertical resolution increases. (Vertical resolution is raised without increasing residual images by frame storage and Electronic shutter.)

Normal is recommended for general use because sensitivity will decrease at the Fine setting.

5. PC Control Access Speed Setting

[Baud Rate: 1 200bps, 2 400bps, 4 800bps, 9 600bps]

Select a communication speed in controlling the camera from the computer.

6. Component Output Setting

[Component: RGB, Y/Pr/Pb, Y/C]

This enables RGB, Y/Pr/Pb or Y/C to be selected as the component signals which are to be output from the I/F REMOTE connector.

7. Digital Extender Setting

[Digital Extender: OFF, ON]

OFF: Under normal circumstances, this setting is used.

ON: An extender effect which is approximately 1.5 times greater is achieved.
However, the resolution drops when the digital extender is set to "ON".

8. Fan Setting [Fan: OFF, Auto]

(models AW-E750, AW-E655 only)

OFF: Select this setting to stop the fan when its operating sound is found to be bothersome in a studio or other such environment.

Auto: The temperature is detected automatically, and the fan starts operating when the temperature exceeds approx. 10°C in the storage mode or approx. 35°C in any other mode.
Under normal circumstances, the "Auto" setting is used.

9. Auto Focus Setting [Auto Focus: OFF, ON] (model AW-E655 only)

This enables auto focus ON and OFF to be controlled when the zoom/focus cable of a Canon AF lens has been connected to the ZOOM/FOCUS connector on the AW-E655.

10. Filter Setting

**[Filter: IR Through, Normal, 1/16ND, 1/64ND]
(model AW-E655 only)**

IR Through: The infrared shooting mode is established. Irradiate the subject with infrared light.

Normal: Under normal circumstances, this setting is used.

1/16ND: The 1/16 ND filter is inserted. Use this setting when the lens cannot be stopped down enough by the diaphragm.

1/64ND: The 1/64 ND filter is inserted. Use this setting when the lens cannot be stopped down enough by the diaphragm even at the 1/16ND setting.

■ Sub Menu (User Mode)

⑥ Iris, Shutter, Gain Set Display

```

**Iris,Shutter,Gain Set**
1---- Picture Level          ±0
2---- Light PEAK/AVG        ±0
3---- Light Area            Top Cut
4---- Auto Iris Adjust      OFF
5---- Shutter Mode          (Step)
6---- Step/Synchro         (OFF)
7---- Gain                  (0dB)
8---- Digital Gain Up       0dB
9---- AGC Max Gain          (---)
10--- Charge Time           OFF
      Return
  
```

⑧ G/L Adjustment Set Display

```

**G/L Adjustment Set**
1---- H Phase                (±0)
2---- SC Coarse              ( 1)
3---- SC Fine                 (±0)
4---- Color Bar Set          7.5IRE
      Return
  
```

⑨ Detail Set Display

```

**Detail Set1**
1---- Detail                  (High)
2---- H Detail Level H       11
3---- V Detail Level H       6
4---- H Detail Level L       7
5---- V Detail Level L       3
6---- Detail Band            2
7---- Noise Suppress         3
8---- Level Dependent        0%
9---- Dark Detail            0
      Return
  
```

⑦ Color Set Display

```

**Color Set**
1---- Chroma Level           ±0
2---- White Bal              (AWC A)
3---- ATW Speed              Mid
4---- Pedestal                (±0)
   --- Painting
   |  R Gain                  (±0)
   |  B Gain                  (±0)
   |  R Pedestal              (±0)
   |  B Pedestal              (±0)
5---- Nega/Posi              Posi
      Return
  
```

```

**Detail Set2**
10--- Chroma Detail          0
11--- Flesh DTL Level        Mid
12--- Corner Detail          OFF
13--- Precision Detail       OFF
      Return
  
```

- Settings enclosed in parentheses can be set with the RCU (RCB) switch or VR in RCU (RCB) mode.
- To return to the initial settings, refer to page 56.

⑩ Color Matrix Set Display

Color Matrix Set 1

B_Mg Gain	±0
B_Mg Phase	±0
Mg Gain	±0
Mg Phase	±0
Mg_R Gain	±0
Mg_R Phase	±0
R Gain	±0
R Phase	±0

Color Matrix Set 2

R_Yl Gain	±0
R_Yl Phase	±0
Yl Gain	±0
Yl Phase	±0
Yl_G Gain	±0
Yl_G Phase	±0
G Gain	±0
G Phase	±0

Color Matrix Set 3

G_Cy Gain	±0
G_Cy Phase	±0
Cy Gain	±0
Cy Phase	±0
Cy_B Gain	±0
Cy_B Phase	±0
B Gain	±0
B Phase	±0

Return

⑪ Other Set Display

Other Set1

1	Gamma	0.45
2	Knee Point	98%
3	White Clip	110%
4	Flare R	0
	Flare G	0
	Flare B	0
5	Black Stretch	OFF
6	Clean DNR	OFF
7	3D-DNR	OFF
8	2D LPF	OFF

Return

Other Set2

9	Field/Frame	Field
10	Baud Rate	9600bps
11	Component	Y/Pr/Pb
12	Digital Extender	OFF
13	Fan	Auto
14	Auto Focus	OFF
15	Filter	Normal

Return

■ Setting and Changing of the Setting Items (User Mode)

⑥ Iris, Shutter, Gain Set Display

1. Video Level Adjustment [Picture Level: -50 to +50]

Convergence level of AUTO IRIS/AGC/ELC can be adjusted.

2. Detecting Ratio Adjustment

[Light PEAK/AVG: P50 to A50]

The ratio of AUTO IRIS/AGC/ELC detected peak to average can be adjusted within a range.

3. Photometric Measurement Method Setting

[Light Area: All, Center, Top cut, BTM cut, R/L cut]

A photometric measurement method can be selected for AUTO IRIS/AGC/ELC.

All: All the screen area is measured.

Center: The screen is measured mainly in the center area, about one-third of both the top and bottom and one-third of both the right and left portions of the screen are excluded from measurement.

Top cut: About one-third of the top portion of the screen is excluded from measurement.

BTM cut: About one-third of the bottom portion of the screen is excluded from measurement.

R/L cut: About one-third of both the right and left portions of the screen are excluded from measurement.

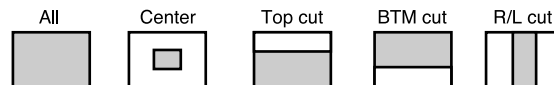

4. Auto Iris Level Fine Adjustment

[Auto Iris Adjust: ON, OFF]

ON: Fine adjustment of auto iris convergence level can be made with the iris control when the iris switch on the RCU (RCB) or on the hybrid control panel is in the AUTO position.

OFF: The iris control is invalid when the iris switch on the RCU (RCB) or on the hybrid control panel is in the AUTO position.

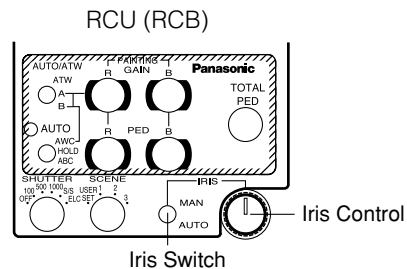

5. Electronic Shutter Mode Setting

[Shutter Mode: Step, ELC, S/Scan]

Step: Electronic shutter operates at the speed selected by the Electronic Shutter Step/Synchro Scan Setting (6-6).

ELC: Electronic shutter is controlled to automatically adjust the luminance.

S/Scan (Synchro Scan): Electronic shutter operates at the speed selected in Electronic Shutter Step/Synchro Scan Setting (6-6).

Note

If Frame 1 is selected in CCD Read Out Mode Setting (11-9), Electronic Shutter Mode Setting cannot be added.

6. Electronic Shutter Step/Synchro Scan Setting

[Step/Synchro: OFF, 1/100 to 1/10 000 (step), 60.34Hz to 15.75kHz (Synchro Scan)]

This can be set when “Step” or “Synchro Scan” has been selected as the electronic shutter mode setting (6-5).

- When “Step” has been selected as the electronic shutter mode setting (6-5):

OFF: The electronic shutter is set to OFF.

1/100, 1/250, 1/500, 1/1 000, 1/2 000, 1/4 000, 1/10000:

The electronic shutter operates at the shutter speed selected.

- When “Synchro Scan” has been selected as the electronic shutter mode setting (6-5):

When the screen of a work station, etc. is to be shot, the noise on the horizontal bars can be reduced by proceeding with the synchro-scan adjustment.

- * Refer to the table below for the light quantity settings to be used in each shutter mode and during synchro scanning.

Shutter Speed	Synchro-scan	Required luminance ratio
OFF	—	1
1/100	100.3 Hz	2
1/250	250.0 Hz	4
1/500	492.2 Hz	8
1/1 000	984.4 Hz	16
1/2 000	1.969 kHz	32
1/4 000	3.938 kHz	64
1/10 000	7.875 kHz	160

Notes

- In case of using the RCU (RCB), none of the shutter speeds – 1/250, 1/2 000, 1/4 000, and 1/10 000 can be selected.
- In case of using the hybrid control panel, only OFF, 1/100, or ELC can be selected.
- If the lens iris switch is at M (Manual) when operating the camera alone or when the iris switch on the RCU (RCB) is at AUTO, ELC may not function. Set the lens iris switch to A (Auto).
- Flickering may increase at ELC under fluorescent lights.

7. Gain Setting

**[Gain: Auto, 0 dB to 30 dB, N/Eye L, N/Eye H]
(models AW-E750, AW-E655, AW-E650)**

**[Gain: Auto 0 dB to 30 dB, N/Eye]
(model AW-E350)**

When “Auto” has been selected as the CCD storage time setting (6-10), the setting is kept to “Auto” regardless of the gain setting selected here.

Auto: The light quantity is adjusted automatically.

0 dB: Under normal circumstances, this setting is used.

1 dB to 30 dB: Use this setting while shooting dark scenes if it is not possible to achieve a satisfactory video output even when the lens diaphragm is opened.

AW-E750, AW-E655, AW-E650

N/Eye L (Night Eye L) : Use this setting if it is not possible to achieve a satisfactory video output even at 30 dB.

N/Eye H (Night Eye H) : Use this setting if it is not possible to achieve a satisfactory video output even at the Night Eye L setting.

AW-E350

N/Eye (Night Eye) : Use this setting if it is not possible to achieve a satisfactory video output even at 30 dB.

Notes

- Only 0 dB, 9 dB, or 18 dB, AGC LOW, AGC HIGH can be selected in case of using the RCU (RCB). If the lens iris switch is at MANUAL, when operating the camera alone or when the iris switch on the RCU (RCB, Hybrid control panel) is at AUTO, AGC may not function.
- AGC HIGH when the AGC selection switch on the hybrid control panel is at AGC.
- 0 dB when the manual gain switch on the hybrid control panel is at LOW, 9 dB when it is at MID, or 18 dB when it is at HIGH.

Manual GAIN Switch AGC Switch

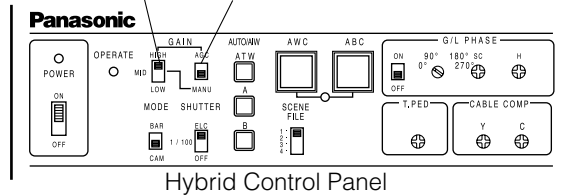

8. Digital Gain Up Setting

[Digital Gain Up: 0dB, 6dB, 12dB, 18dB, 24dB, 30dB]

This can be set when a setting other than "Auto" has been selected as the gain setting (6-7).

0 dB: Under normal circumstances, this setting is used.

6 dB to 30 dB: Use this setting while shooting dark scenes if it is not possible to achieve a satisfactory video output even when the lens diaphragm is opened and "Night Eye" is selected as the gain setting (6-7).

9. AGC Maximum Gain Setting

[AGC Max Gain: 6dB, 12dB, 18dB, 24dB, N/Eye L, N/Eye H] (AW-E750, AW-E655, AW-E650)

[AGC Max Gain: 6dB, 12dB, 18dB, 24dB, N/Eye] (AW-E350)

This is used to set the maximum gain up when "Auto" has been selected as the gain setting (6-7).

10. CCD Storage Time setting

[Charge Time: Auto, OFF, 1/30s, 1/15s, 1/8s, 1/4s, 1/2s, 1s, 2s]

This is used to set the CCD storage time.

OFF: Under normal circumstances, this setting is used.

Auto: ALC is performed followed by AGC and then by the data storage, and the camera automatically adjusts the light quantity.

If the electronic shutter mode setting (6-5) is set to "ELC", ELC is performed followed by ALC, AGC and then by the data storage in this order, and the light quantity is automatically adjusted. The electronic shutter mode setting (6-5) cannot be changed at this time.

1/30s to 2s: Use this setting if it is not possible to achieve a satisfactory video output even when the gain up setting is used.

The electronic shutter go "OFF" at this time, the electronic shutter mode setting (6-5) and electronic shutter step/synchro scan setting (6-6) cannot be changed.

* If the CCD read out (mode) setting (11-9) has been set to "Frame1" or "Frame2", 1/15s to 2s is selected as the storage time setting, and the sensitivity is set to about one-half of that obtained with when the CCD read-out (mode) setting (11-9) has been set to "Field".

7 Color Set Display

1. Chroma Level Adjustment [Chroma Level: -3 to +3]

Chroma Level can be decreased or increased to three levels.

2. White Balance Setting

[White Bal: ATW, AWC A, AWC B, P SET 3 200K, P SET 5 600K]

ATW: The white balance is automatically adjusted to the optimum position.

AWC A, AWC B: Color temperature conditions at two points can be stored at AWC A and AWC B. Once the white balance is adjusted with the ITEM/AWC switch on the back of the camera, it is no longer necessary to set the white balance again if you simply select AWC A or AWC B, provided that the camera is used under the same conditions.

Fine color adjustment can be made after setting AWC by red/blue gain adjustment in Painting Setting or from the RCU (RCB).

P SET 3 200K: The white balance is adjusted to 3 200K illumination.

P SET 5 600K: The white balance is adjusted to 5 600K illumination.

Note

Neither P SET 3 200K nor P SET 5 600K can be set from the RCU (RCB) or the hybrid control panel.

3. ATW Speed Setting

[ATW Speed: SLOW 2, SLOW 1, MID, FAST 1, FAST 2]
ATW Speed can be set.

4. Black Level Setting [Pedestal: -150 to +150]

The black level (pedestal) of the luminance (Y) signal can be set. Used in adjusting the black levels of two or more cameras.

5. Painting Setting

[Painting: R Gain, B Gain, R Pedestal, B Pedestal: -150 to +150]

R Gain, B Gain: Fine adjustment of the white balance can be made after AWC setting when AWC A or AWC B is selected in White Balance Setting. In case of using the RCU (RCB), use the R/B gain controls for this purpose. The set value returns to ± 0 after AWC setting in using the camera alone.

R Pedestal, B Pedestal: Fine adjustment of the black balance can be made after ABC setting.

In case of using the RCU (RCB), use the R/B pedestal controls for this purpose. The set value returns to ± 0 after ABC setting in using the camera alone.

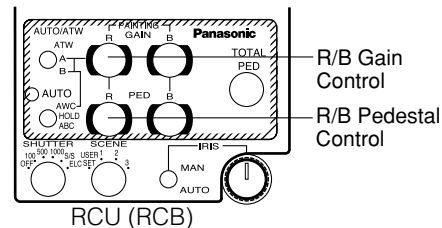

6. Negative/Positive Selection

[Nega/Posi: Posi, Nega]

Posi: Normal image

Nega: Image is shown reversed in darkness and color.

8 G/L Adjustment Set Display

1. Horizontal Phase Adjustment

[H Phase: -206 to +49]

Horizontal phase can be adjusted when a genlock signal is supplied.

2. Subcarrier Phase Coarse Adjustment

[SC Coarse: 1, 2, 3, 4]

Coarse adjustment of subcarrier phase can be made when a genlock signal is supplied.

3. Subcarrier Phase Fine Adjustment

[SC Fine: -511 to +511]

Fine adjustment of subcarrier phase can be made when a genlock signal is supplied.

4. Color Bar Setup Setting

[Color Bar Set: 0.0 IRE, 7.5 IRE]

The setup level of color bar can be adjusted.

9 Detail Set Display

1. Detail Level Setting [Detail: OFF, Low, High]

Contour correction quantity can be selected.

Detail settings made using the Horizontal/Vertical Detail Level HIGH/LOW Setting.

2. Horizontal Detail Level HIGH Setting

[H Detail Level H: L+1 to +63]

3. Vertical Detail Level HIGH Setting

[V Detail Level H: L+1 to +31]

4. Horizontal Detail Level LOW Setting

[H Detail Level L: 0 to H-1]

5. Vertical Detail Level LOW Setting

[V Detail Level L: 0 to H-1]

Detail level can be set in horizontal (H) and vertical (V) directions with the Detail Level Setting (9-1) at HIGH or LOW.

Whichever the direction, H or V, the set level at HIGH must be at least one position higher than that at LOW.

6. Detail Band Setting [Detail Band: 1 to 5]

A contour correction band can be set with the Detail Level Setting (9-1) at HIGH or LOW. The higher setting, the finer will be the detail.

7. Noise Suppress Compensation Level Setting

[Noise Suppress: 1 to 10]

Screen noise can be reduced with the Detail Level Setting (🔊-1) at HIGH or LOW. If the noise suppress compensation level is set too high, a fine object will be reproduced less sharply.

8. Level Dependent Compensation Level Setting

[Level Dependent: 0% to 25%]

Screen noise due to the detail of dark parts of an object can be reduced.

If level dependent compensation level is set too high, however, hair, for example, will be reproduced less sharply.

9. Dark Detail Compensation Level Setting

[Dark Detail: 0 to 5]

The contours of the darker portions of an object can be emphasized.

This setting is possible only when the Level Dependent Compensation Level Setting (🔊-9) is set to 0 %.

10. Chroma Detail Compensation Level Setting

[Chroma Detail: 0 to 15]

The contours of high-hue portions of an object can be emphasized.

11. Flesh DTL Level Setting

[Flesh DTL Level: Low, Mid, High]

LOW: The roughness of the flesh tones is minimized.

MID: This is the standard setting.

HIGH: The outlines of the flesh tones are accentuated.

12. Corner Detail Setting [Corner Detail: OFF, ON]

Corner detail, which improves the resolution of corners, can be turned on or off when the Detail Level Setting (🔊-1) is at HIGH or LOW.

13. Precision Detail Level Setting

[Precision Detail: OFF, LOW, HIGH]

This setting is to narrow detail width and suppress detail glare.

⑩ Color Matrix Set Display

B_Mg Gain: Increases or decreases the intermediate color between blue and magenta.

B_Mg Phase: Varies the hue of the intermediate color between blue and magenta.

Mg Gain: Increases or decreases the magenta.

Mg Phase: Varies the hue of the magenta.

Mg_R Gain: Increases or decreases the intermediate color between magenta and red.

Mg_R Phase: Varies the hue of the intermediate color between magenta and red.

R Gain: Increases or decreases the red.

R Phase: Varies the hue of the red.

R_YI Gain: Increases or decreases the intermediate color between red and yellow.

R_YI Phase: Varies the hue of the intermediate color between red and yellow.

YI Gain: Increases or decreases the intermediate color of yellow.

YI Phase: Varies the hue of the yellow.

YI_G Gain: Increases or decreases the intermediate color between yellow and green.

YI_G Phase: Varies the hue of the intermediate color between yellow and green.

G Gain: Increases or decreases the green.

G Phase: Varies the hue of the green.

G_Cy Gain: Increases or decreases the intermediate color between green and cyan.

G_Cy Phase: Varies the hue of the intermediate color between green and cyan.

Cy Gain: Increases or decreases the cyan.

Cy Phase: Varies the hue of the cyan.

Cy_B Gain: Increases or decreases the intermediate color between cyan and blue.

Cy_B Phase: Varies the hue of the intermediate color between cyan and blue.

B Gain: Increases or decreases the intermediate color between blue and magenta.

B Phase: Varies the hue of the intermediate color between blue and magenta.

⑪ Other Set Display

1. Gamma Correction Level Setting

[Gamma: 0.35 to 0.55]

Gamma correction level can be set.

2. Knee Compensation Level Setting

[Knee Point: 88% to 98%, Dynamic]

88% to 98%: The level of video signals subject to knee compensation (knee point) can be set.

Dynamic: Knee compensation level is automatically adjusted according to the scene.

3. White Clip Level Setting

[White Clip: 95% to 110%]

The peak level of video signals to be white-clipped can be set.

4. Flare Correction Level Setting

[Flare R/G/B: 0 to 100]

Flare correction level can be adjusted.

* Flare correction level has already been adjusted prior to shipment from the factory.

5. Black Stretch Setting [Black Stretch: ON, OFF]

Black stretch to correct the suppression of black portions at low luminance can be set to ON or OFF.

6. Clean DNR Setting [Clean DNR: HIGH, LOW, OFF]

This enables the clean DNR effect to be selected.

7. 3D-DNR Setting [3D-DNR: OFF, Low, Mid, High]

This enables the 3D-DNR effect to be selected.

* When “Mid” or “High” is selected, the noise is reduced but lag increases.

8. 2-dimensional Lowpass Filter Setting

[2D LPF: OFF, LOW, HIGH]

The 2D lowpass filter that reduces moire and cross color can be set.

9. CCD Read Out Mode Setting

[Field/Frame: Field, Frame 1, Frame 2]

Field: CCD storage will be by field storage.

Frame 1: Vertical resolution increases in frame storage.

Frame 2: Vertical resolution is raised without increasing residual images by frame storage and electronic shutter.

10. PC Control Access Speed Setting

[Baud Rate: 1 200bps, 2 400bps, 4 800bps, 9 600bps]

This setting is to select a communication speed in controlling the camera from the computer.

11. Component Output Setting

[Component: RGB, Y/Pr/Pb, Y/C]

This enables RGB, Y/Pr/Pb or Y/C to be selected as the component signals which are to be output from the I/F REMOTE connector.

12. Digital Extender Setting [Digital Extender: OFF, ON]

OFF: Under normal circumstances, this setting is used.

ON: An extender effect which is approximately 1.5 times greater is achieved. However, the resolution drops when the digital extender is set to "ON".

13. Fan Setting [Fan: OFF, Auto]

(models AW-E750, AW-E655)

OFF: Select this setting to stop the fan when its operating sound is found to be bothersome in a studio or other such environment.

Auto: The temperature is detected automatically, and the fan starts operating when the temperature exceeds approx. 10°C in the storage mode or approx. 35°C in any other mode. Under normal circumstances, the "Auto" setting is used.

14. Auto Focus Setting [Auto Focus: OFF, ON] (model AW-E655)

This enables auto focus ON and OFF to be controlled when the zoom/focus cable of a Canon AF lens has been connected to the ZOOM/FOCUS connector on the AW-E655.

15. Filter Setting

[Filter: IR Through, Normal, 1/16ND, 1/64ND]

IR Through: The infrared shooting mode is established. Irradiate the subject with infrared light.

Normal: Under normal circumstances, this setting is used.

1/16ND: The 1/16 ND filter is inserted. Use this setting when the lens cannot be stopped down enough by the diaphragm.

1/64ND: The 1/64 ND filter is inserted. Use this setting when the lens cannot be stopped down enough by the diaphragm even at the 1/16ND setting.

SETTING AND CHANGING THE OPTIONAL CARDS

⑫ Optional Card Setting Sub Menu

This sub menu appears when a studio card (AW-PB506 or AW-PB305) has been inserted into the optional card slot.

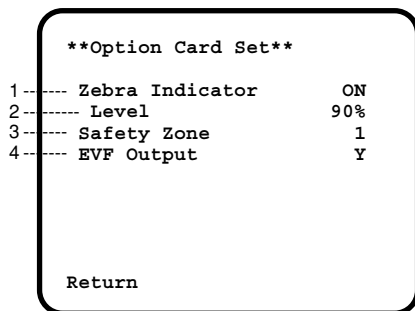

* The sub menu shown below appears only when an optional card (AW-PB504) equipped with a ZOOM/FOCUS connector has been inserted in the model AW-E650.

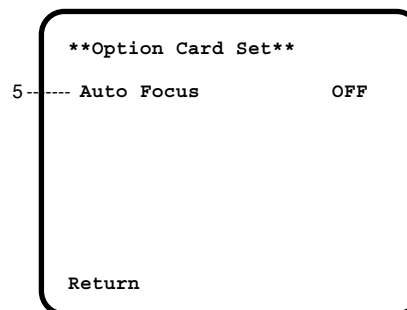

1. Zebra Indicator Setting [Zebra Indicator: ON, OFF]

This is used to select whether to display the zebra pattern on the viewfinder.

ON: The zebra pattern is displayed on the viewfinder.

OFF: The zebra pattern is not displayed on the viewfinder.

* If "CVBS" is selected as the EVF output setting (⑫-4), the zebra pattern will not be displayed on the viewfinder even when "ON" has been set for the zebra pattern display.

2. Zebra Level Setting [Level: 70% to 110%]

This enables the zebra pattern to be displayed so that it will provide as a general guideline for the luminance level.

* It can be set when “ON” has been selected as the zebra indicator setting (10-1).

3. Safety Zone Setting [Safety Zone: OFF, 1, 2, 3, 4, 5]

This is used to select the type of safety zone which is displayed on the viewfinder. A safety zone is not displayed when “OFF” is selected.

* The safety zone and center marker indicate electrical positions and, as such, they may be at variance with their optical positions.

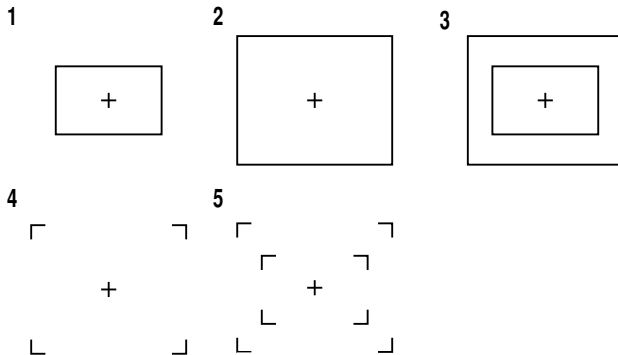

The inside and outside frames denote safety zones of about 90% and about 95%, respectively.

4. EVF Output Setting [EVF Output: Y, CVBS]

This is used to set the signals to be output to the viewfinder.

Y: The luminance signal is output to the viewfinder.

CVBS: The color signals are output to the viewfinder.

* When “CVBS” has been selected as the setting, the zebra pattern will not be displayed on the viewfinder.

5. Auto Focus [Auto Focus: OFF, ON]

This enables auto focus ON and OFF to be controlled when the zoom/focus cable of a Canon AF lens has been connected to the ZOOM/FOCUS connector of the optional card.

SETTING TO INITIAL SET

■ Setting to initial set

In case of the wrong setting in any use mode, take the following steps to return to the initial settings.

- (1) Select [Initialize Data] on the main menu screen of each Use Mode. (See page 29.)
Press the YES/ABC switch, then [Initialize Data] screen shown for about 10 seconds.
- (2) Press the YES/ABC switch within about 10 seconds to return to the initial settings, the existing settings

are initialized, the screen shown at ②, and the camera returns to main menu.

- (3) If the NO/BAR switch is pressed, or if the YES /ABC switch is not pressed, within about 10 seconds, the screen shown at ③, and the camera returns to main menu, and the existing settings are not initialized.

Note

If you are using an option card, the Option Card Setting Submenu will not be initialized even if "Return to Initialize" is performed.

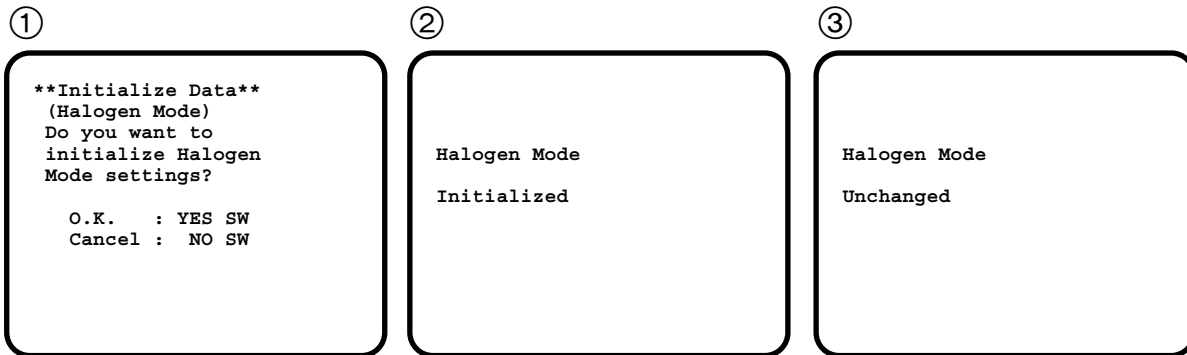

■ INITIAL SETTINGS OF THE SETTING ITEMS (Factory preset values)

● Halogen, Fluorescent, Outdoor Mode

	Item	Halogen mode	Fluorescent mode	Outdoor mode
Brightness Set	Picture Level Light PEAK/AVG Light Area Auto ND (ELC) Auto Gain Up AGC Max Gain Manual Gain Up Digital Gain Up Charge Time Pedestal	±0 0 Top cut OFF OFF --- 0dB 0dB OFF ±0	±0 0 Top cut OFF OFF --- 0dB 0dB OFF ±0	±0 0 Top cut ON ON N/Eye H* ¹ N/Eye * ² --- --- OFF -40
Color Set	Chroma Level Flesh Tone White Bal ATW Speed Nega/Posi	±0 ±0 AWC A --- Posi	±0 ±0 AWC A --- Posi	±0 ±0 ATW Mid Posi
G/L, Color Bar Set	H Phase SC Coarse SC Fine Color Bar Set	±0 1 ±0 7.5 IRE	±0 1 ±0 7.5 IRE	±0 1 ±0 7.5 IRE
Sharpness (DTL) Set	DTL Select Level Noise Suppress Clean DNR 3D-DNR DTL Flesh Tone	Sharpness High OFF OFF OFF Mid	Sharpness High OFF OFF OFF Mid	Sharpness High OFF OFF OFF Mid

*1: AW-E750, AW-E655, AW-E650 *2: AW-E350

● Halogen, Fluorescent, Outdoor Mode

	Item	Halogen mode	Fluorescent mode	Outdoor mode
Other Set	Contrast (Gamma) Shutter Speed Synchro Scan V Resolution Baud Rate Component Digital Extender Fan Auto Focus Filter	Mid OFF --- Normal 9 600bps Y/Pr/Pb OFF Auto OFF Normal	Mid OFF --- Normal 9 600bps Y/Pr/Pb OFF Auto OFF Normal	Mid Auto ND --- Normal 9 600bps Y/Pr/Pb OFF Auto OFF Normal

● User Mode

	Item	User mode		Item	User mode
Iris, Shutter, Gain Set	Picture Level	±0	Color Set	Chroma Level	+2
	Light PEAK/AVG	0		White Bal	AWC A
	Light Area	Top cut		ATW Speed	Mid
	Auto Iris Adjust	OFF		Pedestal	±0
	Shutter Mode	Step		Painting	
	Step/Synchro	OFF		R Gain	±0
	Gain	0dB		B Gain	±0
	Digital Gain Up	0dB		R Pedestal	±0
	AGC Max Gain	---		B Pedestal	±0
	Charge Time	OFF		Nega/Posi	Posi
			G/L, Color Bar Set	H Phase	±0
				SC Coarse	1
				SC Fine	±0
				Color Bar Set	7.5 IRE

● User Mode

	Item	User mode
Detail Set 1	Detail	High
	H Detail Level H	15
	V Detail Level H	12
	H Detail Level L	8
	V Detail Level L	7
	Detail Band	2
	Noise Suppress Level Dependent	3 0%
	Dark Detail	0
Detail Set 2	Chroma Detail	0
	Flesh DTL Level	Mid
	Corner Detail	OFF
	Precision Detail	OFF
Color Matrix Set 1	B_Mg Gain	±0
	B_Mg Phase	±0
	Mg Gain	+27
	Mg Phase	±0
	Mg_R Gain	±0
	Mg_R Phase	±0
	R Gain R Phase	+15 ±0
Color Matrix Set 2	R_YI Gain	±0
	R_YI Phase	±0
	YI Gain	+18
	YI Phase	+6
	YI_G Gain	±0
	YI_G Phase	±0
	G Gain	+30
	G Phase	+112

	Item	User mode
Color Matrix Set 3	G_Cy Gain	±0
	G_Cy Phase	±0
	Cy Gain	+44
	Cy Phase	-15
	Cy_B Gain	±0
	Cy_B Phase	±0
	B Gain	-20
	B Phase	+36
Other Set 1	Gamma	0.45
	Knee Point	88%
	White Clip	110%
	Flare R	0
	Flare G	0
	Flare B	0
	Black Stretch	OFF
	Clean DNR	OFF
	3D-DNR	OFF
	2D LPF	OFF
Other Set 2	Field/Frame Baud Rate	Field 9 600bps
	Component	Y/Pr/Pb
	Digital Extender	OFF
	Fan	Auto
	Auto Focus	OFF
	Filter	Normal

APPEARANCE

Unit: inch (mm)

(AW-E750)

