

Service Manual

Reciprocating Saw

EY3544-U1

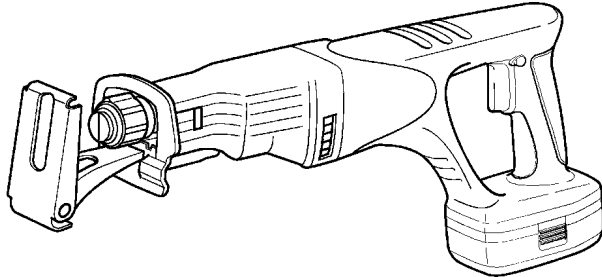

SPECIFICATIONS

MAIN UNIT

Motor	DC Motor 18V
Length of Strokes	23mm (7/8")
Strokes per Minute	0-2700 spm
Type of Blade shank	13mm (1/2") universal reciprocating saw blade
Overall length	491mm (19-5/16")
Weight (with battery pack)	3.9kg (8.7lbs.)

⚠ WARNING

This service information is designed for experienced repair technicians only and is not designed for use by the general public. It does not contain warnings or cautions to advise non-technical individuals of potential dangers in attempting to service a product. Products powered by electricity should be serviced or repaired only by experienced professional technicians. Any attempt to service or repair the product or products dealt with in this service information by anyone else could result in serious injury or death.

CONTENTS

	Page		Page
1 SCHEMATIC DIAGRAM	2	4 TROUBLESHOOTING GUIDE	7
2 DISASSEMBLY INSTRUCTIONS	3	5 EXPLODED VIEW	8
3 ASSEMBLY INSTRUCTIONS	6	6 REPLACEMENT PARTS LIST	9

Panasonic®

© 2003 Matsushita Electric Works Ltd. All rights reserved. Unauthorized copying and distribution is a violation of law.

1 SCHEMATIC DIAGRAM

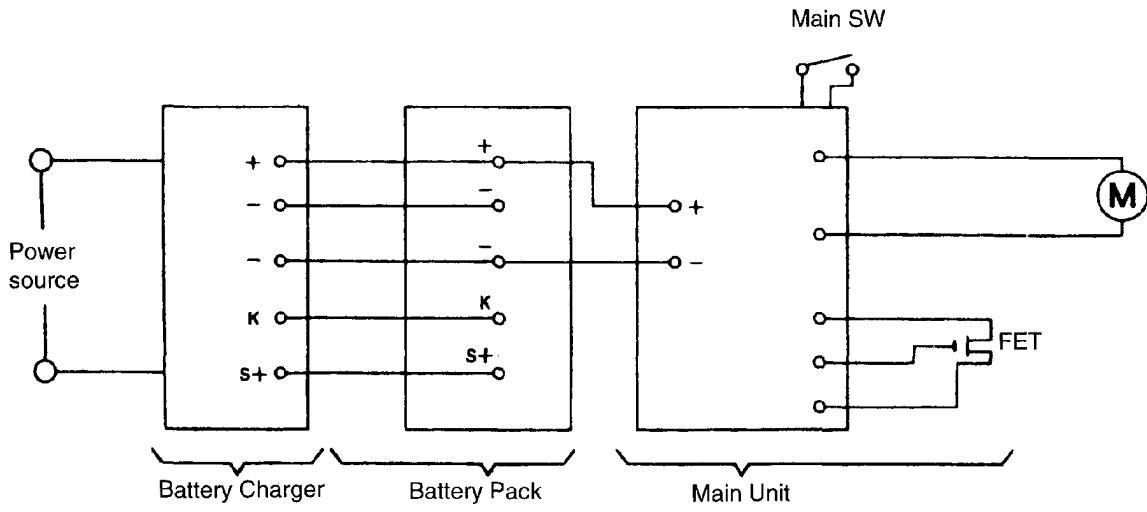

2 DISASSEMBLY INSTRUCTIONS

■HOW TO DISASSEMBLE BLADE CLAMP ASSEMBLY.

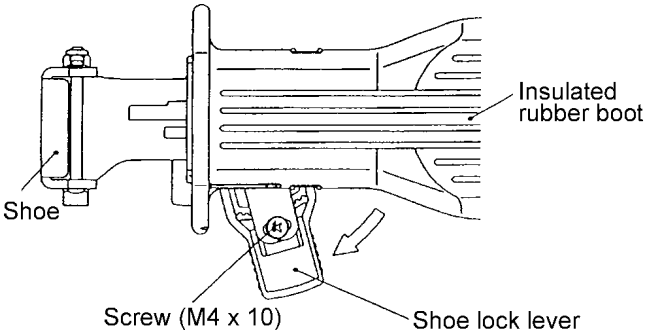
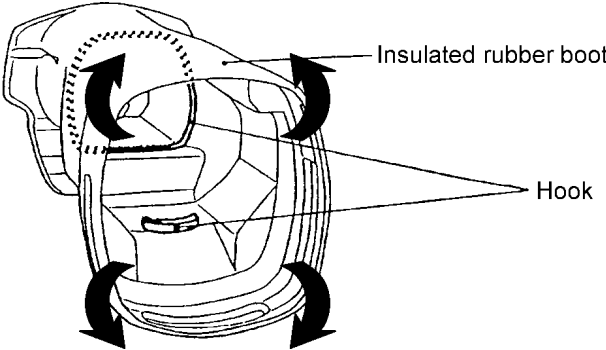
Ref. No. 1A	Procedure 1A	Removal of the shoe.
	 <p>The diagram shows a side view of the blade clamp assembly. A shoe is attached to the left side. A screw (M4 x 10) is shown passing through the shoe lock lever. The insulated rubber boot is shown covering the blade. Labels include: Shoe, Screw (M4 x 10), Shoe lock lever, and Insulated rubber boot.</p>	<p>Removal of the shoe.</p> <ol style="list-style-type: none"> 1. Loosen a screw (M4X10) with washer tightened on the rear side of shoe lock lever. 2. Remove the shoe lock lever and loosen the hexagonal head bolt. <p>NOTE : Make sure not to lose a hexagonal nut (M4) where located inside of the shoe lock lever.</p>
Ref. No. 1B	Procedure 1A → 1B	Removal of the insulated rubber boot.
	 <p>The diagram shows a top-down view of the blade clamp assembly. The insulated rubber boot is being wound down. A hook is shown at the bottom. Labels include: Insulated rubber boot and Hook. Arrows indicate the direction of winding.</p>	<p>1. Wind the insulated rubber boot down started from the motor side.</p> <p>NOTE : The insulated rubber boot may not pull off due to scratched badly inside of the hook.</p>

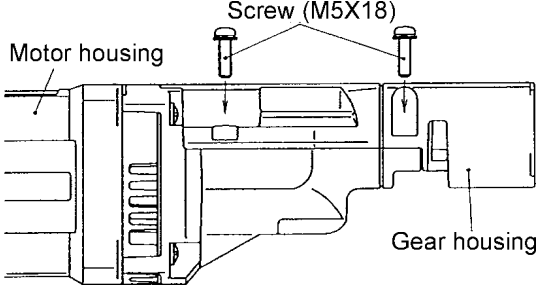
Ref. No. 1C	Procedure 1A → 1B → 1C	Removal of the blade clamp block.
		<ol style="list-style-type: none"> 1. Loosen four screws (M5X18) where tightening on the gear housing.

■HOW TO DISASSEMBLE GEAR CASE or MOTOR ASSEMBLY.

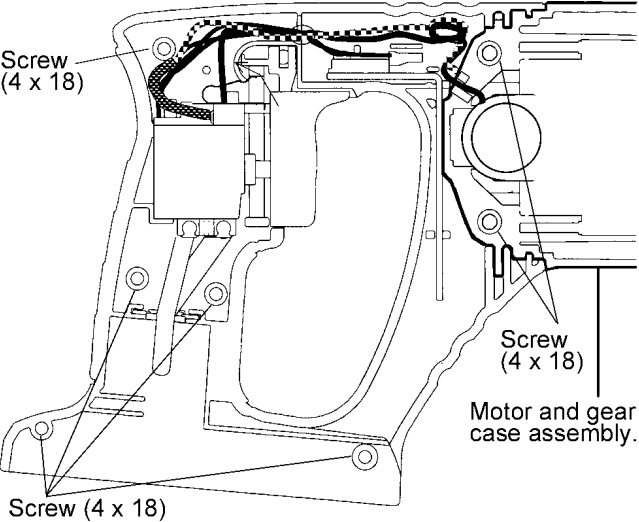
Ref. No. 1D	Procedure 1A → 1B → 1D	Removal of the housing.
		<ol style="list-style-type: none"> 1. Loose seven housing screws (4X18). 2. Open the housing B. 3. Take out the motor with gear case assembly from the housing A.

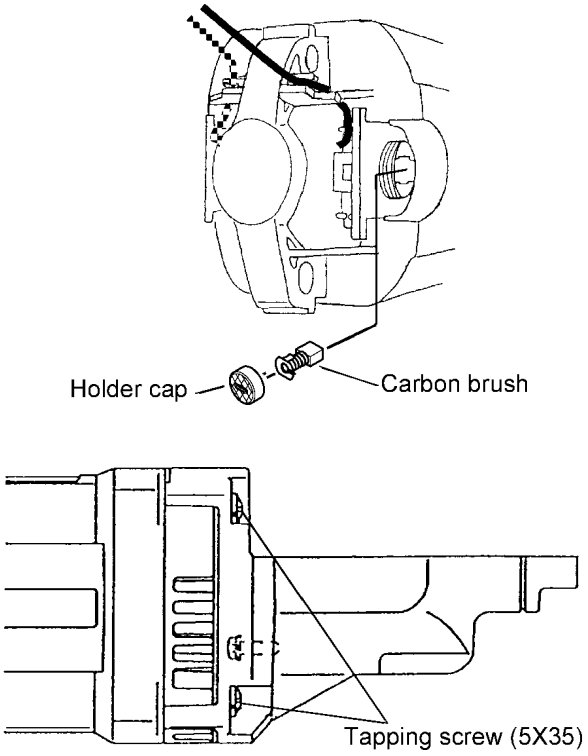
Ref. No. 1E	Procedure 1A → 1B → 1D → 1E	Removal of the motor housing.
 <p data-bbox="272 531 391 558">Holder cap</p> <p data-bbox="581 531 727 558">Carbon brush</p> <p data-bbox="545 884 781 911">Tapping screw (5X35)</p>		<ol style="list-style-type: none"> 1. Remove the holder cap and take out the carbon brush on right and left side. 2. Loosen four tapping screws (5X35) tighten the gear case. 3. Pull out the gear case assembly from the motor housing.

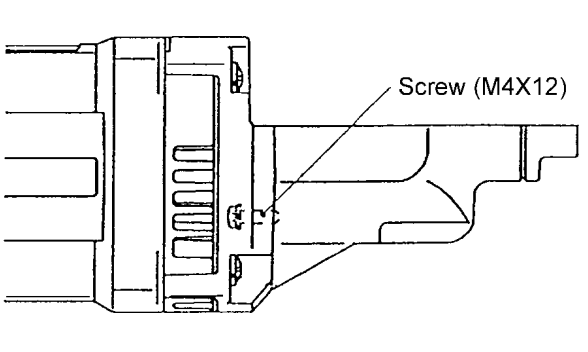
Ref. No. 1F	Procedure 1A → 1B → 1D → 1E → 1F → 1C	Removal of the gear case block.
 <p data-bbox="597 1100 768 1127">Screw (M4X12)</p>		<ol style="list-style-type: none"> 1. Loosen two screws (M4X12) and pull out the rotor assembly. 2. Follow the procedure 1C. <p>NOTE: Greasing No. 1 grease about 10g into the gear for reassembly.</p>

3 ASSEMBLY INSTRUCTIONS

■ HOW TO ASSEMBLE SWITCH.

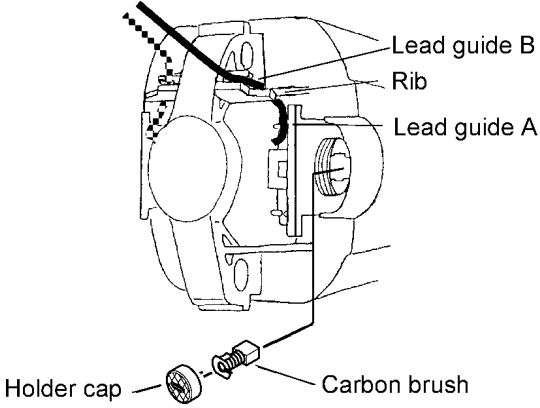
Ref. No. 1A	Procedure 1A	Attachment of the brush holder.
		<ol style="list-style-type: none"> 1. Insert the brush holders on both right and left side. 2. Press fit the lead wires into the lead guide A. 3. Press fit the lead wires into the lead guide B. 4. Insert the carbon brushes. 5. Tighten the holder caps.

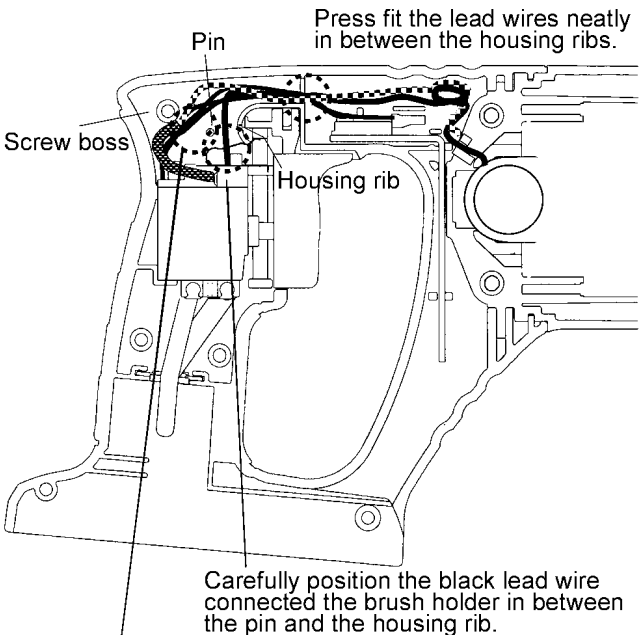
Ref. No. 1B	Procedure 1A → 1B	Attachment of the switch.
	 <p>Press fit the lead wires neatly in between the housing ribs.</p> <p>Carefully position the black lead wire connected the brush holder in between the pin and the housing rib.</p> <p>Carefully position the lead wires in between the pin and the screw boss.</p>	<ol style="list-style-type: none"> 1. Check the lead wires whether they are mounted in the proper position. <p>NOTE: Make sure they are not set on the screw bosses or over the housing ribs.</p>

4 TROUBLESHOOTING GUIDE

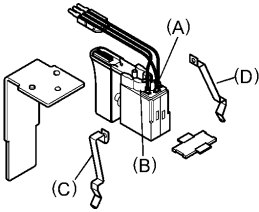
< TROUBLE >	< CHECK >	< REMEDY >	
Does not operate.	<p align="center"><CHECK BATTERY PACK.></p> <p>If no less than 18V DC is available across the (+) and (-) terminals after charging for the rated charging time (approx. 65 minutes for EY9250), the battery pack is OK.</p> <p>NOTE: The battery pack is sold separately as an optional accessory. See the nearest sales dealer for details. The battery pack has a limited life.</p> <p>The pack should be replaced if;</p> <ul style="list-style-type: none"> - after being charged for the rated charging time the battery voltage is less than 18V DC or the usable time is extremely short. - the battery leaks. Check battery for leaks and terminals for corrosion 	NO → Replace battery pack.	
↓OK			
<p align="center"><CHECK TERMINAL CONNECTIONS BETWEEN MAIN UNIT AND BATTERY PACK.></p> <p>Check for proper terminal contacts.</p>			NO → Repair contacts.
↓OK			
<p align="center"><CHECK SWITCH BLOCK.> (See WIRING CONNECTION DIAGRAM.)</p> <p>Check continuity between following terminals.</p> <p>1) Inspection of the switch operated contact.</p> <p>When switch handle is depressed all the way:</p> <ul style="list-style-type: none"> - There should be 0Ω between (A) - (D) , and between (B) - (C) ; when switch lever is set to forward side. <p>2) Inspection of the brake.</p> <p>When switch handle is not depressed:</p> <ul style="list-style-type: none"> - There should be 0Ω between (A) - (B) 			NO → Contacts in switch block are defective. Replace switch & FET block.
			
↓OK			
<p align="center"><CHECK CARBON BRUSH.></p> <p>1) The condition of carbon brush.</p> <ul style="list-style-type: none"> - There should be more than 1mm from the line of the carbon brush. <p>2) The continuity of carbon brush.</p> <ul style="list-style-type: none"> - There should be 0Ωbetween the motor lead wire and the metal fitting of carbon brush. 			NO → Replace carbon brushes.
↓OK			
<p align="center"><CHECK MOTOR ROTOR.></p> <p>Check the condition of rotor if there is any wear, crack and deformation.</p>			NO → Replace motor rotor assembly.
↓OK			
<p align="center"><CHECK MOTOR STATOR.></p> <p>Check the condition of motor case if there is any crack and deformation.</p>			NO → Replace motor stator.
Does not speed-control.	<p align="center"><CHECK SWITCH.></p> <p>Follow the procedure above "CHECK SWITCH". Attach the battery pack and confirm the switch operation when depressing the switch handle little by little.</p>	NO → Repair the contact or replace switch & FET block.	

5 EXPLODED VIEW

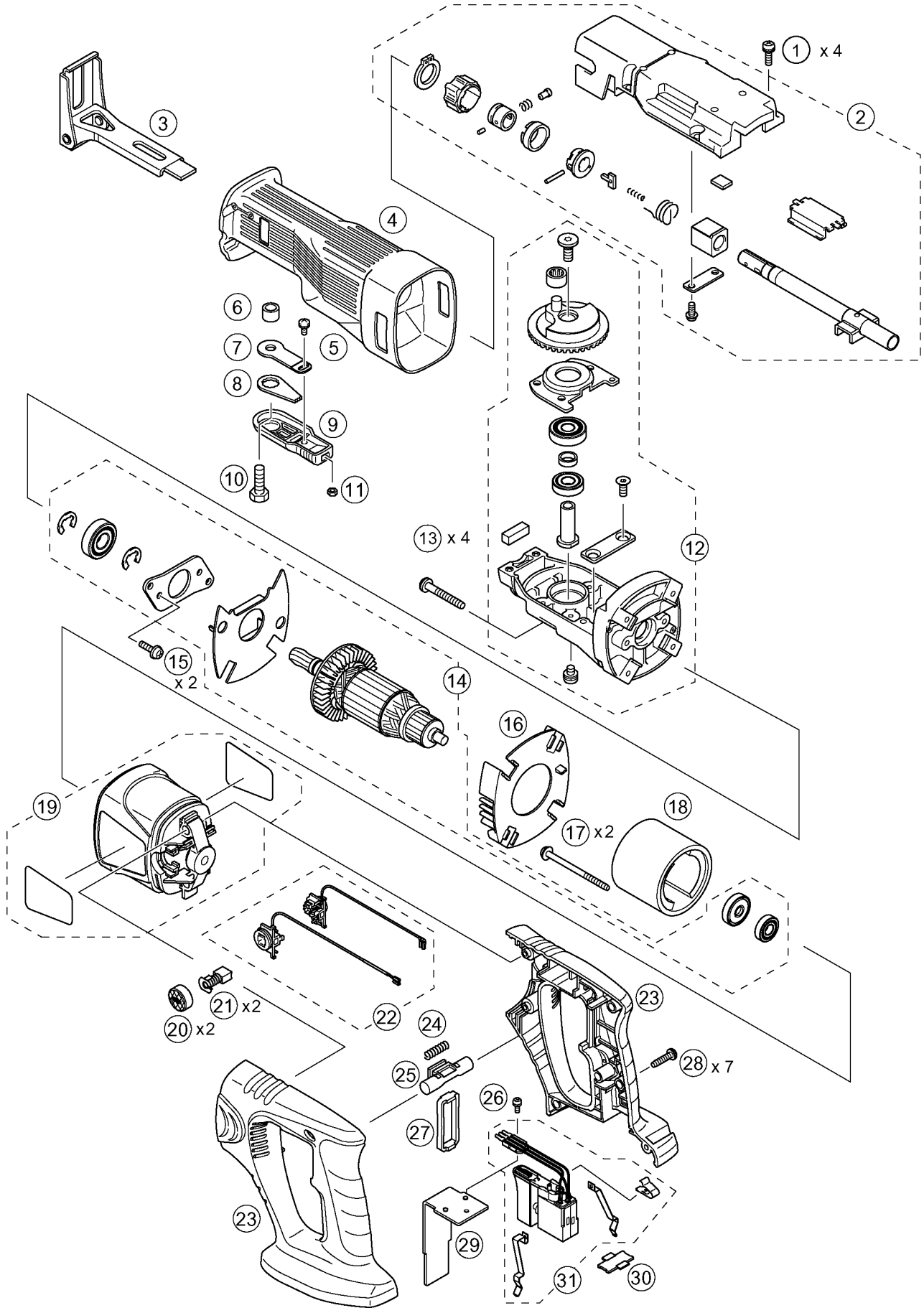

6 REPLACEMENT PARTS LIST

NOTE:

*B=only available as set

*C=available individually

Ref.No.	Part No.	Part Name & Description	Remarks		Per Unit
1	WEY3544K6708	SCREW	*C	M5*18	4
2	WEY3544S1168	BLADE CLAMP BLOCK			1
3	WEY3544K0228	SHOE			1
4	WEY3544H3648	INSULATED RUBBER BOOT			1
5	WEY3544K6278	SCREW		M4*10	1
6	WEY3544K0478	SLEEVE			1
7	WEY3544K1168	INNER PLATE			1
8	WEY3544K1178	LOCK PLATE			1
9	WEY3544K1558	SHOE LOCK LEVER			1
10	WEY3544K6398	HEXAGONAL HEAD BOLT		M8*25	1
11	WEY3544K6428	HEXAGONAL NUT		M4	1
12	WEY3544S1768	GEAR CASE BLOCK			1
13	WEY3544L9388	TAPPING SCREW	*C	5*35	4
14	WEY3544L4628	MOTOR ROTOR ASSEMBLY			1
15	WEY3544L6218	SCREW	*C	M4*12	2
16	WEY3544L0478	BAFFLE PLATE			1
17	WEY3544L9668	TAPPING SCREW	*C	4*60	2
18	WEY3544L1188	STATOR			1
19	WEY3544K0538	MOTOR HOUSING			1
20	WEY3544K0558	HOLDER CAP	*B	(2PCS/PK)	2
21	WEY3544L4638	CARBON BRUSH	*B	(2PCS/PK)	2
22	WEY3544L4368	BRUSH HOLDER			1ST
23	WEY3544K3078	HOUSING AB SET			1
24	WEY3544L0178	SPRING			1
25	WEY3544Y3568	RELEASE LEVER			1
26	WEY3544L6208	SCREW		M3*8	1
27	WEY3544L0088	SWITCH FRAME			1
28	WEY3544K9218	TAPPING SCREW	*C	4*18	7
29	WEY3544L2568	HEAT SINK			1
30	WEY3544L0208	HOLDER PLATE			1
31	WEY3544Y2008	SWITCH			1
-	WEY3544K8108	OPERATING INSTRUCTIONS			1

**Battery Pack, and Tool Case are available as an optional accessory.

See the nearest sales dealer for details.

***For replacement parts of charger, see the charger service manual.

Charger complete set is available as an optional accessory. See the nearest sales dealer for details.