



**Panasonic Manufacturing (Xiamen) Co., Ltd.**

<https://www.panasonic.com>

© Panasonic Manufacturing (Xiamen) Co., Ltd. 2023



Printed in China

JZ50M166  
MX0223L0

SK



# Panasonic®

## Operating Instructions

### 使用说明书

## Arahan Penggunaan

### Juicer (Household Use)

### 榨汁机 (家庭用)

## Pemerah Jus (Kegunaan isi rumah)

English

中文(简体)

Melayu

Model No.  
No. Model.  
型号

**MJ-CB600**  
**MJ-CB100**

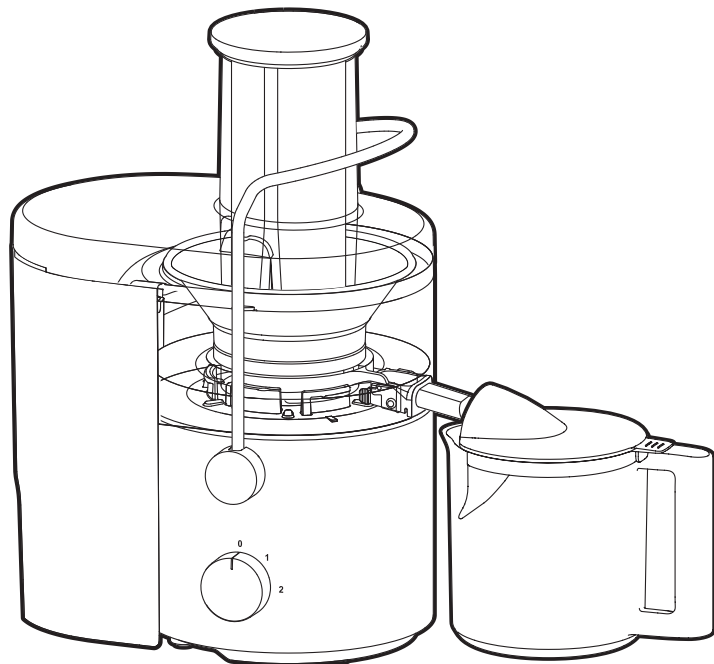



Thank you for purchasing this Panasonic product.

- Please read these instructions carefully to use the product correctly and safely.
- Before using this product **please give your special attention to “Safety Precautions” and “Important Information” (P. EN2 - EN4).**
- Please keep this Operating Instructions for future use.
- Panasonic will not accept any liability if the appliance is subject to improper use, failure to comply with these instructions.

## Contents

Safety Precautions .....	EN2
Important Information .....	EN4
Parts Names and Instructions.....	EN5
Overload and Overheating Protection .....	EN5
Before Use.....	EN6
How to Use.....	EN6
After Use.....	EN7
Troubleshooting .....	EN8
Specifications .....	EN8

## Safety Precautions

Please make sure to follow these instructions.



In order to prevent accidents or injuries to the user, other people, and damage to property, please follow the instructions below.

■ The following signals indicate the degree of harm and damage when the product is misused.

 **WARNING:** Indicates potential hazard that could result in serious injury or death.

 **CAUTION:** Indicates potential hazard that could result in minor injury or property damage.

■ The symbols are classified and explained as follows.

 This symbol indicates prohibition.  This symbol indicates requirement that must be followed.

### WARNING

To prevent electric shock, fire caused by short circuit, smoke, scald or injury.

-  ● **Do not allow infants and children to play with packaging material.**  
(It may cause suffocation.)
- **Do not disassemble, repair or modify this appliance.**  
→ Contact Panasonic Service Centre for inspection or repair.
- **Do not damage the power cord or power plug.**  
Following actions are strictly prohibited:  
Modifying, touching on or placing near heating elements or hot surfaces, bending, twisting, pulling, hanging/pulling over sharp edges, putting heavy objects on top, bundling the power cord or carrying the appliance by the power cord.
- **Do not plug or unplug the power plug with wet hands.**



## WARNING

- **Do not use the appliance if the power cord or power plug is damaged or the power plug is loosely connected to the outlet.**
  - If the power cord is damaged, it must be replaced by the manufacturer, its service centre or similarly qualified person in order to avoid a hazard.
  - Insert the power plug firmly.
- **Do not immerse the motor housing, power cord or power plug in water, or splash it with water and / or any liquid.**
- **Do not remove pulp container when the appliance is operating.**
- **Do not use the appliance if the spinner (rotating sieve) and the container cover (protection cover) is damaged or has visible cracks.**
  
- **This appliance is not intended for use by persons (including children) with reduced physical, sensory or mental capabilities, or lack of experience and knowledge, unless they have been given supervision or instruction concerning use of the appliance by a person responsible for their safety.**

Children should be supervised to ensure that they do not play with the appliance.
- **Keep the appliance and its power cord out of reach of children.**
- **Dust off the power plug regularly.**
  - Unplug the power plug, and wipe with a dry cloth.
- **Discontinue using the appliance immediately and unplug in the unlikely event that this appliance stops working properly.**

e.g. for abnormal occurrences or breaking down

  - The power plug or the power cord become abnormally hot.
  - The appliance power fails.
  - The motor housing is deformed, has visible damage or is abnormally hot.
  - There is crack on the container and other parts.
  - There is an unpleasant smell.
  - There is abnormal turning noise while in use.
  - There is another abnormality or failure.
  - Contact Panasonic Service Centre for inspection or repair.
- **Make sure the voltage indicated on the label of the appliance is the same as your local supply.**

Also avoid plugging other devices into the same outlet to prevent electric overheating. However, if you are connecting a number of power plugs, make sure the total wattage does not exceed the rated wattage of the outlet.



## CAUTION

To prevent electric leakage, electric shock, fire caused by short circuit, scald, injury or property damage.



- **Do not use the appliance on the following places.**
  - On uneven surfaces, on carpets or tablecloths etc.
  - Place where it may be splashed with water or near a heat source.
  - Near any open water such as bathtubs, sinks, or other containers.
  - Near a wall or furniture.
  - Place the appliance on a firm, dry, clean flat worktop.
- **Never use hot water (over 60 °C) for cleaning purpose or fire to dry the appliance.**



## Safety Precautions

Please make sure to follow these instructions.

### CAUTION

-  ● Do not open the cover and put your fingers or utensils such as spoon or fork into the feeding tube while the appliance is operating. (Use the food pusher or another piece of fruit or vegetable to push it down.)
  - Do not assemble the spinner when there is food residue left around the container unit.
  - Do not replace any parts of the appliance with non-genuine spare parts.
  - Do not carry the appliance by holding the power cord, feeding tube or container unit. When carrying the appliance, be sure to hold the motor housing with both hands.
  - Do not insert any object in the gaps of the appliance.
  - Do not use prohibited ingredients as stated in this instructions. (P. EN6)
- 
-  ● Unplug the plug when the appliance is not in use.
  - Make sure to hold the power plug when unplugging it. Never pull on the power cord.
  - Beware not to trip over or get caught in the power cord while in use.
  - In order to avoid a hazard due to inadvertent resetting of the thermal cut-out, this appliance must not be supplied through an external switching device, such as a timer, or connected to a circuit that is regularly switched on and off by the utility.
  - Care shall be taken when handling the spinner and during cleaning. Do not clean the spinner by bare hand.
  - Always disconnect the appliance from the supply if it is left unattended and before assembling, disassembling, moving or cleaning.
  - Switch off the appliance and disconnect from supply before changing attachments or approaching parts that move in use.
  - Ensure to operate and rest the appliance as stated on specification table. (P. EN8 "Specifications")
  - Ensure to clean the appliance especially surfaces in contact with food after use. (P. EN7 "After Use")
  - This product is intended for household use only.

## Important Information

- Do not use the appliance outdoors.
- Do not use the appliance for commercial purpose.
- Do not place the juice cup on any heat sources or in a microwave.
- Do not drop the appliance or attachments to avoid damaging it.
- Do not wrap the power cord around the motor housing.
- Make sure the parts or attachments are set firmly before use.
- Do not operate the appliance without ingredients.



# Parts Names and Instructions

## Juicer

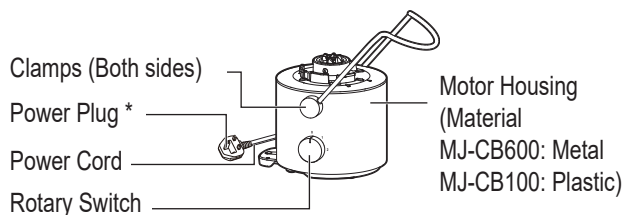
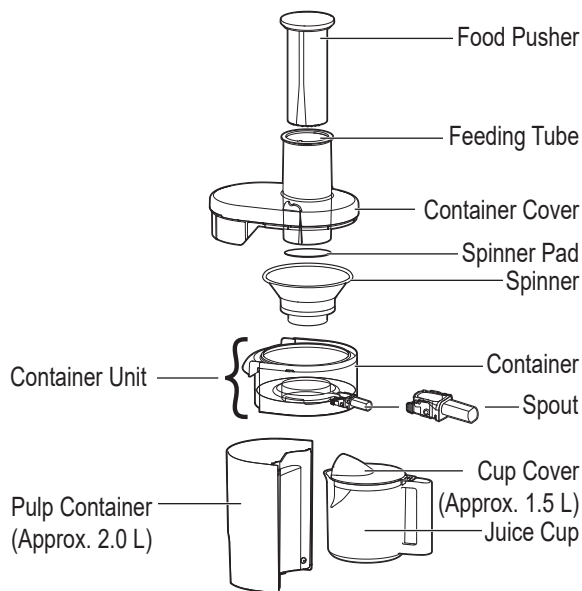

## Accessory

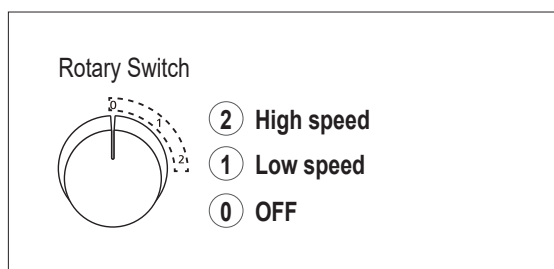
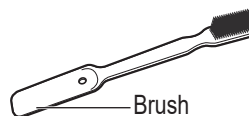

\* The shape of the power plug may be different from illustration.

• Illustrations of product in this instructions are exemplified by MJ-CB100.

English

# Overload and Overheating Protection

In case of overload and overheating, the protection device is triggered to stop operation and it is not abnormal. After rotation stops, follow the below steps:

- Do not use the appliance repeatedly without any countermeasure.

- 1** Turn the rotary switch to “0” position, unplug the appliance.
- 2** Remove attachment from motor housing. Remove accumulated food residue from the spinner/container cover.
  - Remove the prohibited ingredient if used.
- 3** Reset the attachment, then start again. (P. EN6)

If the appliance still does not operate after performing the above, overheating protection has been activated.

Turn the rotary switch to “0” position, unplug and rest the appliance for about 15 minutes or more (until motor housing returns to a normal temperature) to release overheating protection before using again. (If appliance still does not operate, contact Panasonic Service Centre for inspection or repair.)



# Before Use

Clean all detachable parts before using the appliance for the first time or when you have not used it for a while, and then assemble them securely. (P. EN6 “How to Use” and P. EN7 “After Use” )

## Handling Precautions

- Ingredients that are not recommended:  
Soft fruits that produce puree and can clog the spinner – e.g. bananas, peaches, apricots etc.  
Low juice ingredients which can block the product – e.g. fresh basil leaf for etc.
- Please remove hard seeds and stones from fruit before juicing such as guava etc. Hard seeds that are difficult to remove from such as pomegranate is prohibited for juicing.
- During initial usage, the appliances might have some unpleasant smell (slight burn smell) but this condition is normal.
- Some ingredients may produce a lot of pulps accumulate to the container cover that cause operation stop.( Overload and Overheating Protection: refer to page EN5)
- Make sure all parts are correctly mounted before you switch on the appliance.
- Please use the juice cup with the cup cover to avoid juice splashing. Make sure to align the juice jug opening to the spout when juicing.
- Speed 2 is suitable for hard type fruits e.g. apples, carrots etc. while speed 1 is suitable for softer type fruits e.g. watermelons.

## To Disassemble

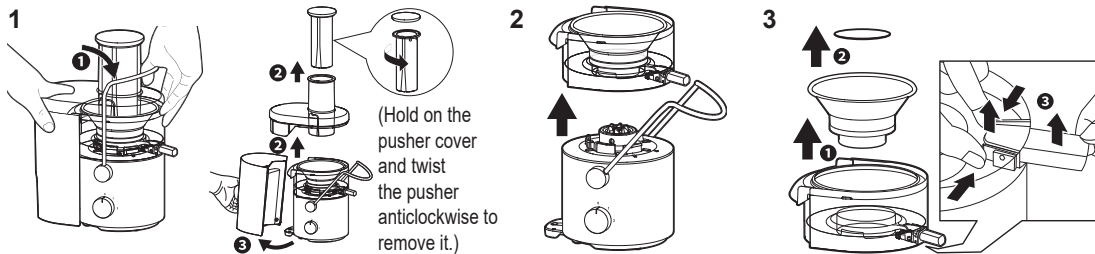

① Release the clamps.

② Lift up the food pusher and container cover.  
③ Detach the pulp container.

Lift up the container unit.

① Lift up the spinner.  
② Remove the spinner pad by turning the spinner upside down.  
③ Turn the container unit upside down and remove the spout from the container.

## How to Use

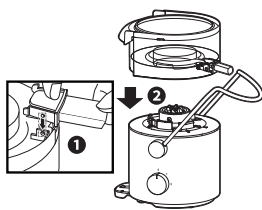

**1 Turn the container upside down and assemble the spout. Place the container unit onto the motor housing.**

- Make sure the spout and the clamps are positioned the same as illustrated.
- Make sure the container unit sits properly on the motor housing.

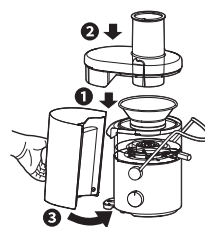

**2**

- ① Place the spinner in the container unit and fix it into position.
- ② Place the container cover onto the container unit.
- ③ Attach the pulp container and make sure it is fully aligned with the body.

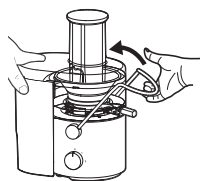

**3 Push the clamps as shown until a locking sound is heard.**

- If the clamps are not clamped correctly, the motor will not operate.

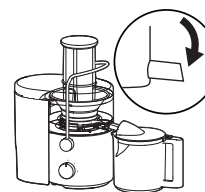

**4 Place the juice cup as shown.**

- Make sure the spout is in the downward position when juicing.

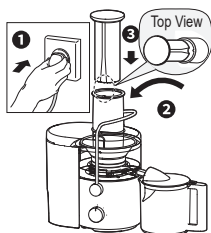

**5**

- ① Plug in and switch on.
- ② Insert the ingredients one by one and push them slowly into the feeding tube using the food pusher.
- ③ Align the food pusher into the feeding tube as illustrated.

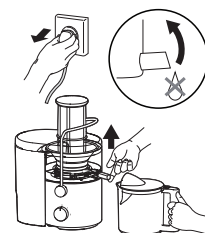

**6 After use, switch off and unplug.**

- While removing the juice cup, ensure the spout is pulled up to prevent juice from dripping.
- Ensure the spinner is fully stopped before release the clamps.
- Some pulp might be hard to collect in the pulp container and stick on the container cover depending on the ingredients and amount.











# After Use

- Before detaching parts, make sure the motor has stopped completely, then disconnect the plug from the outlet.
- Clean the parts thoroughly after every use. Keep all parts clean and dry always.
- Do not use benzine, thinner, bleach, alcohol, nylon face of sponge, metal brushes or polish powder etc.
- Some discolouration of the plastic parts may occur upon usage. Even if the parts are washed with a sponge, the discolouration can not be completely removed, but it does not affect usage. If you clean the parts as soon as possible after usage, it can be removed relatively well.
- When cleaning the parts in a dishwasher, do not put heavy objects on top of the parts.

English

## Cleaning

									
Running Water	✓	✓	✓	✓	✓	✓	✓	✓	✗
Dishwasher	✓	✓	✓	✓	✓	✓	✓	✗	✗
Well-wrung Damp Cloth	✓	✓	✓	✓	✓	✓	✓	✗	✓
Brush	✗	✗	✗	✗	✗	✗	✗	✓	✗
Scouring Pad	✗	✗	✗	✗	✗	✗	✗	✗	✗
Soft Sponge	✓	✓	✓	✓	✓	✓	✓	✗	✓
Note	Wash each part in cold or lukewarm water with a soft sponge. Rinse and dry thoroughly before storing.							Wash carefully with a brush under running water.	Wipe off any dirt or stains with a clean damp cloth.

## Storing

### Power Plug and Power Cord

- 1) Turn over the motor housing and wind the cord two turns as illustrated.

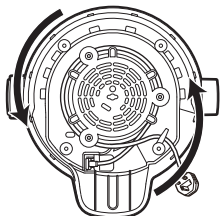

- 2) Insert the cord into the power cord clamp to fit the cord in position.

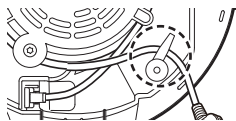

- 1) Turn over the juice cup and place it on the feeding tube.
- 2) Keep the cup cover inside the pulp container.

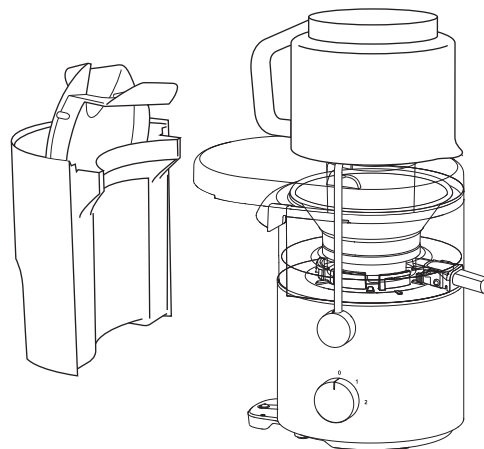





# Troubleshooting

Before calling for service, please check through this section.

Problem	Cause and Action
The appliance does not turn on.	<ul style="list-style-type: none"> <li>● <b>The container is not set properly.</b> → Assemble it tightly. (P. EN6)</li> <li>● <b>The protection device of overload or overheating is activated.</b> → Refer to "Overload and Overheating Protection" for inspection. (P. EN5)</li> <li>● <b>The power plug is disconnected.</b> → Insert the power plug into outlet firmly.</li> </ul>
Rotation stops abruptly.	<ul style="list-style-type: none"> <li>● <b>The protection device of overload or overheating is activated.</b> → Refer to "Overload and Overheating Protection" for inspection. (P. EN5)</li> </ul>
There is abnormal noise or vibration increases.	<ul style="list-style-type: none"> <li>● <b>Too much ingredients.</b> → Reduce ingredient amount.</li> <li>● <b>The container unit is not assembled tightly.</b> → Assemble it tightly. (P. EN6)</li> </ul>

# Specifications

<b>Power Supply</b>	220 - 240 V ~ 50 - 60 Hz
<b>Power Consumption</b>	270 - 320 W
<b>Operation Rating</b>	Continuous (Repetition 2 min ON, then 2 min OFF)
<b>Dimension (Approx.) (W x D x H)</b>	208 x 304 x 386 (mm)
<b>Weight (Approx.)</b>	3.6 kg
<b>Capacity (Approx.)</b>	Working Capacity: Juice Cup: 1.5 L; Pulp Container: 2.0 L



非常感谢您购买此Panasonic的产品。

- 请仔细阅读本使用说明书，以确保正确安全使用本产品。
- **使用前请务必仔细阅读“安全注意事项”和“重要信息”（第 SC2-SC4页）。**
- 保用证请与本使用说明书一起妥善保管。
- 因对本产品的使用不当或未能遵循相关说明，Panasonic 将不承担任何责任。

## 目录

安全注意事项.....	SC2
重要信息 .....	SC4
部件名称及说明 .....	SC5
过负载和过热保护 .....	SC5
使用前 .....	SC6
使用方法 .....	SC6
使用后 .....	SC7
故障诊断.....	SC8
规格 .....	SC8

## 安全注意事项

请务必遵守以下说明。

为了减少人身伤害、触电及火灾的风险，请务必遵守下面说明的事项。

■ 以下标志表示因错误使用本产品而造成伤害和损失的程度。



**警告：**表示有可能导致重伤或死亡的潜在危险。



**注意：**表示有可能导致人身伤害或财产损失的潜在危险。

■ 符号分类和说明如下。



表示禁止事项。



表示必须遵循的事项。



**警告**

为了防止出现触电、因短路引起的火灾、出烟、烫伤或受伤的危险。



● **切勿让婴儿或儿童玩耍包装材料。**

(可能会导致窒息)

● **绝对不可自行拆解、修理或改装本产品。**

→ 请与服务中心联系进行检查或维修。

● **请勿损坏电源线或电源插头。**

严格禁止以下行为：

加工、触碰到高温表面或将其放置在发热品附近，强行弯曲、扭转、拉扯、悬挂在锋利的边沿，或从锋利边沿拉过，在电源线上放置重物，捆扎电源线以及以拉住电源线的方式提起本产品。



● **请勿用潮湿的手插拔电源插头。**



## 安全注意事项

请务必遵守以下说明。

### 警告

-  ● **电源线或电源插头损坏或插座松动时，切勿使用本产品**
  - 如果电源线损坏，为了避免危险，必须由制造商、其维修部或类似部门的专业人员更换。
  - 电源插头必须完全插入插座内。
- **请勿将马达机座及其电源线或电源插头浸泡在水中，或被水及其他液体溅到。**
- **请勿在本产品运行时取出果肉容器。**
- **若旋转篮（旋转筛）和容器盖（保护盖）损坏或有可见裂纹，请勿使用本产品。**
  
-  ● **本产品不打算由儿童或有体力、感官或精神缺陷的人或缺乏经验知识的人使用，除非有负责他们安全的人对他们进行产品使用有关的监督和指导。**
  - 应照看好儿童，确保他们不玩耍本产品。**
- **请务必确保儿童远离本产品及其电源线。**
- **请定期清除电源插头上的灰尘**
  - 拔下电源插头，并用干布进行擦拭。
- **若本产品发生运转异常时，请立即停止使用本产品，并拔出电源插头。**

异常或故障示例：

  - 电源插头和电源线异常发热。
  - 本产品无法通电。
  - 马达机座变形、有明显损坏或者电源线异常。
  - 容器或其他部件有裂纹。
  - 飘出异味。
  - 使用过程中有异常的转动声。
  - 出现其他异常或故障。

→ 请与松下服务中心联系以进行检查或维修。
- **请务必确保本产品的标签上指示的电压与当地电源电压一致。**

还应避免在同一电源插座中插入其他设备，以免电路过热。  
但如果连接多个电源插头应确保总功率不超过电源插座的额定功率。

### 注意

为了防止出现漏电、触电、因短路造成的火灾、烫伤、受伤或财产损失的危险。

-  ● **请勿在下列场所使用本产品。**
  - 在不平整的表面、地毯或铺有桌布上等场所。
  - 可能会被溅到水的地方或热源附近。
  - 靠近水槽等或任何开放式水源附近。
  - 靠近墙壁或家具。

→ 请将本产品放置在平稳、干燥、干净、平坦的桌面上。
- **请勿使用热水（超过 60 °C）清洁或使用火烘干本产品。**
- **本产品正在运转时，请勿打开盖子或将手指或汤匙、叉子等器具放入投料口中。**

（请使用压料棒或用另一个水果或蔬菜把它推入。）

SC3



## ⚠ 注意

- 当容器周围有食物残渣时，请勿安装旋转篮。
  - 请勿使用非原装部件更换本产品上的任何部件。
  - 请勿以握住电源线、投料口或容器组件的方式拿取本产品。搬动本产品时，确保用双手握紧马达机座。
  - 请勿在本产品的缝隙里塞入任何物品。
  - 请勿使用本说明书内所记载的禁止食材。（第 SC6 页）
- 
- 不使用本产品时请拔出电源插头。
  - 务必以握拿电源插头的方式拔出电源插头。禁止用力拉扯电源线。
  - 使用时，请小心不要踩踏电源线或被其绊倒。
  - 为避免因温度断路器的误复归而发生危险，本产品不得经由外部开关装置供电。（例：计时器，或连接到定期切换“开”、“关”功能的电路。）
  - 在处理旋转篮和清洁时，请一定小心。请勿徒手清理旋转篮。
  - 如无人看管、或在组装、拆卸、移动、清洁前，请先断开产品电源。
  - 更换配件或接触任何在使用中会移动的零件前，请先关闭本产品并断开电源。
  - 请务必按照规格表的要求操作和关闭本产品。（第 SC8 页“规格”）
  - 请确保每次使用后清洁本产品，尤其是与食物接触的表面。（第 SC7 页“使用后”）
  - 本产品仅供家庭使用。

## 重要信息

- 请勿在室外使用本产品。
- 请勿将本产品用于商业用途。
- 请勿将果汁杯放置于任何热源上或放入微波炉中。
- 请勿使本产品或配件跌落，以免造成损坏。
- 请勿将电源线缠绕在马达机座上。
- 使用前请确保各部件及配件组装好。
- 请勿让本产品空转。



## 部件名称及说明

### 榨汁机

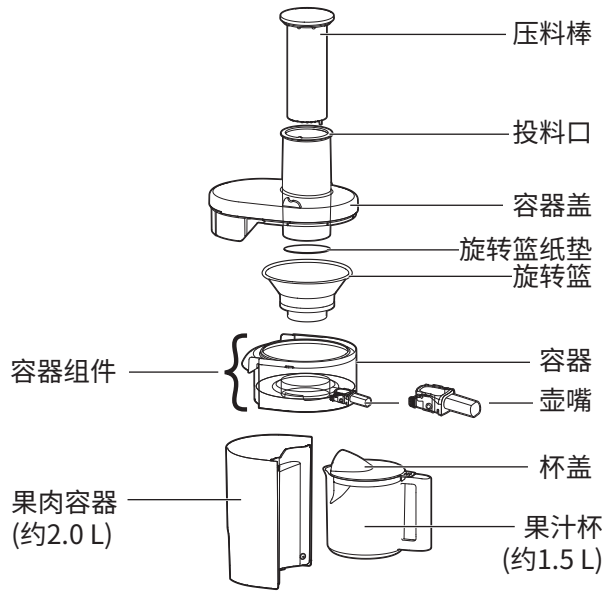

### 配件



#### 旋转开关

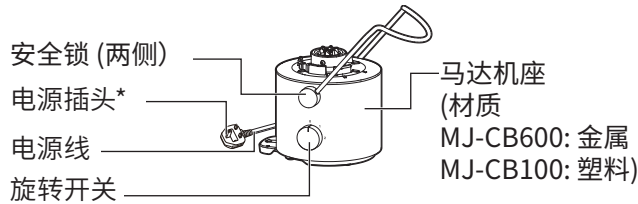
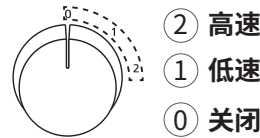

- \* 插头的形状可能和图示不同。  
● 本说明书中图示以 MJ-CB100 为例。

## 过负载和过热保护

当过负载或过热时，保护装置将被启动以停止本产品运转，这并非故障。运转停止后，请按照以下步骤进行操作。

- 请勿在未加处理的情况下反复使用本产品。

**1** 将旋转开关旋转到“0”档位置，拔除电源插头。

**2** 将配件从马达机座上取下。清除掉旋转篮及容器盖上堆积的食物残渣。

- 如果放入了禁止材料，请取出。

**3** 重新组装配件，然后再次开始。(第SC6页)

如果按照上述操作后本产品仍无法正常使用，则是过热保护被启动。

再次使用前，将旋转开关旋转到“0”档，拔除电源插头并让本产品休息约 15 分钟或以上（直至马达机座恢复至正常温度）以解除过热保护。

(若本产品还无法正常使用，请与服务中心联系进行检查或维修。)

# 使用前

首次使用前或一段时间未使用时,请清洁所有可拆卸部件,然后将其牢固安装。(第 SC6 页“使用方法”和第 SC7 页“使用后”)

## 注意事项

- 禁止食材:  
会产生果泥的软水果会堵塞旋转篮,如香蕉、桃、杏等。  
黏性强的食品,如新鲜罗勒叶。  
可能会导致产品出现故障的坚硬材料,例如甘蔗、椰子等。
- 榨果汁前,请把水果里的坚硬种子和核清除,例如番石榴等水果。  
具有难以去除坚硬种子的水果,如石榴将禁止榨汁。
- 在最初使用本产品时,可能会产生一些气味(轻微燃烧的味道)在这种情况下是正常的。
- 有些食材的成分可能会产生大量的果浆渣累积在容器盖上,这样会导致操作停止。  
(过载和过热保护:参照第 SC5 页)
- 操作本产品前,请确保所有配件都已经正确安装。
- 请使用果汁杯并盖上杯盖以避免蔬果汁飞溅。榨汁时,确保果汁杯入口和壶嘴对齐。
- 速度 2 适用于坚硬的水果,例如苹果、胡萝卜等,而速度 1 适用于较软的水果,例如西瓜。

## 拆解方法

- 

① 松开安全锁。
- 

② 取出压料棒和容器盖。  
③ 取下果肉容器。

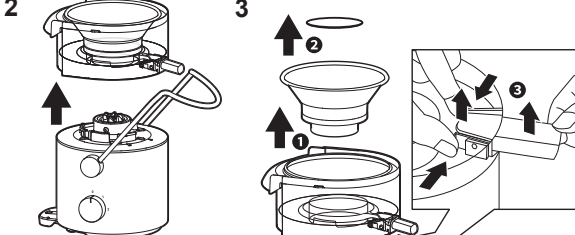
(握住压料棒盖并逆时针转动压料棒将其取下。)
- 

取出容器组件。

① 取出旋转篮。  
② 倒置旋转篮取出旋转篮纸垫。  
③ 倒置容器组件然后从容器上拆下壶嘴。

## 使用方法

- 

1 将容器倒置后安装好壶嘴。将容器组件放到马达机座上。

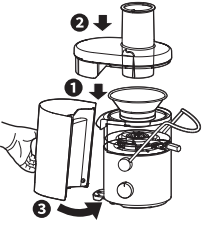
  - 确保壶嘴和安全锁的位置与图示相同。
  - 确保容器组件正确安装到马达机座上。
- 

2 ① 请将旋转篮放置在容器组件的正确位置上,并且安装到位。  
② 请将容器盖安装到容器组件上面。  
③ 安装果肉容器并确保其与机身完全对齐。
- 

3 如图所示推动安全锁,直到听见锁定声。

  - 如果安全锁没有完全锁上,马达无法运转。
- 

4 请如图所示放置果汁杯。

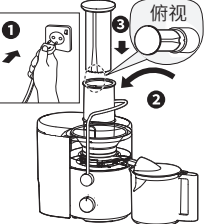
  - 榨汁时,确保壶嘴处于朝下的位置。
- 

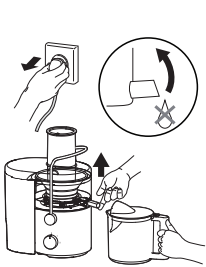
5 ① 插入电源插头并打开开关。  
② 将食材一个接一个的放入投料口并用压料棒慢慢推入。  
③ 如图所示将压料棒和投料口对齐推入。
- 



6 使用后,关闭并拔下电源插头。

  - 取出果汁杯的时候,确保将壶嘴拉起以防止果汁滴落。
  - 在松开安全锁之前请确保旋转篮完全停止转动。
  - 根据不同的食材与份量,有些果渣可能很难被果肉容器收集并黏在容器盖上。

## 使用后

- 拆解配件前, 确保本产品完全停止, 然后从电源插座上拔出电源插头。
- 每次使用后, 请彻底清洁部件。并保持所有的部件干净且干燥。
- 请勿使用挥发性溶剂、稀释剂、漂白剂、酒精、尼龙面海绵、金属刷或抛光粉等。
- 使用时塑料部件可能会变色, 即使用海绵清洗也无法完全去除变色现象, 但这对使用上并不造成任何問題。产品使用后请盡快进行清潔, 較能去除色素。
- 使用洗碗機进行部件清洗時, 請勿將重物放置在各部件的上方。

## 清洁

										
流水	✓	✓	✓	✓	✓	✓	✓	✓	✗	
洗碗机	✓	✓	✓	✓	✓	✓	✓	✗	✗	
拧干的湿布	✓	✓	✓	✓	✓	✓	✓	✗	✓	
刷子	✗	✗	✗	✗	✗	✗	✗	✓	✗	
百洁布	✗	✗	✗	✗	✗	✗	✗	✗	✗	
海绵	✓	✓	✓	✓	✓	✓	✓	✗	✓	
提示	使用柔软的海绵在冷水或温水中清洗每一个部件, 收纳前请冲洗干净并完全晾干。							使用刷子在流水下仔细清洗。		使用柔软 的拧干的湿布 擦拭掉任何 污垢和污 渍。

## 收纳

### 电源插头和电源线

- 1) 将马达机座翻转过来, 如图所示将电源线缠绕两圈。

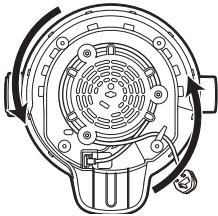

- 2) 将电源线插入电源线夹以将电源线固定到位。

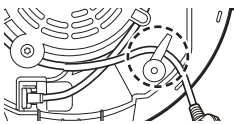

- 1) 将果汁杯翻转过来扣在投料口上。
- 2) 将杯盖放入果肉容器内。

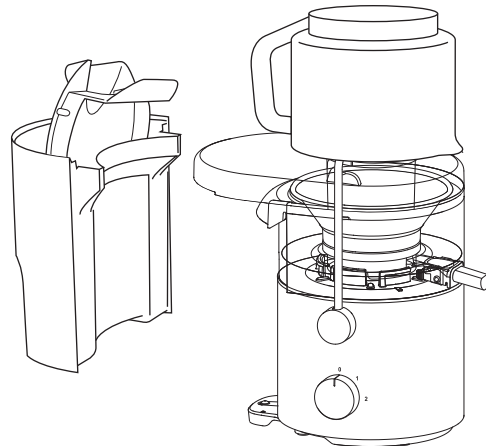

## 故障诊断

拨打客服电话或安排维修之前，请先检查下列事项。

问题	原因和解决方法
无法启动本产品	<ul style="list-style-type: none"><li>● 容器未正确放置。 → 组装到位 (第6页)</li><li>● 过载或过热保护被启动。 → 请参照“过载和过热保护”进行检查。(第SC5页)</li><li>● 电源插头脱落 → 将电源插头完全插入电源插座内。</li></ul>
突然停止运转	<ul style="list-style-type: none"><li>● 过载或过热保护被启动。 → 请参照“过载和过热保护”进行检查。(第SC5页)</li></ul>
有异音或震动较大	<ul style="list-style-type: none"><li>● 食材放入太多。 → 减少食材份量</li><li>● 容器组组装的不牢固。 → 组装到位。(第6页)</li></ul>

中文(简体)

## 规格

电源	220 - 240 V ~ 50 - 60 Hz
额定功率	270 - 320 W
额定时间	持续运转 (以运转 2 分钟, 休息 2 分钟方式重复操作)
尺寸 (长 x 宽 x 高) (约)	208 x 304 x 386 (mm)
重量 (约)	3.6 kg
容量 (约)	工作容量: 果汁杯: 1.5 L; 果肉容器: 2.0 L

SC8





Terima kasih kerana membeli produk Panasonic ini.

- Sila baca arahan ini dengan teliti untuk menggunakan produk dengan betul dan selamat.
- Sebelum menggunakan produk ini, **sila berikan perhatian khas kepada “Langkah-Langkah Keselamatan” dan “Maklumat Penting” (P. ML2 - ML4).**
- Sila simpan Arahan Penggunaan ini untuk kegunaan masa hadapan.
- Panasonic tidak akan menerima sebarang liabiliti jika perkakas digunakan secara tidak wajar, atau gagal mematuhi arahan ini.

## Kandungan

Langkah-Langkah Keselamatan.....	ML2
Maklumat Penting.....	ML4
Nama Bahagian dan Arahan.....	ML5
Perlindungan Beban Melampau dan Kepanasan Melampau .....	ML5
Sebelum Penggunaan .....	ML6
Cara Menggunakan .....	ML6
Selepas Penggunaan .....	ML7
Penyelesaian Masalah.....	ML8
Spesifikasi.....	ML8

## Langkah-Langkah Keselamatan Sila mematuhi arahan-arahan berikut.

Bagi mencegah kemalangan atau kecederaan kepada pengguna, orang lain dan kemusnahan harta benda, sila ikut arahan seperti di bawah.

- Isyarat berikut menunjukkan tahap bahaya dan kerosakan disebabkan oleh pengendalian yang salah.

 **AMARAN:** Menunjukkan potensi bahaya yang boleh mengakibatkan kecederaan serius atau kematian.

 **PERHATIAN:** Menunjukkan potensi bahaya yang boleh mengakibatkan kecederaan kecil atau kerosakan harta benda.

- Lambang diklasifikasi dan diterangkan seperti berikut.

 Simbol ini menunjukkan larangan.

 Simbol ini menunjukkan keperluan yang perlu dipatuhi.

### AMARAN

Bagi mencegah renjatan elektrik, kebakaran yang disebabkan oleh litar pintas, asap, melecur atau kecederaan.

-  ● **Jangan biarkan bayi dan kanak-kanak bermain dengan bahan pembungkusan.** (Ia boleh menyebabkan kesesakan nafas.)
- **Jangan menceraikan, membaiki atau mengubah suai perkakas ini.**  
→ Rujuk tempat perkakas dibeli atau pusat servis Panasonic.
- **Jangan rosakkan tali kord atau palam kuasa.**  
Tindakan berikut adalah dilarang:  
Merosak, mengubahsuai atau meletaknya berdekatan dengan elemen pemanasan; membengkok, memutar, menarik dengan kuat, menarik ke atas tepi tajam, meletakkan objek berat di atasnya, mengikat tali kord dan membawa perkakas dengan memegang tali kord.
- **Jangan pasang palam atau cabut palam kuasa menggunakan tangan yang basah.**

ML2



## AMARAN



- **Jangan gunakan perkakas jika tali kord atau palam kuasa rosak atau palam kuasa disambungkan dengan longgar ke soket sesalur rumah.**
  - Jika tali kord sudah rosak, ia mesti digantikan oleh pengeluar, ejen perkhidmatan yang berkenaan, atau orang yang berkelayakan untuk mengelakkan bahaya.
  - Pasangkan palam kuasa dengan kukuh.
- **Jangan rendamkan bahagian motor, kord dan palam kuasa dalam air atau simbahnya dengan air / apa-apa cecair.**
- **Jangan keluarkan bekas pulpa apabila perkakas sedang beroperasi.**
- **Jangan gunakan perkakas jika pemintal (ayak berputar), atau penutup bekas (penutup perlindungan) rosak atau mempunyai rekahan yang ketara.**



- **Perkakas ini tidak sepatutnya digunakan oleh orang (termasuk kanak-kanak) yang kekurangan keupayaan fizikal, deria atau mental, kekurangan pengalaman dan pengetahuan; kecuali mereka yang pernah diawasi atau diberi arahan mengenai penggunaan perkakas ini daripada orang yang bertanggungjawab terhadap keselamatan mereka.**  
**Kanak-kanak perlu diawasi untuk memastikan mereka tidak bermain dengan perkakas ini.**
- **Pastikan tali kord jauh dari capaian kanak-kanak.**
- **Bersihkan kotoran pada palam kuasa dengan kerap.**
  - Cabut palam kuasa, dan lap menggunakan kain kering.
- **Hentikan penggunaan perkakas dengan segera dan cabut palam jika perkakas tidak berfungsi dengan betul.**  
Contoh-contoh kejadian tidak normal atau rosak
  - Palam kuasa dan tali kord menjadi panas secara tidak normal.
  - Tali kord rosak atau kuasa perkakas gagal.
  - Bahagian motor berubah bentuk, mempunyai kerosakan yang kelihatan atau panas secara tidak normal.
  - Terdapat keretakan pada bekas atau bahagian-bahagian lain.
  - Terdapat bau yang tidak menyenangkan.
  - Terdapat bunyi putaran luar biasa semasa digunakan.
  - Terdapat ketidaknormalan atau kegagalan lain.
  - Rujuk tempat perkakas dibeli atau pusat servis Panasonic.
- **Pastikan voltan yang ditunjukkan pada label perkakas sama seperti bekalan tempatan anda.**  
Elakkan daripada memasang palam peranti lain pada soket sesalur rumah yang sama untuk mengelakkan elektrik yang berlebihan. Walau bagaimanapun, jika anda menyambung beberapa palam kuasa, pastikan jumlah watt tidak melebihi watt yang dikadarkan bagi soket sesalur rumah.



## PERHATIAN

Bagi mengelakkan kebocoran elektrik, kejutan elektrik, kebakaran yang disebabkan oleh litar pintas, melecun, kecederaan atau kerosakan harta benda.





- **Jangan gunakan perkakas di lokasi yang berikut.**
  - Pada permukaan yang tidak rata, atas permaidani atau alas meja dll.
  - Letakkan di tempat ia boleh dipercikikan dengan air atau berdekatan sumber haba.
  - Berdekatan mana-mana tempat air terbuka seperti tab mandi, sinki, atau bekas lain.
  - Berhampiran dinding atau perabot.
  - Letakkan perkakas di atas permukaan meja kerja yang rata, kering dan bersih.
- **Jangan sekali-kali menggunakan air panas (melebihi 60°C) untuk tujuan pembersihan atau menggunakan api untuk mengeringkan perkakas.**



## Langkah-Langkah Keselamatan Sila mematuhi arahan-arahan berikut.

### PERHATIAN

-  ● Jangan buka penutup dan masukkan jari atau perkakas anda seperti sudu atau garpu ke dalam bukaan penyalur bahan semasa perkakas sedang beroperasi. (Gunakan penolak bahan atau kepingan buah atau sayur lain untuk menolaknya.)
  - Jangan pasang pemintal apabila terdapat sisa makanan di sekeliling unit bekas.
  - Jangan ganti mana-mana bahagian perkakas dengan alat ganti yang tidak tulen.
  - Jangan bawa perkakas dengan memegang wayar kuasa, bukaan penyalur bahan atau unit bekas. Semasa membawa perkakas, pastikan anda memegang bahagian motor dengan kedua-dua tangan.
  - Jangan masukkan sebarang objek ke dalam celahan alat.
  - Jangan gunakan bahan terlarang seperti yang dinyatakan dalam arahan ini. (P. ML6)
- 
-  ● Cabut plag semasa perkakas tidak digunakan.
  - Pastikan untuk memegang palam kuasa apabila menanggalkan palam. Jangan sesekali menarik tali kord.
  - Berhati-hati supaya tidak tersandung atau terbelit oleh kord semasa menggunakannya.
  - Untuk mengelakkan bahaya yang disebabkan oleh penetapan semula pematian terma secara tidak sengaja, perkakas ini tidak boleh dibekalkan melalui peranti suis luar, seperti pemasa atau disambungkan pada litar yang selalu dihidupkan dan dimatikan oleh utiliti.
  - Sentiasa berhati-hati semasa mengendalikan pemintal dan semasa pembersihan. Jangan bersihkan pemintal dengan menggunakan tangan.
  - Sentiasa mencabut alat dari bekalan elektrik jika dibiarkan tanpa pengawasan dan sebelum memasang, membuka, bergerak atau membersihkan.
  - Matikan perkakas dan putus sambungan daripada bekalan kuasa sebelum menukar sambungan atau mendekati bahagian yang bergerak semasa digunakan.
  - Pastikan untuk mengoperasi dan merehatkan perkakas seperti yang dinyatakan pada jadual spesifikasi. (P. ML8 "Spesifikasi")
  - Pastikan untuk membersihkan perkakas terutamanya bahagian permukaan yang bersentuhan dengan makanan selepas penggunaan. (P. ML7 "Selepas Penggunaan")
  - Produk ini bertujuan untuk kegunaan isi rumah sahaja.

### Maklumat Penting

- Jangan gunakan perkakas di luar bangunan.
- Jangan gunakan perkakas untuk tujuan komersial.
- Jangan letakkan mangkuk pemerah jus pada sebarang sumber haba atau dalam ketuhar gelombang mikro.
- Jangan jatuhkan alat atau alat tambahan untuk mengelakkan daripada kerosakan.
- Jangan bungkus tali kord di sekitar bahagian motor.
- Pastikan bahagian atau alat tambahan dipasang dengan ketat sebelum digunakan.
- Jangan kendalikan perkakas tanpa bahan.



# Nama Bahagian dan Arahan

## Pemerah Jus

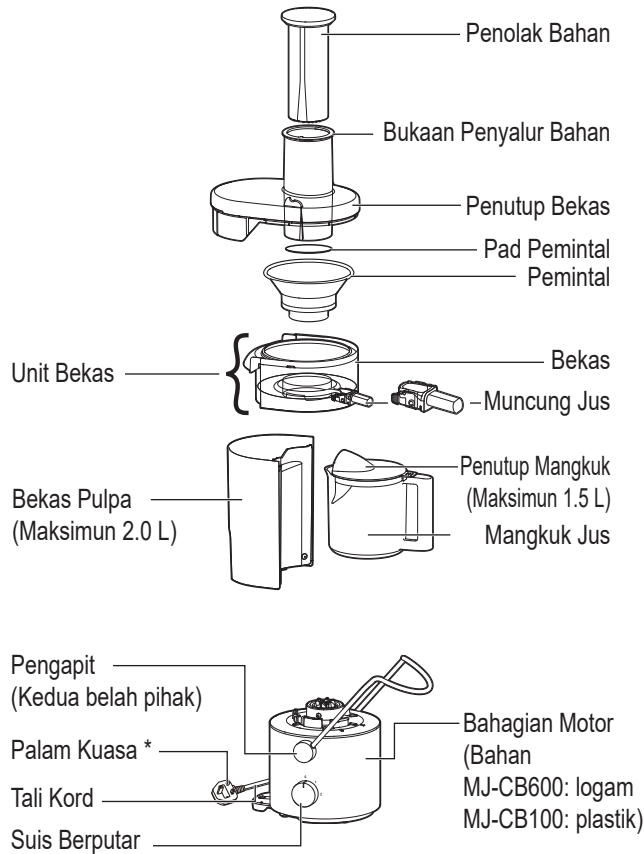

## Aksesori

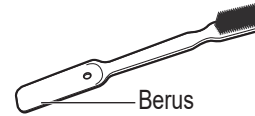

### Suis Berputar



- \* Bentuk palam mungkin berbeza daripada gambar.
- Ilustrasi produk dalam arahan ini diambil daripada MJ-CB100.

Melayu

## Perlindungan Beban Melampau dan Kepanasan Melampau

Dalam kes beban lampau dan kepanasan malampau, peranti perlindungan dicituskan untuk menghentikan operasi dan ia adalah sesuatu yang di luar kebiasaan.

Selepas putaran berhenti, sila ikuti langkah-langkah di bawah:

- Jangan gunakan perkakas berulang kali tanpa sebarang rehat.

**1** Putar tombol suis kepada "0", cabut plag perkakas.

**2** Tanggalkan sebarang lekapan dari bahagian motor. Keluarkan sisa makanan terkumpul dari pemintal/penutup bekas.

- Keluarkan bahan larangan jika digunakan.

**3** Menetapkan semula lampiran, kemudian bermula sekali lagi. (P. ML6)

Jika perkakas masih tidak beroperasi selepas melakukan perkara di atas, perlindungan kepanasan lampau telah diaktifkan.

Putar tombol suis kepada "0", cabut palam dan rehatkan perkakasan selama kira-kira 15 minit atau lebih (sehingga bahagian motor kembali ke suhu normal) untuk melepaskan perlindungan kepanasan melampau sebelum menggunakannya semula.

(Jika perkakas masih tidak beroperasi, sila hubungi Pusat Servis Panasonic untuk pemeriksaan atau pembaikan.)

ML5

# Sebelum Penggunaan

Bersihkan semua bahagian yang boleh ditanggalkan sebelum menggunakan perkakas untuk kali pertama atau apabila anda tidak menggunakannya untuk satu jangka masa yang lama dan kemudian pasangannya dengan ketat. (P. ML6 "Cara Menggunakan" dan P. ML7 "Selepas Penggunaan")

## Langkah berjaga-jaga semasa pengendalian

- Bahan-bahan yang tidak disyorkan:  
Bahan-bahan lembut yang menghasilkan puri dan boleh menyumbat pemintal – cth. pisang, pic, aprikot dll.  
Bahan yang kurang kandungan air – seperti daun selasih segar.
- Sila keluarkan biji yang keras dari buah sebelum dikisar seperti jambu batu dan lain-lain. Biji keras yang sukar dibuang seperti delima adalah dilarang untuk membuat jus.
- Semasa penggunaan awal, peralatan mungkin mempunyai sedikit bau yang tidak menyenangkan (sedikit bau terbakar) tetapi keadaan ini adalah normal.
- Sesetengah bahan mungkin menghasilkan banyak pulpa terkumpul pada penutup bekas yang menyebabkan operasi terhenti. (Perlindungan Beban Melampau dan Kepanasan Melampau: rujuk halaman ML5)
- Pastikan semua bahagian dipasang dengan betul sebelum anda menghidupkan perkakas.
- Sila gunakan mangkuk jus dengan penutup mangkuk untuk mengelakkan percikan jus. Pastikan untuk menyelaraskan bukaan mangkuk jus ke muncung jus semasa membuat jus.
- Kelajuan 2 sesuai untuk buah jenis keras cth. epal, lobak merah dan lain-lain manakala kelajuan 1 sesuai untuk buah jenis yang lebih lembut cth. buah tembikai.

## Untuk memisahkan

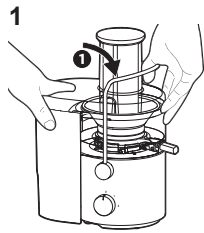

① Lepaskan pengapit.



② Angkat penolak bahan dan penutup bekas.  
③ Tanggalkan bekas pulpa.

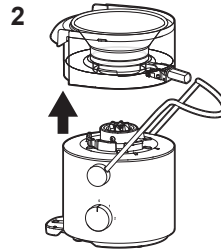

Angkat unit bekas.

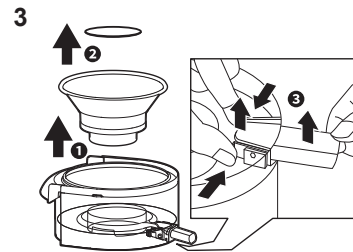

① Angkat pemintal.  
② Tanggalkan pad pemintal dengan memusingkan pemintal terbalik.  
③ Terbalikkan unit bekas dan keluarkan muncung jus dari bekas.

# Cara Menggunakan

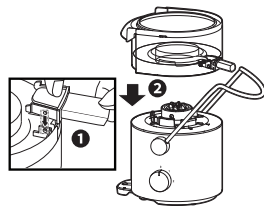

## 1 Terbalikkan bekas dan pasang muncung jus. Letakkan unit bekas pada bahagian motor.

- Pastikan muncung jus dan pengapit diposisikan sama seperti yang digambarkan.
- Pastikan unit bekas terletak dengan betul pada bahagian motor.

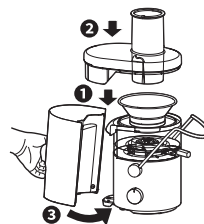

## 2

- ① Letakkan pemintal dalam unit bekas dan pasangannya pada kedudukannya.
- ② Letakkan penutup bekas pada unit bekas.
- ③ Pasangkan bekas pulpa dan pastikan ia sejajar sepenuhnya dengan badan.

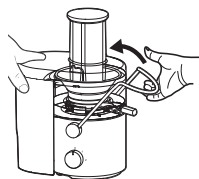

## 3 Tolak pengapit seperti yang ditunjukkan sehingga bunyi kunci kedengaran.

- Jika pengapit tidak diapit dengan betul, motor tidak akan beroperasi.

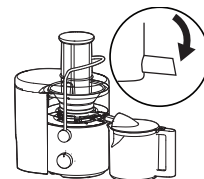

## 4 Letakkan mangkuk jus seperti yang ditunjukkan.

- Pastikan muncung jus berada dalam kedudukan ke bawah semasa membuat jus.

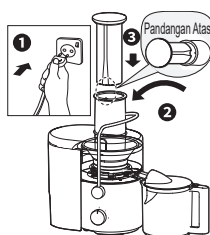

## 5

- ① Pasangkan plag dan hidupkan.
- ② Masukkan bahan satu persatu dan tolak perlahan-lahan ke dalam bukaan penyalur bahan menggunakan penolak bahan.
- ③ Selaraskan penolak bahan ke dalam bukaan penyalur bahan seperti yang digambarkan.

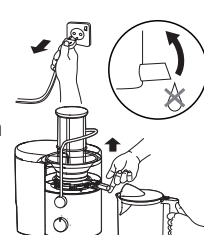

## 6 Selepas penggunaan, matikan dan cabut plag.

- Semasa mengeluarkan mangkuk jus, pastikan muncung jus ditarik ke atas untuk mengelakkan jus daripada menitis.
- Pastikan pemintal dihentikan sepenuhnya sebelum melepaskan pengapit.
- Sesetengah pulpa mungkin sukar dikumpulkan dalam bekas pulpa dan melekat pada penutup bekas bergantung pada ramuan dan jumlahnya.

# Selepas Penggunaan

- Sebelum menanggalkan bahagian-bahagian, pastikan motor telah berhenti sepenuhnya, kemudian cabut palam dari bekalan kuasa.
- Bersihkan bahawa sepenuhnya selepas setiap penggunaan. Pastikan semua bahagian sentiasa bersih dan kering.
- Jangan gunakan benzin, pencair, peluntur, alkohol, span muka nilon, berus logam atau serbuk penggilap dsb.
- Sesetengah perubahan warna plastik mungkin berlaku semasa penggunaan. Walaupun bahagian -bahagian dibasuh dengan span, perubahan warna tidak dapat dikeluarkan sepenuhnya, tetapi ia tidak menjejaskan penggunaan. Jika anda membersihkan bahagian secepat mungkin selepas penggunaan, ia boleh dikeluarkan dengan baik.
- Apabila membersihkan dalam mesin basuh pinggan mangkuk, jangan letakkan objek berat di atas bahagian-bahagian tersebut.

## Pembersihan

									
Air yang Mengalir	✓	✓	✓	✓	✓	✓	✓	✓	✗
Mesin basuh pinggan mangkuk	✓	✓	✓	✓	✓	✓	✓	✗	✗
Kain lembap yang diperah	✓	✓	✓	✓	✓	✓	✓	✗	✓
Berus	✗	✗	✗	✗	✗	✗	✗	✓	✗
Pad gosok	✗	✗	✗	✗	✗	✗	✗	✗	✗
Span Lembut	✓	✓	✓	✓	✓	✓	✓	✗	✓
Catatan	Basuh setiap bahagian dalam air sejuk atau suam dengan span lembut. Bilas dan keringkan dengan teliti sebelum disimpan.							Basuh dengan berhati-hati dengan berus di bawah air yang mengalir.	Lap sebarang kotoran atau kesan dengan kain lembap yang bersih.

Melayu

## Penyimpanan

### Palam dan Wayar

- 1) Balikkan bahagian motor dan gulungkan wayar dua pusingan seperti yang digambarkan.

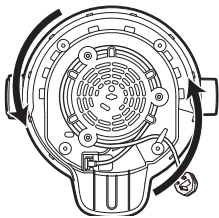

- 2) Masukkan wayar ke dalam pengait wayar agar sesuai dengan kedudukan wayar.

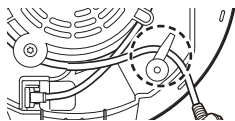

- 1) Balikkan mangkuk jus dan letakkan pada bukaan penyalur bahan.
- 2) Simpan penutup mangkuk di dalam bekas pulpa.

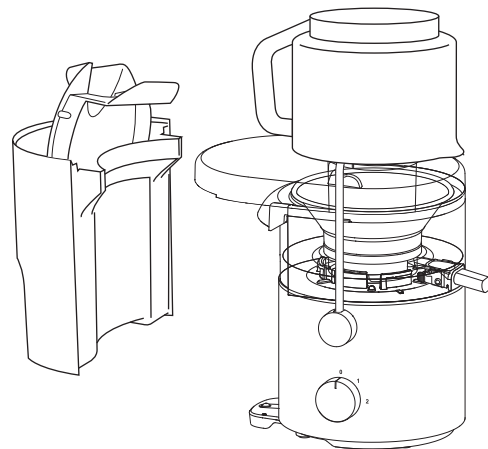



## Penyelesaian Masalah

Sebelum menghubungi untuk pemeriksaan, sila periksa bahagian berikut.

Masalah	Punca dan Tindakan
Perkakas tidak boleh dihidupkan.	<ul style="list-style-type: none"> <li>● <b>Bekas tidak dipasang dengan kemas.</b> → Pasangnya dengan ketat. (P. ML6)</li> <li>● <b>Peranti perlindungan beban lampau atau kepanasan lampau diaktifkan.</b> → Sila rujuk "Perlindungan Beban Melampau dan Kepanasan Melampau" untuk pemeriksaan. (P. ML5)</li> <li>● <b>Palam kuasa diputuskan sambungan.</b> → Masukkan palam kuasa ke dalam salur kuasa dengan kemas.</li> </ul>
Putaran berhenti secara tiba-tiba.	<ul style="list-style-type: none"> <li>● <b>Peranti perlindungan beban lampau atau kepanasan lampau diaktifkan.</b> → Sila rujuk "Perlindungan Beban Melampau dan Kepanasan Melampau" untuk pemeriksaan. (P. ML5)</li> </ul>
Terdapat bunyi yang tidak normal atau peningkatan getaran.	<ul style="list-style-type: none"> <li>● <b>Terlalu banyak bahan.</b> → Kurangkan jumlah bahan.</li> <li>● <b>Unit bekas tidak dipasang dengan ketat.</b> → Pasangnya dengan ketat. (P. ML6)</li> </ul>

## Spesifikasi

<b>Bekalan kuasa</b>	220 - 240 V ~ 50 - 60 Hz
<b>Penggunaan kuasa</b>	270 - 320 W
<b>Masa dinilai</b>	Operasi berterusan (Ulangi kitaran 2 minit BUKA dan kemudian 2 minit TUTUP)
<b>Ukuran (Anggaran.) (P x L x T)</b>	208 x 304 x 386 (mm)
<b>Berat (Anggaran.)</b>	3.6 kg
<b>Kapasiti (Anggaran.)</b>	Kapasiti kerja: Mangkuk Jus: 1.5 L; Bekas Pulpa: 2.0 L



# Memo