







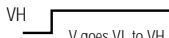

## FEATURES

### Specifications of Various Sensors

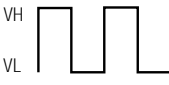
LOCKED ROTOR ALARM SIGNAL			
Signal given when fan is running	Signal given when fan is locked up	Available Models	Part Number Suffix
VH  VL 	VH  VL  V goes VL to VH	Axial models FBK04F	1BS S
		FAL	S
		FCB	S

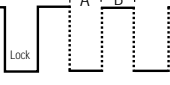
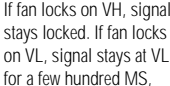
2 PULSE PER REVOLUTION SIGNAL			
Signal given when fan is running	Signal given when fan is locked up	Available Models	Part Number Suffix
VH  VL 	VH  VL  Lock A B I	Axial models except: FBK04F FBA06T FBA08T FCB FAL	1BX
	If fan locks on VH, signal stays locked. If fan locks on VL, signal stays at VL for a few hundred MS, then moves to VH. (A:B -1:5; A ≥ 100MS)		
			

In Panaflo FBA series models, a locked rotor alarm sensor is available in all models.

For Blowers and Crossflo fans, a locked sensor can be provided as an option.

A pulse sensor that transmits signals when the motor rotates is also available as an option.

The 2 pulse per revolution sensor output is available in all FBA Series models except the 15 mm "T" versions.

### Panaflo Built-in Connector System

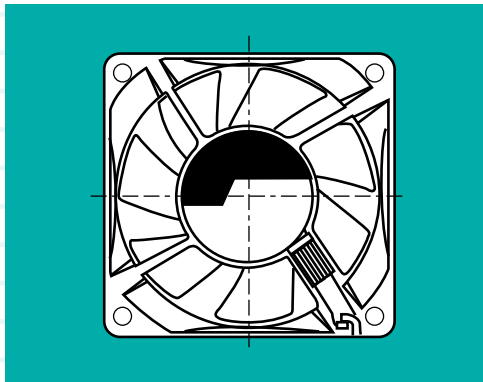

Lead Wire Connectors:

- Style: MASS TERMINATION (standard)  
AMP P/N 173977-3
- CRIMP TYPE (this style is a 2 piece assembly)  
AMP P/N 175778-3 (housing)  
AMP P/N 175102-1 (terminal)

Notes:

- Connector style effects lead wire gauge.  
Please refer to fan specs for further details.
- All axial fans except the FBA06T, FBA08T and FBK04F versions come standard with the mass termination connector. The FBA06T, FBA08T and FBK04F fan leads are connected directly to the PC board in the fan assembly.
- All FCB Crossflo models and FAL Blower fan leads are soldered directly to the PC board in the fan assembly.

## High Reliability with HWB (Hydro Wave Bearing)

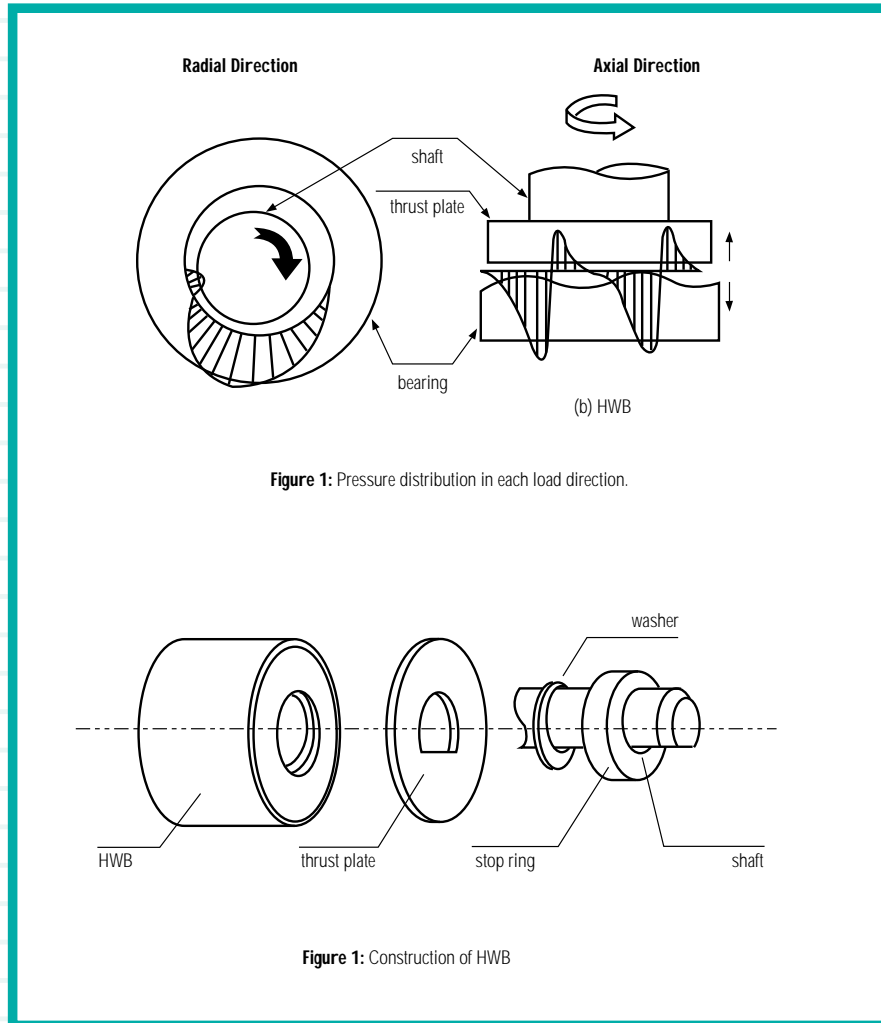

Figure 1: Pressure distribution in each load direction.

Figure 1: Construction of HWB

Panflo's unique hydrowave bearing (HWB) addresses the traditional weakness of sleeve bearings... axial friction. By utilizing our unique HWB system, the thrust plate "floats" on a circulating film of oil, which greatly reduces the axial friction and the bearing's deterioration. The HWB pattern on the bearing virtually eliminates thrust plate contact which is depicted above.

As the shaft rotates it acts as a pump constantly circulating the oil in the radial, as well as the axial direction. The sealed system and reservoirs of oil maintain the proper lubrication to minimize mechanical contact and prolong the fan's life expectancy. The radial direction analysis shown above is essentially the same as a traditional sleeve bearing. Panasonic's unique HWB reduces the axial contact.