

# Manganese Dioxide Lithium Cylindrical Batteries: Individual Specifications

## CR2

### ■ Dimensions(mm)

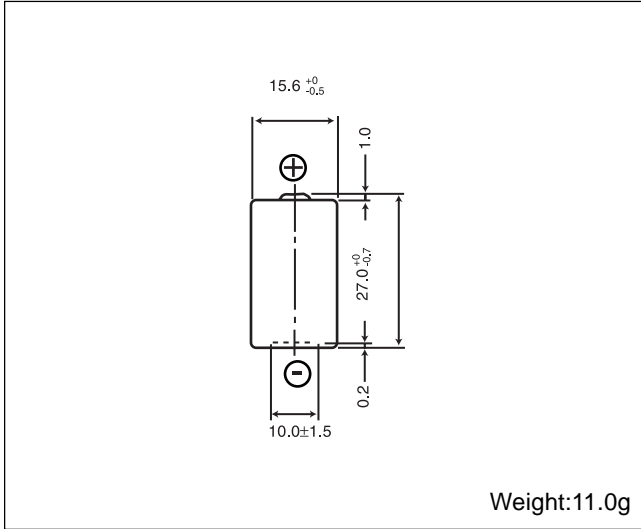

Weight:11.0g

### ■ Specification

Nominal voltage (V)	3
Nominal capacity (mAh)	750
Continuous standard load (mA)	20
Operating temperature (C)	-40 ~ +70*

\* Please consult Panasonic for use below and above -20°C to +60°C

### ■ Temperature Characteristics

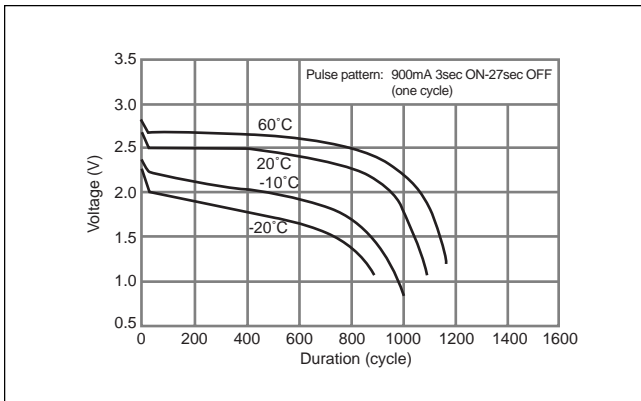

\* Please consult Panasonic for use below and above -20°C to +60°C

## CR123A

### ■ Dimensions(mm)

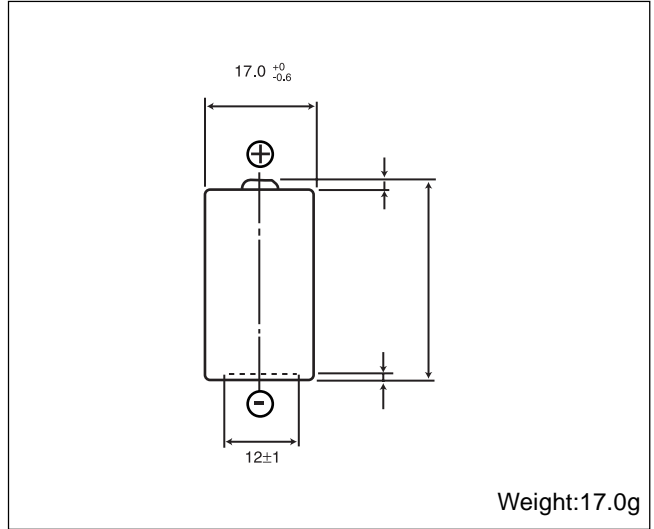

Weight:17.0g

### ■ Specification

Nominal voltage (V)	3
Nominal capacity (mAh)	1,550
Continuous standard load (mA)	20
Operating temperature (C)	-40 ~ +70*

### ■ Temperature Characteristics

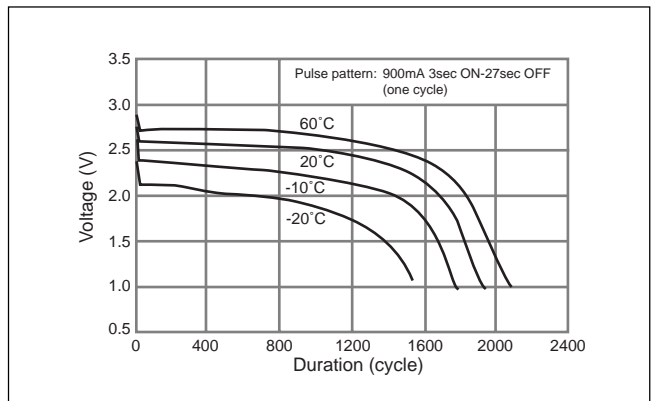

\* Please consult Panasonic for use below and above -20°C to +60°C