

# CHARGE METHODS FOR NI-CD BATTERIES

If the charge conditions are not appropriate, not only will the batteries not display their full performance potential, but the cycle life could also be shortened, and in extreme cases, electrolyte leakage could damage the device in which the batteries are used. Therefore, carefully select the appropriate charge method, taking into consideration the type of battery,

the state of discharge, the charge current, and the ambient temperature.

The charge methods for Ni-Cd batteries can be generally classified into two types according to the purpose for which the batteries are used: cycle use and standby use.

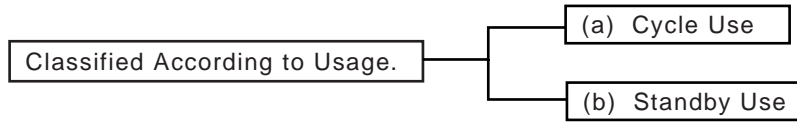

## (a) Cycle Use

The battery is repeatedly charged and discharged. This is the most common method for using Ni-Cd batteries.

## (b) Standby Use

Power is normally supplied to the load from an AC power supply, and the Ni-Cd battery is used to maintain the power supply to the load in the event that the AC power supply is interrupted.

## (1) Methods of Charge for Ni-Cd Battery

The methods of charge for Ni-Cd batteries can be classified as follows according to the purpose of use and the charge time.

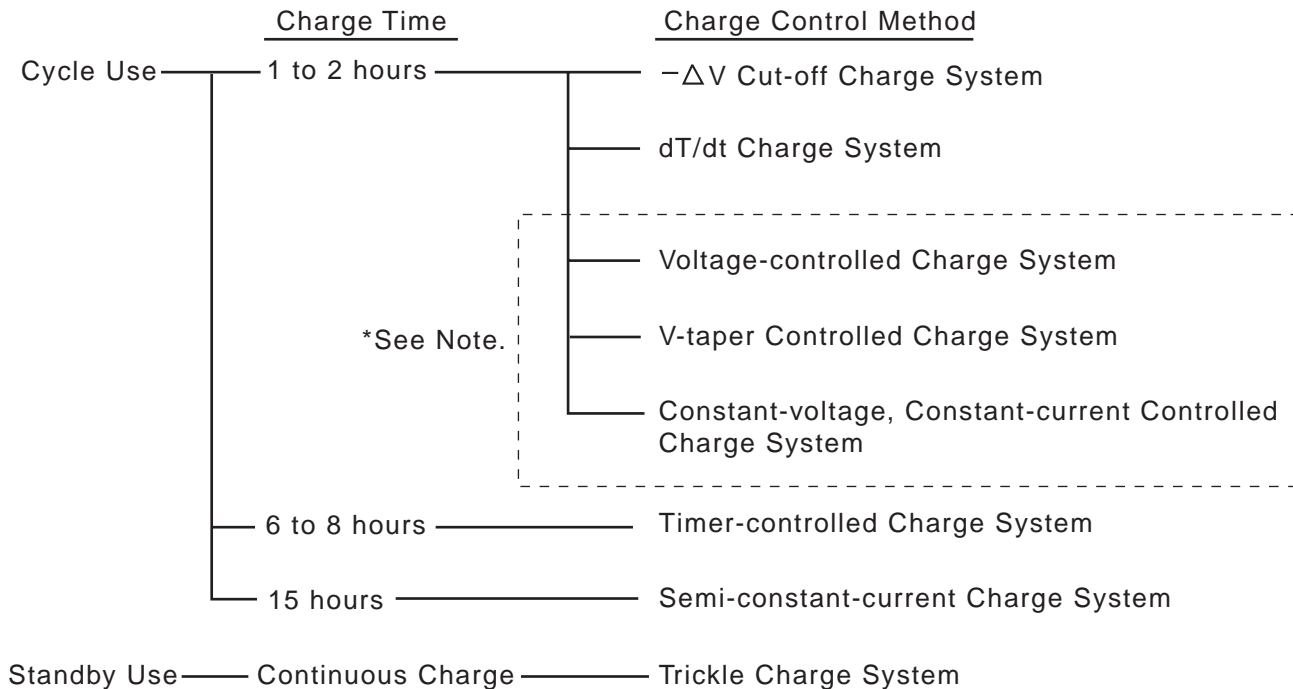

\* Not a recommended charge method for Ni-Cd batteries

# CHARGE METHODS FOR NI-CD BATTERIES - CONTINUED

## (2) General Comparison of the Various Charge Systems

Charge System	Cycle (Repeated) Use				Standby Use
	Semi-constant Current Charge	Timer Controlled Charge	- $\Delta V$ Cut-off Charge	dT/dt Cut-off Charge	Trickle Charge
Operation V <sub>B</sub> : Battery Voltage I <sub>ch</sub> : Charge Current T: Battery Temperature					
Features	<ul style="list-style-type: none"> <li>* Most typical charge system</li> <li>* Simple and economical</li> </ul>	<ul style="list-style-type: none"> <li>* More reliable than Semi-constant current charge system</li> <li>* Relatively simple and economical</li> </ul>	<ul style="list-style-type: none"> <li>* Most popular</li> </ul>	<ul style="list-style-type: none"> <li>* Charging circuit costs more than the others but overcharge can be avoided enabling longer life cycle than - <math>\Delta V</math> charge method</li> </ul>	<ul style="list-style-type: none"> <li>* Simple and economical</li> <li>* Applicable to the equipment for continuous long charge</li> </ul>
No. of Output Terminals	2	2	2	3	2
Charge Time	15 hours	6 to 8 hours	1 to 2 hours	1 to 2 hours	30 hours or longer
Charge Current	0.1 CmA	0.2 CmA	0.5 to 1 CmA	0.5 to 1 CmA	<ul style="list-style-type: none"> <li>* frequent charge: 0.05-0.033 CmA</li> <li>* less frequent charge: 0.033-0.02 CmA</li> </ul>
Trickle Current	---	0.05-0.033 CmA	0.05-0.033 CmA	0.05-0.033 CmA	
Charge Level at Charge Control	---	approx. 120%	approx. 110 to 120%	approx. 100 to 110%	---
"S" Type	---	---	⊗	○	---
"R" Type	○	○	⊗	○	---
"P" Type	○	○	⊗	⊗	---
Application Examples	<ul style="list-style-type: none"> <li>* Shavers</li> <li>* Digital cordless phones</li> <li>* Toys</li> </ul>	<ul style="list-style-type: none"> <li>* Cordless Phone</li> <li>* Shavers</li> </ul>	<ul style="list-style-type: none"> <li>* Data Terminals</li> <li>* Camcorder</li> <li>* Wireless equipment</li> <li>* Cellular phones</li> </ul>	<ul style="list-style-type: none"> <li>* Power Tools</li> <li>* Electric Tools</li> <li>* Notebook PC</li> <li>* Cellular phones</li> </ul>	<ul style="list-style-type: none"> <li>* Emergency lights</li> <li>* Guide lights</li> <li>* Memory back-up</li> </ul>

⊗: Most recommended  
 ○: Acceptable

# CHARGE METHODS FOR NI-CD BATTERIES - CONTINUED

## (2) General Comparison of the Various Charge Systems - Continued

Charge System	For Reference Only ( <u>Not</u> Recommended for the Main Charge Control System for Ni-Cd Batteries.)		
	Voltage Controlled Charge System	V-taper Controlled Charge System	Constant-voltage, Constant-current Controlled Charge System
Operation V <sub>B</sub> : Battery Voltage I <sub>ch</sub> : Charge Current T: Battery Temperature CV: Constant Voltage			
Features	* Not recommended for the main charge control system for Ni-Cd batteries	* Not recommended for the main charge control system for Ni-Cd batteries. * Recommended charge control system for sealed lead acid batteries.	* Not recommended for the main charge control system for Ni-Cd batteries.
No. of Output Terminals	---	---	---
Charge Time	---	---	---
Charge Current	---	---	---
Trickle Current	---	---	---
Charge Level at Charge Control	---	---	---
"S" Type	---	---	---
"R" Type	---	---	---
"P" Type	---	---	---
Application Examples	---	---	---

# CHARGE METHODS FOR NI-CD BATTERIES - CONTINUED

## (3) Details of Each Charge Method

### Semi-constant-current Charge System

#### (1) Mechanism

##### (A) Mechanism

A resistance is positioned between the DC power supply and the battery, thus stabilizing the charge current. By keeping the charge current low enough that the battery does not generate any heat, this method performs charge without using any control.

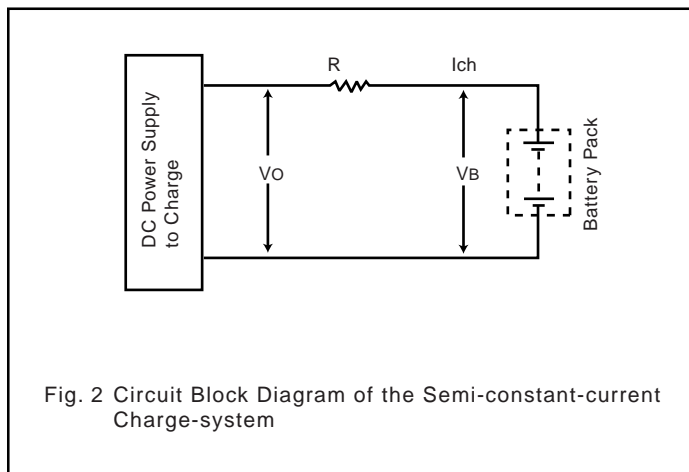
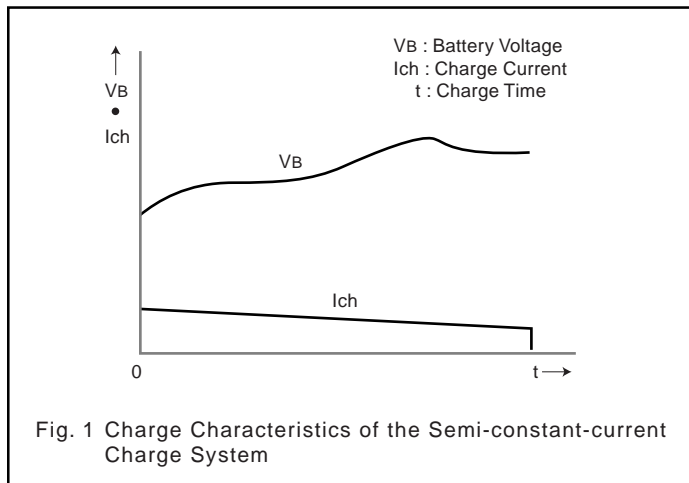

#### (B) Calculation Example

The calculation formula for the block diagram of the semi-constant-current charge system shown in Fig. 1 is as follows.

$V_o$  = Output voltage of the DC power supply for charge

$V_c$  = Single-cell battery voltage (1.45 V/cell: average battery voltage during charge at 20°C, 0.1 CmA)

$N$  = Number of cells used

$V_B$  = Battery voltage ( $V_c \times N$ )

$R$  = Charge current stabilizing resistance

$I_{ch}$  = Charge current

$$I_{ch} = \frac{V_o - V_B}{R} = \frac{V_c \times N \times (K) - V_c \times N}{R}$$

(K) is the stabilizing constant and must be selected in accordance with the purpose of the device in which the battery pack is used.

#### (2) Features

- The standard charge method for Ni-Cd batteries.
- The charger construction is simple and inexpensive.

#### (3) General Specifications

	Typical General Specifications
Number of Charger Output Terminals	2
Charge Current	0.1CmA
Charge Time	15 hours
Applicable Battery Types	R P

#### (4) Cautions

- If the specific conditions of the device require that a charge rate higher than 0.1 CmA be used, the overcharge performance and temperature rise characteristics will vary according to the battery type. Consult Panasonic for further details and specifications.
- If a large number of battery cells are used, or if batteries having a high nominal capacity are used, or if the heat dissipation of the battery pack is poor, the batteries may generate heat even when charged at 0.1 CmA. In such cases, it is necessary to re-design the construction for better heat dissipation or to lower the charge current. Design so that the battery temperature rise at saturation is no higher than 50°C.
- The value of the above-mentioned stabilizing constant (K) must be selected carefully. If the value of K is too small, the fluctuation of the charge current with respect to the fluctuation of the power supply voltage will increase, and this could cause insufficient charge or overcharge.

# CHARGE METHODS FOR NI-CD BATTERIES - CONTINUED

- When the batteries reach the end of their cycle life, the usage time will become markedly shorter, and eventually two malfunction modes will occur: an internal short-circuit and the exhaustion of the electrolyte (the internal resistance will increase). Therefore, when designing the charger and the charge circuit, these malfunction modes (output short-circuit, etc.) at the end of the cycle life must be taken into consideration. Special care is required regarding the rated load of the charge current stabilizing resistance R so that an overload does not occur at the time of these battery malfunction modes.

## Timer-controlled Charge System

### (1) Mechanism

At the start of charge, an IC timer is started (counts up), and charge is continued at a current of 0.2 CmA for a specified time until the timer stops. After the timer stops, trickle charge continues at 0.05 CmA.

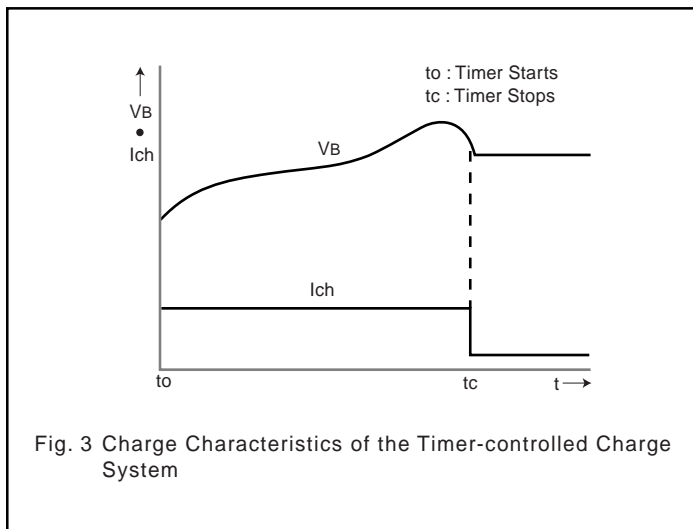

Fig. 3 Charge Characteristics of the Timer-controlled Charge System

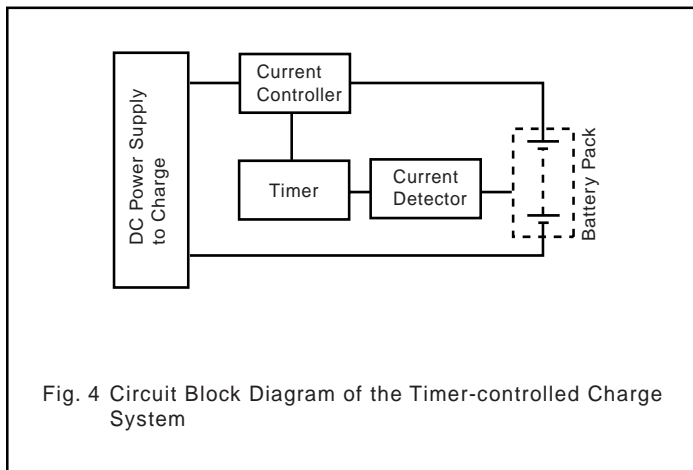

Fig. 4 Circuit Block Diagram of the Timer-controlled Charge System

### (2) Features

- Compared with the semi-constant-current charge system (non-controlled), the addition of a charge timer improves the long-term reliability of charge.
- The construction of the charge circuit is relatively simple and inexpensive.

### General Specifications

	Typical General Specifications
Number of Charger Output Terminals	2
Charge Current	0.2CmA
Charge Time	6 hours
Charge Level Until Timer Stops	120%
Trickle	Charge Current 0.05CmA
Applicable Battery Types	S R P

### (3) Cautions

- This method is not appropriate for applications in which the timer is frequently reset (charge is restarted).
- If frequent resetting of the timer is required, or if the specific conditions of the device require that a charge rate higher than 0.2 CmA be used (for example, timer-controlled charge at 0.3 CmA), it is necessary to combine this method with an absolute temperature cut-off charge system.
- The overcharge performance will vary according to the battery type.

## - Δ V Cut-off Charge System

### (1) Mechanism

If rapid charge Ni-Cd batteries are charged at a constant current, the battery voltage will increase as charge progresses, peak when charge is completed, and then subsequently decrease. Because this voltage drop occurs regardless of the discharge level or ambient temperature, it can be effectively used to detect the completion of charge. The -ΔV cut-off charge system controls charge by detecting the voltage drop (-ΔV) following the peak.

# CHARGE METHODS FOR NI-CD BATTERIES - CONTINUED

## (2) Features

- The most common control method for rapid charge.
- The most recommended and widely used method for the rapid charge of Ni-Cd batteries for use in high-tech devices (for example, portable VCR, notebook PC, digital cordless and cellular phones, etc.).

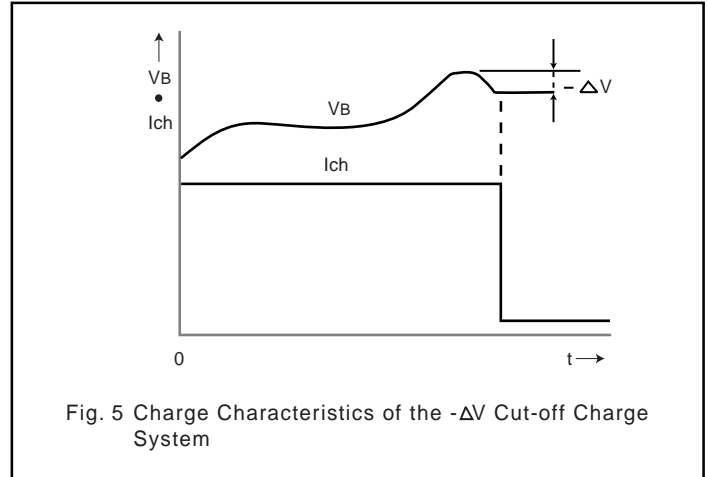

Fig. 5 Charge Characteristics of the  $-\Delta V$  Cut-off Charge System

## (3) General Specifications

	Typical General Specifications	Remarks
Number of Charger Output Terminals	2	
Charge Current	0.5 to 1.0 CmA	See (5) in Fig. 6
Charge Time	1 to 2 hours	
Charge Level at $-\Delta V$ Cut-off	approx. 110 to 120%	
Trickle Charge Current	0.05 CmA	See (6) in Fig. 6
$-\Delta V$ Value	15 to 20 mV/cell	See (3) in Fig. 6
Charge Mode Switching (1) (From Rapid Charge to Trickle Charge)	1.95 V/cell	See (2) in Fig. 6
Charge Mode Switching (2) (From Initial Charge to Rapid Charge)	0.8 to 1.0 V/cell	See (4) in Fig. 6
Initial Charge Current	approx. 0.2 CmA	See (7) in Fig. 6
Total Timer Time	Time corresponding to a 150% charge level of the nominal capacity at the rapid charge current	See (8) in Fig. 6
Initial Delay Timer	approx. 5 min.	See (1) in Fig. 6
Safety Device	Thermal protector (included in the battery pack)	See Fig. 7 and 8
Applicable Battery Types	S R P	

# CHARGE METHODS FOR NI-CD BATTERIES - CONTINUED

## (3) Precautions

- This method is suitable for rapid charge Ni-Cd batteries.
- The charge current should be 0.5 CmA ~ 1 CmA. If charged at less than 0.5 CmA, the voltage drop after the peak voltage is reached might be too small for the  $-\Delta V$  cut-off to function, resulting in overcharge. The maximum charge current will vary according to the specific type of battery, so it is important to select the appropriate charge current. (See (5) in Fig. 6)
- A constant-current power supply circuit is required. If fluctuations in the charge current occur as a result of fluctuations in the power supply voltage, the charge voltage will change, and faulty operation (stopping of charge before completion) of the charger might occur.
- The voltage detector shown in the block diagram must be provided with a noise canceller in order to prevent external noise from causing faulty operation (stopping of charge before completion) of the charger.
- An initial delay timer is needed in order to prevent faulty operation (stopping of charge before completion) of the charger from being caused by any false  $-\Delta V$  phenomenon at the beginning of charge.

**False  $-\Delta V$  phenomenon:** When Ni-Cd batteries are left unused for a long period of time or excessively discharged, the charge voltage (false  $-\Delta V$ ) may swing at the beginning of charge. (See (1) in Fig 6)

**Initial delay timer:** Prevents the  $-\Delta V$  detection circuit from functioning for a certain length of time after rapid charge is begun.

- Be sure that the  $-\Delta V$  value is correct. If it is not, faulty operation (overcharge or insufficient charge) of the charger might occur. (See (1) in Fig. 6)
- A voltage detection switch must be provided in order to change from the rapid-charge current to the trickle charge current when the charge voltage reaches the predetermined level. This predetermined level varies according to the type of battery, so consult Panasonic for the specific level. The trickle charge current should be 0.05 CmA. (See (2) and (6) in Fig. 6)
- If a voltage detection switch is provided in order to switch the charger to the rapid charge mode, set the voltage value to 0.8 to 1.0 V/cell. In addition, for the period of initial charge (before the start of rapid charge) until the battery voltage reaches the

predetermined level, set the charge current to approximately 0.2 CmA. (See (5) and (7) in Fig. 6)

- Provide a total timer in the charge circuit as a double-safety control. (See (8) in Fig. 6)
- A thermal protector (thermostat) and other safety devices are needed inside the battery pack to ensure the safety of rapid charge. (See Figs. 7 and 8.)
- Especially for devices where charge is frequently performed at high temperatures or low temperatures (for example, chargers designed to be used in an automobile), in order to increase charge reliability, the charger is provided with a function that detects the temperature of the batteries and switches to trickle charge if the temperature is not within the specified range for rapid charge. Therefore, a thermistor or other temperature-detecting element must be provided inside the battery pack, and the battery pack will have a 3-terminal construction. (See (9) in Fig. 6 and Fig. 7)

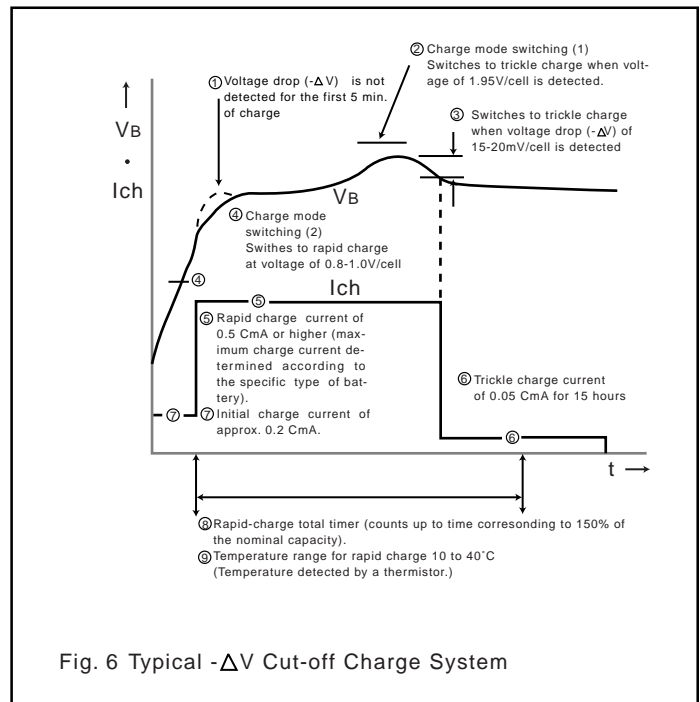

Fig. 6 Typical  $-\Delta V$  Cut-off Charge System

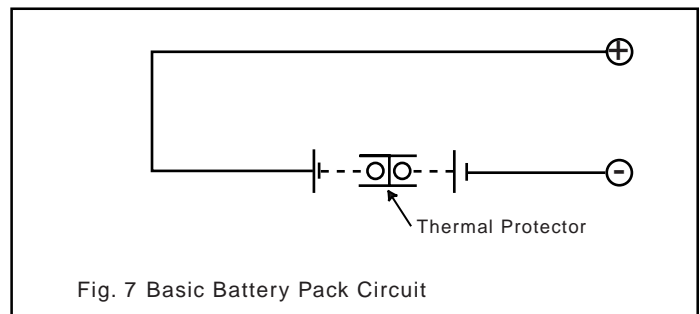
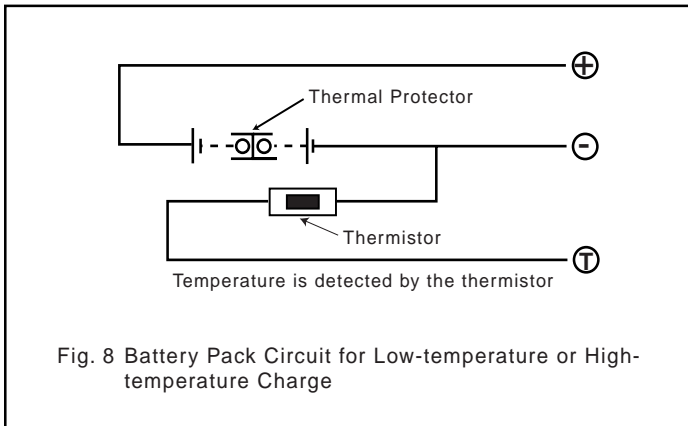

Fig. 7 Basic Battery Pack Circuit

## CHARGE METHODS FOR NI-CD BATTERIES - CONTINUED



### Trickle Charge System

There are generally two types of uses for trickle charge; As a standby power supply for devices such as emergency lights, and for additional charge following rapid charge. When used as a standby power supply, the appropriate charge current varies according to the frequency of discharge.

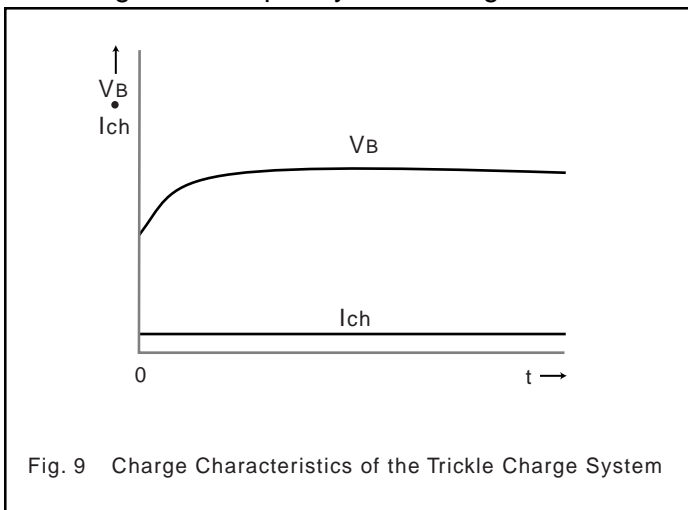

# CHARGE METHODS FOR NI-CD BATTERIES - CONTINUED

## (1) Mechanism

While the AC power is being supplied, the battery is disconnected from the load and is charged by a very small current which only replenishes the self-discharge of the battery. Only in the event of an interruption in the AC power supply does power flow from the battery to the load.

## (2) Features

- Mainly used as a standby power supply for emergency lights and other disaster-prevention equipment.
- The main purpose of trickle charge is to replenish the self-discharge of the battery, using a very small charge current of 0.02 to 0.05 CmA. It takes many hours to completely charge.

## (3) General Specifications (Trickle Charge Current)

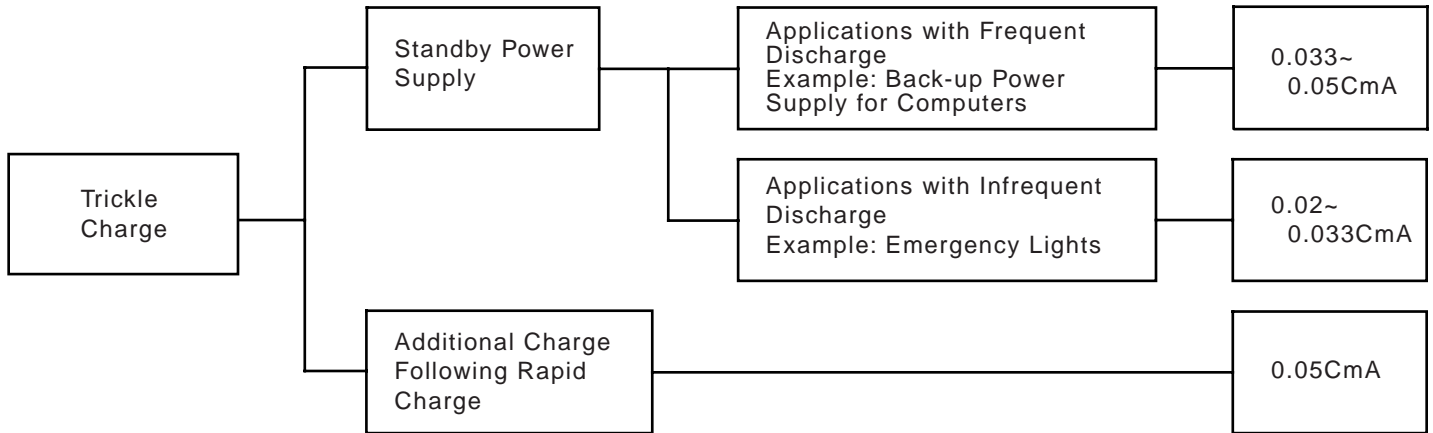

## (4) Precautions

- The trickle charge current for use as a standby power supply should be set to a level at which charge will be completed by time of the next discharge, taking into consideration the frequency of discharge and the discharge current.
- If recovery charge at a relatively large current (for example, 0.1 CmA) is required, combine trickle charge with some other suitable charge control system (for example, timer-control charge).

## Voltage-controlled Charge System (for Reference Only)

### (1) Mechanism

The charge voltage at the completion of charge is detected (the detection voltage can be freely set) by a voltage detection circuit inside the charger, and the charger switches from rapid charge to trickle charge. To compensate for temperature-related fluctuations in the charge voltage of Ni-Cd batteries, temperature compensation is added to the detection voltage.

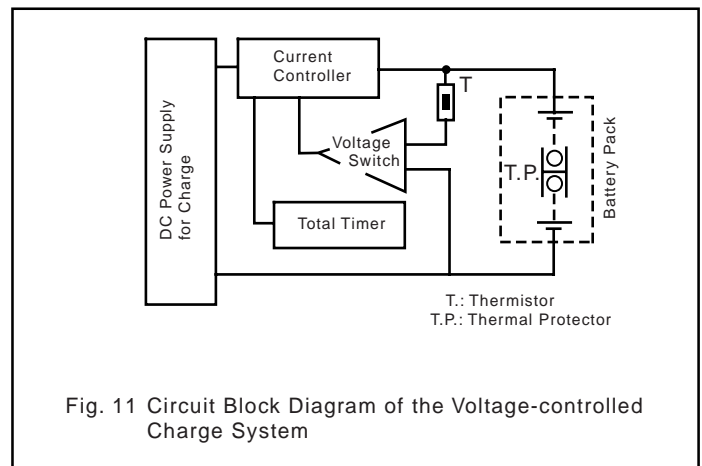
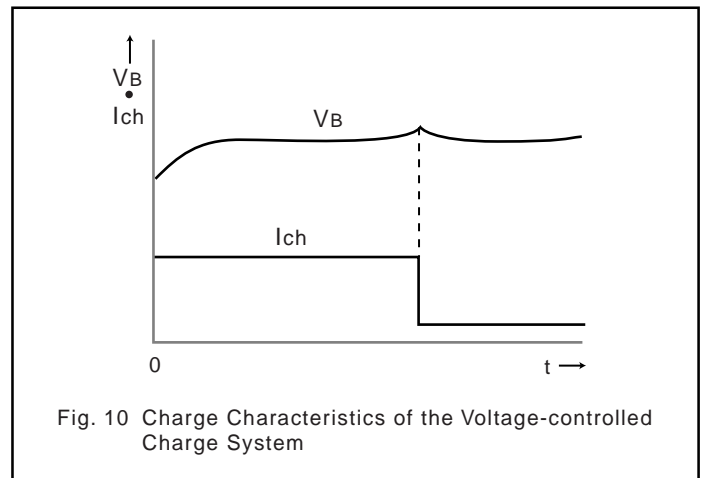

# CHARGE METHODS FOR NI-CD BATTERIES - CONTINUED

## (2) Features

This method is rarely used today, and it is not appropriate for the charge control system for Ni-Cd batteries.

Matching the charger to the batteries is extremely difficult, and if the detection voltage of the charger is not set correctly, insufficient charge or overcharge (thermal runaway) can easily occur.

## General Specifications

	Typical General Specifications
Number of Charger Output Terminals	2
Charge Current	0.5 ~ 1.0 CmA
Charge Time	1 to 2 hours (complete charge is difficult even with a longer charge time)
Charge Level at Voltage Control	Approx. 70%
Trickle Charge Current	0.05 CmA
Detection Voltage	(Detection voltage must be compensated for the temperature.)
Safety Device	Thermal protector + total timer
Applicable Battery Types	(Not recommended for use as the main charge control system for Ni-Cd batteries.)

## (3) Precautions

- The setting of the detection voltage is extremely difficult. The setting of the detection voltage and of the temperature compensation must be done carefully, taking into consideration the variations and fluctuations of the batteries and of the charger as indicated below, and in order to avoid overcharge (thermal runaway), the detection voltage is generally set for insufficient charge. Batteries: Single-cell and multi-cell (battery pack) variations in the charge voltage, and fluctuation of the charge voltage caused by the ambient temperature.  
Charger: Variations in the adjustment of the set detection voltage, and fluctuation of the detection voltage caused by the ambient temperature.
- The charge voltage increases in batteries which have been left unused for a long period of time, and during charge the charge voltage will quickly reach the charger's detection voltage. Therefore, if the voltage-controlled charge control system is used to charge batteries which have not been used for a long period of time, the charge level will be low. Matching the charger to the batteries is extremely difficult, and if the detection voltage of the charger is not set correctly, insufficient charge

or overcharge (thermal runaway) can easily occur. Therefore, this method should never be used as the main charge control system for Ni-Cd batteries.

## V-taper Controlled Charge System

This is the charge control method recommended for Sealed Lead Acid batteries, and it is not recommended for charge Ni-Cd batteries.

## (1) Mechanism

This system is basically the same as the voltage-controlled charge system already described. However, in the V-taper controlled charge system, after the set voltage is detected at the completion of charge, the

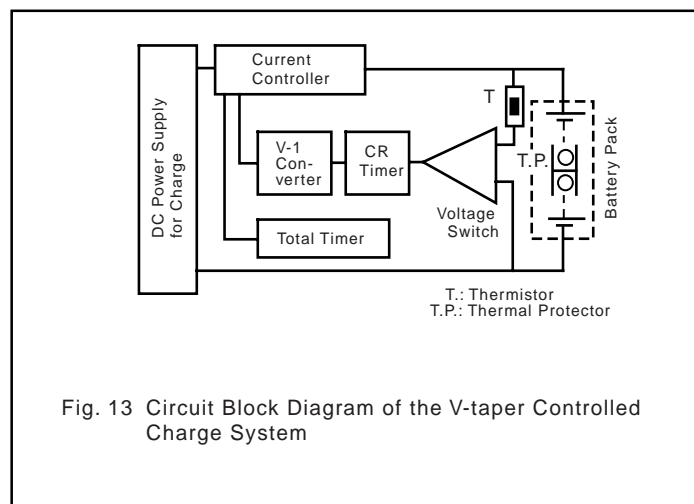
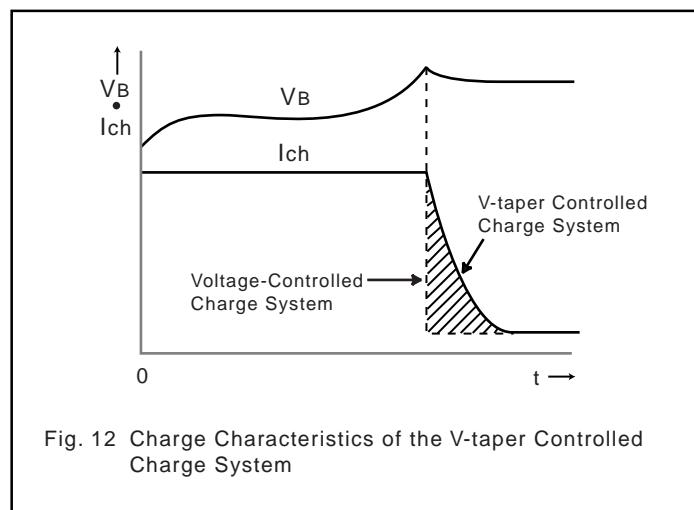

rapid charge current is supplied as a tapered current, decreased at a predetermined rate over a predetermined length of time, and then switched to trickle current. Supplying the decreasing taper current makes it possible to achieve a higher charge level than with the voltage-controlled charge system.

## CHARGE METHODS FOR NI-CD BATTERIES - CONTINUED

### (2) Features

- This is the recommended charge control system for Sealed Lead Acid batteries.
- In comparison with the voltage-controlled charge system, this method is capable of increasing the charge level by the amount indicated by the shaded area in Fig. 12. However, just as for the voltage-controlled charge system, the setting of the detection voltage is extremely difficult when charge Ni-Cd batteries.

### (3) General Specifications

Because this system is currently used only as a rapid charge method for Sealed Lead Acid batteries, the specifications are not included here.

### (4) Precautions

This charge method is basically the same as the voltage-controlled charge system, and it is not appropriate for charge Ni-Cd batteries.

### Constant-voltage, Constant-current Controlled Charge system

This is the basic charge system for Sealed Lead Acid batteries, and it is not recommended for charge Ni-Cd batteries.

### (1) Mechanism

The charge voltage of Sealed Lead Acid batteries rises sharply at the completion of charge and is subsequently maintained at that level. The constant-voltage, constant-current controlled charge system utilizes these charge voltage characteristics to complete (control) charge using only a constant-voltage power supply with no external control. When the battery voltage is lower than the constant voltage, charge is carried out in the constant-current range, and when the battery voltage reaches the level of the constant-voltage, the charge current is decreased to a trickle current.

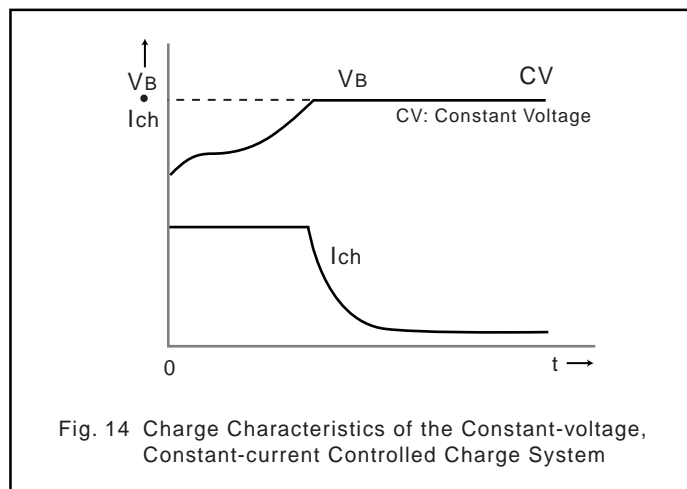

Fig. 14 Charge Characteristics of the Constant-voltage, Constant-current Controlled Charge System

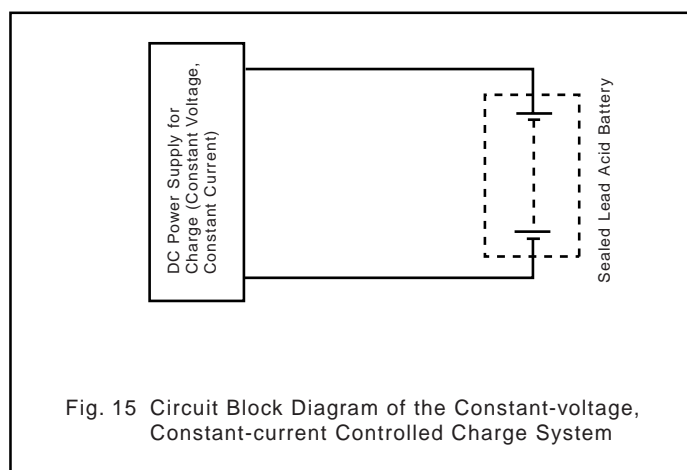

Fig. 15 Circuit Block Diagram of the Constant-voltage, Constant-current Controlled Charge System

### (2) Features

Because this method is used only for charge Sealed Lead Acid batteries, the features are not included here.

### (3) General Specifications

Because this method is used only for charge Sealed Lead Acid batteries, the specifications are not included here.

### (4) Cautions

The charge voltage characteristics of Ni-Cd batteries exhibit a peak at the completion of charge, and subsequently drop. Therefore, if the constant-voltage, constant-current controlled charge system were to be used to charge Ni-Cd batteries, the charge current would be increased again, and thermal runaway would occur. This method is not suitable, and is not recommended for charge Ni-Cd batteries.

# CHARGE METHODS FOR NI-CD BATTERIES - CONTINUED

## Differences Between the Basic Charge Methods for Ni-Cd and Valve-Regulated Lead Acid Batteries (Previously SLA)

### (1) Basic Charge Methods

A comparison of the charge voltage characteristics of Ni-Cd batteries and VRLA batteries shows major differences in the behavior of the charge voltage, such as at the completion of charge. With Ni-Cd batteries, the charge voltage reaches a peak at the completion of charge and subsequently drops, while with VRLA batteries, the charge voltage is maintained at the high level reached at the completion of charge and does not subsequently drop. Due to such

differences, the overcharge voltage characteristics also differ greatly between the two types of batteries. Therefore, if the incorrect type of charge system is used, it will be impossible to match the charger to the batteries, thus leading to problems. The following is a summary of the basic charge methods for the two types of batteries.

- For Ni-Cd batteries: Constant-current controlled charge system (Semi-constant-current charge system).
- For VRLA batteries: Constant-voltage, constant-current controlled charge system.

### (2) General Comparison of the Basic Charge Methods

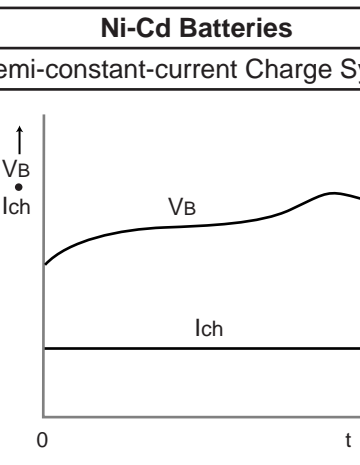
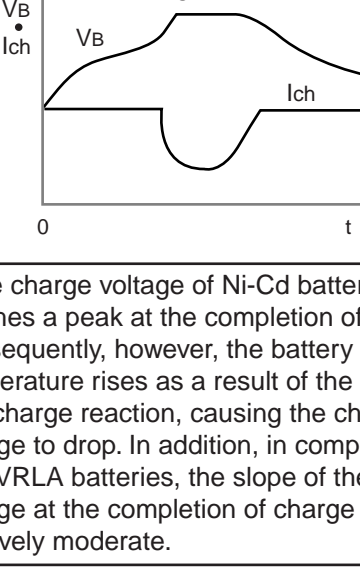
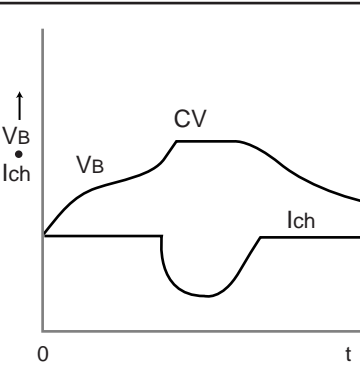
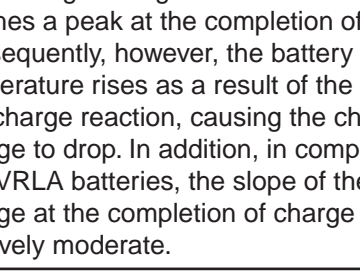
Batteries	Ni-Cd Batteries	Sealed Lead Acid Batteries
Constant-current Controlled Charge System	(Semi-constant-current Charge System) 	Suitable 
Constant-voltage, Constant-current Controlled Charge System	Not Suitable 	Suitable 
Charge Voltage Characteristics (Summary)	* The charge voltage of Ni-Cd batteries reaches a peak at the completion of charge. Subsequently, however, the battery temperature rises as a result of the overcharge reaction, causing the charge voltage to drop. In addition, in comparison with VRLA batteries, the slope of the voltage at the completion of charge is relatively moderate.	* The charge voltage of VRLA batteries rises sharply at the completion of charge, and is subsequently maintained at a relatively high level.
V <sub>B</sub> : Battery Voltage    I <sub>ch</sub> : Charge Current    CV: Constant Voltage		

## CHARGE METHODS FOR NI-CD BATTERIES - CONTINUED

### Confirming the Charge Specifications

In order to be able to fully display the characteristics of Ni-Cd batteries, it is important to confirm the

#### Charge Specification Checklist

- Applicable batteries \_\_\_\_\_
- Number of cells used \_\_\_\_\_
- Charge power supply
  - AC \_\_\_\_\_ V
  - DC car battery \_\_\_\_\_ V
  - Other \_\_\_\_\_
- Charge temperature \_\_\_\_\_ °C to \_\_\_\_\_ °C (Standard charge: 0°C to 45°C); (rapid charge: 10°C to 40°C)
- Charge type
  - Cycle use
  - Standby use
  - Other \_\_\_\_\_
  - Semi-constant-current charge (non-controlled)
- Charge current \_\_\_\_\_ mA
  - Trickle charge
  - Timer-control charge
- Timer time \_\_\_\_\_ hrs.
- Trickle current following timer control \_\_\_\_\_ mA
- Timer reset method
  - When charge power supply is input
  - When battery pack is loaded
- Reset frequency \_\_\_\_\_ times/day
  - $\Delta V$  cut-off charge
- Constant-current power supply
  - Yes
  - No
- Trickle current following -  $\Delta V$  control
  - Yes \_\_\_\_\_ mA
  - No
- -  $\Delta V$  value \_\_\_\_\_ mV/cell
- Charge mode switch (1) (See Fig. 7.)
  - Yes  $\pm$  \_\_\_\_\_ V/cell
  - No
- Charge mode switch (2) (See Fig. 7.)
  - Yes  $\pm$  \_\_\_\_\_ V/cell
  - No
- Initial charge current \_\_\_\_\_ mA
- Initial delay timer
  - Yes \_\_\_\_\_ min.
  - No

#### Two important points for obtaining maximum performance from Ni-Cd batteries

- (1) Select a type of battery suitable for the purpose.
- (2) Set the charge characteristics correctly. In particular, if the charge conditions are not appropriate,

not only will the batteries not display their full performance potential, but the cycle life could be shortened, and in extreme cases, electrolyte leakage could cause damage to the device in which the batteries are used. It is important to consult Panasonic from the initial stages of charger design.

- Total timer
    - Yes \_\_\_\_\_ hrs.
    - No
  - Battery temperature detection function (Detects the battery temperature and switches to trickle charge at beginning of charge.)
    - Yes, low temperature \_\_\_\_\_ °C
    - Yes, high temperature \_\_\_\_\_ °C
    - No
    - Absolute temperature cut-off charge
  - Control temperature \_\_\_\_\_  $\pm$  \_\_\_\_\_ °C
  - Trickle current following absolute temperature control
    - Yes \_\_\_\_\_ mA
    - No
  - Temperature-detecting elements
    - Thermistor
    - B constant \_\_\_\_\_  $\pm$  \_\_\_\_\_ %
    - R25°C \_\_\_\_\_ kW  $\pm$  \_\_\_\_\_ %
  - Manufacturer's name \_\_\_\_\_  
Model No. \_\_\_\_\_
    - Thermostat (bimetal type)
  - Operating temperature \_\_\_\_\_  $\pm$  \_\_\_\_\_ °C  
Manufacturer's name \_\_\_\_\_  
Model No. \_\_\_\_\_
    - Other temperature-detecting element
    - Element name \_\_\_\_\_
    - Manufacturer's name \_\_\_\_\_
    - Model No. \_\_\_\_\_
  - Retention circuit following completion of charge
    - Yes
    - No
  - Total timer \_\_\_\_\_
    - Yes
    - No
    - Other rapid charge control system
  - Trickle current \_\_\_\_\_ mA
- Summary of the rapid charge system operation

ate, not only will the batteries not display their full performance potential, but the cycle life could be shortened, and in extreme cases, electrolyte leakage could cause damage to the device in which the batteries are used. It is important to consult Panasonic from the initial stages of charger design.