

LCL 12V20P

Specifications

Nominal Voltage		12V
Nominal Capacity (20 hour rate)		20.0Ah
Dimensions	Total Height	6.50inches (165mm)
	Height	6.50inches (165mm)
	Length	7.28inches (185mm)
Width	Width	4.92inches (125mm)
	Weight	Approx. 16.5lbs (7.5kg)

Characteristics

Capacity 77°F (25°C)	20 hour rate (1.0A)	20Ah
	10 hour rate (1.8A)	18Ah
	5 hour rate (3.2A)	16Ah
	1 hour rate (12.0A)	12Ah
1.5 hour discharge to 10.5V		8.2A
Internal Resistance	Full charged Battery 77°F (25°C)	9mΩ
Capacity affected by Temperature (20 hour rate)	104°F (40°C)	102%
	77°F (25°C)	100%
	32°F (0°C)	85%
	-4°F (-20°C)	60%
Self-Discharge 77°F (25°C)	Capacity after 3 month storage	91%
	Capacity after 6 month storage	82%
	Capacity after 12 month storage	64%
Terminal	M5 Bolt and Nut Type	
Charge (Constant Voltage)	Float	Initial Charging Current Less than 8.0A
		Voltage 13.6~13.8V/12V 77°F (25°C)

Note: High rate capability. Excellent for UPS application.



Unit : inch(mm)

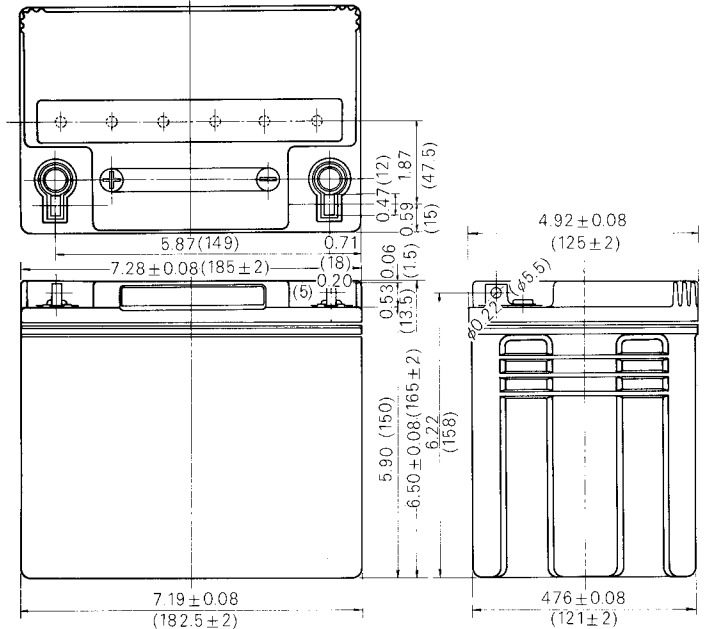

Discharging Current & Discharge Duration Time

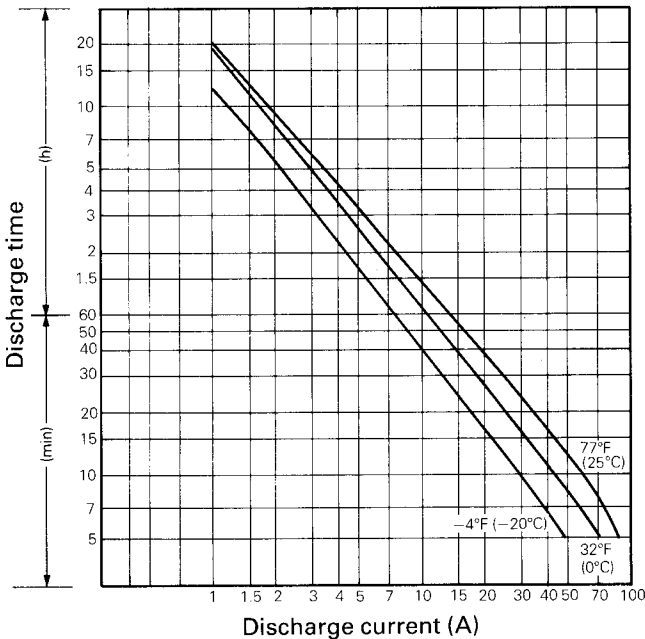

Discharge curves 77°F (25°C)

