

Panasonic Batteries

Nickel Metal Hydride

Technical Handbook '05/'06



PDF File Technical Handbook

Copyright 2005 Matsushita Battery Industrial Co., Ltd. All rights Reserved. No part of this technical handbook pdf file may be changed, altered, reproduced in any form or by any means without the prior written permission of Matsushita Battery Industrial Co., Ltd.

NOTICE TO READERS

It is the responsibility of each user to ensure that each battery application system is adequately designed safe and compatible with all conditions encountered during use, and in conformance with existing standards and requirements. Any circuits contained herein are illustrative only and each user must ensure that each circuit is safe and otherwise completely appropriate for the desired application.

This literature contains information concerning cells and batteries manufactured by Matsushita Battery Industrial Co., Ltd. This information is generally descriptive only and is not intended to make or imply any representation guarantee or warranty with respect to any cells and batteries. Cell and battery designs are subject to modification without notice. All descriptions and warranties are solely as contained in formal offers to sell or quotations made by Matsushita Battery Industrial Co., Ltd., Panasonic Sales Companies and Panasonic Agencies.

NI-MH: TABLE OF CONTENTS

ISO 9001 Approval	2
Precautions for Designing Devices with Ni-MH Batteries .	3
Ni-MH Batteries	7
• Overview	
• Construction	
• The principle of electrochemical reaction in batteries	
• Features	
• Five main characteristics	
Charge Methods for Ni-MH Batteries	12
Battery Selection	14
Specification Table	15
Individual Data Sheets	16
• Dimensions	
• Specifications	
• Characteristics	
Battery Packs	36
Transportation and Disposal Guidelines	38
Glossary of Terms for Ni-MH Batteries	39

ISO 9001 APPROVAL

ISO 9001, an international approval of quality assurance, was granted to the Alkaline Storage Battery Division of Panasonic in January 1995 for the

sealed Nickel-cadmium batteries and Nickel-metal hydride batteries produced in its factories in Japan.

- About ISO 9001

ISO 9001, which is a part of the ISO 9000 series standards of quality assurance, covers quality assurance requirements ranging from designing / developing phase to production seamlessly. ISO 9000 series is to assure buyers that quality assurance is organized and conducted efficiently at manufacturers.



PRECAUTIONS FOR DESIGNING DEVICES WITH NI-MH BATTERIES

In order to take full advantage of the properties of Ni-MH batteries and also to prevent problems due to improper use, please note the following points during the use and design of battery operated products.

Underlined sections indicate information that is especially important

1. Charging

1.1 Charging temperature

- Charge batteries within an ambient temperature range of 0°C to 40°C.
- Ambient temperature during charging affects charging efficiency. Since charging efficiency is best within a temperature range of 10°C to 30°C, whenever possible, place the charger (battery pack) in a location that is within this temperature range.
- At temperatures below 0°C the gas absorption reaction is not adequate, causing gas pressure inside the battery to rise, which can activate the safety vent and lead to leakage of alkaline gas and deterioration in battery performance.
- Charging efficiency drops at temperatures above 40°C. This can disrupt full charging and lead to deterioration in performance and battery leakage.

1.2 Parallel charging of batteries

- Sufficient care must be taken during the design of the charger when charging batteries connected in parallel. Consult Panasonic when parallel charging is required.

1.3 Reverse charging

- Never attempt reverse charging. Charging with polarity reversed can cause a reversal in battery polarity causing gas pressure inside the battery to rise, which can activate the safety vent, lead to alkaline electrolyte leakage, rapid deterioration in battery performance, battery swelling or battery rupture.

1.4 Overcharging

- Avoid overcharging. Repeated overcharging can lead to deterioration in battery performance. ("Overcharging" means charging a battery when it is already fully charged.)

1.5 Rapid charging

- To charge batteries rapidly, use the specified charger (or charging method recommended by Panasonic) and follow the correct procedures.

1.6 Trickle charging (continuous charging)

- Trickle charging cannot be used with Ni-MH batteries. However, after applying a refresh charge using a rapid charge, use a trickle charge of 0.033 CmA to 0.05 CmA. Also, to avoid overcharging with trickle charge, which could damage the cell characteristics, a timer measuring the total charge time should be used.
- Note : "CmA"
During charging and discharging, CmA is a value indicating current and expressed as a multiple of nominal capacity. Substitute "C" with the battery's nominal capacity when calculating. For example, for a 1500mAh battery of 0.033CmA, this value is equal to $1/30 \times 1500$, or roughly 50mA.

2. Discharging

2.1 Discharge temperature

- Discharge batteries within an ambient temperature range of -10°C to $+45^{\circ}\text{C}$.
- Discharge current level (i. e. the current at which a battery is discharged) affects discharging efficiency. Discharging efficiency is good within a current range of 0.1 CmA to 2 CmA.
- Discharge capacity drops at temperatures below -10°C or above $+45^{\circ}\text{C}$. Such decreases in discharge capacity can lead to deterioration in battery performance.

2.2 Overdischarge (deep discharge)

- Since overdischarging (deep discharge) damages the battery characteristics, do not forget to turn off the switch when discharging, and do not leave the battery connected to the equipment for long periods of time. Also, avoid shipping the battery installed in the equipment.

2.3 High-current discharging

- As high-current discharging can lead to heat generation and decreased discharging efficiency, consult Panasonic before attempting continuous discharging or pulse discharging at currents larger than 2 CmA.

3. Storage

3.1 Storage temperature and humidity (short-term)

- Store batteries in a dry location with low humidity, no corrosive gases, and at a temperature range of -20°C to $+45^{\circ}\text{C}$.
- Storing batteries in a location where humidity is extremely high or where temperatures fall below -20°C or rise above $+45^{\circ}\text{C}$ can lead to the rusting of metallic parts and battery leakage due to expansion or contraction in parts composed of organic materials.

3.2 Long-term storage (1 year, -20°C to $+35^{\circ}\text{C}$)

- Because long-term storage can accelerate battery self-discharge and lead to the deactivation of reactants, locations where the temperature ranges between $+10^{\circ}\text{C}$ and $+30^{\circ}\text{C}$ are suitable for long-term storage.
- When charging for the first time after long-term storage, deactivation of reactants may lead to increased battery voltage and decreased battery capacity. Restore such batteries to original performance by repeating several cycles of charging and discharging.
- When storing batteries for more than 1 year, charge at least once a year to prevent leakage and deterioration in performance due to self-discharging.

4. Service Life of Batteries

4.1 Cycle life

- Batteries used under proper conditions of charging and discharging can be used 500 cycles or more.
Significantly reduced service time in spite of proper charging means that the life of the battery has been exceeded.
Also, at the end of service life, an increase in internal resistance, or an internal short-circuit failure may occur. Chargers and charging circuits should therefore be designed to ensure safety in the event of heat generated upon battery failure at the end of service life.

4.2 Service life with long-term use

- Because batteries are chemical products involving internal chemical reactions, performance deteriorates not only with use but also during prolonged storage.
Normally, a battery will last 2 years (or 500 cycles) if used under proper conditions and not overcharged or overdischarged. However, failure to satisfy conditions concerning charging, discharging, temperature and other factors during actual use can lead to shortened life (or cycle life) damage to products and deterioration in performance due to leakage and shortened service life.

5. Design of Products Which Use Batteries

5.1 Connecting batteries and products

- Never solder a lead wire and other connecting materials directly to the battery, as doing so will damage the battery's internal safety vent, separator, and other parts made of organic materials.

To connect a battery to a product, spot-weld a tab made of nickel or nickel-plated steel to the battery's terminal strip, then solder a lead wire to the tab.

Perform soldering in as short a time as possible.

- Use caution in applying pressure to the terminals in cases where the battery pack can be separated from the equipment.

5.2 Material for terminals in products using the batteries

- Because small amounts of alkaline electrolyte can leak from the battery seal during extended use or when the safety vent is activated during improper use, a highly alkaline-resistant material should be used for a product's contact terminals in order to avoid problems due to corrosion.

High Alkaline-resistant Metals	Low Alkaline-resistant Metals
Nickel, stainless steel, nickel-plated steel, etc.	Tin, aluminum, zinc, copper, brass, etc.

(Note that stainless steel generally results in higher contact resistance.)

5.3 Temperature related the position of batteries in products

- Excessively high temperatures (i.e. higher than 45°C) can cause alkaline electrolyte to leak from the battery, thus damaging the product and shorten battery life by causing deterioration in the separator or other battery parts. Install batteries far from heat-generating parts of the product. The best battery position is in a battery compartment that is composed of an alkaline-resistant material which isolates the batteries from the product's circuitry. This prevents damage that may be caused by a slight leakage of alkaline electrolyte from the battery.

5.4 Discharge end voltage

- The discharge end voltage is determined by the formula given below. Please set the end voltage of each battery at 1.1 volts or less.

Number of Batteries Arranged Serially	
1 to 6	$(\text{Number of batteries} \times 1.0) \text{ V}$
7 to 12	$((\text{Number of batteries} - 1) \times 1.2) \text{ V}$

5.5 Overdischarge (deep discharge) prevention

- Overdischarging (deep discharging) or reverse charging damages the battery characteristics. In order to prevent damage associated with forgetting to turn off the switch or leaving the battery in the equipment for extended periods, preventative options should be incorporated in the equipment. At the same time, it is recommended that leakage current is minimized. Also, the battery should not be shipped inside the equipment.

6. Prohibited Items Regarding the Battery Handling

- Panasonic assumes no responsibility for problems resulting from batteries handled in the following manner.

6.1 Disassembly

Never disassemble a battery, as the electrolyte inside is strong alkaline and can damage skin and clothes.

6.2 Short-circuiting

Never attempt to short-circuit a battery. Doing so can damage the product and generate heat that can cause burns.

6.3 Throwing batteries into a fire or water

Disposing of a battery in fire can cause the battery to rupture. Also avoid placing batteries in water, as this causes batteries to cease to function.

6.4 Soldering

Never solder anything directly to a battery. This can destroy the safety features of the battery by damaging the safety vent inside the cap.

6.5 Inserting the batteries with their polarities reversed

Never insert a battery with the positive and negative poles reversed. as this can cause the battery to swell or rupture.

6.6 Overcharging at high currents and reverse charging

- Never reverse charge or overcharge with high currents (i.e. higher than rated). Doing so causes rapid gas generation and increased gas pressure, thus causing batteries to swell or rupture.
- Charging with an unspecified charger or specified charger that has been modified can cause batteries to swell or rupture. Be sure to indicate this safety warning clearly in all operating instructions as a handling restriction for ensuring safety.

6.7 Installation in equipment (with an airtight battery compartment)

- Always avoid designing airtight battery compartments. In some cases, gases (oxygen, hydrogen) may be given off, and there is a danger of the batteries bursting or rupturing in the presence of a source of ignition (sparks generated by a motor switch, etc.).

6.8 Use of batteries for other purposes

- Do not use a battery in an appliance or purpose for which it was not intended. Differences in specifications can damage the battery or appliance.

6.9 Short-circuiting of battery packs

- Special caution is required to prevent short-circuits.
Care must be taken during the design of the battery pack shape to ensure batteries cannot be inserted in reverse. Also, caution must be given to certain structures or product terminal shapes which can make short-circuiting more likely.

6.10 Using old and new batteries together

- Avoid using old and new batteries together. Also avoid using these batteries with ordinary dry-cell batteries, Ni-Cd batteries or with another manufacturer's batteries.
Differences in various characteristic values, etc., can cause damage to batteries or the product.

7. Other Precautions

- Batteries should always be charged prior to use. Be sure to charge correctly.

8. Final Point to Bear in Mind

- In order to ensure safe battery use and to prolong the battery performance, please consult Panasonic regarding charge and discharge conditions for use and product design prior to the release of a battery-operated product.

NICKEL METAL HYDRIDE BATTERIES

High-energy Batteries to Launch a New Era of Products



Overview

As electronic products have come to feature more sophisticated functions, more compact sizes and lighter weights, the sources of power that operate these products have been required to deliver increasingly higher levels of energy. To meet this requirement, nickel-metal hydride batteries have been developed and manufactured with nickel hydroxide for the positive electrode and hydrogen-absorbing alloys, capable of absorbing and releasing hydrogen at high-density levels, for the negative electrode. Because Ni-MH batteries have about twice the energy density of Ni-Cd batteries and a similar operating voltage as that of Ni-Cd batteries, they have become a mainstay in rechargeable batteries.

Construction

Nickel-metal hydride batteries consist of a positive plate containing nickel hydroxide as its principal active material, a negative plate mainly composed of hydrogen-absorbing alloys, a separator made of fine fibers, an alkaline electrolyte, a metal case and a sealing plate provided with a self-resealing safety vent. Their basic structure is identical to that of Ni-Cd batteries. With cylindrical nickel-metal hydride batteries, the positive and negative plates are separated by the separator, wound into a coil, inserted into the case, and sealed by the sealing plate through an electrically insulated gasket.

Structure of Nickel-Metal Hydride Batteries

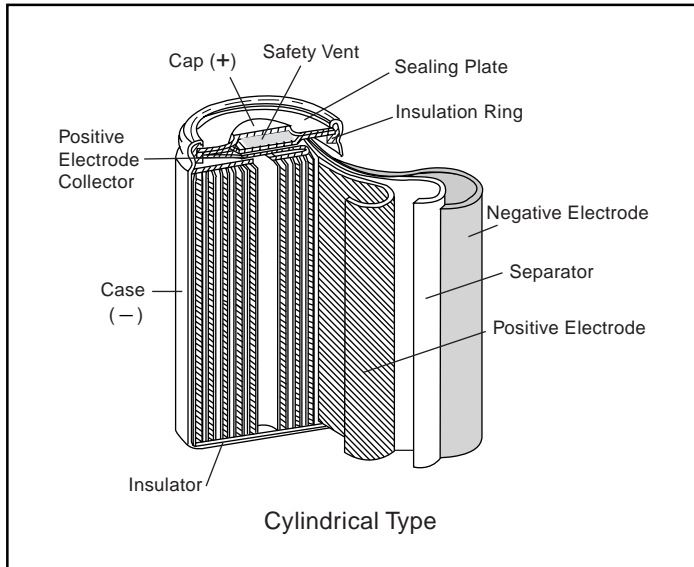

Hydrogen-absorbing Alloys

Hydrogen-absorbing alloys have a comparatively short history which dates back about 20 years to the discovery of NiFe, MgNi and LaNi₅ alloys. They are capable of absorbing hydrogen equivalent to about a thousand times of their own volume, generating metal hydrides and also of releasing the hydrogen that they absorbed. These hydrogen-absorbing alloys combine metal (A) whose hydrides generate heat exothermically with metal (B) whose hydrides generate heat endothermically to produce the suitable binding energy so that hydrogen can be absorbed and released at or around normal temperature and pressure levels. Depending on how metals A and B are combined, the alloys are classified into the following types: AB (TiFe, etc.), AB₂ (ZnMn₂, etc.), AB₅ (LaNi₅, etc.) and A₂B (Mg₂Ni, etc.). From the perspective of charge and discharge efficiency and durability, the field of candidate metals suited for use as electrodes in storage batteries is now being narrowed down to AB₅ type alloys in which rare-earth metals, especially metals in the lanthanum group, and nickel serve as the host metals; and to AB₂ type alloys in which the titanium and nickel serve as the host metals.

Panasonic is now focusing its attention on AB₅ type alloys which feature high capacity, excellent charge and discharge efficiency, and excellent cycle life. It has developed, and is now employing its own MmNi₅ alloy which uses Mm (misch metal = an alloy consisting of a mixture of rare-earth elements) for metal A.

Principle of Electrochemical Reaction Involved in Batteries

Nickel-metal hydride batteries employ nickel hydroxide for the positive electrode similar to Ni-Cd batteries. The hydrogen is stored in a hydrogen-absorbing alloy for the negative electrode, and an aqueous solution consisting mainly of potassium hydroxide for the electrolyte. Their charge and discharge reactions are shown below.

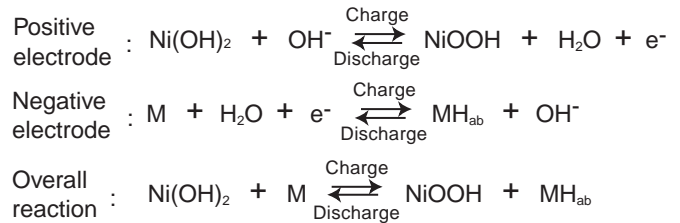

(M: hydrogen-absorbing alloy; H_{ab}: absorbed hydrogen)

As can be seen by the overall reaction given above, the chief characteristics of the principle behind a nickel-metal hydride battery is that hydrogen moves from the positive to negative electrode during charge and reverse during discharge, with the electrolyte taking no part in the reaction; which means that there is no accompanying increase or decrease in the electrolyte. A model of this battery's charge and discharge mechanism is shown in the figure below. These are the useful reactions taking place at the respective boundary faces of the positive and negative electrodes, and to assist one in understanding the principle, the figure shows how the reactions proceed by the transfer of protons (H⁺).

The hydrogen-absorbing alloy negative electrode successfully reduces the gaseous oxygen given off from the positive electrode during overcharge by sufficiently increasing the capacity of the negative electrode which is the same method employed by Ni-Cd batteries. By keeping the battery's internal pressure constant in this manner, it is possible to seal the battery.

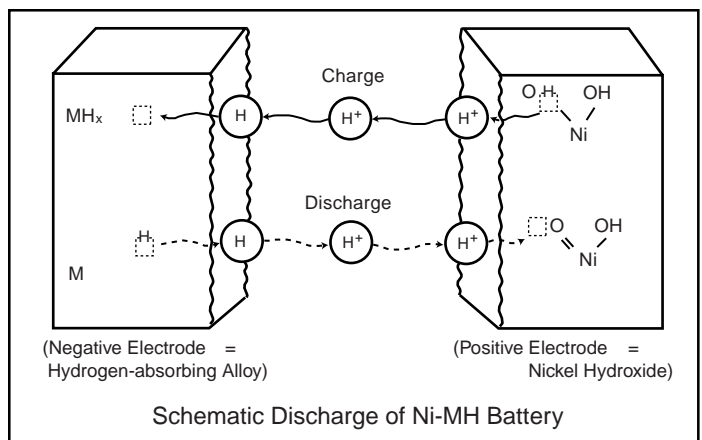

NICKEL METAL HYDRIDE BATTERIES - CONTINUED

Features

- **Similarity with Ni-Cd batteries**

These batteries have similar discharge characteristics to those of Ni-Cd batteries.

- **Double the energy density of conventional batteries**

Nickel-metal hydride batteries have approximately double the capacity compared with Panasonic's standard Ni-Cd batteries.

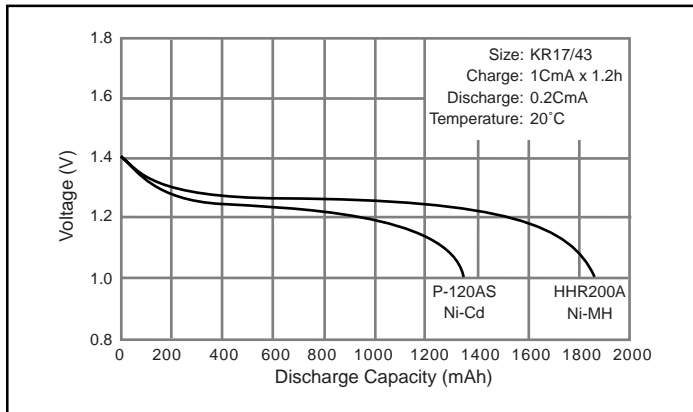

- **Cycle life equivalent to 500 charge and discharge cycles**

Like Ni-Cd batteries, nickel-metal hydride batteries can be repeatedly charged and discharged for about 500 cycles. (example: IEC charge and discharge conditions)

- **Rapid charge in approx. 1 hour**

Nickel-metal hydride batteries can be rapidly charged in about an hour using a specially designed charger.

- **Excellent discharge characteristics**

Since the internal resistance of nickel-metal hydride batteries is low, continuous high-rate discharge up to 3CmA is possible, similar to Ni-Cd batteries.

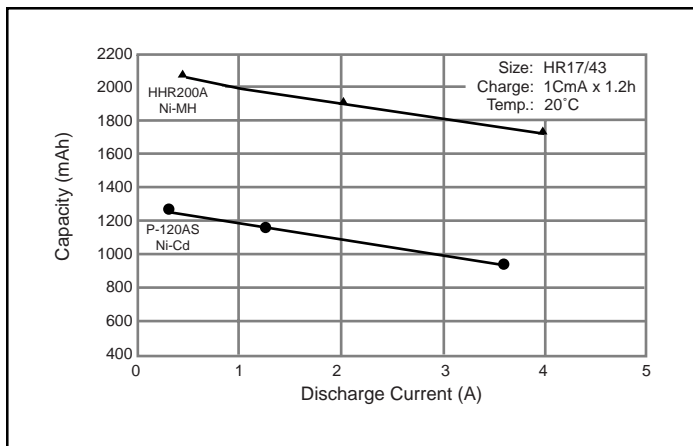

Five Main Characteristics

As with Ni-Cd batteries, nickel-metal hydride batteries have five main characteristics: charge, discharge, storage life, cycle life and safety.

1) Charge characteristics

Like Ni-Cd batteries, the charge characteristics of nickel-metal hydride batteries are affected by current, time and temperature. The battery voltage rises when the charge current is increased or when the temperature is low. The charge efficiency differs depending on the current, time, temperature and other factors.

Nickel-metal hydride batteries should be charged at a temperature ranging from 0°C to 40°C using a constant current of 1It or less. The charge efficiency is particularly good at a temperature of 10°C to 30°C. Repeated charge at high or low temperatures causes the battery performance to deteriorate. Furthermore, repeated overcharge should be avoided since it will downgrade the battery performance.

Refer to the section on recommended charge methods for details on how to charge the batteries.

- Charge characteristics

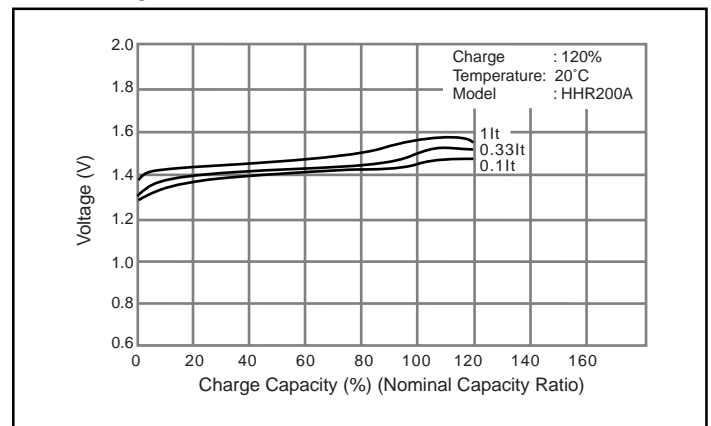

- Charge temperature characteristics at 1It charge

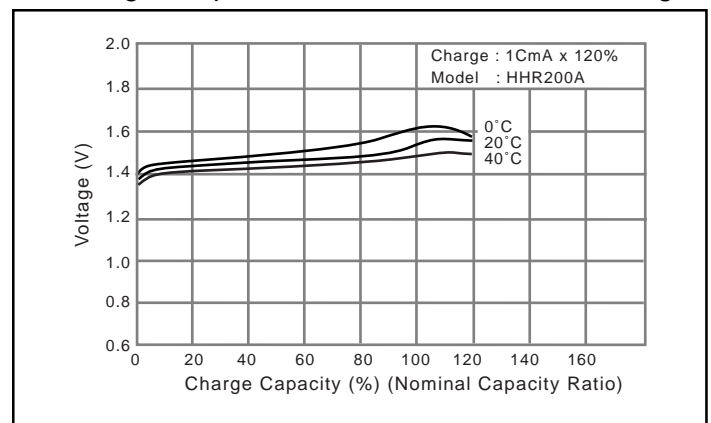

NICKEL METAL HYDRIDE BATTERIES - CONTINUED

- Charge temperature characteristics at various charge rates

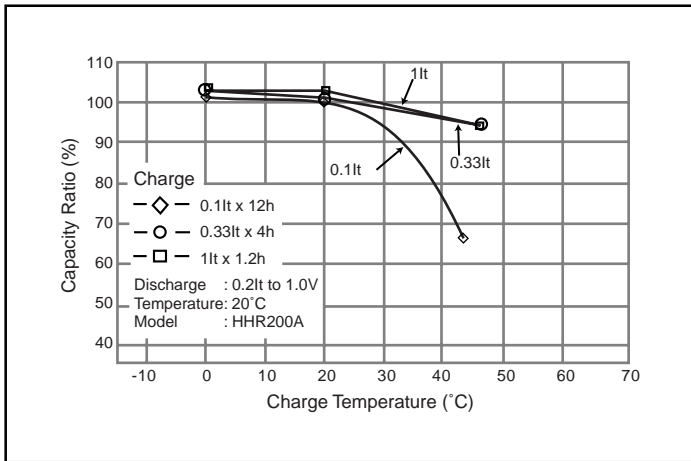

- Discharge temperature characteristics at 1lt discharge

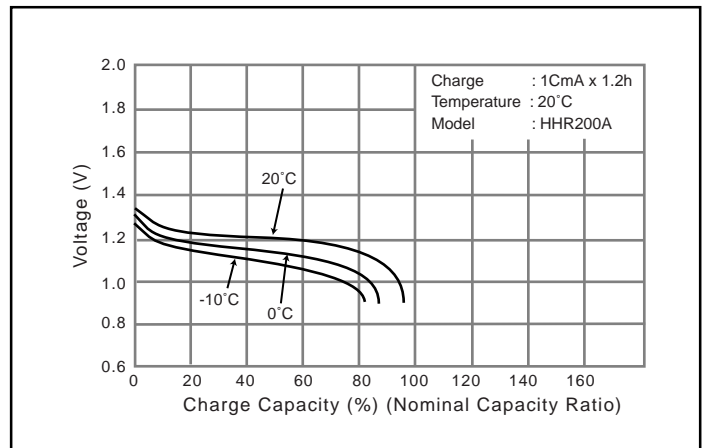

2) Discharge characteristics

The discharge characteristics of nickel-metal hydride batteries are affected by current, temperature, etc., and the discharge voltage characteristics are flat at 1.2V, which is almost the same as for Ni-Cd batteries. The discharge voltage and discharge efficiency decrease in proportion as the current rises or the temperature drops. Compared with Ni-Cd batteries, nickel-metal hydride batteries have inferior high-rate discharge characteristics, making them less suitable for use in applications requiring high-current discharge. As with Ni-Cd batteries, repeated charge and discharge of these batteries under high discharge cut-off voltage conditions (more than 1.1V per cell) causes a drop in the discharge voltage (which is sometimes accompanied by a simultaneous drop in capacity). The discharge characteristics can be restored by charge and discharge to a discharge end voltage of down to 1.0V per cell.

- Discharge temperature characteristics

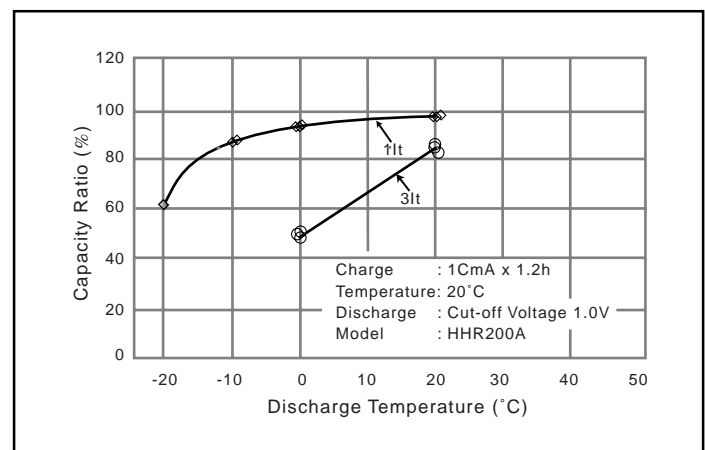

3) Storage characteristics

These characteristics include self-discharge characteristics and restoration characteristics after long-term storage. When batteries are left standing, their capacity generally drops due to self-discharge, but this is restored by charge.

- Discharge characteristics

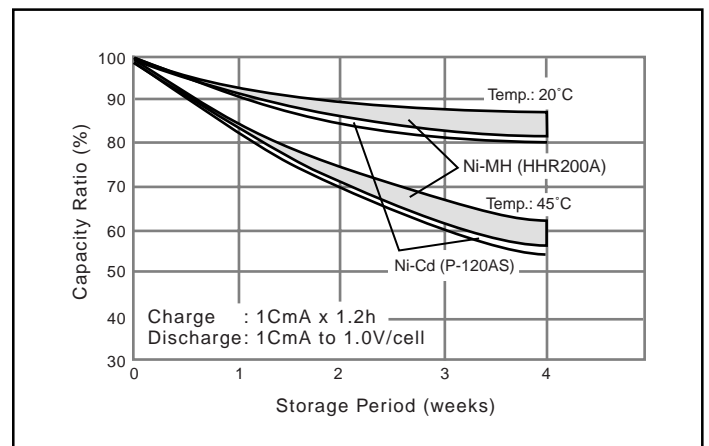
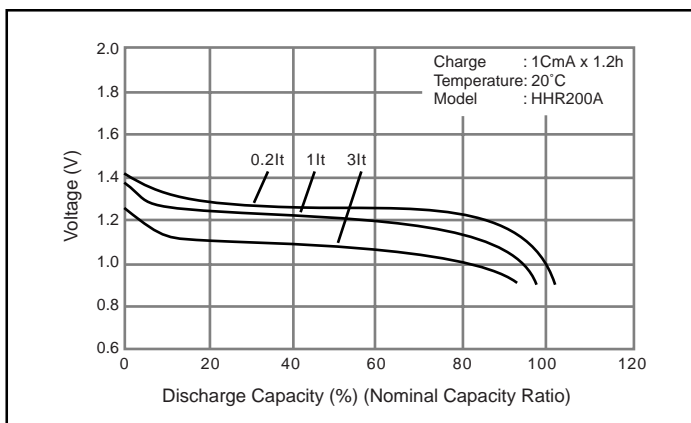

NICKEL METAL HYDRIDE BATTERIES - CONTINUED

- Self discharge characteristics

Self-discharge is affected by the temperature at which the batteries are left standing and the length of time during which they are left standing. It increases in proportion as the temperature or the shelf-standing time increases. Panasonic's nickel-metal hydride batteries have excellent self-discharge characteristics that are comparable to those of Ni-Cd batteries.

4) Cycle Life Characteristics

The cycle life of these batteries is governed by the conditions under which they are charged and discharged, temperature and other conditions of use. Under proper conditions of use (example: IEC charge and discharge conditions), these batteries can be charged and discharged for more than 500 cycles.

- Cycle life characteristics

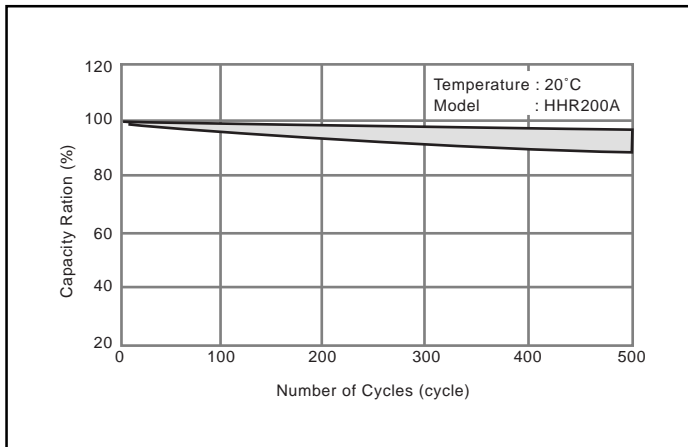

5) Safety

When the internal pressure of these batteries rises due to overcharge, short-circuiting, reverse charge or other abuse or misuse, the self-resealing safety vent is activated to prevent battery damage. Panasonic's nickel-metal hydride batteries have similar safety characteristics as Panasonic Ni-Cd batteries.

CHARGE METHODS FOR NICKEL METAL HYDRIDE BATTERIES

Charge is the process of restoring a discharged battery to its original capacity. In order for a battery to be usable for a long period of time, it must be charged via the proper charge method. Various methods are used to charge rechargeable cells, but Panasonic recommends the charge methods described below to charge its nickel-metal hydride batteries.

- (1) Rapid charge current: 1CmA (rapid charge temperature range: 0°C to 40°C). In order to exercise proper control to stop rapid charge, it is recommended that batteries be charged at over 0.5CmA but less than 1CmA. Charging batteries at a current in excess of 1CmA may cause the safety vent to be activated by a rise in the internal pressure of the batteries, thereby resulting in electrolyte leakage. When the temperature of the batteries is detected by a thermistor or other type of sensor, and their temperature is under 0°C or over 40°C at the commencement of the charge, then trickle charge, rather than rapid charge, must be performed. Rapid charge is stopped when any one of the values among the types of control described in (4), (5), (6), and (11) reaches the prescribed level.
- (2) Allowing a high current to flow to excessively discharged or deep-discharged batteries during charge may make it impossible to sufficiently restore the capacity of the batteries. To charge excessively discharged or deep-discharged batteries, first allow a trickle current to flow, and then proceed with the rapid charge current once the battery voltage has risen.
- (3) Rapid charge start voltage: Approx. 0.8V/cell
Rapid charge transition voltage restoration current: 0.2 ~ 0.3 CmA
- (4) Upper battery voltage limit control: Approx. 1.8V/cell. The charge method is switched over to trickle if the battery voltage reaches approximately 1.8V/cell due to trouble or malfunctioning of some kind.
- (5) ΔV value: 5 to 10mV/cell. When the battery voltage drops from its peak to 5 to 10mV/cell during rapid charge, rapid charge is stopped, and the charge method is switched over to trickle charge.
- (6) dT/dt value: Approx. 1 to 2°C/min. When a rise in the battery temperature per unit time is detected by a thermistor or other type of temperature sensor during rapid charge, and the prescribed temperature rise is sensed, rapid charge is stopped and the charge method is switched over to trickle charge.

- (7) TCO: 55°C (for A, AA and D sizes), 50°C (for AAA size), 60°C (for L-A, L-fatA and SC sizes). The cycle life and other characteristics of batteries are impaired if the batteries are allowed to become too hot during charge. In order to safeguard against this, rapid charge is stopped and the charge method is switched over to trickle charge when the battery temperature has reached the prescribed level.
- (8) Initial delay timer: to 10 min. This prevents the $-\Delta V$ detection circuit from being activated for a specific period of time after rapid charge has commenced. However, the dT/dt detection circuit is allowed to be activated during this time. As with Ni-Cd batteries, the charge voltage of nickel-metal hydride batteries may show signs of swinging (pseudo $-\Delta V$) when they have been kept standing for a long time or when they have discharged excessively, etc. The initial delay timer is needed to prevent charge from stopping (to prevent malfunctioning) due to this pseudo $-\Delta V$.
- (9) Trickle current: 0.033 to 0.05CmA. When the trickle current is set higher, the temperature rise of the batteries is increased, causing the battery characteristics to deteriorate.
- (10) Rapid charge transfer timer: 60 min.
- (11) Rapid charge timer: 90 min. (at 1It charge)
- (12) Total timer: 10 to 20 hours.
The overcharging of nickel-metal hydride batteries, even by trickle charging, causes a deterioration in the characteristics of the batteries. To prevent overcharging by trickle charging or any other charging method, the provision of a timer to regulate the total charging time is recommended.

Note: The temperature and voltage of nickel-metal hydride batteries varies depending on the shape of the battery pack, the number of cells, the arrangement of the cells and other factors. Therefore Panasonic should be consulted for more detailed information on the referenced charge control values. The charge methods described previously can be applied also when both nickel-metal hydride batteries and Ni-Cd batteries are employed in a product, but Panasonic should be consulted for the control figures and other details.

CHARGE METHODS FOR NICKEL METAL HYDRIDE BATTERIES - CONTINUED

- Recommended nickel-metal hydride battery charge system*

(1)	Rapid charge current	Max. 1CmA to 0.5CmA
(2)	Rapid charge transition voltage restoration current	0.2 to 0.3CmA
(3)	Rapid charge start voltage	Approx. 0.8V/cell
(4)	Charge terminating voltage	1.8V/cel
(5)	-ΔV value	5 to 10mV/cell
(6)	Battery temperature rising rate dT/dt value	1 to 2°C/min.
(7)	Maximum battery temperature TCO	60°C (for L-A, L-fatA and SC sizes) 55°C (A, AA and D sizes) 50°C (for AAA size)
(8)	Initial -ΔV detection disabling timer	5 to 10 min.
(9)	Trickle current (after rapid charge)	0.033 to 0.05CmA
(10)	Rapid charge transfer timer	60 min
(11)	Rapid charge timer	90 min (at 1CmA charge)
(12)	Total timer	10 to 20 hours
(13)	Rapid charge temperature range	0 to 40°C

- * Matching test is required because these values vary depending on rapid charge current, number of cells, configuration of battery pack, etc.

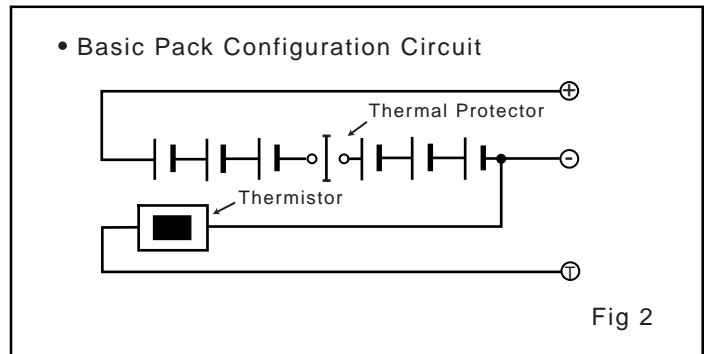
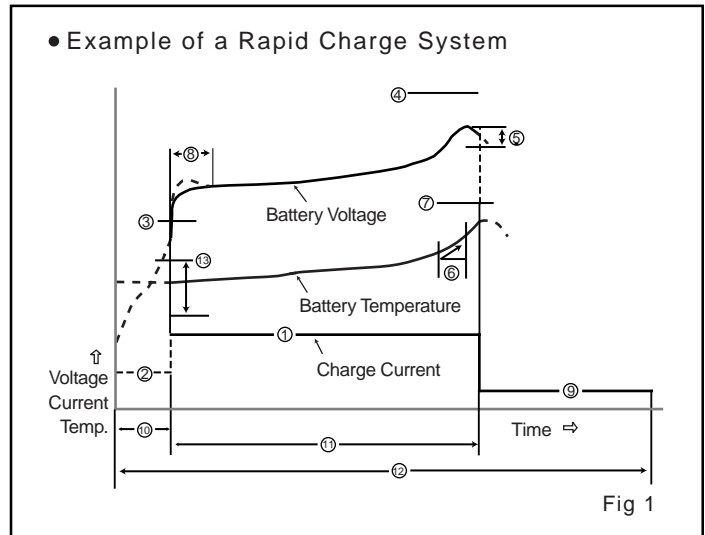

NiMH "H" Series Recommended Charge System for back-up power applications (Applies to HHR60AAAH, HHR210AH, HHR370AH, HHR250SCH, & HHR300CH Cylindrical cells)

The optimal charge system for the NiMH "H" Series for back-up power applications is an intermittent timer charge. An intermittent timer charge improves charge efficiency, extends battery life (-vs- trickle charge) and reduces electricity consumption up to 30% compared to trickle* charge.

Intermittent Timer Charge: (see diagram)
At the beginning of the charge, an IC timer is started and charging is activated at a current of 0.1It until the timer stops and the charge is terminated. When the batteries self discharge down to a set point (1.3V), the timer charge is re-activated.

*Trickle charge is not recommended for NiMH batteries. Please consult Panasonic on any NiMH applications requiring trickle charge.

- Example of intermittent timer charger system:
Average Charge Current: 0.1 ItA
Re-charge time: 16 hours
Pulse charging can be used

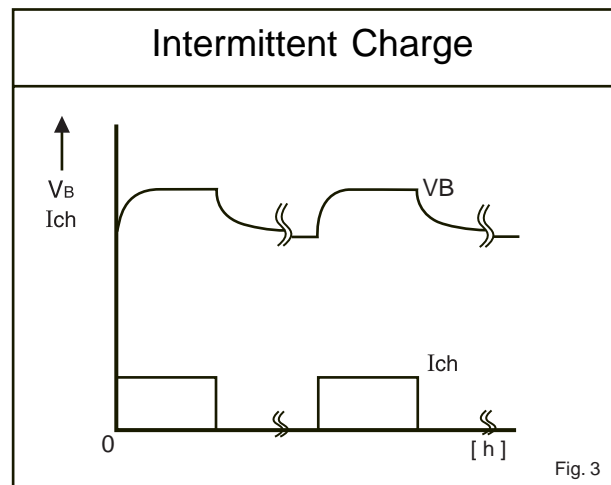

BATTERY SELECTION

The steps for selecting a type of battery for use as the power supply of a device are shown below:

Study of the Proposed Required Specifications

Verify the battery specifications required for the power supply of the device and use those conditions as the standards for battery selection. For reference, the technological factors concerning battery selection are shown below.

Battery Selection

Using the catalogs and data sheets for the batteries currently produced and marketed, narrow down the number of candidates to a few battery types. From those

candidates, select the one battery that most closely satisfies the ideal conditions required. In actual practice, the selection of a battery is rarely completed as easily as this. In most cases it is necessary to consider eliminating or relaxing some of the proposed specifications, and then select the most suitable battery from among those currently available to meet the adjusted conditions. This process makes it possible to select more economical batteries. If you have any doubts at this stage, consult closely with a battery engineer. In some cases, newly improved or newly developed batteries that are not yet listed in the catalog may be available. Normally the required specifications are also finalized at this stage.

Technological Factors Concerning Battery Selection

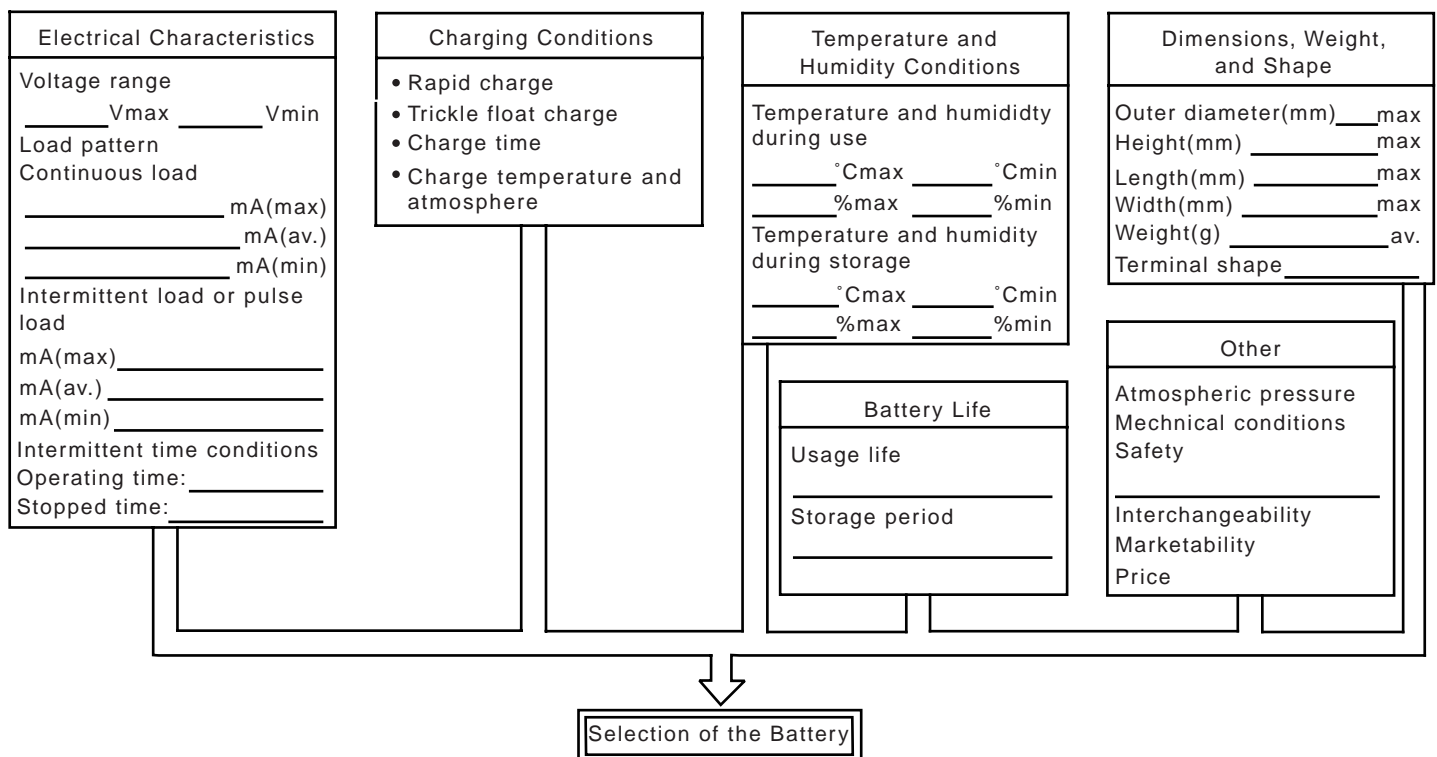

SPECIFICATION TABLE

Cylindrical

Diameter	Size	IEC	Model Number	Nominal Voltage (V)	Discharge Capacity ^{*5} (mAh)		Dimensions with Tube (mm)		Approx. Weight (g)	Page
					Average ^{*4}	Rated (Min.)	Diameter	Height		
AAA	AAA	HR11/45	HHR60AAAH ^{*1}	1.2	550	500	10.5+0/-0.7	44.5+0/-1.0	13	16
			HHR75AAA/B		730	700			12	17
			HHR70AAA/J		720	700			13	18
4/5AA	HR15/43	HHR120AA	1220		1150	14.5+0/-0.7	43.0+0/-1.0	23	19	
		HHR150AA	1580		1500			26	20	
AA	AA	HR15/51	HHR210AA/B		2080	2000	17.0+0/-0.7	50.5+0/-1.0	29	21
			HHR200A		2040	2000			32	22
A	4/5A	HR17/43	HHR210AH ^{*1}		2050	1900	17.0+0/-0.7	50.0+0/-1.5	38	23
	A	HR17/50	HHR210A		2200	2100			38	24
			L-A		HR17/67	HHR380A ^{*2}			3800	3700
fat A	L-fat A (18670)	HR18/67	HHR330APH		3300	3200	18.2+0/-0.7	67.0+0/-1.5	60	26
			HHR370AH ^{*1}		3700	3500			60	27
			HHR450A ^{*2}	4500	4200	60			28	
SC	4/5SC	HR23/34	HHR200SCP ^{*3}	2100	1900	23.0+0/-1.0	34.0+0/-1.5	42	29	
	SC	HR23/43	HHR250SCH ^{*1}	2650	2500			43.0+0/-1.5	55	30
			HHR260SCP ^{*3}	2600	2450				55	31
			HHR300SCP ^{*3}	3050	2800				57	32
C	C	HR26/50	HHR300CH ^{*1}	3300	3100	25.8+0/-1.0	50.0+0/-1.5	80	33	
D	D	HR33/62	HHR650D ^{*3}	6800	6500	33.0+0/-1.0	60.8+0/-2.0	170	34	
			HHR900D ^{*3}	9000	8250			165	35	

NOTE: /B = Extended positive terminal (Button Top)

*1 H Type: Improved low rate charge characteristics at higher temperatures. Ideal for back-up applications (with appropriate charge control circuitry).

*2 Mainly for PC applications.

*3 Mainly for High Drain applications.

*4 For reference only.

*5 After charging at 0.1It for 16 hours, discharging at 0.2It.

Battery performance and cycle life are strongly affected by how they are used. In order to maximize battery safety, please consult Panasonic when determining charge / discharge specs, warning label contents and unit design.

Note: [It] was previously expressed as [C]. [It] is an IEC standard expression for the amount of charge or discharge current and is expressed as: It(A) = Cn (Ah)/1h.

- [It] is the reference test current in amperes
- [Cn] is the rated capacity of the cell or battery in Ampere-hours.
- n = the time base [hours] for which the rated capacity is declared

NICKEL METAL HYDRIDE BATTERIES: INDIVIDUAL DATA SHEET

HHR60AAAH Cylindrical AAA size (HR 11/45)

Dimensions (with Tube) (mm)

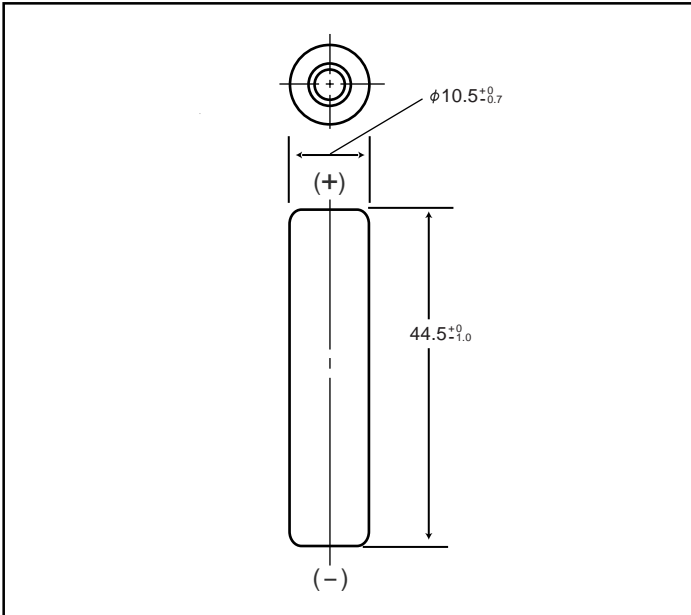

Specifications

	mm	inch
Diameter	10.5 +0/-0.7	0.41 +0/-0.03
Height	44.5 +0/-1.0	1.75 +0/-0.04
Approximate Weight	Grams	Ounces
	13	0.46

Nominal Voltage		1.2V	
Discharge Capacity ¹	Average ²	550 mAh	
	Rated (Min.)	500 mAh	
Approx. Internal impedance at 1000Hz at charged state.		35mΩ	
Charge	Standard	50mA x 16hrs.	
	Rapid ³	250mA x 2.4 hrs. ⁴	
	Low Rate	25mA x 32 hrs. 17mA x 48 hrs.	
Ambient Temperature	Charge	Standard	°C: -10°C to 60°C °F: 14°F to 140°F
		Rapid	°C: -10°C to 45°C °F: 14°F to 113°F
Storage	Discharge		°C: -10°C to 60°C °F: 14°F to 140°F
	< 1 year	< 6 months	°C: -20°C to 35°C °F: -4°F to 95°F
		< 1 month	°C: -20°C to 45°C °F: -4°F to 113°F
		< 1 month	°C: -20°C to 55°C °F: -4°F to 131°F
		< 1 week	°C: -20°C to 65°C °F: -4°F to 149°F

¹ After charging at 0.1It for 16 hours, discharging at 0.2It.

² For reference only.

³ Need specially designed control system

Control System:

dT/dt cut-off; 1 to 2°C/min

-ΔV cut-off; -ΔV per cell = 5 to 10 mV

T-control; T=65°C

Rapid charger timer; 2.4h (at 1.25a)

Trickle timer; within 2h

⁴ With control system

Battery performance and cycle life are strongly affected by how they are used. In order to maximize battery safety, please consult Panasonic when determining charge / discharge specs, warning label contents and unit design.

Typical Charge Characteristics

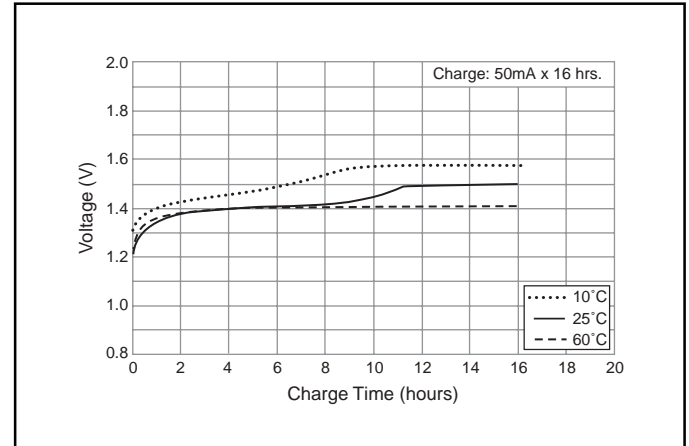

Typical Discharge Characteristics

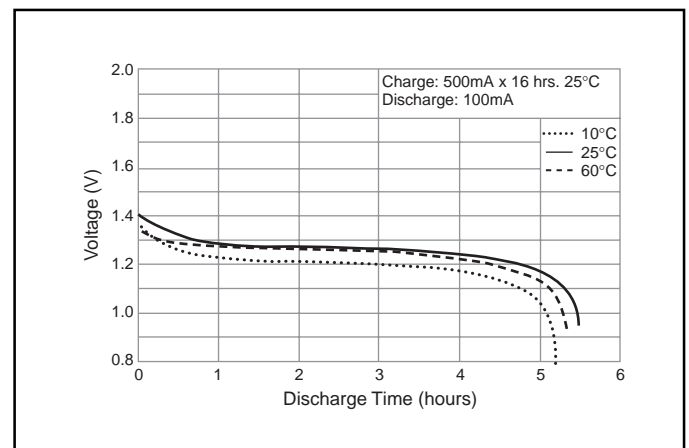
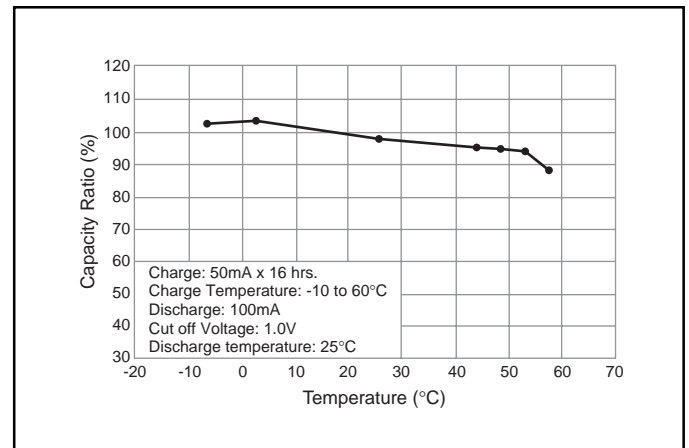

Note: [It] was previously expressed as [C]. [It] is an IEC standard expression for the amount of charge or discharge current and is expressed as:

$$It(A) = Cn (Ah)/1h$$

* [It] is the reference test current in amperes

* [Cn] is the rated capacity of the cell or battery in Ampere-hours.

n = the time base [hours] for which the rated capacity is declared

NICKEL METAL HYDRIDE BATTERIES: INDIVIDUAL DATA SHEET

HHR75AAA/B Cylindrical AAA size (HR 11/45)

Dimensions (with Tube) (mm)

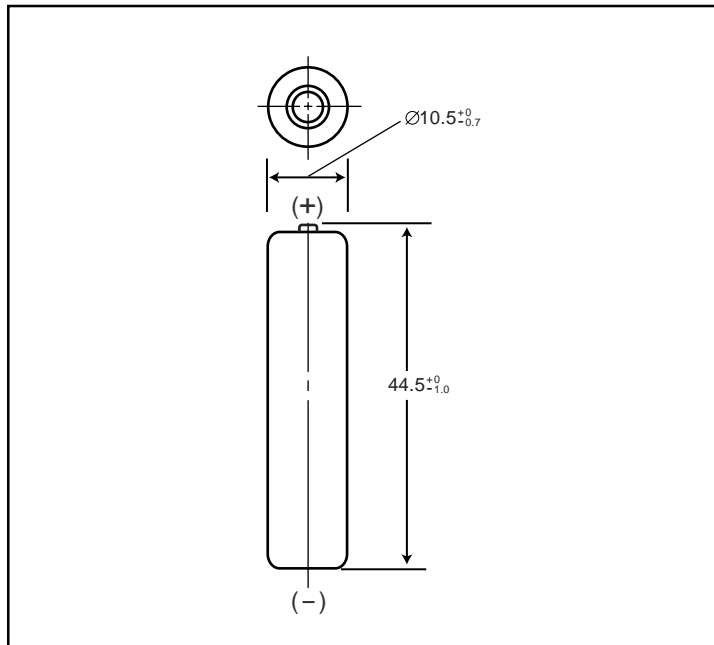

Specifications

	mm	inch
Diameter	10.5+0/-0.7	0.41+0/-0.03
Height	44.5+0/-1.0	1.75+0/-0.04
Approximate Weight	Grams	Ounces
	12	0.42

Nominal Voltage		1.2V		
Discharge Capacity*	Average**	730 mAh		
	Rated (Min.)	700 mAh		
Approx. Internal impedance at 1000Hz at charged state.		35mΩ		
Charge	Standard	70mA x 16hrs.		
	Rapid	450mA x 1.7 hrs.		
Ambient Temperature	Charge	Standard	°C	°F
			0°C to 45°C	32°F to 113°F
	Rapid	0°C to 40°C	32°F to 104°F	
		Discharge		-10°C to 65°C
Storage	< 1 year	-20°C to 35°C	-4°F to 95°F	
	< 3 months	-20°C to 45°C	-4°F to 113°F	
	< 1 month	-20°C to 55°C	-4°F to 131°F	

* After charging at 0.1It for 16 hours, discharging at 0.2It.

** For reference only.

Battery performance and cycle life are strongly affected by how they are used. In order to maximize battery safety, please consult Panasonic when determining charge / discharge specs, warning label contents and unit design.

Note: [It] was previously expressed as [C]. [It] is an IEC standard expression for the amount of charge or discharge current and is expressed as:
 $It(A) = C_n (Ah)/1h.$

- [It] is the reference test current in amperes
- [Cn] is the rated capacity of the cell or battery in Ampere-hours.
- n = the time base [hours] for which the rated capacity is declared

Typical Charge Characteristics

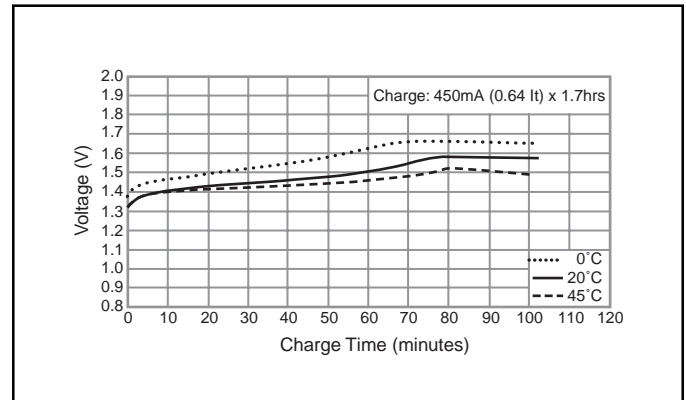

Typical Discharge Characteristics

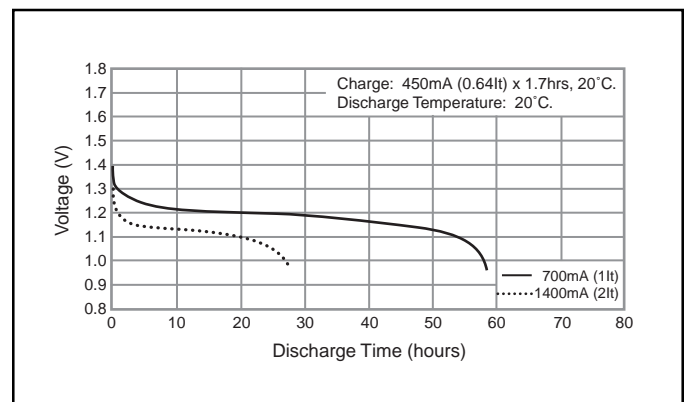
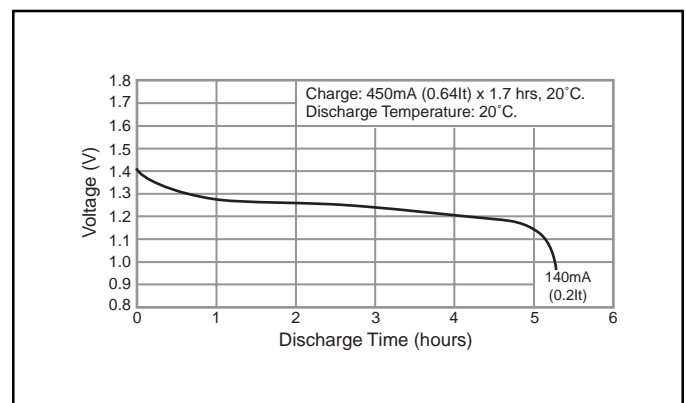

NICKEL METAL HYDRIDE BATTERIES: INDIVIDUAL DATA SHEET

HHR70AAAJ Cylindrical HR AAA size (HR 11/45)

Dimensions (with Tube) (mm)

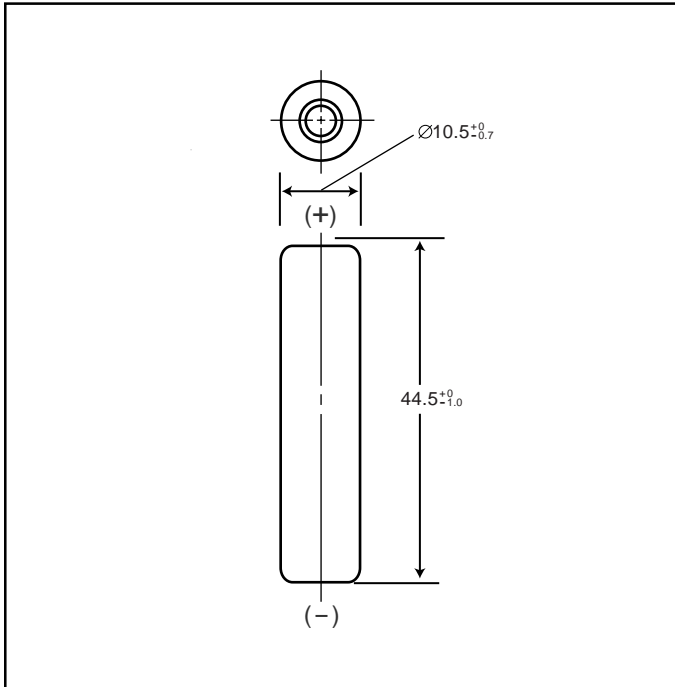

Specifications

	mm	inch
Diameter	10.5+0/-0.7	0.41+0/-0.03
Height	44.5+0/-1.0	1.75+0/-0.04
Approximate Weight	Grams	Ounces
	13	0.46

Nominal Voltage		1.2V		
Discharge Capacity*	Average**	720 mAh		
	Rated (Min.)	700 mAh		
Approx. Internal impedance at 1000Hz at charged state.		30mΩ		
Charge	Standard	70mA (0.1It) x 16hrs.		
	Rapid	650mA (1It) x 1.2 hrs.		
Ambient Temperature	Charge	Standard	°C	°F
			0°C to 45°C	32°F to 113°F
	Rapid	0°C to 40°C	32°F to 104°F	
		Discharge	-10°C to 65°C	14°F to 149°F
Storage	< 1 year	-20°C to 35°C	-4°F to 95°F	
	< 3 months	-20°C to 45°C	-4°F to 113°F	
	< 1 month	-20°C to 55°C	-4°F to 131°F	

* After charging at 0.1It for 16 hours, discharging at 0.2It.

** For reference only.

Battery performance and cycle life are strongly affected by how they are used. In order to maximize battery safety, please consult Panasonic when determining charge / discharge specs, warning label contents and unit design.

Note: [It] was previously expressed as [C]. [It] is an IEC standard expression for the amount of charge or discharge current and is expressed as:

$$It(A) = C_n (Ah)/1h.$$

- [It] is the reference test current in amperes
- [C_n] is the rated capacity of the cell or battery in Ampere-hours.
n = the time base [hours] for which the rated capacity is declared

Typical Charge Characteristics

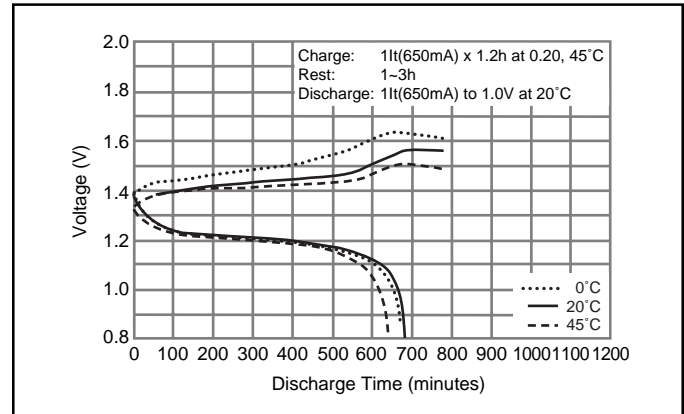

Typical Discharge Characteristics

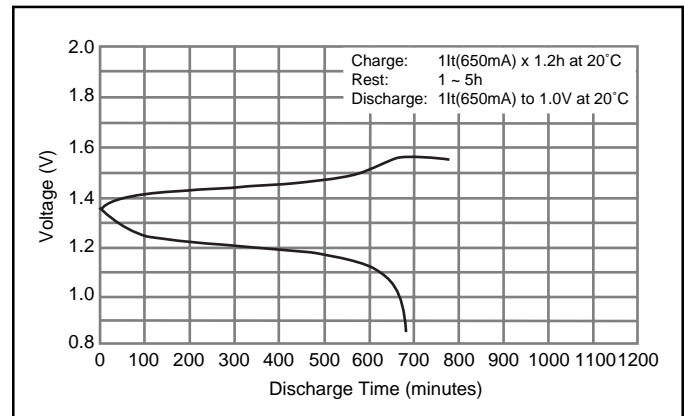
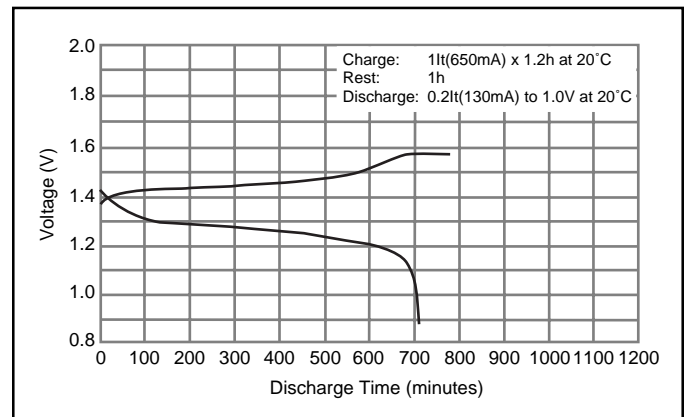

NICKEL METAL HYDRIDE BATTERIES: INDIVIDUAL DATA SHEET

HHR120AA Cylindrical 4/5AA size (HR 15/43)

Dimensions (with Tube) (mm)

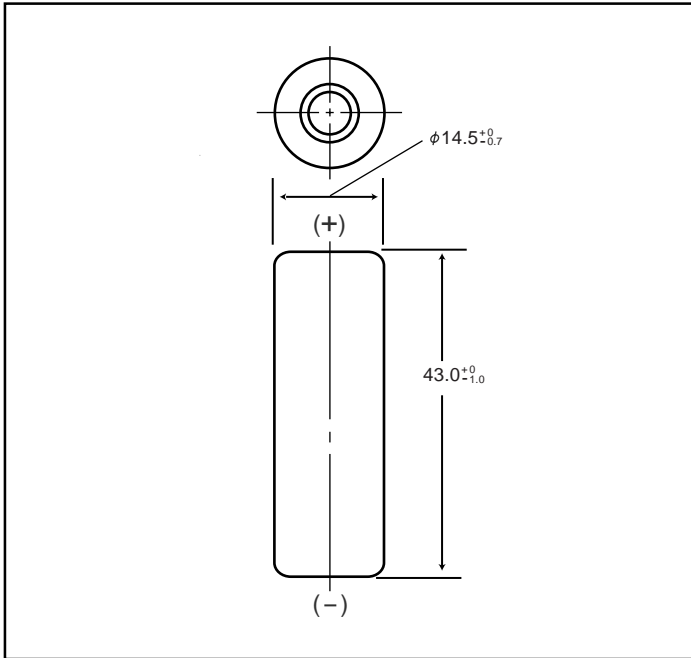

Specifications

	mm	inch
Diameter	14.5+0/-0.7	0.57+0/-0.03
Height	43.0+0/-1.0	1.69+0/-0.04
Approximate Weight	Grams	Ounces
	23	0.81

Nominal Voltage		1.2V		
Discharge Capacity*	Average**	1220 mAh		
	Rated (Min.)	1150 mAh		
Approx. Internal impedance at 1000Hz at charged state.		19mΩ		
Charge	Standard	120mA (0.1It) x 16hrs.		
	Rapid	1200mA (1It) x 1.2 hrs.		
Ambient Temperature	Charge	Standard	°C	
			°F	
	Discharge	Standard	0°C to 45°C	32°F to 113°F
		Rapid	0°C to 40°C	32°F to 104°F
Storage	< 1 year	-20°C to 35°C	-4°F to 95°F	
	< 3 months	-20°C to 45°C	-4°F to 113°F	
	< 1 month	-20°C to 55°C	-4°F to 131°F	

* After charging at 0.1It for 16 hours, discharging at 0.2It.

** For reference only.

Battery performance and cycle life are strongly affected by how they are used. In order to maximize battery safety, please consult Panasonic when determining charge / discharge specs, warning label contents and unit design.

Note: [It] was previously expressed as [C]. [It] is an IEC standard expression for the amount of charge or discharge current and is expressed as:
It(A) = Cn (Ah)/1h.

- [It] is the reference test current in amperes
- [Cn] is the rated capacity of the cell or battery in Ampere-hours.
- n = the time base [hours] for which the rated capacity is declared

Typical Charge Characteristics

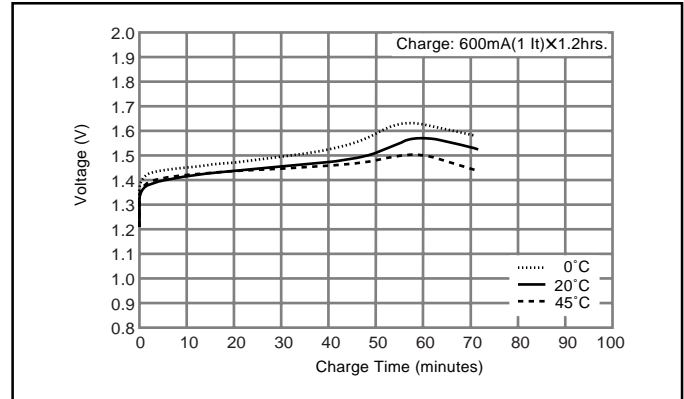

Typical Discharge Characteristics

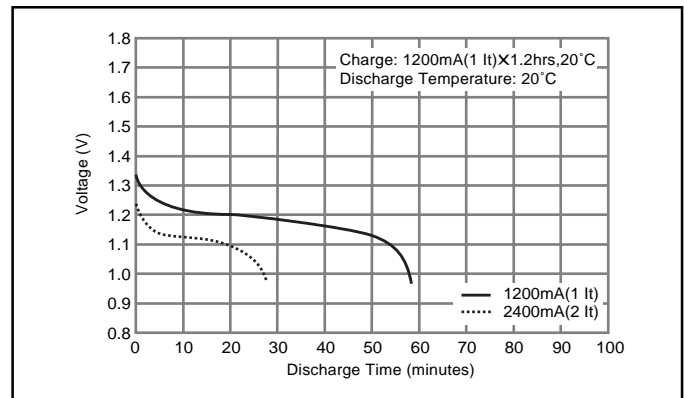
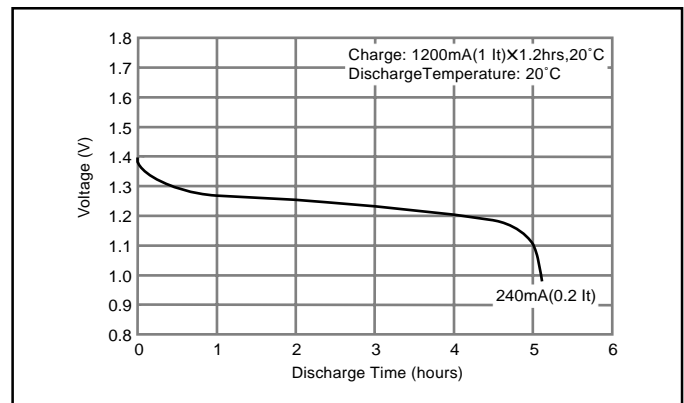

NICKEL METAL HYDRIDE BATTERIES: INDIVIDUAL DATA SHEET

HHR150AA Cylindrical AA size (HR 15/51)

Dimensions (with Tube) (mm)

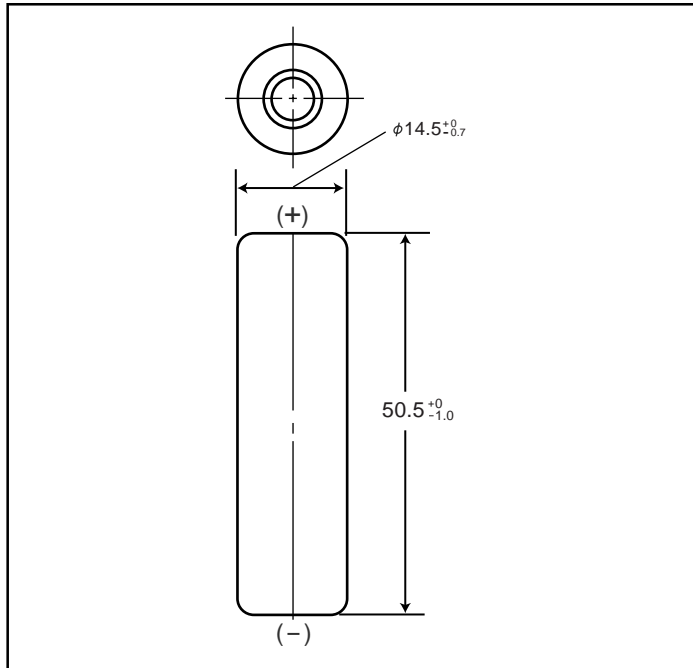

Specifications

	mm	inch
Diameter	14.5+0/-0.7	0.57+0/-0.03
Height	50.0+0/-1.0	1.97+0/-0.06
Approximate Weight	Grams	Ounces
	26	0.92

Nominal Voltage		1.2V		
Discharge Capacity*	Average**	1580 mAh		
	Rated (Min.)	1500 mAh		
Approx. Internal impedance at 1000Hz at charged state.		20mΩ		
Charge	Standard	150mA (0.1It) x 16hrs.		
	Rapid	1500mA (1It) x 1.2 hrs.		
Ambient Temperature	Charge	Standard	°C	°F
			0°C to 45°C	32°F to 113°F
	Rapid	0°C to 40°C	32°F to 104°F	
		Discharge -10°C to 65°C 14°F to 149°F		
	Storage	< 1 year	-20°C to 35°C	-4°F to 95°F
< 3 months		-20°C to 45°C	-4°F to 113°F	
< 1 month		-20°C to 55°C	-4°F to 131°F	

* After charging at 0.1It for 16 hours, discharging at 0.2It.

** For reference only.

Battery performance and cycle life are strongly affected by how they are used. In order to maximize battery safety, please consult Panasonic when determining charge / discharge specs, warning label contents and unit design.

Note: [It] was previously expressed as [C]. [It] is an IEC standard expression for the amount of charge or discharge current and is expressed as:

$$It(A) = Cn (Ah)/1h.$$

- [It] is the reference test current in amperes
- [Cn] is the rated capacity of the cell or battery in Ampere-hours.
- n = the time base [hours] for which the rated capacity is declared

Typical Charge Characteristics

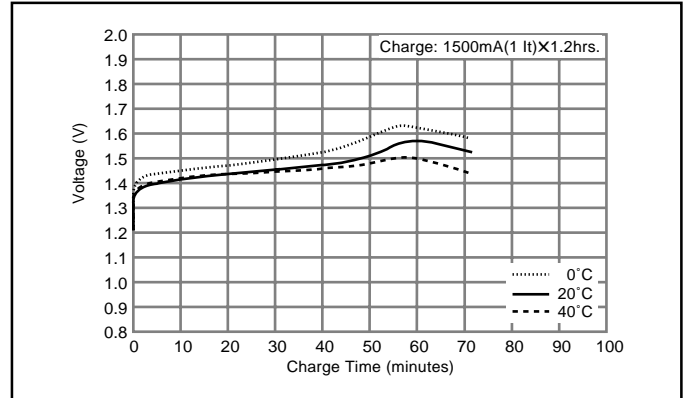

Typical Discharge Characteristics

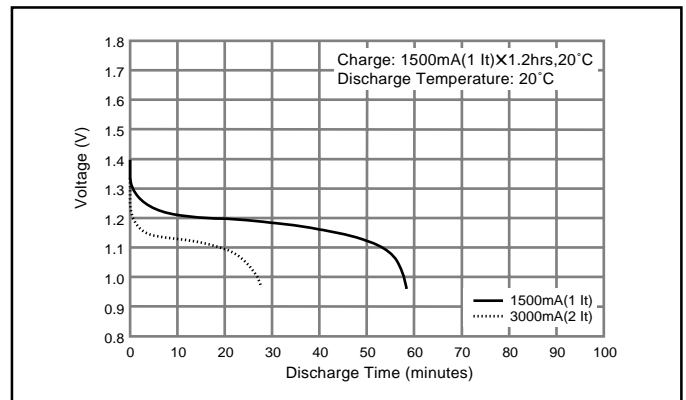
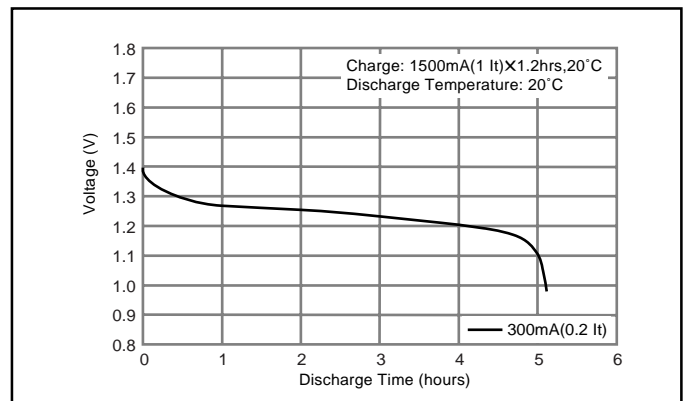

NICKEL METAL HYDRIDE BATTERIES: INDIVIDUAL DATA SHEET

HHR210AA/B Cylindrical AA size (HR 15/51)

Dimensions (with Tube) (mm)

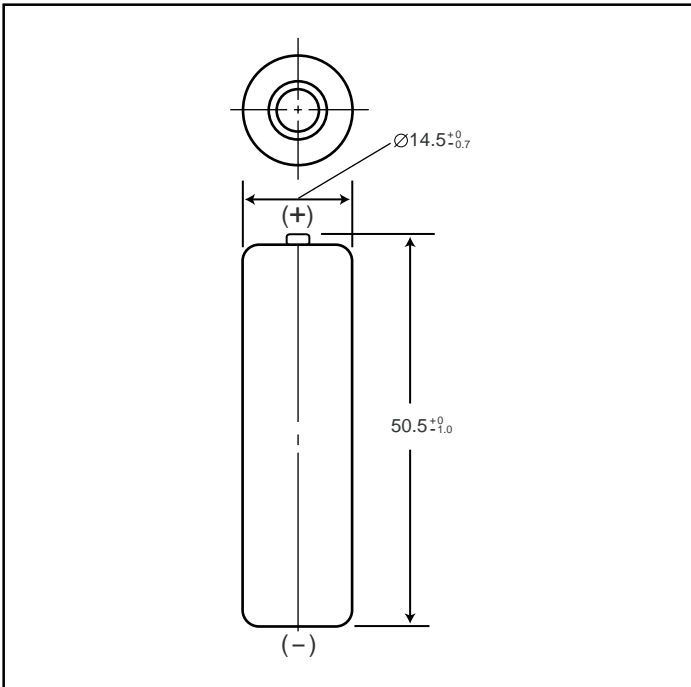

Specifications

	mm	inch
Diameter	14.5 +0/-0.7	0.57 +0/-0.3
Height	50.5 +0/-1.0	1.99 +0/-0.5
Approximate Weight	Grams	Ounces
	29	1.02

Nominal Voltage		1.2V		
Discharge Capacity*	Average**	2080mAh		
	Rated (Min.)	2000mAh		
Approx. internal Impedance at 1000Hz at charged state.		25mΩ		
Charge	Standard	200mA (0.1It) x 16 hrs.		
	Rapid	1200mA (1It) x 2 hrs.		
Ambient Temperature	Charge	Standard	°C	°F
			0°C to 45°C	32°F to 113°F
	Rapid	0°C to 40°C	32°F to 113°F	
		Discharge		-10°C to 65°C
	Storage	< 1 year	-20°C to 35°C	-4°F to 95°F
		< 3 months	-20°C to 45°C	-4°F to 113°F
< 1 month		-20°C to 55°C	-4°F to 131°F	

* After charging at 0.1It for 16 hours, discharging at 0.2It.

** For reference only.

Battery performance and cycle life are strongly affected by how they are used. In order to maximize battery safety, please consult Panasonic when determining charge / discharge specs, warning label contents and unit design.

Note: [It] was previously expressed as [C]. [It] is an IEC standard expression for the amount of charge or discharge current and is expressed as:

$$It(A) = C_n (Ah)/1h$$

* [It] is the reference test current in amperes

* [C_n] is the rated capacity of the cell or battery in Ampere-hours.

n = the time base [hours] for which the rated capacity is declared

Typical Charge Characteristics

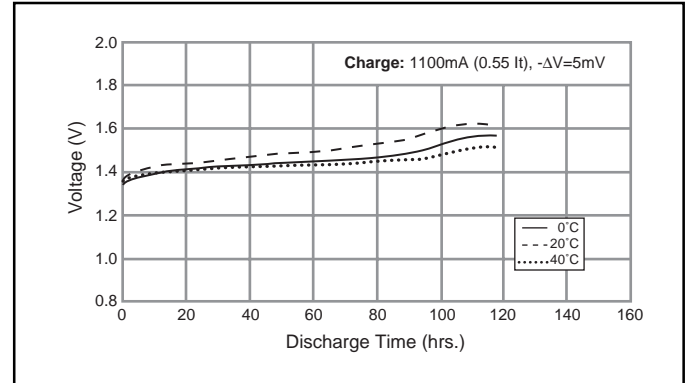

Typical Discharge Characteristics

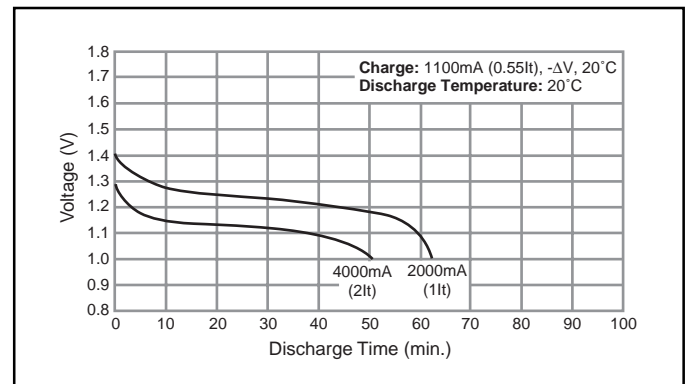
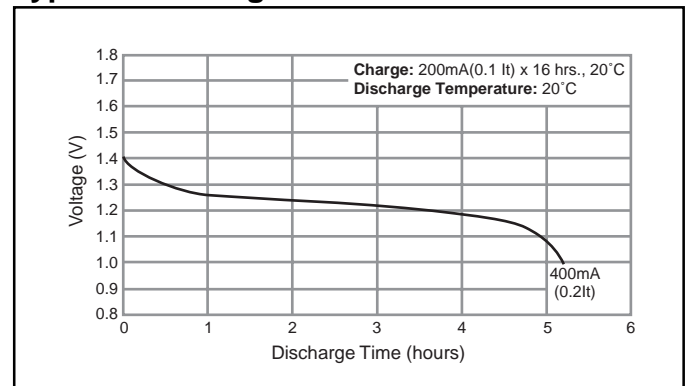

NICKEL METAL HYDRIDE BATTERIES: INDIVIDUAL DATA SHEET

HHR200A Cylindrical 4/5A size (HR 17/43)

Dimensions (with Tube) (mm)

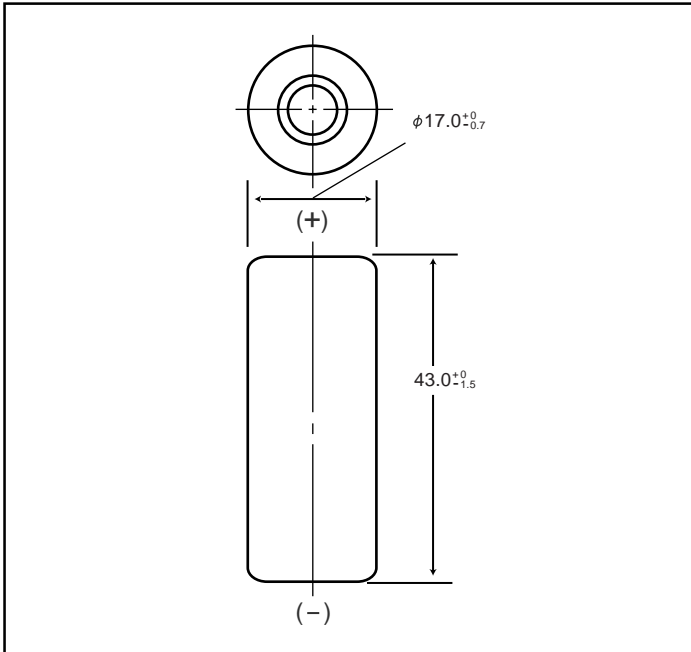

Typical Charge Characteristics

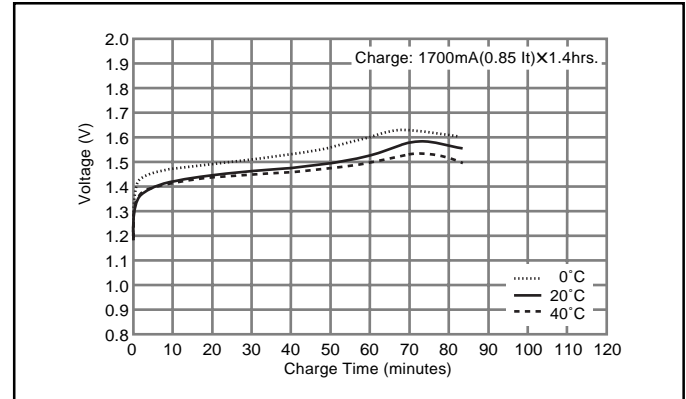

Typical Discharge Characteristics

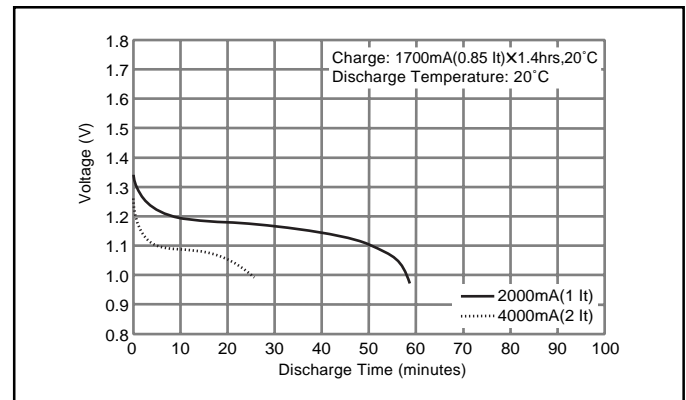
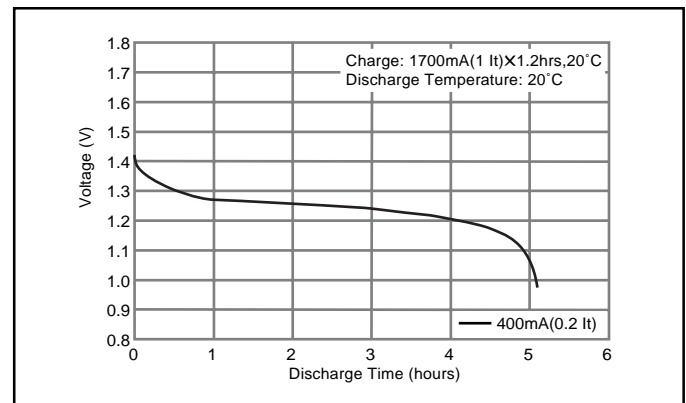

Specifications

	mm	inch
Diameter	17.0+0/-0.7	0.67+0/-0.03
Height	43.0+0/-1.5	1.69+0/-0.06
Approximate Weight	Grams	Ounces
	32	1.13

Nominal Voltage		1.2V		
Discharge Capacity*	Average**	2040 mAh		
	Rated (Min.)	2000 mAh		
Approx. Internal impedance at 1000Hz at charged state.		20mΩ		
Charge	Standard	200mA (0.1It) x 16hrs.		
	Rapid	2000mA (1It) x 1.2 hrs.		
Ambient Temperature	Charge	Standard	°C	°F
			0°C to 45°C	32°F to 113°F
	Rapid	0°C to 40°C	32°F to 104°F	
	Discharge	-10°C to 65°C		14°F to 149°F
		Storage	< 1 year	-20°C to 35°C
< 3 months			-20°C to 45°C	-4°F to 113°F
< 1 month	-20°C to 55°C		-4°F to 131°F	

* After charging at 0.1It for 16 hours, discharging at 0.2It.

** For reference only.

Battery performance and cycle life are strongly affected by how they are used. In order to maximize battery safety, please consult Panasonic when determining charge / discharge specs, warning label contents and unit design.

Note: [It] was previously expressed as [C]. [It] is an IEC standard expression for the amount of charge or discharge current and is expressed as:
 $It(A) = C_n (Ah)/1h.$

- [It] is the reference test current in amperes
- [Cn] is the rated capacity of the cell or battery in Ampere-hours.
- n = the time base [hours] for which the rated capacity is declared

NICKEL METAL HYDRIDE BATTERIES: INDIVIDUAL DATA SHEET

HHR210AH Cylindrical A size (HR 17/50)

Dimensions (with Tube) (mm)

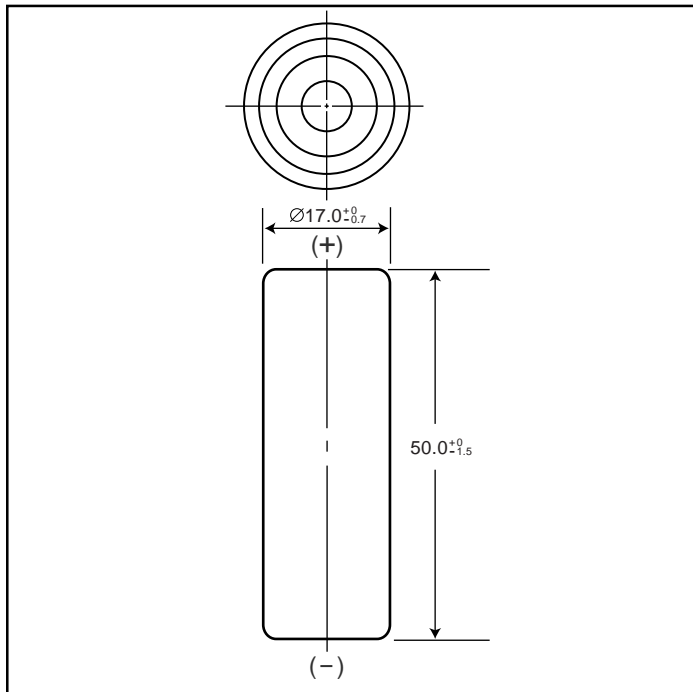

Specifications

	mm	inch
Diameter	17.0+0/-0.7	0.67+0/-0.03
Height	50.0+0/-1.5	1.97+0/-0.06
Approximate Weight	Grams	Ounces
	38	1.34

Nominal Voltage		1.2V	
Discharge Capacity ¹	Average ²	2050mAh	
	Rated (Min.)	1900mAh	
Approx. internal Impedance at 1000Hz at charged state.		20mΩ	
Charge	Standard	210mA (0.1It) x 16 hrs.	
	Rapid	-	
Ambient Temperature	Charge	Standard	°C
		Standard	°F
	Rapid	-10°C to 60°C	14°F to 140°F
	Discharge	-	-
Storage	< 1 year	-10°C to 60°C	14°F to 140°F
	< 3 months	-20°C to 35°C	-4°F to 95°F
	< 1 month	-20°C to 45°C	-4°F to 113°F
	< 1 week	-20°C to 55°C	-4°F to 131°F
		-20°C to 60°C	-4°F to 140°F

¹ After charging at 0.1It for 16 hours, discharging at 0.2It.

² For reference only.

Battery performance and cycle life are strongly affected by how they are used. In order to maximize battery safety, please consult Panasonic when determining charge / discharge specs, warning label contents and unit design.

Note: [It] was previously expressed as [C]. [It] is an IEC standard expression for the amount of charge or discharge current and is expressed as:

$$It(A) = C_n (Ah)/1h.$$

- [It] is the reference test current in amperes
- [C_n] is the rated capacity of the cell or battery in Ampere-hours.
- n = the time base [hours] for which the rated capacity is declared

Typical Charge Characteristics

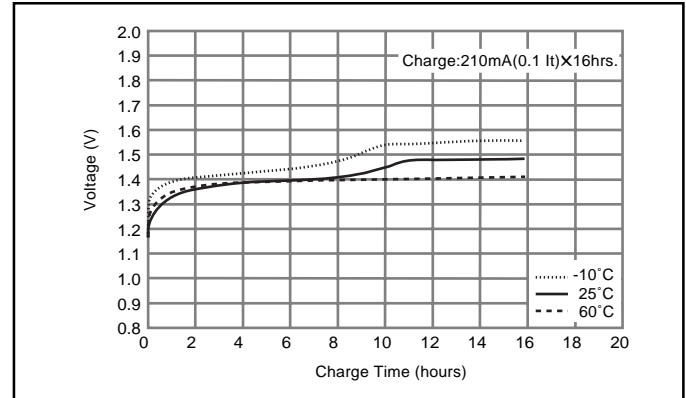

Typical Discharge Characteristics

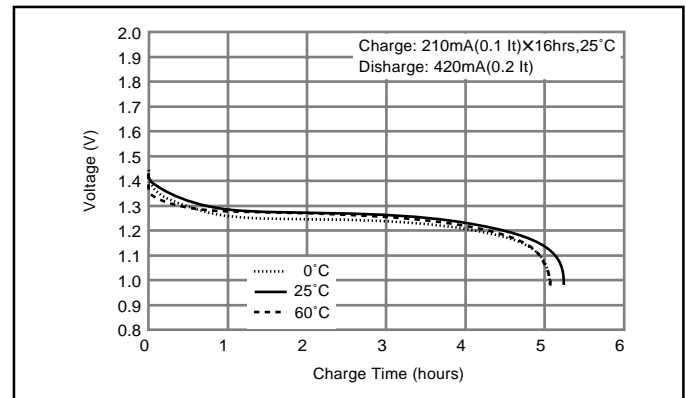
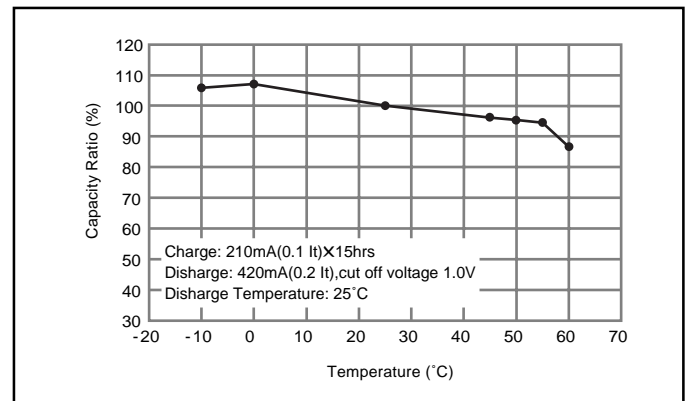

NICKEL METAL HYDRIDE BATTERIES: INDIVIDUAL DATA SHEET

HHR210A Cylindrical A size (HR 17/50)

Dimensions (with Tube) (mm)

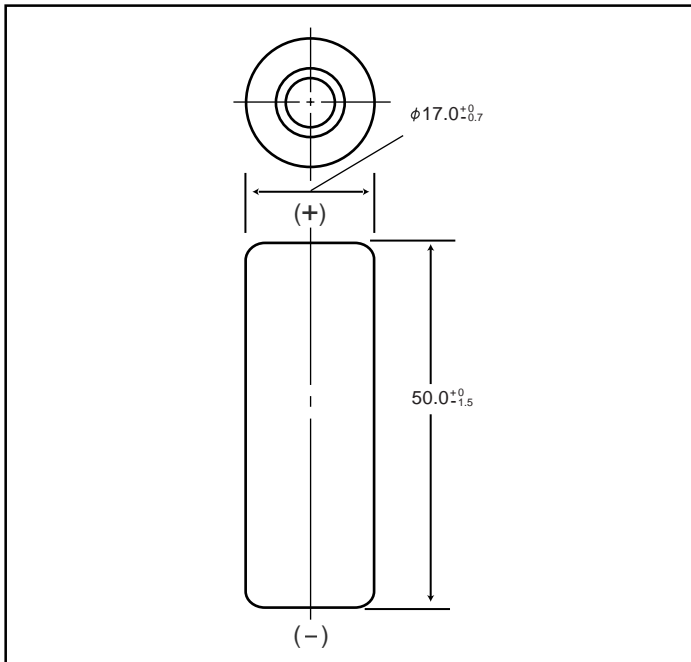

Specifications

	mm	inch
Diameter	17.0+0/-0.7	0.67+0/-0.03
Height	50.0+0/-1.5	1.97+0/-0.06
Approximate Weight	Grams	Ounces
	38	1.34

Nominal Voltage		1.2V		
Discharge Capacity*	Average**	2200 mAh		
	Rated (Min.)	2100 mAh		
Approx. Internal impedance at 1000Hz at charged state.		20mΩ		
Charge	Standard	210mA (0.1It) x 16hrs.		
	Rapid	2100mA (1It) x 1.2 hrs.		
Ambient Temperature	Charge	Standard	°C	°F
			0°C to 45°C	32°F to 113°F
	Rapid	0°C to 40°C	32°F to 104°F	
		Discharge		-10°C to 65°C
Storage	< 1 year	-20°C to 35°C	-4°F to 95°F	
	< 3 months	-20°C to 45°C	-4°F to 113°F	
	< 1 month	-20°C to 55°C	-4°F to 131°F	

* After charging at 0.1It for 16 hours, discharging at 0.2It.

** For reference only.

Battery performance and cycle life are strongly affected by how they are used. In order to maximize battery safety, please consult Panasonic when determining charge / discharge specs, warning label contents and unit design.

Note: [It] was previously expressed as [C]. [It] is an IEC standard expression for the amount of charge or discharge current and is expressed as:
It(A) = Cn (Ah)/1h.

- [It] is the reference test current in amperes
- [Cn] is the rated capacity of the cell or battery in Ampere-hours.
n = the time base [hours] for which the rated capacity is declared

Typical Charge Characteristics

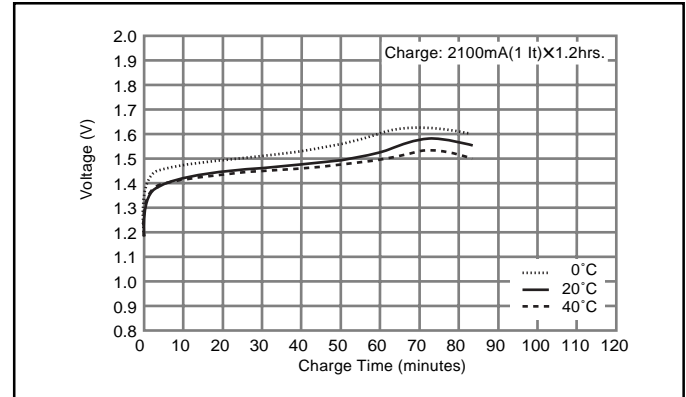

Typical Discharge Characteristics

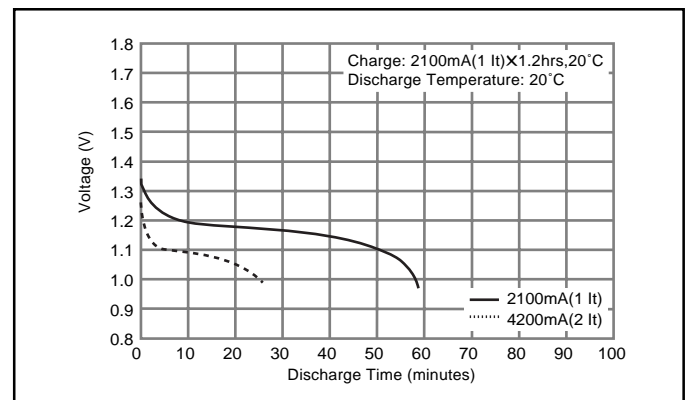
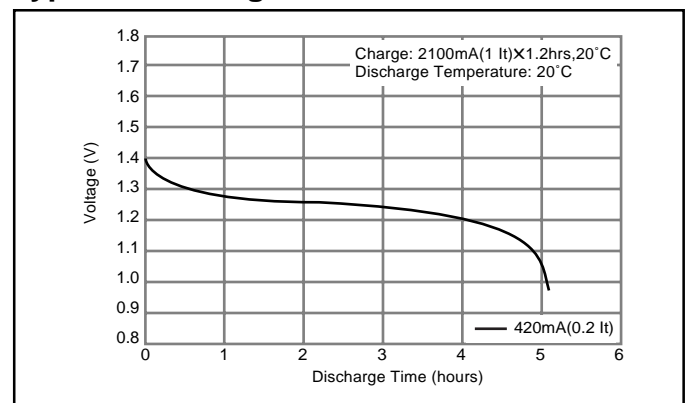

NICKEL METAL HYDRIDE BATTERIES: INDIVIDUAL DATA SHEET

HHR380A Cylindrical L-A size (HR 17/67)

Dimensions (with Tube) (mm)

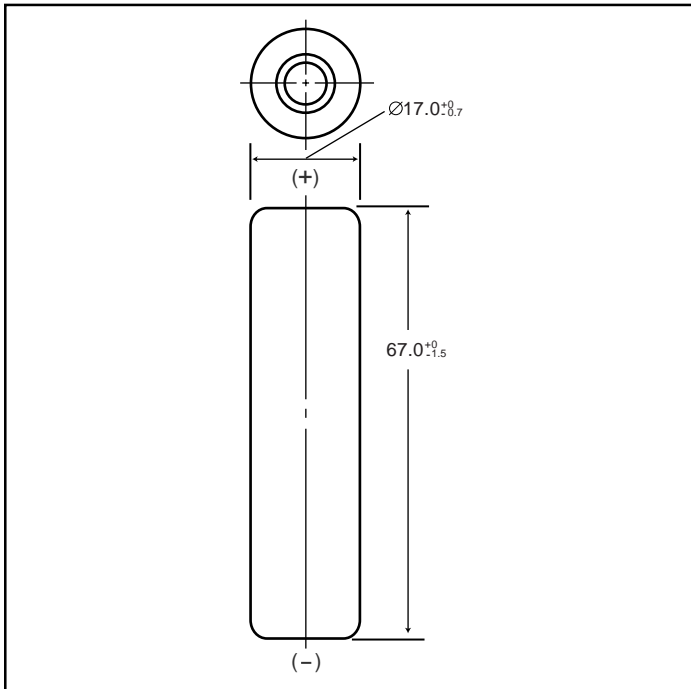

Typical Charge Characteristics

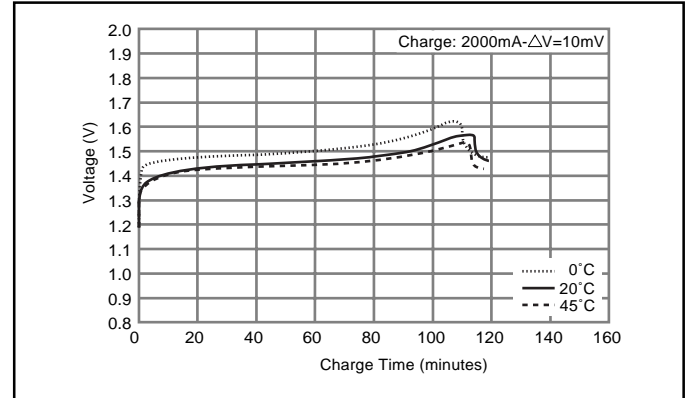

Typical Discharge Characteristics

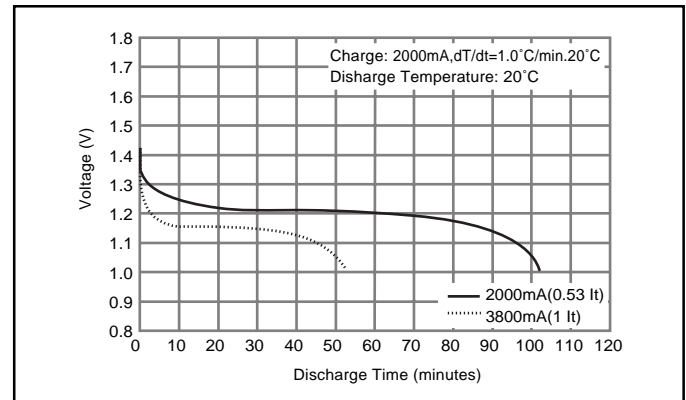
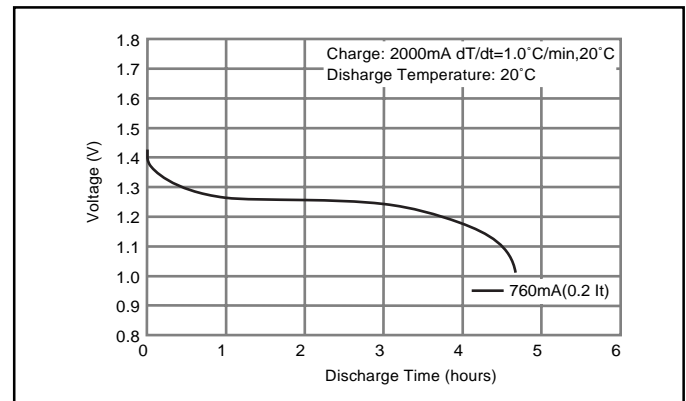

Specifications

	mm	inch
Diameter	17.0+0/-0.7	0.67+0/-0.03
Height	67.0+0/-1.5	2.64+0/-0.06
Approximate Weight	Grams	Ounces
	53	1.87

Nominal Voltage		1.2V		
Discharge Capacity*	Average**	3800 mAh		
	Rated (Min.)	3700 mAh		
Approx. Internal impedance at 1000Hz at charged state.		25mΩ		
Charge	Standard	370mA (0.1It) x 16hrs.		
	Rapid***	2000mA dT/dt		
Ambient Temperature	Charge	Standard	°C	°F
			0°C to 45°C	32°F to 113°F
	Rapid	0°C to 40°C	32°F to 104°F	
		Discharge	-10°C to 65°C	14°F to 149°F
Storage	< 1 year	-20°C to 35°C	-4°F to 95°F	
	< 3 months	-20°C to 45°C	-4°F to 113°F	
	< 1 month	-20°C to 55°C	-4°F to 131°F	

* After charging at 0.1It for 16 hours, discharging at 0.2It.

** For reference only.

*** For rapid charge: use dT/dt charge termination method. Refer to the Nickel Metal Hydride "Charge Methods" section for further details. Battery performance and cycle life are strongly affected by how they are used. In order to maximize battery safety, please consult Panasonic when determining charge / discharge specs, warning label contents and unit design.

Note: [It] was previously expressed as [C]. [It] is an IEC standard expression for the amount of charge or discharge current and is expressed as:
 $It(A) = C_n (Ah)/1h.$

- [It] is the reference test current in amperes
- [C_n] is the rated capacity of the cell or battery in Ampere-hours.
 n = the time base [hours] for which the rated capacity is declared

NICKEL METAL HYDRIDE BATTERIES: INDIVIDUAL DATA SHEET

HHR330APH Cylindrical L-Fat A size (HR 18/67)

Dimensions (with Tube) (mm)

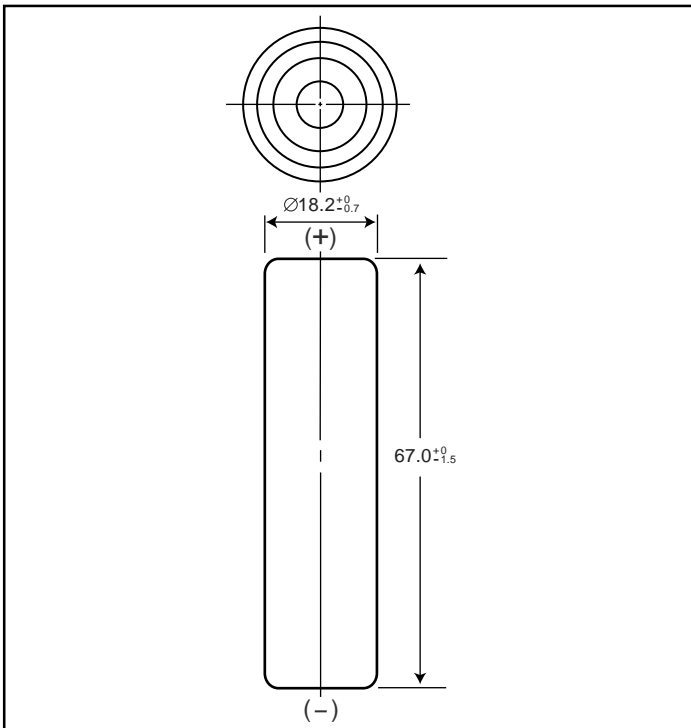

Specifications

	mm	inch
Diameter	18.2+0/-0.7	0.72+0/-0.03
Height	67.0+0/-1.5	2.64+0/-0.06
Approximate Weight	Grams	Ounces
	60	2.12

Nominal Voltage		1.2V	
Discharge Capacity ¹	Average ²	3300 mAh	
	Rated (Min.)	3200 mAh	
Approx. Internal impedance at 1000Hz at charged state.		5.5mΩ	
Charge	Standard	330mA x 16hrs.	
	Rapid ³	1650mA x 2.4 hrs. ⁴	
	Low Rate	165mA x 32 hrs. 110mA x 48 hrs.	
Ambient Temperature	Charge	Standard	°C °F
		Rapid	-10°C to 45°C 14°F to 113°F
Storage	Discharge	-10°C to 60°C 14°F to 140°F	
		< 1 year	-20°C to 35°C -4°F to 95°F
	< 6 months	-20°C to 45°C -4°F to 113°F	
	< 1 month	-20°C to 55°C -4°F to 131°F	
	< 1 week	-20°C to 65°C -4°F to 149°F	

¹ After charging at 0.1It for 16 hours, discharging at 0.2It.

² For reference only.

³ Need specially designed control system

Control System:

dT/dt cut-off; 1 to 2°C/min

-ΔV cut-off; -ΔV per cell = 5 to 10 mV

T-control; T=65°C

Rapid charger timer; 2.4h (at 1.25a)

Trickle timer; within 2h

⁴ With control system

Battery performance and cycle life are strongly affected by how they are used. In order to maximize battery safety, please consult Panasonic when determining charge / discharge specs, warning label contents and unit design.

Typical Charge Characteristics

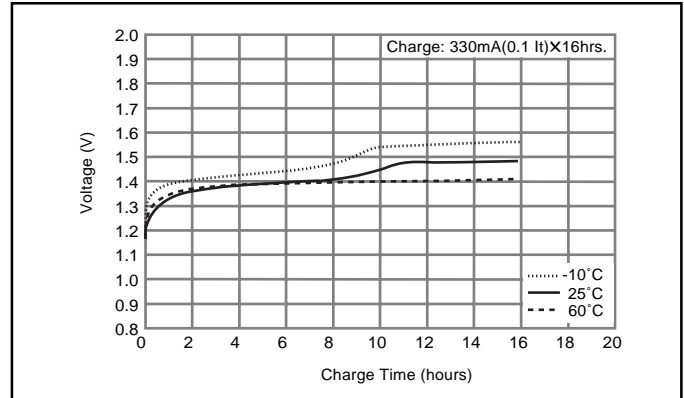

Typical Discharge Characteristics

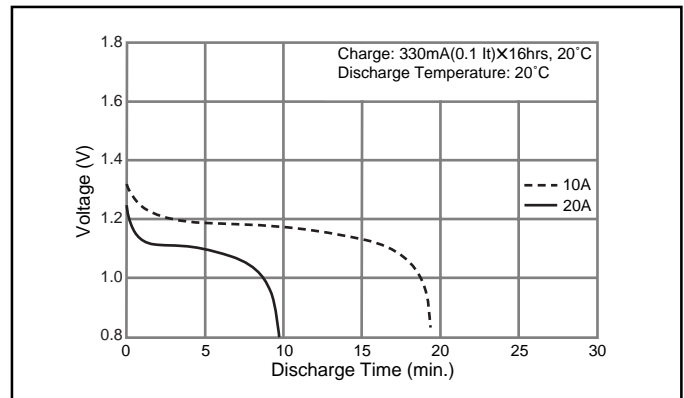
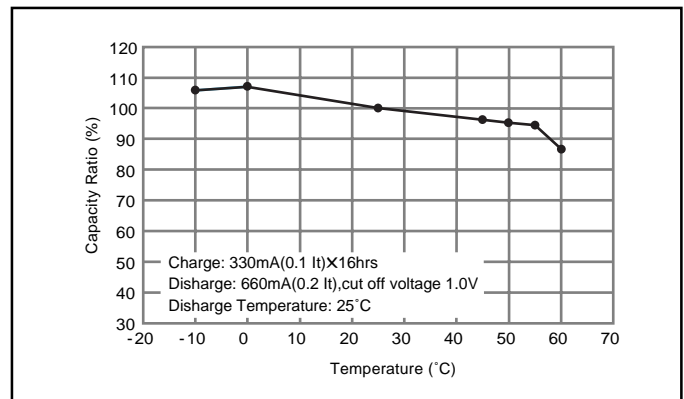

Note: [It] was previously expressed as [C]. [It] is an IEC standard expression for the amount of charge or discharge current and is expressed as:

$$It(A) = Cn(Ah)/1h.$$

- [It] is the reference test current in amperes
- [Cn] is the rated capacity of the cell or battery in Ampere-hours.
n = the time base [hours] for which the rated capacity is declared

NICKEL METAL HYDRIDE BATTERIES: INDIVIDUAL DATA SHEET

HHR370AH Cylindrical L-Fat A size (HR 18/67)

Dimensions (with Tube) (mm)

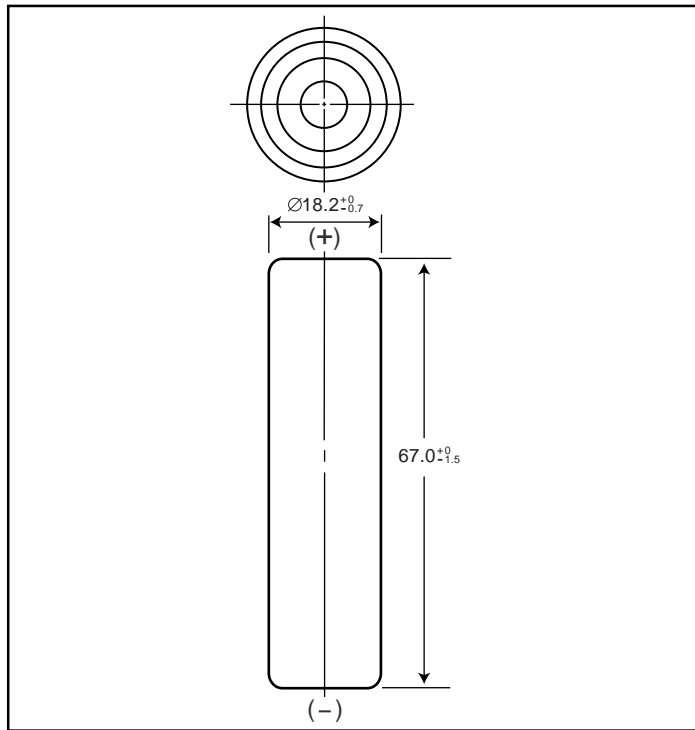

Specifications

	mm	inch
Diameter	18.2+0/-0.7	0.72+0/-0.03
Height	67.0+0/-1.5	2.64+0/-0.06
Approximate Weight	Grams	Ounces
	60	2.12

Nominal Voltage		1.2V	
Discharge Capacity ¹	Average ²	3700 mAh	
	Rated (Min.)	3500 mAh	
Approx. Internal impedance at 1000Hz at charged state.		20mΩ	
Charge	Standard	370mA x 16hrs.	
	Rapid ³	1750mA x 2.4 hrs. ⁴	
	Low Rate	185mA x 32 hrs. 123mA x 48 hrs.	
Ambient Temperature	Charge	Standard	°C: -10°C to 60°C °F: 14°F to 140°F
		Rapid	-10°C to 45°C -4°F to 113°F
	Discharge	Standard	-10°C to 60°C 14°F to 140°F
		< 1 year	-20°C to 35°C -4°F to 95°F
< 6 months		-20°C to 45°C -4°F to 113°F	
Storage	< 1 month	-20°C to 55°C -4°F to 131°F	
	< 1 week	-20°C to 65°C -4°F to 149°F	

¹ After charging at 0.1It for 16 hours, discharging at 0.2It.

² For reference only.

³ Need specially designed control system

Control System:

dT/dt cut-off; 1 to 2°C/min

-ΔV cut-off; -ΔV per cell = 5 to 10 mV

T-control; T=65°C

Rapid charger timer; 2.4h (at 1.25a)

Trickle timer; within 2h

⁴ With control system

Battery performance and cycle life are strongly affected by how they are used. In order to maximize battery safety, please consult Panasonic when determining charge / discharge specs, warning label contents and unit design.

Typical Charge Characteristics

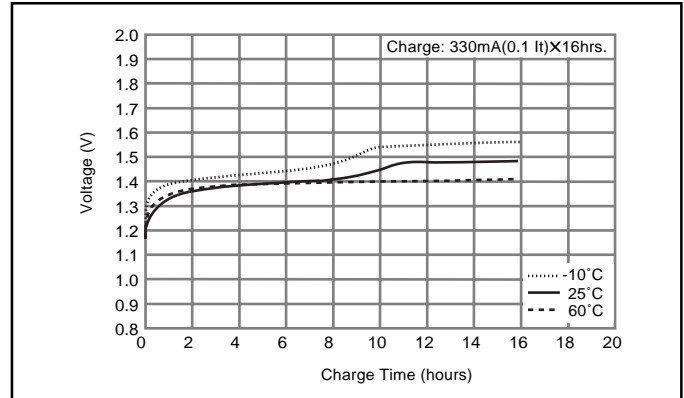

Typical Discharge Characteristics

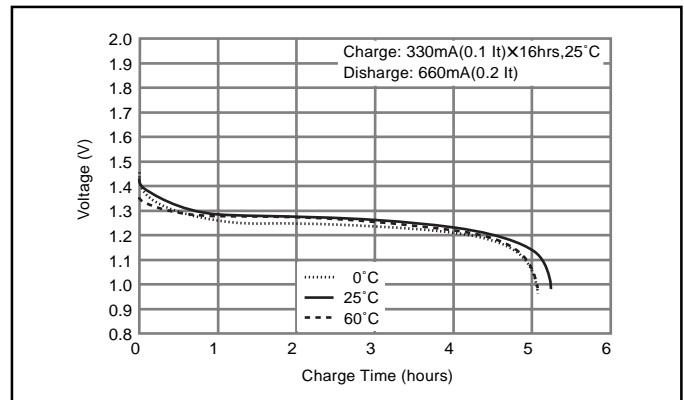
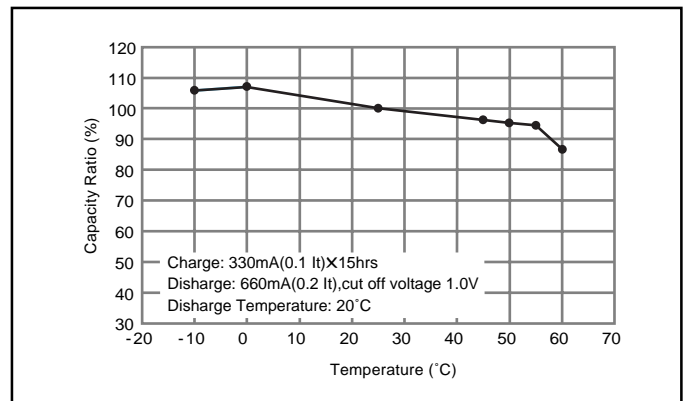

Note: [It] was previously expressed as [C]. [It] is an IEC standard expression for the amount of charge or discharge current and is expressed as: It(A) = Cn (Ah)/1h.

- [It] is the reference test current in amperes
- [Cn] is the rated capacity of the cell or battery in Ampere-hours.
n = the time base [hours] for which the rated capacity is declared

NICKEL METAL HYDRIDE BATTERIES: INDIVIDUAL DATA SHEET

HHR450A Cylindrical L-fat A size (HR 18/67)

Dimensions (with Tube) (mm)

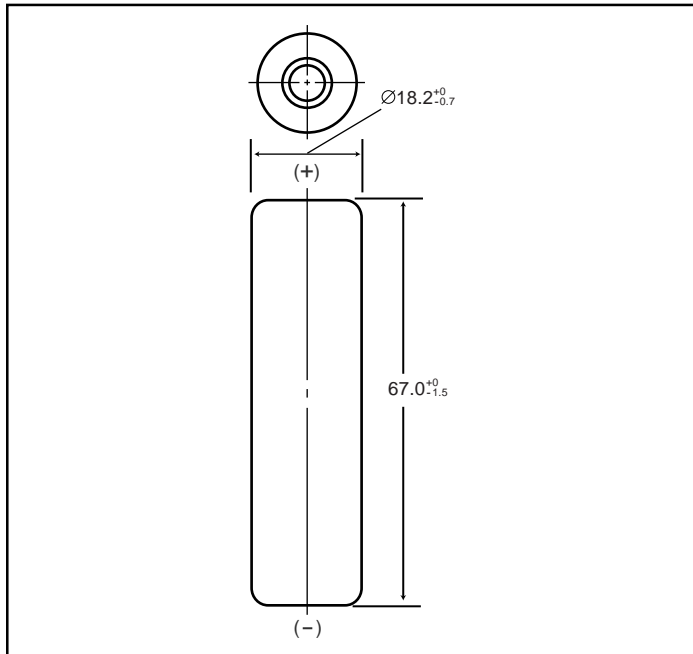

Specifications

	mm	inch
Diameter	18.2+0/-0.7	0.72+0/-0.03
Height	67.0+0/-1.5	2.64+0/-0.06
Approximate Weight	Grams	Ounces
	60	2.12

Nominal Voltage		1.2V		
Discharge Capacity*	Average**	4500 mAh		
	Rated (Min.)	4200 mAh		
Approx. Internal impedance at 1000Hz at charged state.		25mΩ		
Charge	Standard	420mA (0.1It) x 16hrs.		
	Rapid***	2000mA dT/dt		
Ambient Temperature	Charge	Standard	°C	°F
			0°C to 45°C	32°F to 113°F
	Rapid	0°C to 40°C	32°F to 104°F	
	Discharge	-10°C to 65°C		14°F to 149°F
		Storage	< 1 year	-20°C to 35°C
< 3 months			-20°C to 45°C	-4°F to 113°F
< 1 month	-20°C to 55°C		-4°F to 131°F	

* After charging at 0.1It for 16 hours, discharging at 0.2It.

** For reference only.

*** For rapid charge: use dT/dt charge termination method. Refer to the Nickel Metal Hydride "Charge Methods" section for further details.

Battery performance and cycle life are strongly affected by how they are used. In order to maximize battery safety, please consult Panasonic when determining charge / discharge specs, warning label contents and unit design.

Note: [It] was previously expressed as [C]. [It] is an IEC standard expression for the amount of charge or discharge current and is expressed as:
It(A) = Cn (Ah)/1h.

- [It] is the reference test current in amperes
- [Cn] is the rated capacity of the cell or battery in Ampere-hours.
n = the time base [hours] for which the rated capacity is declared

Typical Charge Characteristics

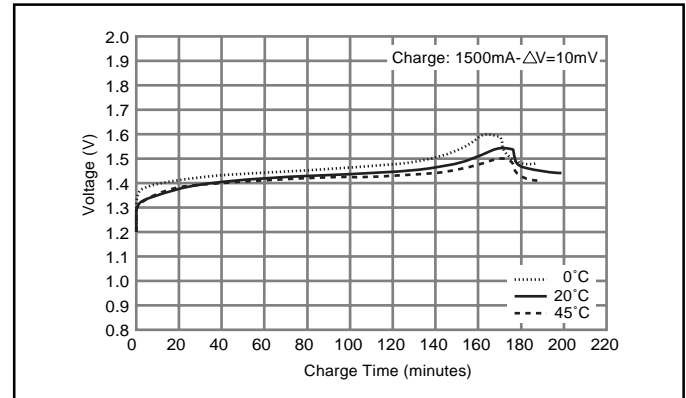

Typical Discharge Characteristics

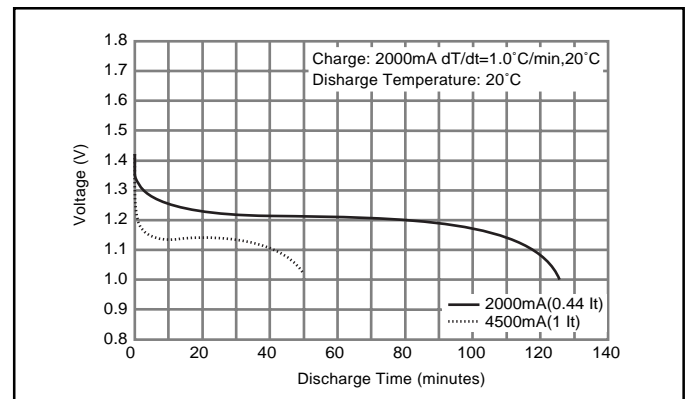
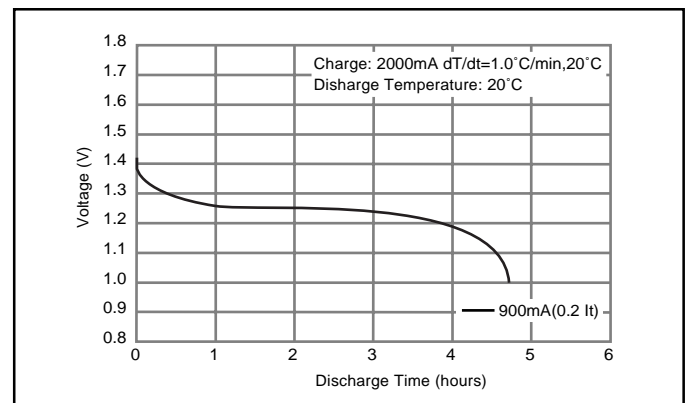

NICKEL METAL HYDRIDE BATTERIES: INDIVIDUAL DATA SHEET

HHR200SCP Cylindrical 4/5SC size (HR 23/34)

Dimensions (with Tube) (mm)

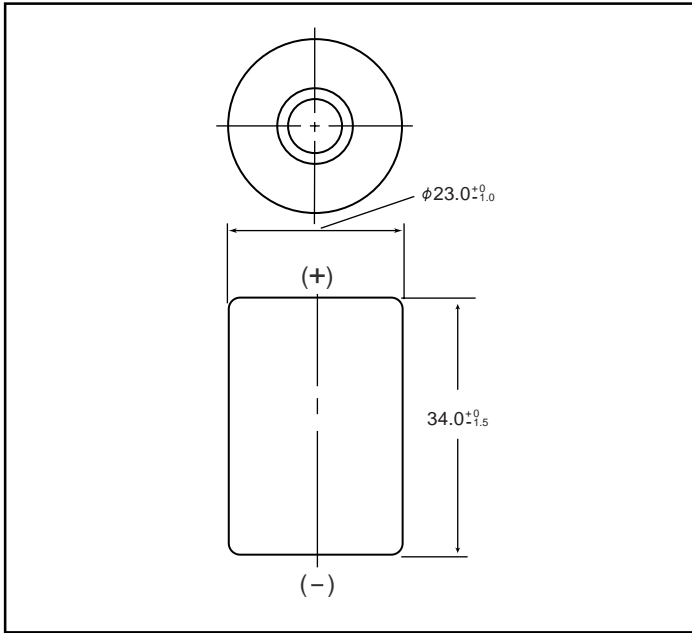

Specifications

	mm	inch
Diameter	23.0+0/-0.1	0.91+0/-0.04
Height	34.0+0/-1.5	1.34+0/-0.06
Approximate Weight	Grams	Ounces
	42	1.48

Nominal Voltage		1.2V		
Discharge Capacity*	Average**	2100 mAh		
	Rated (Min.)	1900 mAh		
Approx. Internal impedance at 1000Hz at charged state.		5mΩ		
Charge	Standard	200mA (0.1It) x 16hrs.		
	Rapid	2000mA (1It) x 1.2 hrs.		
Ambient Temperature	Charge	Standard	°C	°F
			0°C to 45°C	32°F to 113°F
	Rapid	0°C to 40°C	32°F to 104°F	
		Discharge	-10°C to 65°C	14°F to 149°F
Storage	< 2 years	-20°C to 35°C	-4°F to 95°F	
	< 6 months	-20°C to 45°C	-4°F to 113°F	

* After charging at 0.1It for 16 hours, discharging at 0.2It.

** For reference only.

Battery performance and cycle life are strongly affected by how they are used. In order to maximize battery safety, please consult Panasonic when determining charge / discharge specs, warning label contents and unit design.

Note: [It] was previously expressed as [C]. [It] is an IEC standard expression for the amount of charge or discharge current and is expressed as:
It(A) = Cn (Ah)/1h.

- [It] is the reference test current in amperes
- [Cn] is the rated capacity of the cell or battery in Ampere-hours.
n = the time base [hours] for which the rated capacity is declared

Typical Charge Characteristics

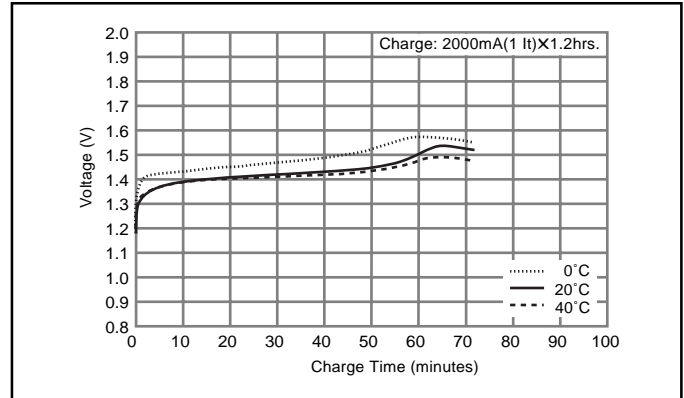

Typical Discharge Characteristics

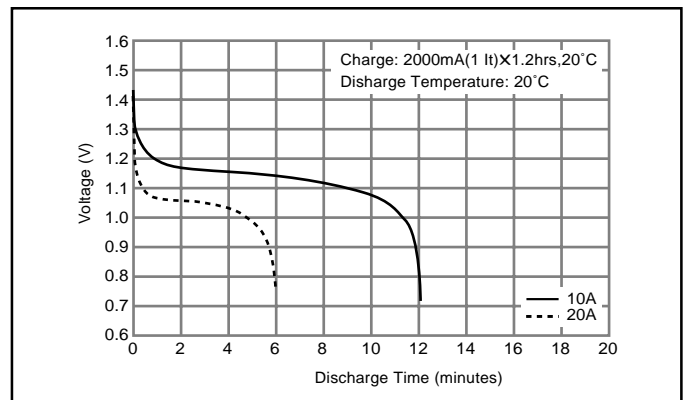
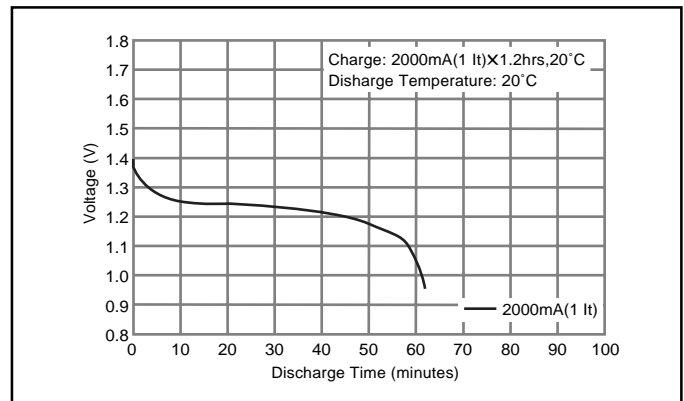

NICKEL METAL HYDRIDE BATTERIES: INDIVIDUAL DATA SHEET

HHR250SCH Cylindrical SC size (HR 23/43)

Dimensions (with Tube) (mm)

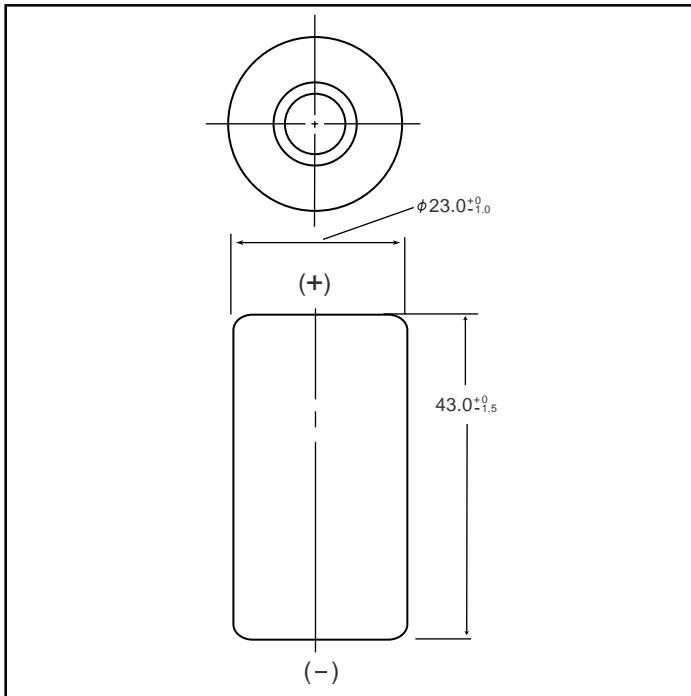

Specifications

	mm	inch
Diameter	23.0+0/-1.0	0.91+0/-0.04
Height	43.0+0/-1.5	1.69+0/-0.06
Approximate Weight	Grams	Ounces
	55	1.94

Nominal Voltage		1.2V	
Discharge Capacity ¹	Average ²	2650 mAh	
	Rated (Min.)	2500 mAh	
Approx. Internal impedance at 1000Hz at charged state.		5mΩ	
Charge	Standard	250mA x 16hrs.	
	Rapid ³	1250mA x 2.4 hrs. ⁴	
	Low Rate	125mA x 32 hrs. 83mA x 48 hrs.	
Ambient Temperature	Charge	Standard	°C °F
		Rapid	-10°C to 45°C 14°F to 113°F
Storage	Discharge	-10°C to 60°C 14°F to 140°F	
		< 1 year -20°C to 35°C -4°F to 95°F	
		< 6 months -20°C to 45°C -4°F to 113°F	
		< 1 month -20°C to 55°C -4°F to 131°F	
		< 1 week -20°C to 65°C -4°F to 149°F	

¹ After charging at 0.1It for 16 hours, discharging at 0.2It.

² For reference only.

³ Need specially designed control system

Control System:

dT/dt cut-off; 1 to 2°C/min

-ΔV cut-off; -ΔV per cell = 5 to 10 mV

T-control; T=65°C

Rapid charger timer; 2.4h (at 1.25a)

Trickle timer; within 2h

⁴ With control system

Battery performance and cycle life are strongly affected by how they are used. In order to maximize battery safety, please consult Panasonic when determining charge / discharge specs, warning label contents and unit design.

Typical Charge Characteristics

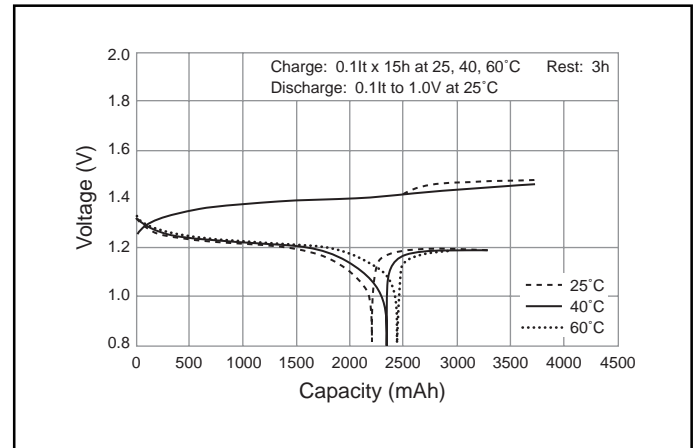

Typical Discharge Characteristics

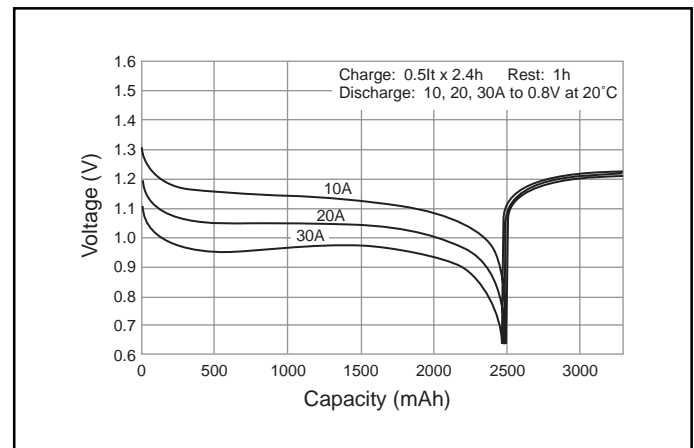
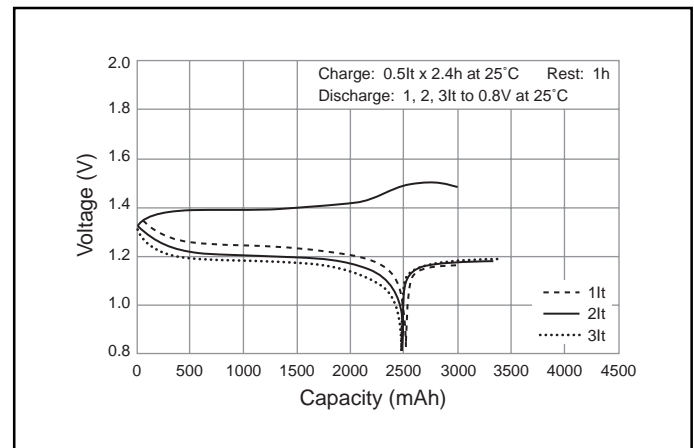

Note: [It] was previously expressed as [C]. [It] is an IEC standard expression for the amount of charge or discharge current and is expressed as:

$$It(A) = Cn(Ah)/1h$$

* [It] is the reference test current in amperes

* [Cn] is the rated capacity of the cell or battery in Ampere-hours.

n = the time base [hours] for which the rated capacity is declared

NICKEL METAL HYDRIDE BATTERIES: INDIVIDUAL DATA SHEET

HHR260SCP Cylindrical SC size (HR 23/43)

Dimensions (with Tube) (mm)

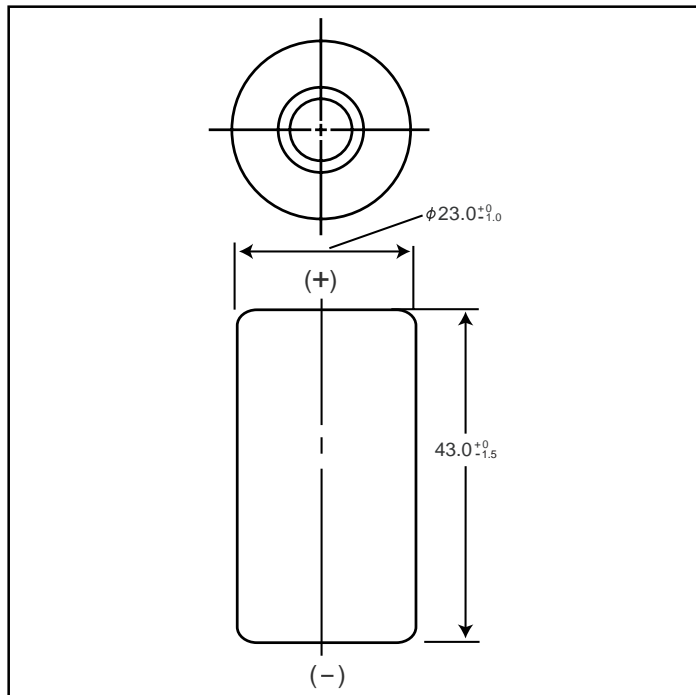

Specifications

	mm	inch
Diameter	23.0+0/-1.0	0.91+0/-0.04
Height	43.0+0/-1.5	1.69+0/-0.06
Approximate Weight	Grams	Ounces
	55	1.94

Nominal Voltage		1.2V		
Discharge Capacity ¹	Average ²	2600 mAh		
	Rated (Min.)	2450 mAh		
Approx. Internal impedance at 1000Hz at charged state.		5mΩ		
Charge	Standard	260mA x 16hrs.		
	Rapid	2600mA x 1.2 hrs.		
Ambient Temperature	Charge	Standard	°C	°F
			0°C to 45°C	32°F to 113°F
	Rapid	10°C to 40°C	50°F to 104°F	
		Discharge	-10°C to 65°C	14°F to 149°F
Storage	< 1 year	-20°C to 35°C	-4°F to 95°F	
	< 3 months	-20°C to 45°C	-4°F to 113°F	
	< 1 month	-20°C to 55°C	-4°F to 131°F	

¹ After charging at 0.1It for 16 hours, discharging at 0.2It.

² For reference only.

Battery performance and cycle life are strongly affected by how they are used. In order to maximize battery safety, please consult Panasonic when determining charge / discharge specs, warning label contents and unit design.

Note: [It] was previously expressed as [C]. [It] is an IEC standard expression for the amount of charge or discharge current and is expressed as:

$$It(A) = Cn (Ah)/1h$$

* [It] is the reference test current in amperes

* [Cn] is the rated capacity of the cell or battery in Ampere-hours.

n = the time base [hours] for which the rated capacity is declared

Typical Charge Characteristics

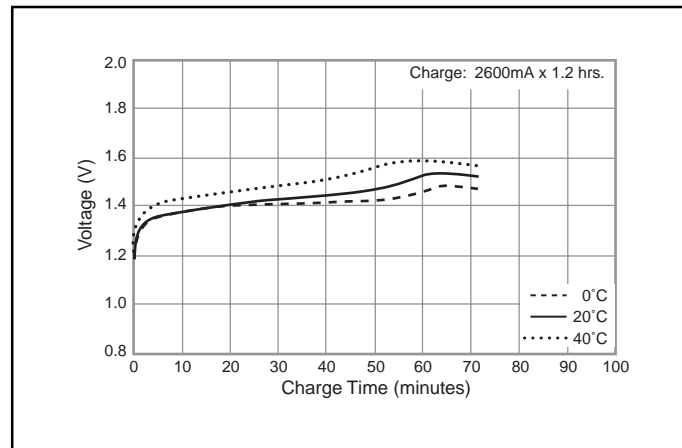

Typical Discharge Characteristics

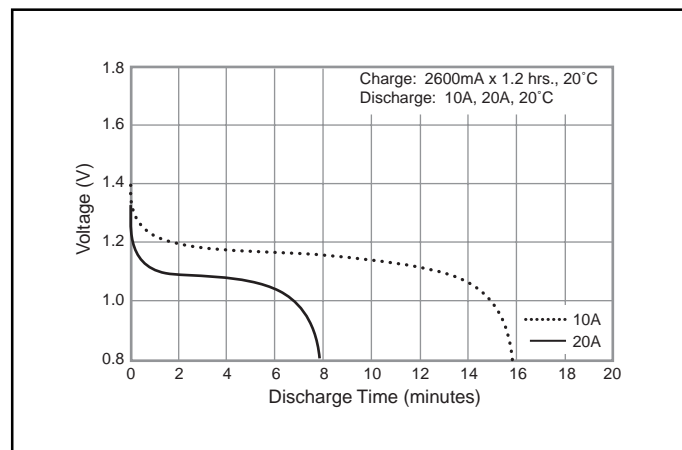
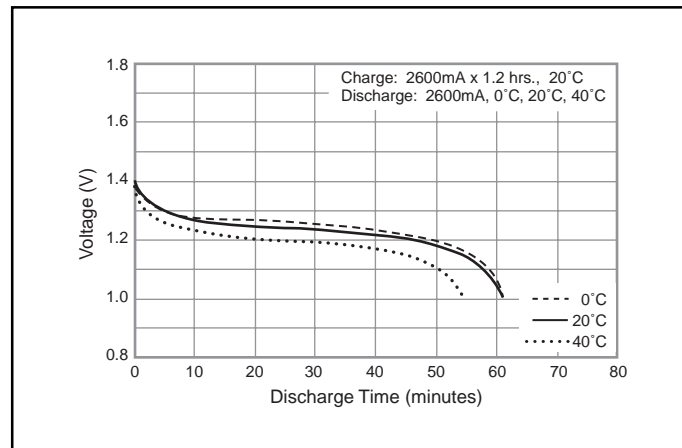

NICKEL METAL HYDRIDE BATTERIES: INDIVIDUAL DATA SHEET

HHR300SCP Cylindrical SC size (HR 23/43)

Dimensions (with Tube) (mm)

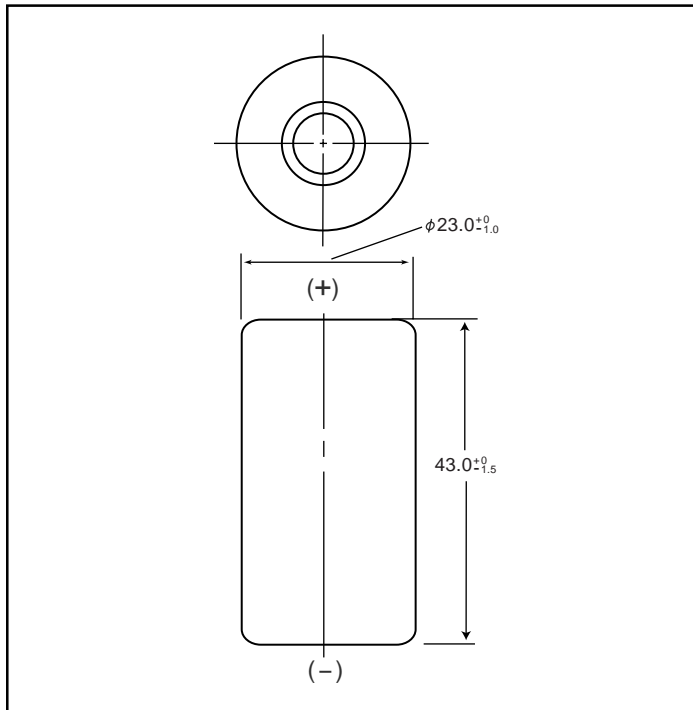

Typical Charge Characteristics

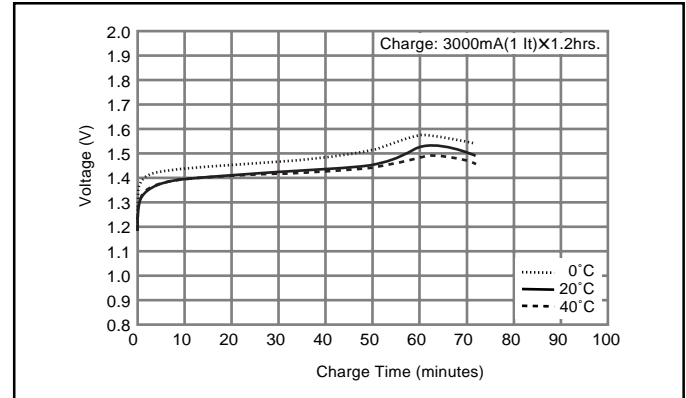

Typical Discharge Characteristics

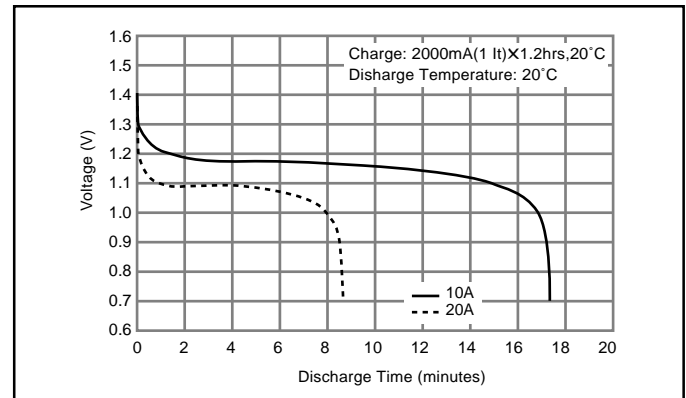
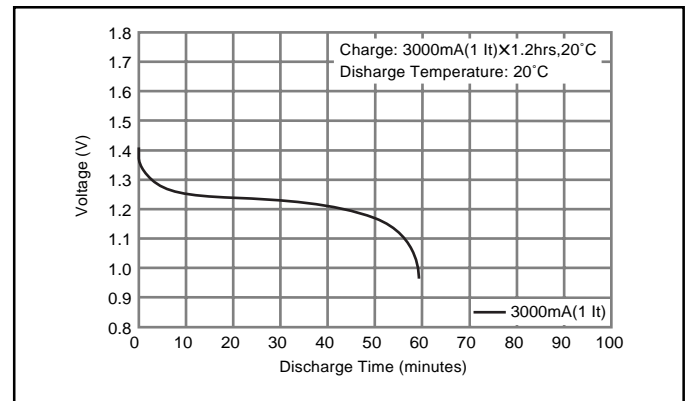

Specifications

	mm	inch
Diameter	23.0+0/-0.1	0.91+0/-0.04
Height	43.0+0/-1.5	1.69+0/-0.06
Approximate Weight	Grams	Ounces
	57	2.01

Nominal Voltage		1.2V		
Discharge Capacity*	Average**	3050 mAh		
	Rated (Min.)	2800 mAh		
Approx. Internal impedance at 1000Hz at charged state.		4mΩ		
Charge	Standard	300mA (0.1It) x 16hrs.		
	Rapid	3000mA (1It) x 1.2 hrs.		
Ambient Temperature	Charge	Standard	°C	°F
			0°C to 45°C	32°F to 113°F
	Rapid	0°C to 40°C	32°F to 104°F	
		Discharge	-10°C to 65°C	14°F to 149°F
Storage	< 2 years	-20°C to 35°C	-4°F to 95°F	
	< 6 months	-20°C to 45°C	-4°F to 113°F	

* After charging at 0.1It for 16 hours, discharging at 0.2It.

** For reference only.

Battery performance and cycle life are strongly affected by how they are used. In order to maximize battery safety, please consult Panasonic when determining charge / discharge specs, warning label contents and unit design.

Note: [It] was previously expressed as [C]. [It] is an IEC standard expression for the amount of charge or discharge current and is expressed as:
It(A) = Cn (Ah)/1h.

- [It] is the reference test current in amperes
- [Cn] is the rated capacity of the cell or battery in Ampere-hours.
n = the time base [hours] for which the rated capacity is declared

NICKEL METAL HYDRIDE BATTERIES: INDIVIDUAL DATA SHEET

HHR300CH Cylindrical C size (HR 26/50) for backup use

Dimensions (with Tube) (mm)

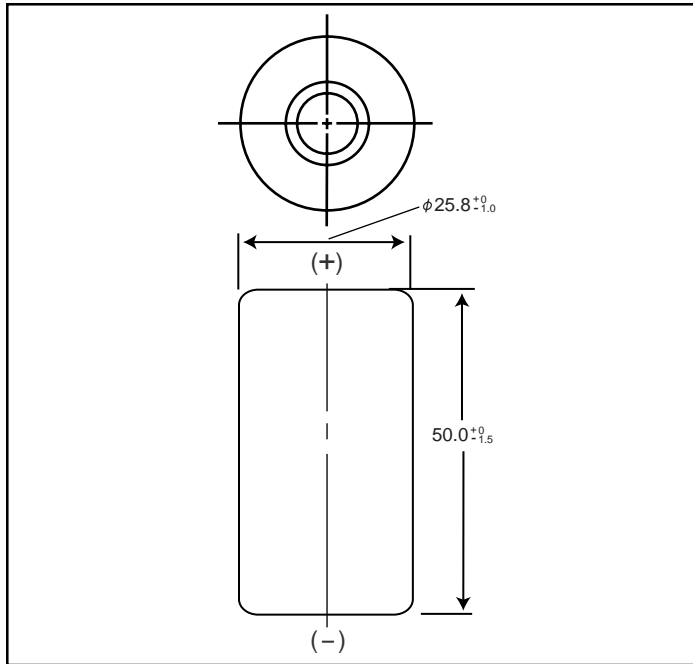

Specifications

	mm	inch
Diameter	25.8+0/-1.0	1.02+0/-0.04
Height	50.0+0/-1.5	1.97+0/-0.06
Approximate Weight	Grams	Ounces
	80	2.82

Nominal Voltage		1.2V		
Discharge Capacity¹	Average²	3300 mAh		
	Rated (Min.)	3100 mAh		
Approx. Internal impedance at 1000Hz at charged state.		5mΩ		
Charge	Standard	300mA (0.1It) x 16hrs.		
	Rapid³	1500mA (1It) x 2.4 hrs. ⁴		
	Low Rate	155mA x 32 hrs. 100mA x 48 hrs.		
Ambient Temperature	Charge	Standard	°C	°F
			0°C to 45°C	32°F to 113°F
		Rapid	10°C to 40°C	32°F to 104°F
	Low Rate	-10°C to 45°C	14°F to 149°F	
	Discharge	-10°C to 65°C 14°F to 113°F		
	Storage	< 1 year	-20°C to 35°C	-4°F to 95°F
< 3 months		-20°C to 35°C	-4°F to 95°F	
< 1 month		-20°C to 55°C	-4°F to 131°F	

¹ After charging at 0.1It for 16 hours, discharging at 0.2It.

² For reference only.

³ Need specially designed control system

Control System:

dT/dt cut-off; 1 to 2°C/min

-ΔV cut-off; -ΔV per cell = 5 to 10 mV

T-control; T=65°C

Rapid charger timer; 2.4h (at 1.25a)

Trickle timer; within 2h

⁴ With control system

Battery performance and cycle life are strongly affected by how they are used. In order to maximize battery safety, please consult Panasonic when determining charge / discharge specs, warning label contents and unit design.

Typical Charge Characteristics

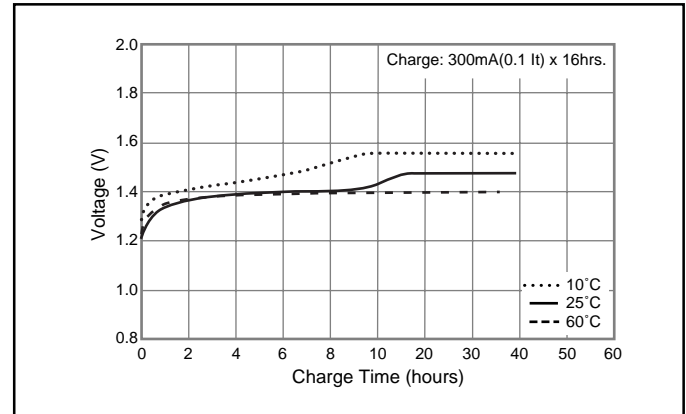

Typical Discharge Characteristics

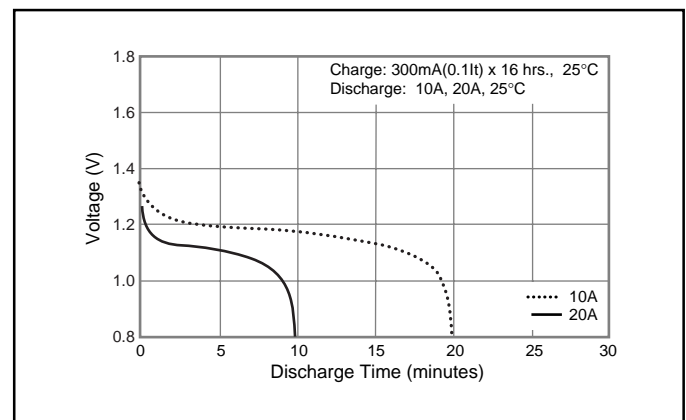
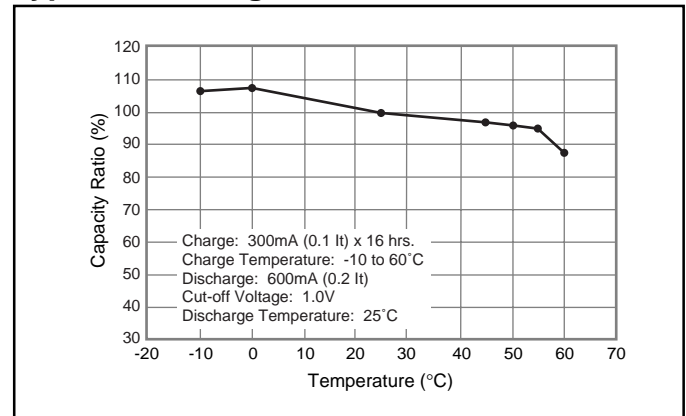

Note: [It] was previously expressed as [C]. [It] is an IEC standard expression for the amount of charge or discharge current and is expressed as: It(A) = Cn (Ah)/1h.

- [It] is the reference test current in amperes
- [Cn] is the rated capacity of the cell or battery in Ampere-hours.
n = the time base [hours] for which the rated capacity is declared

NICKEL METAL HYDRIDE BATTERIES: INDIVIDUAL DATA SHEET

HHR650D Cylindrical D size (HR 33/62)

Dimensions (with Tube) (mm)

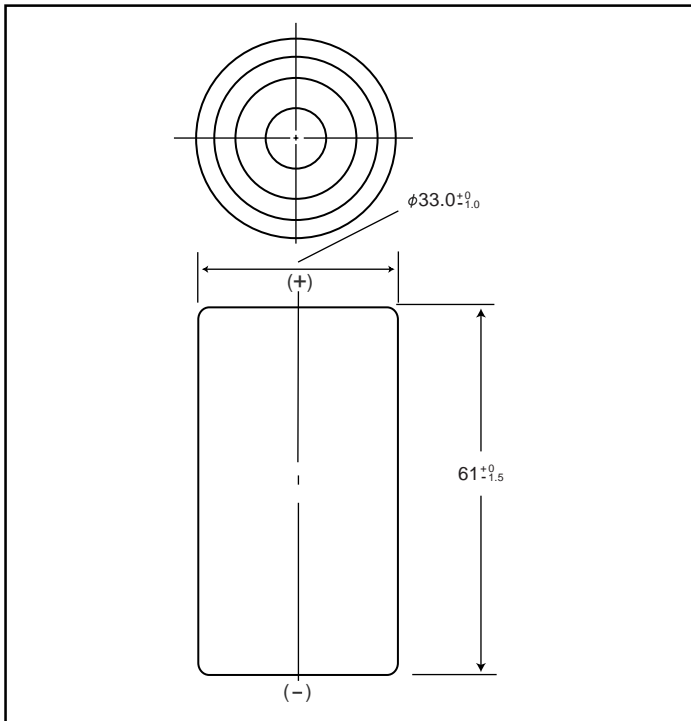

Specifications

	mm	inch
Diameter	33.0+0/-0.1	1.3+0/-0.04
Height	61+0/-1.5	2.40+0/-0.08
Approximate Weight	Grams	Ounces
	170	6.0

Nominal Voltage		1.2V		
Discharge Capacity*	Average**	6800 mAh		
	Rated (Min.)	6500 mAh		
Approx. Internal impedance at 1000Hz at charged state.		2mΩ		
Charge	Standard	650mA (0.1It) x 16hrs.		
	Rapid	6500mA (1It) x 1.2 hrs.		
Ambient Temperature	Charge	Standard	°C	°F
			0°C to 45°C	32°F to 113°F
	Rapid	0°C to 40°C	32°F to 104°F	
		Discharge		-10°C to 65°C
Storage	< 2 years	-20°C to 45°C	-4°F to 113°F	
	< 6 months	-20°C to 55°C	-4°F to 131°F	

* After charging at 0.1It for 16 hours, discharging at 0.2It.

** For reference only.

Battery performance and cycle life are strongly affected by how they are used. In order to maximize battery safety, please consult Panasonic when determining charge / discharge specs, warning label contents and unit design.

Note: [It] was previously expressed as [C]. [It] is an IEC standard expression for the amount of charge or discharge current and is expressed as:
It(A) = Cn (Ah)/1h.

- [It] is the reference test current in amperes
- [Cn] is the rated capacity of the cell or battery in Ampere-hours.
- n = the time base [hours] for which the rated capacity is declared

Typical Charge Characteristics

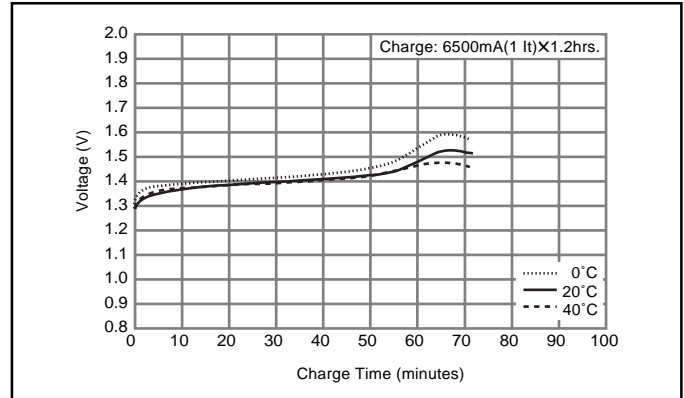

Typical Discharge Characteristics

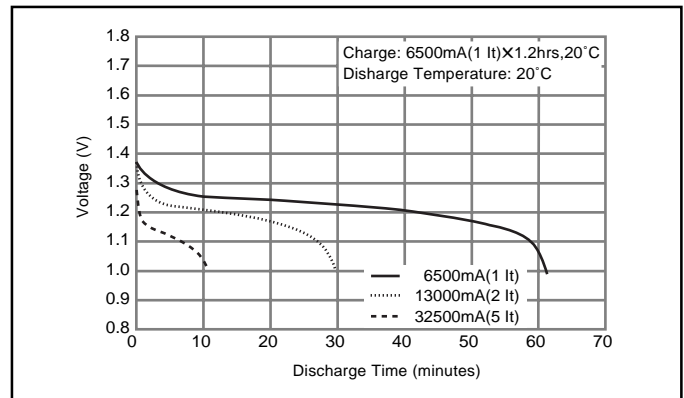
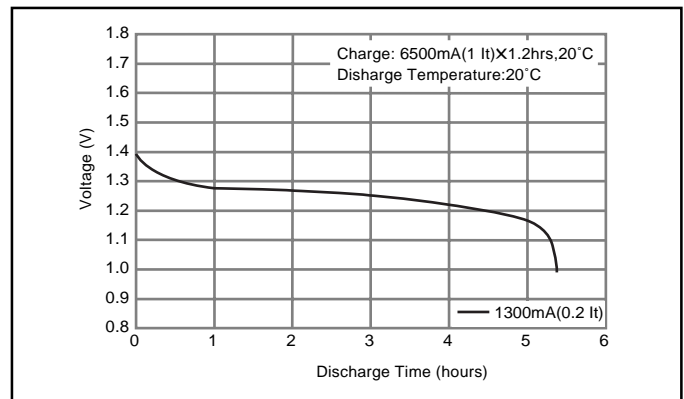

NICKEL METAL HYDRIDE BATTERIES: INDIVIDUAL DATA SHEET

HHR900D Cylindrical D size (HR 33/62)

Dimensions (with Tube) (mm)

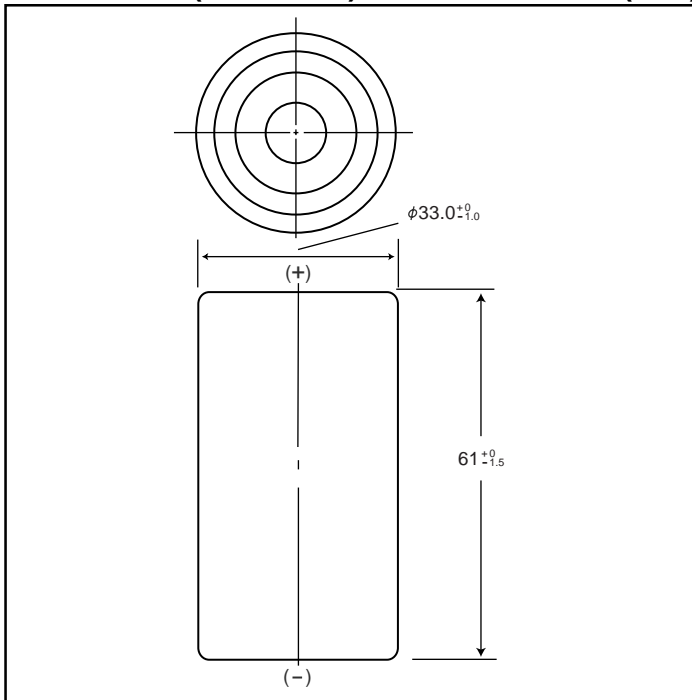

Specifications

	mm	inch
Diameter	33.0+0/-0.1	1.3+0/-0.04
Height	61.0+0/-1.5	2.40+0/-0.08
Approximate Weight	Grams	Ounces
	170	6.0

Nominal Voltage		1.2V		
Discharge Capacity ¹	Average ²	9000 mAh		
	Rated (Min.)	8250 mAh		
Approx. Internal impedance at 1000Hz at charged state.		3.5mΩ		
Charge	Standard	900mA (0.1It) x 16hrs.		
	Rapid	4500mA (1It) x 2.4 hrs.		
Ambient Temperature	Charge	Standard	°C	°F
			0°C to 45°C	32°F to 113°F
	Rapid ³	0°C to 40°C	32°F to 104°F	
		Discharge	-10°C to 65°C	14°F to 149°F
Storage	< 1 year	-20°C to 35°C	-4°F to 95°F	
	< 6 months	-20°C to 45°C	-4°F to 113°F	

¹ After charging at 0.1It for 16 hours, discharging at 0.2It.

² For reference only.

³ For rapid charge: contact Panasonic for recommended charge control methods.

Battery performance and cycle life are strongly affected by how they are used. In order to maximize battery safety, please consult Panasonic when determining charge / discharge specs, warning label contents and unit design.

Note: [It] was previously expressed as [C]. [It] is an IEC standard expression for the amount of charge or discharge current and is expressed as:

$$It(A) = Cn (Ah)/1h.$$

- [It] is the reference test current in amperes
- [Cn] is the rated capacity of the cell or battery in Ampere-hours.
n = the time base [hours] for which the rated capacity is declared

Typical Discharge Characteristics

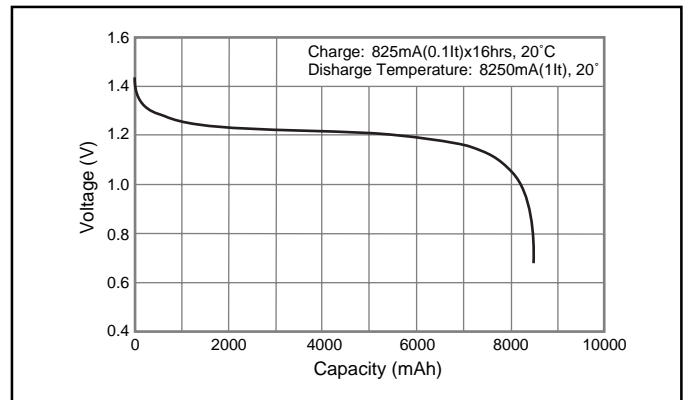
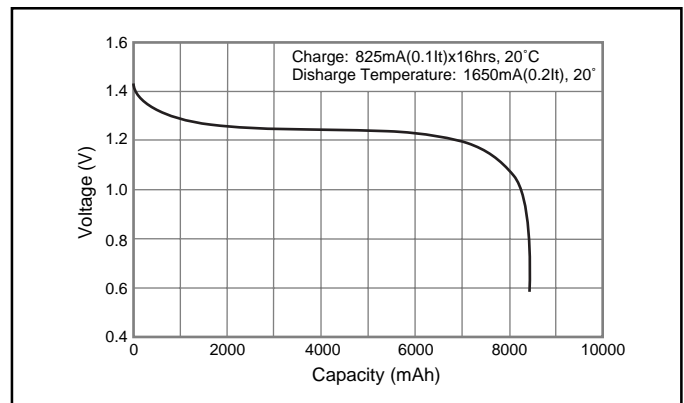
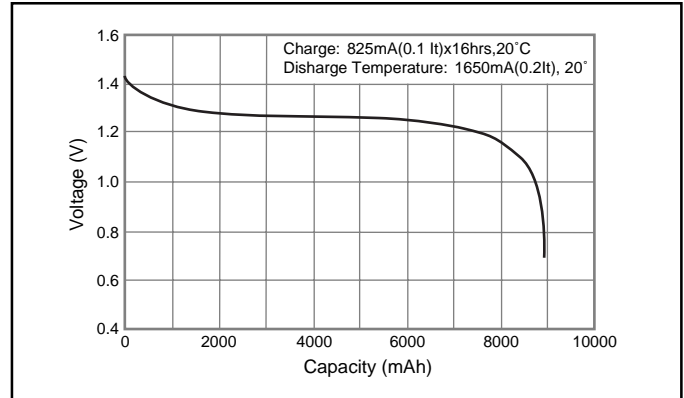

BATTERY PACKS

Purpose of Packs

For the most part, nickel-metal hydride batteries are used in battery packs when installed in products. When these batteries are used, the type of battery, number of cells, shape of the pack, constituent parts of the pack, etc, are determined by the specifications (voltage, load current) of the product. In addition, the charge specifications, space available in the battery

compartment, operating conditions, etc., must also be considered. At Panasonic, we promote battery packs which emphasize the safety and reliability of the batteries. We customize packs that satisfy the unique requirements of each customer. Do not hesitate to contact us regarding your specific needs.

Shapes of Battery Packs (Typical & Standard Types)

F Type

The required number of single cells are arranged side by side along their diameter, connected by nickel plates, and packed together with heat-shrinkable tubing.

Composite F type

Single cells are connected in the F type configuration but in two to five rows rather than one row and packed together by heat-shrinkable tubing.

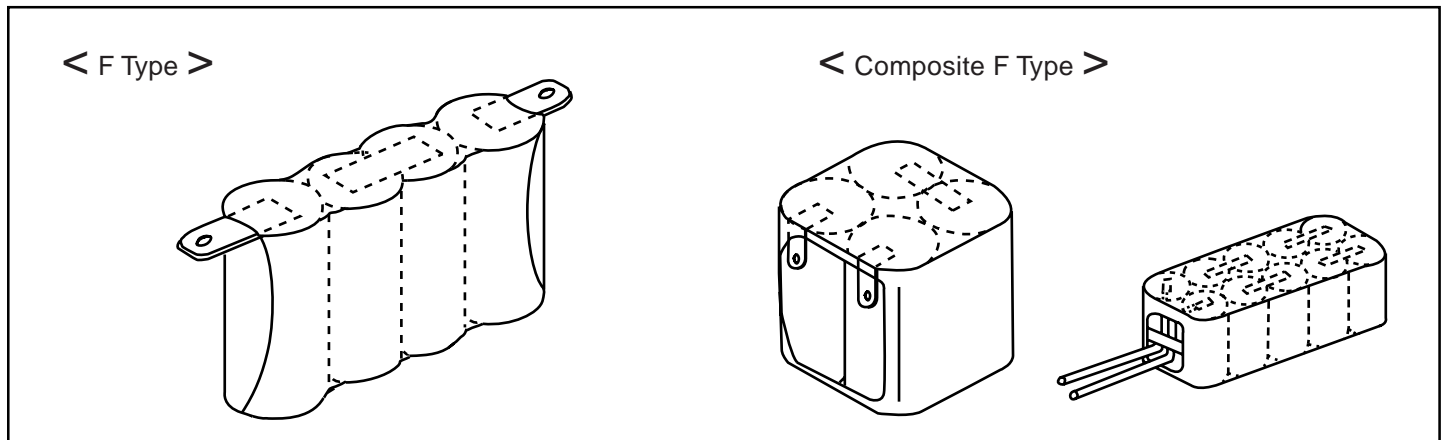

L Type

The required number of single cells are arranged in a line in the axis of the batteries, connected by connecting plates, and packed together by heat-shrinkable tubing.

Composite L Type

Single cells connected in the L type configuration are further connected in two to five rows, and packed together by heat-shrinkable tubing.

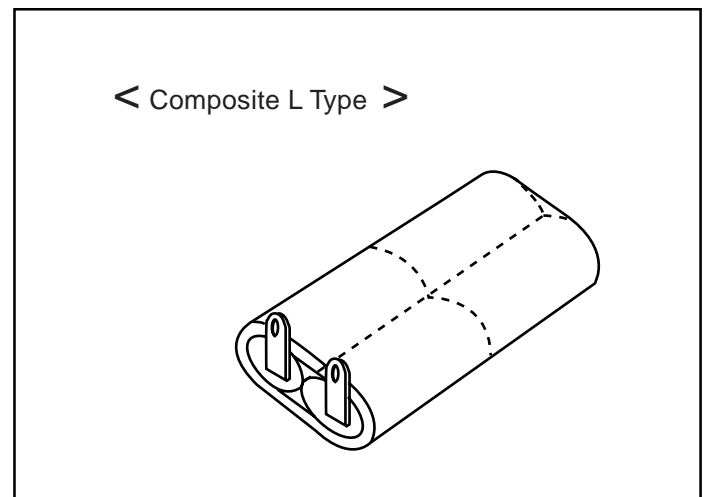

BATTERY PACKS - CONTINUED

Construction of Battery Packs

The figure below shows the basic construction of a battery pack. It is recommended that a thermal protector, which is used for temperature detection and external short-circuiting, be installed in a nickel-metal hydride battery pack to prevent any rise in the temperature of the pack.

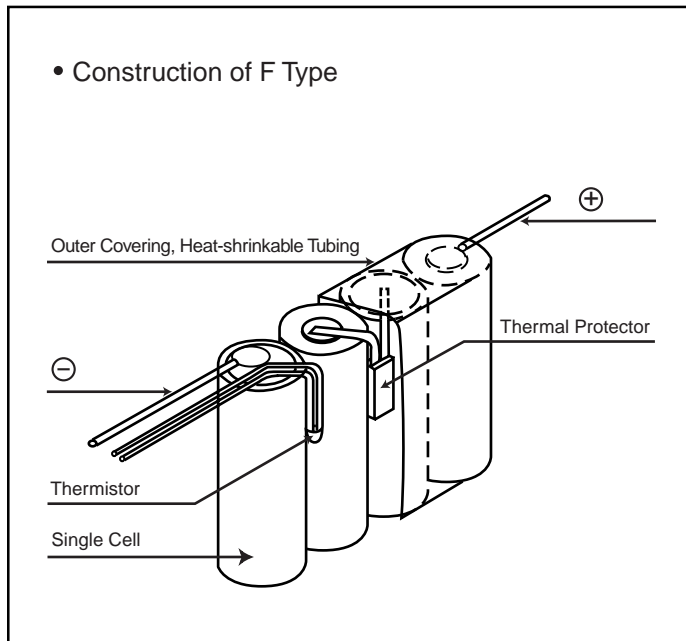

Special Pack Shapes

Panasonic is prepared to meet customers' needs for customized specifications (such as battery packs in plastic resin cases). Please contact Panasonic for detailed discussions concerning specifications, lead times, etc.

When designing battery packs, please consult Panasonic for technical considerations on the following:

- (1) Plastic Resin Pack
Please take into consideration lead-time for tooling and component lead times.
- (2) Packs needing a fuel gauge and battery packs with built-in chargers.

TRANSPORTATION AND DISPOSAL

Disposal

All Panasonic Nickel Metal Hydride batteries are classified by the federal government as a non-hazardous waste and are safe for disposal in the normal municipal waste stream. Exception: California, which requires non-households to dispose of these batteries in accordance with the California Universal Waste Rules. These batteries, however, do contain recyclable materials and are accepted for recycling by the Rechargeable Battery Recycling Corporation's (RBRC) Battery Recycling Program. Please call 1-800-8-BATTERY for information on recycling your used Nickel Metal Hydride battery or go to the RBRC website at www.rbrc.org for additional information.



Transportation

Panasonic sealed Nickel Metal Hydride batteries are considered to be “dry cell” batteries and are unregulated for purposes of transportation by the U.S. Department of Transportation (DOT), International Civil Aviation Administration (ICAO), International Air Transport Association (IATA) and the International Maritime Organization (IMO). The only requirements for shipping these batteries by DOT is Special Provision 130 which states: “Batteries, dry are not subject to the requirements of this subchapter only when they are offered for transportation in a manner that prevents the dangerous evolution of heat (for example, by the effective insulation of exposed terminals). The only requirements for shipping these batteries by ICAO and IATA is Special Provision A123 which states: “An electrical battery or battery powered device having the potential of dangerous evolutions of heat that is not prepared so as to prevent a short-circuit (e.g. in the case of batteries, by the effective insulation of exposed terminals; or in the case of equipment, by disconnection of the battery and protection of exposed terminals) is forbidden from transportation.”

For additional information on the transportation and disposal of batteries, please contact your local Panasonic Battery Sales Group sales office or visit our website at: www.panasonic.com/batteries

- **Active Material**

The electro-chemical materials of the electrodes. In rechargeable Ni-MH battery, nickel-hydroxide is the active material of the positive electrode and hydrogen-absorbing alloy is the active material of the negative electrode.

- **Alkaline Storage Battery**

A storage battery that uses an alkaline water solution as its electrolyte. Generally refers to nickel-metal hydride batteries and nickel-cadmium batteries.

- **C (Coulomb)**

Used to express the amount of the charge or discharge current. Expressed by attaching the current units to a numerical multiple that represents the rated capacity of the battery. The charge and discharge current are generally expressed using a C multiple. For example, for a battery having a rated capacity of 1500 mAh:

$$0.1CmA = 0.1 \times 1500 = 150 \text{ mA}$$

$$0.2CmA = 0.2 \times 1500 = 300 \text{ mA}$$

- **Capacity**

The electrical capacity of a rechargeable battery. Normally used to mean the capacity as measured in ampere-hours. Indicated in units of Ah (Ampere-hours) or C (coulombs).

- **Cell**

Each of the individual batteries which comprise a rechargeable battery.

- **Charge Efficiency**

A general term meaning either ampere-hour efficiency or watt-hour efficiency. More commonly used to mean ampere-hour efficiency.

- **Charge Level**

The amount of electricity used for charge. For constant current charge, it is the product of multiplying the current value by the charge time. Measured in units of ampere-hours (Ah).

- **Cut-off Discharge Voltage**

The voltage that indicates the limit at which discharge is completed. In practical use, this voltage is the limit to which the battery can be used.

- **Cycle Use**

A method of use in which charge and discharge are repeated over and over again.

- **Electrolyte**

The medium through which ions are conducted during the electro-chemical reaction inside a rechargeable battery. In rechargeable Ni-MH battery, a potassium hydroxide water solution is generally used as the electrolyte.

- **Electrolyte Leakage**

The penetration of the electrolyte to the outside of the battery.

- **Energy Density**

The amount of energy that can be obtained per unit weight or per unit volume of a rechargeable battery. Unit: wh/kg, wh/l.

- **Excessive Discharge**

The discharge of a rechargeable battery to lower than the specified cut-off discharge voltage.

- **High Rate Discharge**

Discharge at a relatively large current with respect to the battery capacity. Also called high-efficiency discharge and high-current discharge.

- **Hydrogen-absorbing Alloy**

Alloy which can absorb/release hydrogen reversibly. AB5 or AB2 type alloy is used for batteries. (MmNi5) AB5 type is employed in Panasonic's products.

- **IEC Standards**

The standards established by the International Electrotechnical Commission (IEC).

For nickel-metal hydride batteries there is no standard so the standard for Ni-Cd batteries is generally used for the time being.

- **[It]**

[It] was previously expressed as [C]. [It] is an IEC standard expression for the amount of charge or discharge current and is expressed as:

$$It(A) = Cn (Ah)/1h.$$

- [It] is the reference test current in ampres

- [Cn] is the rated capacity of the cell or battery in Ampere-hours.

n = the time base [hours] for which the rated capacity is declared

[It] (cont.)

All charge and discharge currents will be expressed as fractions or multiples of [It].

Note: 1434 IEC (1996)

In alkaline secondary cell and battery standards and in the industry in general, charge and discharge currents have traditionally been expressed as fractions or multiples of C, where C is the rated capacity of the cell or battery in ampere-hours (Ah). Objections have been raised that to divide or multiply C results in a fraction or multiple of Ah and it is therefore mathematically incorrect to express current (amperes [A]) in this way.

- **Negative Electrode**

The electrode that has a lower electrical potential than the positive electrode to which electrical current flows from the external circuit during the discharge of a storage battery.

- **Nickel Oxyhydroxide**

Expressed in chemical notation as NiOOH, this indicates that the positive electrode material of the Ni-MH battery is in a charged state. When in the discharged state, the positive electrode material becomes nickel hydroxide, or Ni(OH)₂.

- **Nominal Voltage**

The voltage used to indicate the battery voltage. Generally a value slightly lower than the electromotive force is used. For example, the nominal voltage of rechargeable Ni-MH batteries is 1.2 V per cell.

- **Open Circuit Voltage**

The voltage of a battery when that battery is electrically cut-off from the external circuit.

- **Overcharge Current**

Charge after the fully charged state has been reached. In a rechargeable battery that requires water replenishment, the electrolysis of the water causes a sharp decrease in the amount of electrolyte. Generally, the overcharge of a rechargeable battery will shorten the battery's cycle life.

- **Pasted Type Electrode Plate**

An electrode plate made by applying the active material (hydrogen-absorbing compound) in a paste form onto a nickel-plated steel porous plate. Used as the negative electrode.

- **Positive Electrode**

The positive electrode that has a higher electrical potential than the negative electrode from which electrical current flows to the external circuit during the discharge of a rechargeable battery.

- **Rapid Charge**

Charge quickly using a large current.

- **Rated Capacity**

The standard value for the amount of electricity which can be obtained from the battery in a fully charged state at the specified temperature, discharge current, and cut-off discharge voltage. Measured in units of ampere-hours (Ah).

Note that C_N is used as a symbol to express the rated capacity at a rate of N hours.

- **Reverse Charge**

Charge with the polarities reversed. If the polarities are reversed, all of the electrical energy will be used to generate gas.

- **Safety Vent**

Functions to release the gas when the internal pressure exceeds a predetermined level. In addition to preventing the absorption of external air into the rechargeable battery, this vent also prevents the rupture of the rechargeable battery that would result from the increase in the internal pressure caused by the generation of gas during charge or at other times.

- **Self-Discharge**

A decrease in the capacity of a rechargeable battery without any discharge of current to the external circuit.

- **Separator**

A porous or micro-porous thin plate, cloth, bar, or frame which is inserted as a spacer between the positive and negative electrode plates for the purpose of preventing short-circuits. The separator must be non-oxidizing, resistant to chemicals, and be an electrical insulator, and it must not obstruct in any way the ionic conduction or diffusion of the electrolyte.

The separator also functions to retain the electrolyte.

This literature contains information concerning cells and batteries manufactured by Matsushita Battery Industrial Co., Ltd. This information is generally descriptive only and is not intended to make or imply any representation guarantee or warranty with respect to any cells and batteries. Cell and battery designs are subject to modification without notice. Contact Panasonic for safety precautions and the latest specifications before purchase and/or use. © 2005 Copyright Matsushita Battery Industrial Co., Ltd. All rights reserved.

Panasonic Industrial Company
A Division of Panasonic Corporation of North America
Toll Free: 877-726-2228
E-mail: oembatteries@us.panasonic.com
Web: www.panasonic.com/batteries