

Specialty Polymer Aluminum Electrolytic Capacitors

SP-Cap
Specialty Polymer Capacitor

TECHNICAL GUIDE

Standard products (FD/CD/UD/UE series)
Lower ESR products (SL/SX/SD/SE series)
High Temp. products (HL/HD/HE series)

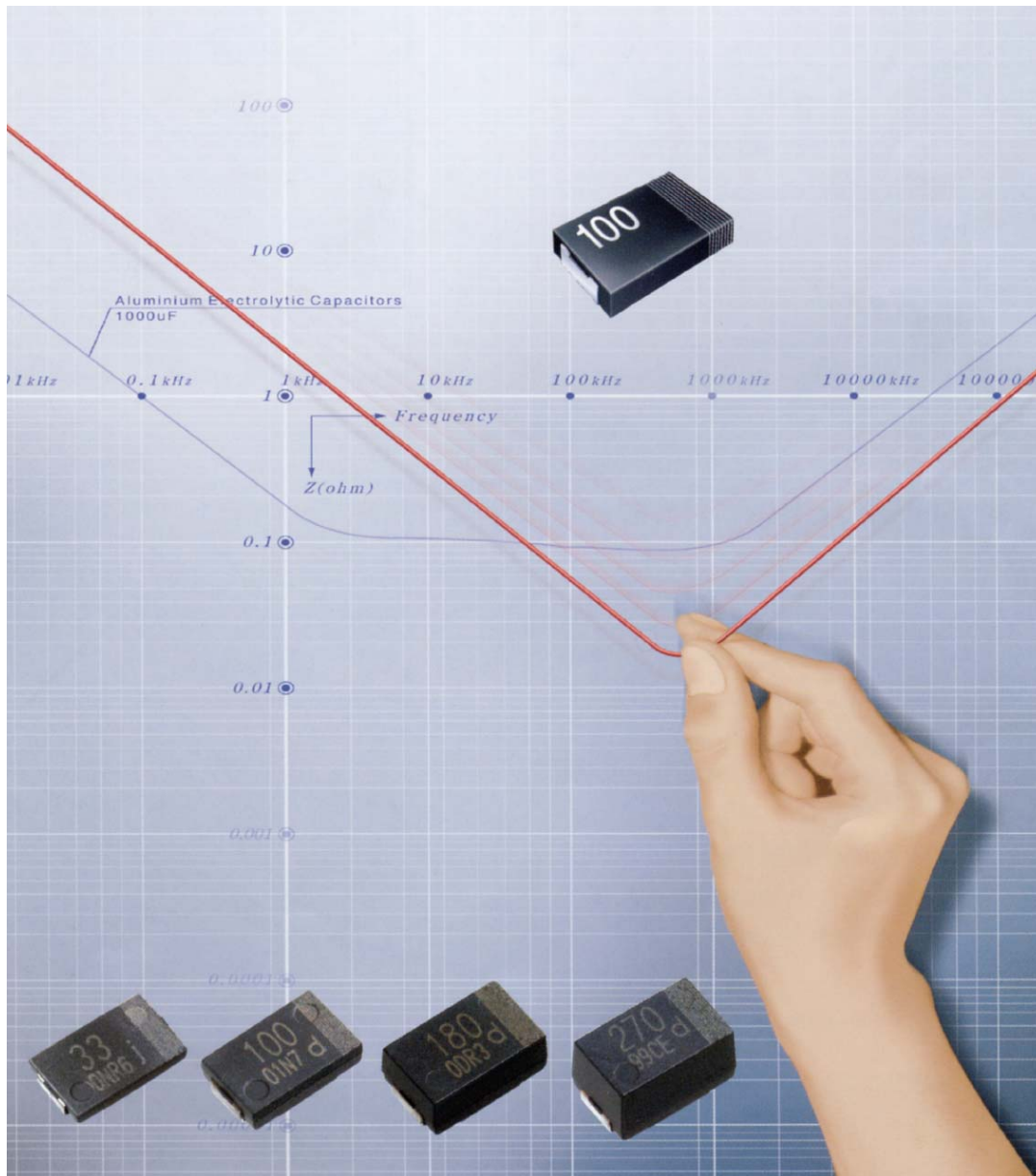



Panasonic Industrial Company

2 Panasonic Way
Secaucus, NJ 07094
1-800-344-2112

<http://www.panasonic.com/pic/ecg>

■ Construction and Product Range

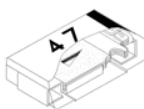
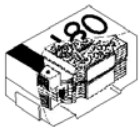
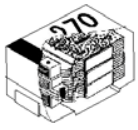
(General Purpose)

W.V. (V. DC)	Construction				
		CD 7.3 x 4.3 x 1.8	UD 7.3 x 4.3 x 2.8	UE 7.3 x 4.3 x 4.2	FD 7.3 x 4.3 x 1.1
2	Capacitance ESR Ripple current	100~150 μ F 18 m Ω 2500 mA	180~330 μ F 9~15 m Ω 3000~3400 mA	270~470 μ F 7~12 m Ω 3300~3700 mA	68 μ F 28 m Ω 2000 mA
2.5	Capacitance ESR Ripple current	82~120 μ F 18 m Ω 2500 mA	150~270 μ F 9~15 m Ω 3000~3400 mA	220~390 μ F 7~12 m Ω 3300~3700 mA	56 μ F 28 m Ω 2000 mA
4	Capacitance ESR Ripple current	56~100 μ F 18~25 m Ω 1800~2500 mA	120~180 μ F 9~18 m Ω 2500~3400 mA	180~270 μ F 7~12 m Ω 3000~3700 mA	39~47 μ F 28 m Ω 2000 mA
6.3	Capacitance ESR Ripple current	10~68 μ F 18~55 m Ω 1400~2500 mA	100~150 μ F 9~18 m Ω 2500~3400 mA	150~220 μ F 7~15 m Ω 3000~3700 mA	33 μ F 28 m Ω 2000 mA
8	Capacitance ESR Ripple current	8.2~47 μ F 18~55 m Ω 1400~2500 mA	68~100 μ F 15~18 m Ω 2500~3000 mA	100~150 μ F 12~15 m Ω 3000~3300 mA	22 μ F 28 m Ω 2000 mA
12.5	Capacitance ESR Ripple current	4.7~22 μ F 30~80 m Ω 1000~1600 mA	— — —	— — —	15 μ F 40 m Ω 1400 mA
16	Capacitance ESR Ripple current	2.2~8.2 μ F 45~110 m Ω 1000~1300 mA	— — —	— — —	— — —

S-Series

(Low ESR/High Ripple)



W.V. (V. DC)	Size (Series)	SL/SX	SD	SE
		7.3 x 4.3 x 1.8 7.3 x 4.3 x 2.0	7.3 x 4.3 x 2.8	7.3 x 4.3 x 4.2
2	Capacitance ESR Ripple current	100~220 μ F 9 m Ω 3000 mA	270~390 μ F 7 m Ω 3500 mA	390~560 μ F 5 m Ω 4000 mA
2.5	Capacitance ESR Ripple current	100/180 μ F 9 m Ω 3000 mA	220/270 μ F 7 m Ω 3500 mA	330/390 μ F 5 m Ω 4000 mA
4	Capacitance ESR Ripple current	82/100 μ F 9 m Ω 3000 mA	150 μ F 7 m Ω 3500 mA	220 μ F 5 m Ω 4000 mA
6.3	Capacitance ESR Ripple current	56/68 μ F 9 m Ω 3000 mA	120 μ F 7 m Ω 3500 mA	180 μ F 5 m Ω 4000 mA
8	Capacitance ESR Ripple current	— — —	— — —	— — —
12.5	Capacitance ESR Ripple current	— — —	— — —	— — —
16	Capacitance ESR Ripple current	— — —	— — —	— — —

H-Series 125°C

(High Reliability)



	HL	HD	HE
	7.3x4.3x1.8	7.3x4.3x2.8	7.3x4.3x4.2
	100 μ F 18 m Ω 1800 mA	180/220 μ F 15 m Ω 2200 mA	270/330 μ F 12 m Ω 3000 mA
	82 μ F 18 m Ω 1800 mA	150/180 μ F 15 m Ω 2200 mA	220/270 μ F 12 m Ω 3000 mA
	56~68 μ F 18 m Ω 1800 mA	120 μ F 15 m Ω 2200 mA	180 μ F 12 m Ω 3000 mA
	47 μ F 18 m Ω 1800 mA	100 μ F 15 m Ω 2200 mA	150 μ F 12 m Ω 3000 mA
	33 μ F 18 m Ω 1800 mA	68 μ F 15 m Ω 2200 mA	100 μ F 12 m Ω 3000 mA
	— — —	— — —	— — —
	— — —	— — —	— — —

ESR spec at 100kHz/20°C (m Ω max.)
Ripple current at 100kHz/105°C (max. mA rms)



Table of Contents

	Page No.	
1 Features	4 - 7	1
Exclusive features: SP-Cap.....	4	2
Comparison with other types of capacitors.....	5	
Example of simulation.....	7	
2 Outline of Products	8 - 10	3
Very low ESR.....	8	
Product structure.....	8	
Product Line-up	9	
Product tables.....	10	4
3 Product Lists	11	
4 Product Specifications	14	5
5 Application Guidelines (<i>READ THOROUGHLY</i>).....	17	
6 Packaging Specifications	19	6
7 Soldering Specifications	20	
8 Reference Land-pattern	20	7
9 Special Capabilities	21 - 23	8
Excellent noise absorption.....	21	
Excellent ripple voltage reduction.....	22	
Excellent transient response	23	9
10 Transient Response Simulation	24 - 28	
Application example (CPU).....	24	
Simulation method.....	26	
Estimation of capacitance-frequency characteristics using the Ladder model	28	10
11 Safety and Reliability	29 - 33	
Safety.....	29	
Why is the capacitor difficult to smoke and ignite?.....	30	11
Reliability.....	31	
The SP-cap is difficult to short-circuit.....	32	
12 Data	33 - 54	
Frequency characteristics.....	33 - 48	12
Temperature characteristics.....	49	
Endurance.....	50	
Shelf Life (with no load at +105°C).....	51	
Damp heat, Steady State (with no load at +60°C, 90%R.H.).....	52	
Surge voltage.....	53	
Resistance to soldering heat.....	54	



Exclusive features: SP-Cap

- **Very low ESR (Equivalent Series Resistance) characteristics**

The specialty polymer capacitor has very low ESR characteristics which allows it to have rapid current discharge capability. This makes the SP-Cap an excellent choice as a bulk capacitor in CPU applications.

- **Very low impedance characteristics**

- **Stable capacitance characteristics**

The specialty polymer capacitor has stable capacitance characteristics versus changes in the operating temperature and frequency.

- **Voltage derating not required for standard product**

The specialty polymer capacitor usually can be operated at full rated voltage. Voltage derating may be required depending on the operating temperature. (125°C rated product)

- **Stable temperature characteristics**

The specialty polymer capacitor has stable capacitance and ESR characteristics versus changes in operating temperature.

- **High safety taking full advantage of the material**

More difficult to ignite and "smoke" than a tantalum electrolytic capacitor.

- **Surface mounting and reduced height**

With the adoption of our exclusive new structure, surface mounting and a reduction in height have been achieved.



Comparison with other types of capacitors

Very low ESR and large capacitance

ESR: Approx. 1/10 or less than that of a tantalum capacitor
 Capacitance: Approx. 3 times or more than that of a ceramic capacitor

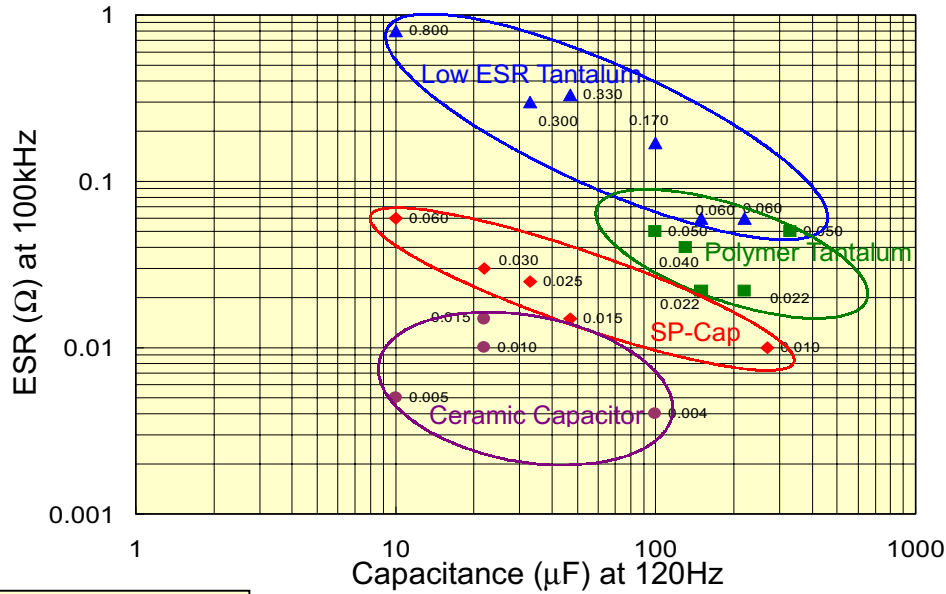

Very low impedance

Lowest impedance among electrolytic capacitors

- (1) SP-Cap (SL series) 2V100μF
- (2) Polymer Tantalum capacitor 4V100μF
- (3) Ceramic capacitor 6.3V100μF
- (4) Low ESR Tantalum capacitor 10V100μF

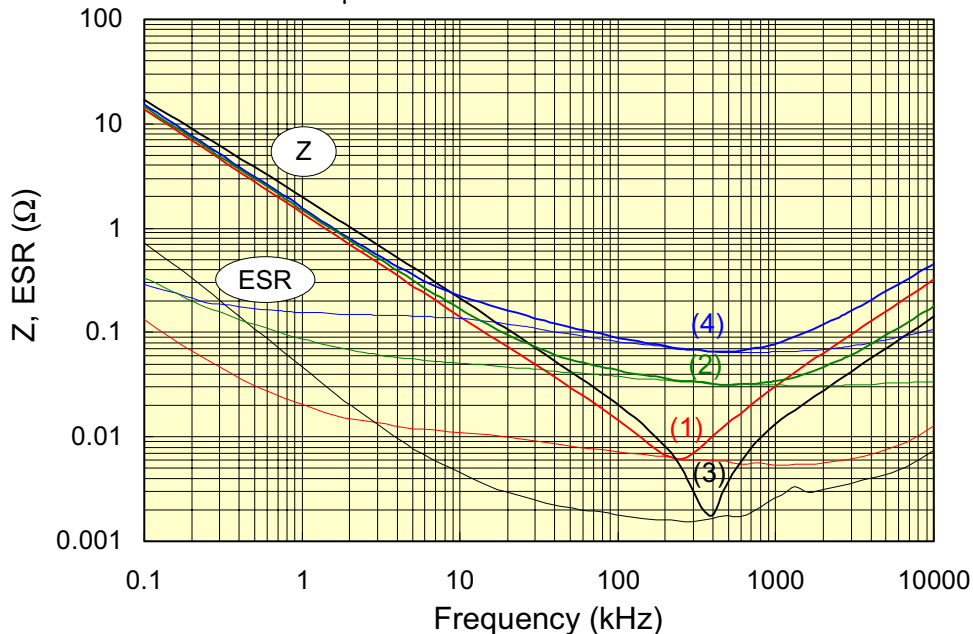



■ Stable capacitance*

- (1) SP-Cap (SL series)
2V100 μ F
- (3) Ceramic capacitor
6.3V100 μ F

- (2) Polymer Tantalum capacitor
4V100 μ F
- (4) Low ESR Tantalum capacitor
10V100 μ F

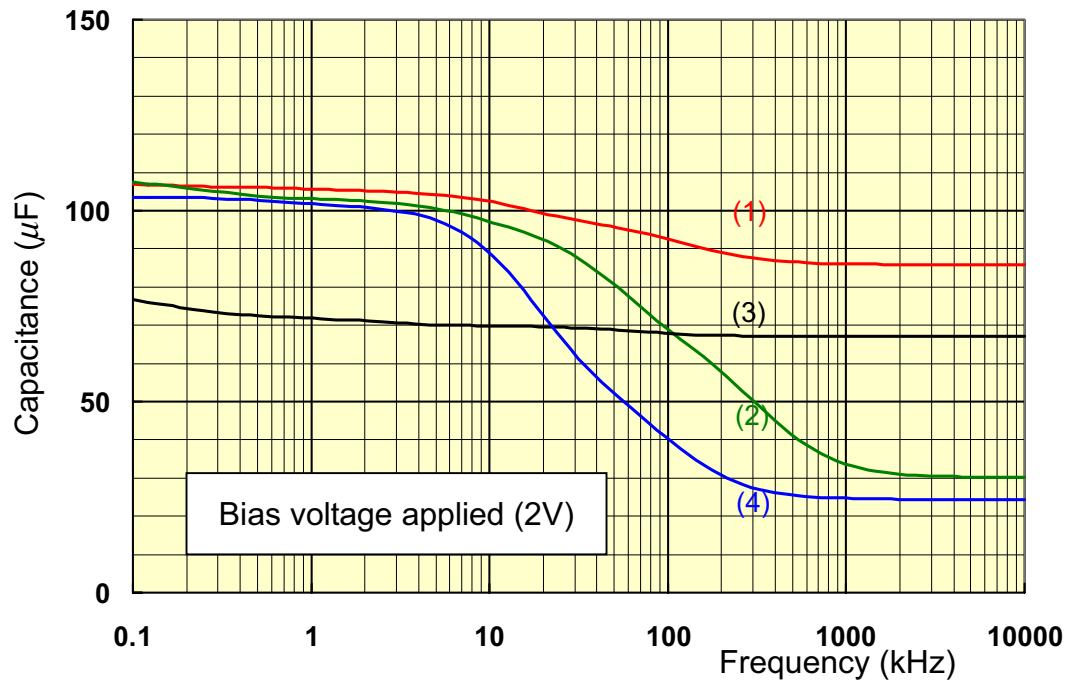
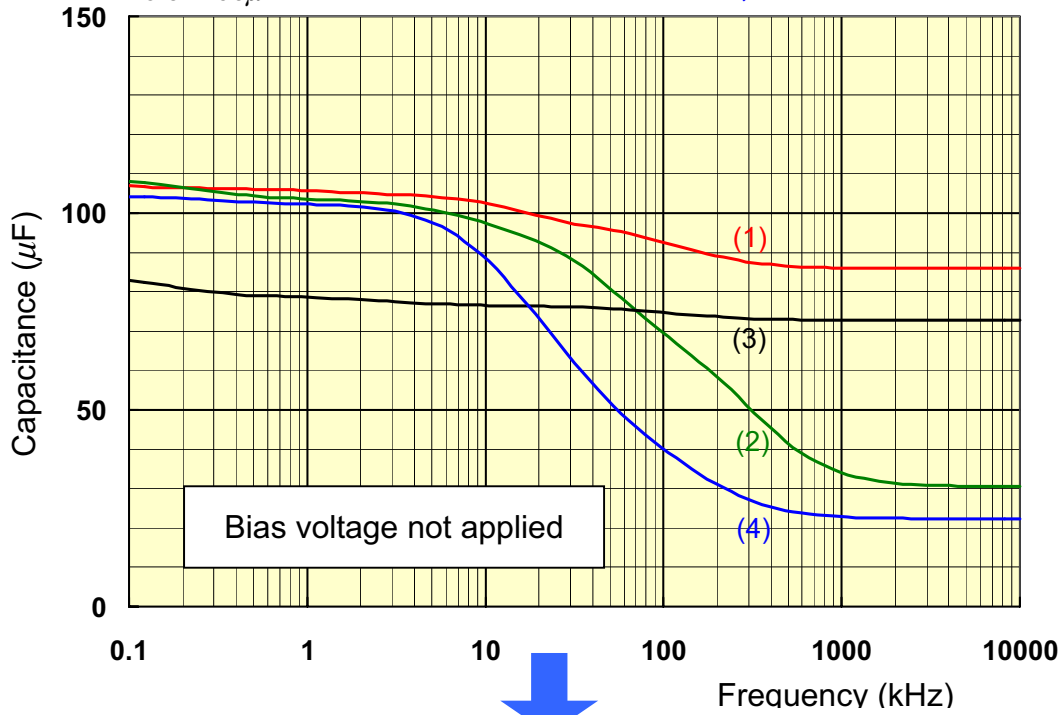

* Please refer to 'Estimation of capacitance-frequency characteristics using the Ladder model'



Example of simulation

SP-AL can replace MLCC!
 3 pcs of EEFC0D0101R(2V100 μ F) can replace 30 pcs of MLCC 6.3V10 μ F Y5V 1206.

Circuit conditions

- Vin 11.4V
- Vout 1.75V
- Ip-p 60A
(Imax:70A Imin:10A)
- CPU slew rate 40A/ μ s
- Vp-p 140mV
(Transient Resp.+/-25mV)
- Switching Freq. 200kHz x3phase(=600kHz)
- Inductance 1.1 μ H
- Target CPU **Desktop P4 Northwood**

Current behavior of CPU and Power Supply

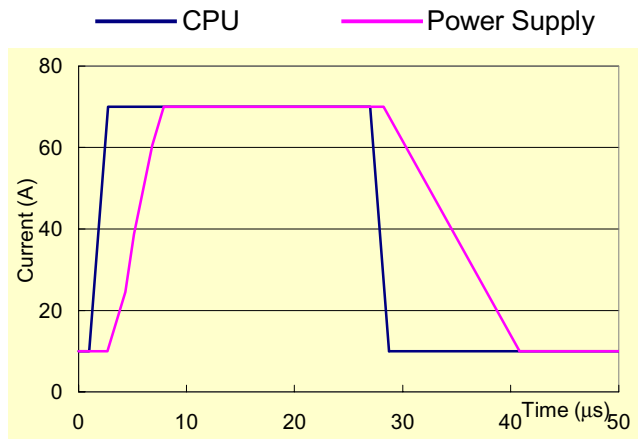

Transient response simulation results

Droop

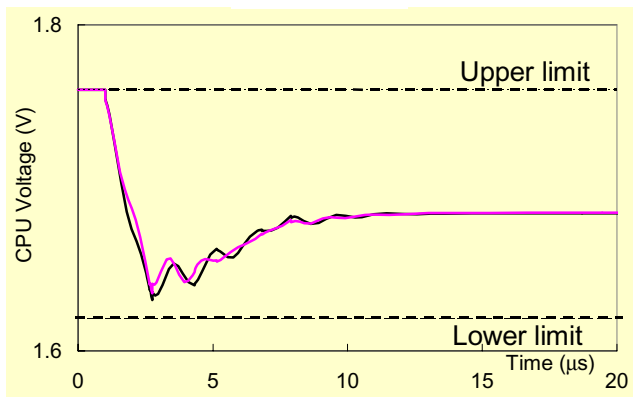

Overshoot

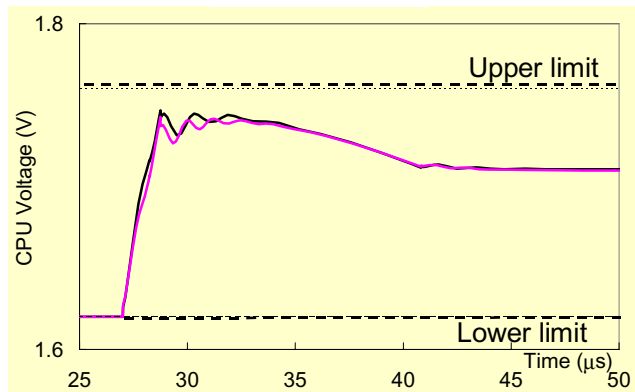

Line	Capacitor solution	Droop	Overshoot
	Bulk Capacitors: (A-FJ6.3V1500 μ F x8 + OS 4V510 μ F x4)		
—	Bulk Capacitors + MLCC1206(Y5V)10 μ F x38	129mV	127mV
—	Bulk Capacitors + SP-Cap CD2V100 μ F x3 + MLCC1206(Y5V)10 μ F x8	125mV	123mV



Outline of Products

Very low ESR

- In order to reduce ESR, the electrical conductivity of the electrolyte (cathode material) must be increased.
- The specialty polymer electrolyte has a conductivity higher than that of conventional electrolytes
 - * Approx. 10,000 times that of an aluminum capacitor (electrolyte : liquid)
 - * Approx. 1,000 times that of a tantalum capacitor (manganese dioxide : solid)



Basic configuration of an electrolytic capacitor

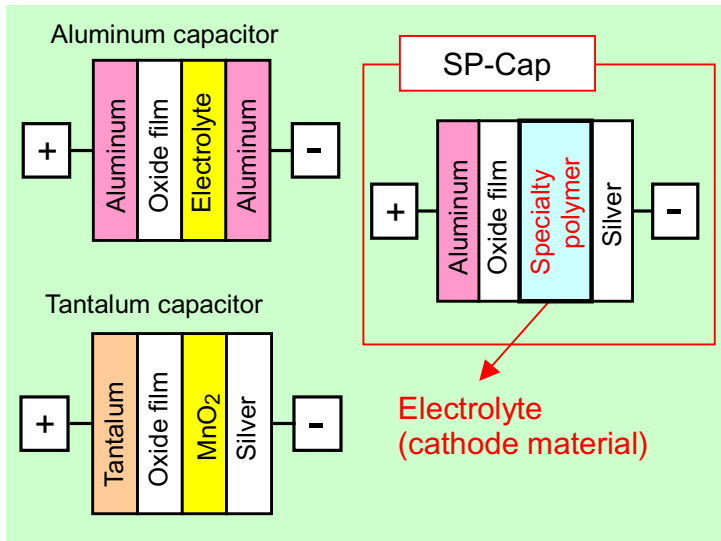

Conductivity of various types of electrolytes

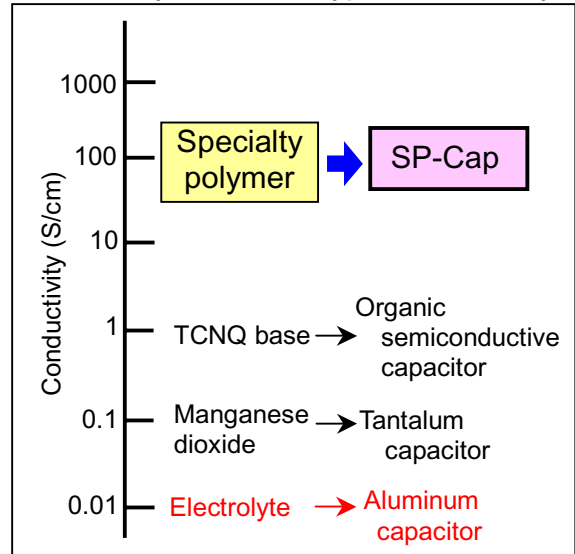

Product structure

With the adoption of our exclusive structure, surface mounting and reduced height have been achieved.

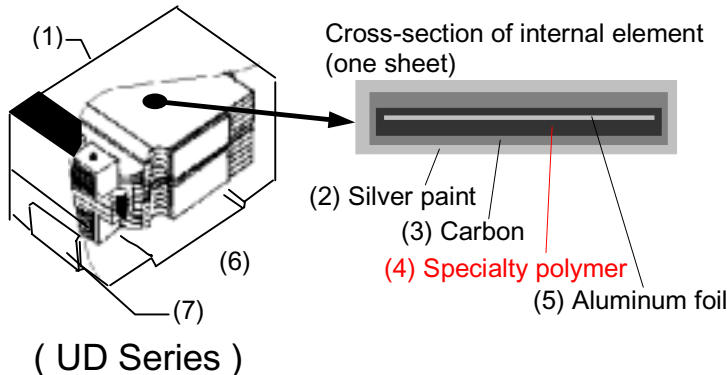

No	Component
(1)	Mold resin
(2)	Silver paint
(3)	Carbon
(4)	Specialty polymer
(5)	Aluminum foil
(6)	Internal terminal
(7)	External terminal



Product Line-up

Can easily replace tantalum capacitors due to its standardized D case size and same land pattern (7.3 x 4.3 mm).

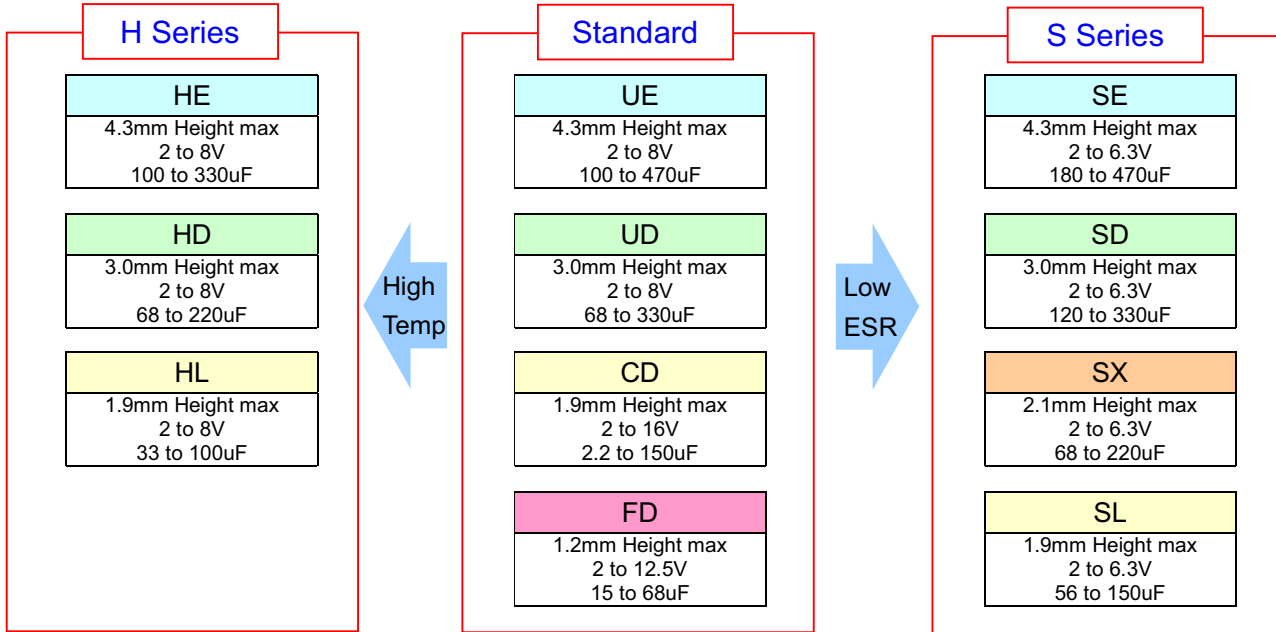

Marking

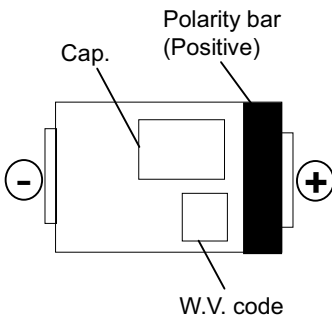

Dimensions in mm (not to scale)

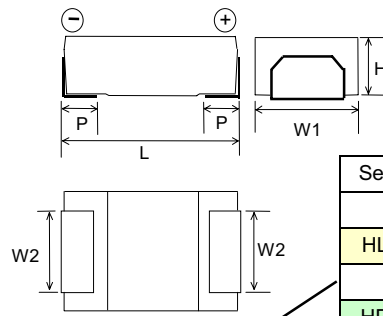

Series & Size code	L	W1	W2	H	P
FD	7.3 ±0.2	4.3 ±0.2	2.4 ±0.1	1.1±0.1	1.3 ±0.3
HL CD SL				1.8±0.1	
SX				1.9±0.2	
HD UD SD				2.8±0.2	
HE UE SE				4.2±0.1	

Part number notation method

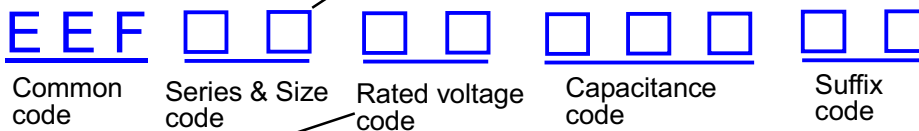

Rated voltage code	Rated voltage
0D	2
0E	2.5
0G	4
0J	6.3
0K	8
1B	12.5
1C	16

Indicated Capacitance in μF by 3 letters. The 1st 2 figures are actual values and the 3rd denotes the number of zeros. "R" denotes the decimal point and all figures are the actual number with "R"
ex: 4.7 μF ---- 4R7 10 μF ---- 100

Suffix code	Specifications
R	Taping
LR	Lower ESR & Taping



Product tables

■ Standard products

ESR values: mΩ at 100kHz/20°C

μF \ V.DC	2 (0D)			2.5 (0E)			4 (0G)			6.3 (0J)			8 (0K)			12.5 (1B)			16 (1C)		
	Series	R	LR	Series	R	LR	Series	R	LR	Series	R	LR	Series	R	LR	Series	R	LR	Series	R	LR
2.2(2R2)																				CD	110
4.7(4R7)																				CD	80
6.8(6R8)																				CD	70
8.2(8R2)																				CD	45
10(100)																				CD	60
15(150)																				FD	40
																				CD	50
22(220)																				CD	30
																				CD	28
33(330)																				FD	28
																				CD	18
39(390)																				FD	28
47(470)																				FD	28
56(560)																				CD	18
68(680)																				CD	18
82(820)																				UD	15
100(101)																				CD	18
																				CD	18
																				CD	25
																				UD	15
																				UD	18
																				UE	12
120(121)																				CD	18
																				CD	18
																				UD	15
150(151)																				UD	15
																				UD	15
																				UE	12
180(181)																				UD	15
																				UD	15
																				UE	12
																				UE	12
220(221)																				UE	12
																				UE	12
270(271)																				UD	15
																				UE	12
																				UE	12
330(331)																				UD	15
																				UE	12
																				UE	12
390(391)																				UE	12
																				UE	12
470(471)																				UE	12

ESR(mΩ 100kHz, 20°C)
RC <Ripple Current >
(Ar.m.s. 100kHz, 105°C)

	ESR	RC
FD	40 mΩ	1.4 Ar.m.s.
	28 mΩ	2.0 Ar.m.s.
CD	110 mΩ	1.0 Ar.m.s.
	80 mΩ	1.0 Ar.m.s.
	70 mΩ	1.0 Ar.m.s.
	60 mΩ	1.0 Ar.m.s.
	55 mΩ	1.4 Ar.m.s.
	50 mΩ	1.3 Ar.m.s.
	45 mΩ	1.3 Ar.m.s.
	40 mΩ	1.6 Ar.m.s.
	30 mΩ	1.6 Ar.m.s.
	28 mΩ	2.0 Ar.m.s.
	25 mΩ	1.8 Ar.m.s.
	18 mΩ	2.5 Ar.m.s.
	15 mΩ	2.7 Ar.m.s.
UD	18 mΩ	2.5 Ar.m.s.
	15 mΩ	3.0 Ar.m.s.
	12 mΩ	3.3 Ar.m.s.
	9 mΩ	3.4 Ar.m.s.
UE	15 mΩ	3.0 Ar.m.s.
	12 mΩ	3.3 Ar.m.s.
	10 mΩ	3.5 Ar.m.s.
	7 mΩ	3.7 Ar.m.s.

■ S series products

μF \ V.DC	2 (0D)	2.5 (0E)	4 (0G)	6.3 (0J)
56(560)				SL
68(680)				SX
82(820)			SL SX	
100(101)	SL	SL	SX	
120(121)	SL	SL		SD
150(151)	SL	SX	SD	
180(181)	SL SX	SX		SE
220(221)	SX	SD	SE	
270(271)	SD	SD		
330(331)	SD	SE		
390(391)	SD SE	SE		
470(471)	SE			
560(561)	SE			

(100kHz)	ESR(20°C)	Ripple Current (105°C)
SL	9 mΩ	3.0 Ar.m.s.
SX	9 mΩ	3.0 Ar.m.s.
SD	7 mΩ	3.5 Ar.m.s.
SE	5 mΩ	4.0 Ar.m.s.

■ H series products

μF \ V.DC	2 (0D)	2.5 (0E)	4 (0G)	6.3 (0J)	8 (0K)
33(330)					HL
47(470)				HL	
56(560)			HL		
68(680)			HL		HD
82(820)		HL			
100(101)	HL			HD	HE
120(121)			HD		
150(151)		HD		HE	
180(181)	HD	HD	HE		
220(221)	HD	HE			
270(271)	HE	HE			
330(331)	HE				

(100kHz)	ESR(20°C)	Ripple Current (125°C)
HL	18 mΩ	1.8 Ar.m.s.
HD	15 mΩ	2.5 Ar.m.s.
HE	12 mΩ	3.0 Ar.m.s.

() shows W.V. and capacitance code.



Product Lists

■ Standard products

*1: 100kHz/ 20 to 105°C

Series & Size code	Part number	Rated Voltage (V.DC)	Cap. (μF)	tanδ max.	L.C. max. (μA)	ESR(mT) max (100kHz,20°C)	Permissible Ripple Current (A r.m.s)*1
FD	EEFFD0D680R	2	68	0.06	8.1	28	2.0
	EEFFD0E560R	2.5	56		8.4		
	EEFFD0G390R	4	39		9.3		
	EEFFD0G470R		47		11.2		
	EEFFD0J330R	6.3	33		8.3		
	EEFFD0K220R	8	22		7.0		
	EEFFD1B150R	12.5	15		7.5		
	CD	EEFCD0D101R	2		100	0.06	12.0
EEFCD0D121R		120		14.4	18		2.5
EEFCD0D151R		150		18.0	18		2.5
EEFCD0E820R		2.5	82	12.3	18		2.5
EEFCD0E101R			100	15.0	18		2.5
EEFCD0E121R			120	18.0	18		2.5
EEFCD0G560R		4	56	13.4	18		2.5
EEFCD0G680R			68	16.3	18		2.5
EEFCD0G820R			82	19.6	18		2.5
EEFCD0G101R			100	24.0	25		1.8
EEFCD0J100R		6.3	10	3.0	55		1.4
EEFCD0J220R			22	5.5	40		1.6
EEFCD0J330R			33	8.3	28		2.0
EEFCD0J470R			47	11.8	18		2.5
EEFCD0J680R			68	17.1	18		2.5
EEFCD0K8R2R		8	8.2	3.0	55		1.4
EEFCD0K150R			15	4.8	40		1.6
EEFCD0K220R			22	7.0	28		2.0
EEFCD0K330R			33	10.5	18		2.5
EEFCD0K470R			47	15.0	25		2.5
EEFCD1B4R7R		12.5	4.7	3.0	80		1.0
EEFCD1B100R			10	5.0	60		1.0
EEFCD1B150R			15	7.5	50		1.3
EEFCD1B220R			22	11.0	30		1.6
EEFCD1C2R2R		16	2.2	3.0	110		1.0
EEFCD1C4R7R			4.7	3.0	80		
EEFCD1C6R8R			6.8	4.3	70		
EEFCD1C8R2R			8.2	5.2	45		





■ Standard products

*1: 100kHz/ 20 to 105°C

Series & Size code	Part number	Rated Voltage (V.DC)	Cap. (μF)	tanδ max.	L.C. max. (μA)	ESR(mΩ) max (100kHz,20°C)	Permissible Ripple Current (A r.m.s)*1
UD	EEFUD0D181R	2	180	0.1	21.6	15	3.0
	EEFUD0D221R		220		26.4	15	3.0
	EEFUD0D271R		270		32.4	15	3.0
	EEFUD0D271LR		270		32.4	9	3.4
	EEFUD0D331R		330		39.6	15	3.0
	EEFUD0D331LR		330		39.6	9	3.4
	EEFUD0E151R	2.5	150		22.5	15	3.0
	EEFUD0E181R		180		27.0	15	3.0
	EEFUD0E221R		220		33.0	15	3.0
	EEFUD0E221LR		220		33.0	9	3.4
	EEFUD0E271R		270		40.5	15	3.0
	EEFUD0E271LR		270		40.5	9	3.4
	EEFUD0G121R	4	120		28.8	15	3.0
	EEFUD0G151R		150		36.0	15	3.0
	EEFUD0G151LR		150		36.0	9	3.4
	EEFUD0G181R		180		43.2	18	2.5
	EEFUD0J101R	6.3	100		25.2	15	3.0
	EEFUD0J121R		120		30.2	15	3.0
EEFUD0J121LR	120		30.2	9	3.4		
EEFUD0J151R	150		37.8	18	2.5		
EEFUD0K680R	8	68	21.7	15	3.0		
EEFUD0K101R		100	32.0	18	2.5		
UE	EEFUE0D271R	2	270	0.1	32.4	12	3.3
	EEFUE0D331R		330		39.6	12	3.3
	EEFUE0D391R		390		46.8	12	3.3
	EEFUE0D391LR		390		46.8	7	3.7
	EEFUE0D471R		470		56.4	12	3.3
	EEFUE0D471LR		470		56.4	7	3.7
	EEFUE0E221R	2.5	220		33.0	12	3.3
	EEFUE0E271R		270		40.5	12	3.3
	EEFUE0E331R		330		49.5	12	3.3
	EEFUE0E331LR		330		49.5	7	3.7
	EEFUE0E391R		390		58.5	12	3.3
	EEFUE0E391LR		390		58.5	7	3.7
	EEFUE0G181R	4	180		43.2	12	3.3
	EEFUE0G221R		220		52.8	12	3.3
	EEFUE0G221LR		220		52.8	7	3.7
	EEFUE0G271R		270		64.8	15	3.0
	EEFUE0J151R	6.3	150		37.8	12	3.3
	EEFUE0J181R		180		45.3	12	3.3
EEFUE0J181LR	180		45.3	7	3.7		
EEFUE0J221R	220		55.4	15	3.0		
EEFUE0K101R	8	100	32.0	12	3.3		
EEFUE0K151R		150	48.0	15	3.0		



■ S series products

*1: 100kHz/ 20 to 105°C

Size & Size code	Part number	Rated Voltage (V.DC)	Cap. (μF)	tanδ max.	L.C. (μA) max.	ESR(mΩ) (100kHz, 20°C)max.	Permissible Ripple Current (A r.m.s)*1
SL	EEFSL0D101R	2	100	0.06	12.0	9	3.0
	EEFSL0D121R		120		14.4		
	EEFSL0D151R		150		18.0		
	EEFSL0D181R		180		21.6		
	EEFSL0E101R	2.5	100		15.0		
	EEFSL0E121R		120		18.0		
	EEFSL0G820R	4	82		19.7		
	EEFSL0J560R	6.3	56		14.1		
SX	EEFSX0D181R	2	180	0.06	21.6	9	3.0
	EEFSX0D221R		220		26.4		
	EEFSX0E151R	2.5	150		22.5		
	EEFSX0E181R		180		27.0		
	EEFSX0G820R	4	82		19.7		
	EEFSX0G101R		100		24.0		
	EEFSX0J680R	6.3	68		17.1		
	SD	EEFSD0D271R	2		270		
EEFSD0D331R		330		39.6			
EEFSD0D391R		390		46.8			
EEFSD0E221R		2.5	220	33.0			
EEFSD0E271R			270	40.5			
EEFSD0G151R		4	150	36.0			
EEFSD0J121R		6.3	120	30.2			
SE		EEFSE0D391R	2	390	0.10	46.8	5
	EEFSE0D471R	470		56.4			
	EEFSE0D561R	560		67.2			
	EEFSE0E331R	2.5	330	49.5			
	EEFSE0E391R		390	58.5			
	EEFSE0G221R	4	220	52.8			
	EEFSE0J181R	6.3	180	45.3			

■ H series products

*2: 100kHz/ 20 to 125°C

Size & Size code	Part number	Rated Voltage (V.DC)	Cap. (μF)	tanδ max.	L.C. (μA) max.	ESR(mΩ) (100kHz, 20°C)max.	Permissible Ripple Current (A r.m.s)*2
HL	EEFHL0D101R	2	100	0.06	20.0	18	1.8
	EEFHL0E820R	2.5	82		20.5		
	EEFHL0G560R	4	56		22.4		
	EEFHL0G680R		68		27.2		
	EEFHL0J470R	6.3	47		29.6		
	EEFHL0K330R	8	33		26.4		
HD	EEFHD0D181R	2	180	0.10	36.0	15	2.5
	EEFHD0D221R		220		44.0		
	EEFHD0E151R	2.5	150		37.5		
	EEFHD0E181R		180		45.0		
	EEFHD0G121R	4	120		48.0		
	EEFHD0J101R	6.3	100		63.0		
	EEFHD0K680R	8	68		54.4		
HE	EEFHD0D271R	2	270	0.10	54.0	12	3.0
	EEFHD0D331R		330		66.0		
	EEFHD0E221R	2.5	220		55.0		
	EEFHD0E271R		270		67.5		
	EEFHD0G181R	4	180		72.0		
	EEFHD0J151R	6.3	150		94.5		
	EEFHD0K101R	8	100		80.0		





Product Specifications

No	Item	Characteristics		Outline of test method
1	Leakage current	(Standard) (S series) 2V to 4V $I \leq 0.06CV(\mu A)$ or $3\mu A$ 6.3V to 16V $I \leq 0.04CV(\mu A)$ or $3\mu A$ (Whichever is the greater) (H series) $I \leq 0.1CV(\mu A)$	Series resistor: 1000Ω Applied voltage: Rated Voltage Measuring: 2-minutes If you have any concerns about leakage current, please conduct pre-conditioning. Pre-conditioning · Temperature: $105^\circ C$ · Series resistor: 1000Ω · Applied voltage: Rated Voltage · Charge time: 1h · Measuring : The tests in Sub-clause 1 shall be made after discharging the capacitors and storing them for a period of 24h to 48h at room temperature and low humidity.	
2	Capacitance tolerance	$\pm 20\%$		Measuring frequency: $120Hz \pm 10\%$ Measuring circuit: Equivalent series circuit
3	$\tan \delta$	See "Product Lists"		Measuring voltage: $+0.7$ to $1.0V.DC, \leq 0.5V_{rms}$ Measuring temperature: $20^\circ C$
4	ESR	See "Product Lists"		Measuring frequency: $100KHz \pm 10\%$ Measuring voltage: $+0.7$ to $1.0V.DC, \leq 0.5V_{rms}$ Measuring temperature: $20^\circ C$
5	Solderability	More than 75% of the terminal face to be covered by new solder.		Solder type: H60A or H63A Flux: About 25% rosin density melted ethanol. Solder temperature: $230 \pm 5^\circ C$ Immersing time: $2 \pm 0.5s$
6	Solubility resistance of marking	Appearance: No noticeable abnormal change shall occur.		Class of reagent: Extra grade 2-propanol (JIS K8839) or superior. Test temperature: 20 to $25^\circ C$ Immersing time: $30 \pm 5s$
7	Solder heat resistance	Leakage Current	\leq The value of item 1.	The capacitor is heated to and held at $235 \pm 5^\circ C$ in a high temperature oven for $200 \pm 10s$. Measurements of the following performance characteristics are made after the capacitor cools to room temperature.
		Capacitance Change	$\pm 10\%$ of initial measured value.	
		$\tan \delta$	\leq The value of item 3.	
		Appearance	No noticeable abnormal change shall occur.	



No	Item	Characteristics		Outline of test method
8	Adhesion	Appearance: Without mechanical damage such as breaks after test.		Push direction: Side Force:5.0N Holding time:10±0.5s
9	Damp heat, Steady state	Leakage Current	≤The value of item 1.	Test temperature:60±2°C Relative humidity:90%R.H. Test time:500 ⁺²⁴ / ₋₀ h
		Capacitance Change	+70%,-20% (2V,2.5V) +60%,-20% (4V) +50%,-20% (6.3V) +40%,-20% (8V to 16V) of initial measured value.	
		tanδ	≤200% of item 3.	
		Appearance	No noticeable abnormal change shall occur.	
10	Damp heat, Steady state (Applied voltage)	Leakage Current	≤The value of item 1.	Test temperature:60±2°C Relative humidity:90%R.H. Applied voltage: Rated voltage Test time:500 ⁺²⁴ / ₋₀ h
		Capacitance Change	+70%,-20% (2V,2.5V) +60%,-20% (4V) +50%,-20% (6.3V) +40%,-20% (8V to 16V) of initial measured value.	
		tanδ	≤200% of item 3.	
		Appearance	No noticeable abnormal change shall occur.	
11	Endurance	Leakage Current	≤The value of item 1.	Test temperature:105±2°C Applied voltage: Rated voltage Test time:1000 ⁺⁴⁸ / ₋₀ h
		Capacitance Change	±10% of initial measured value.	
		tanδ	≤The value of item 3.	In case of H series , Test temperature:125±2°C Applied voltage: Rated voltage x0.75 Test time:1000 ⁺⁴⁸ / ₋₀ h
		Appearance	No noticeable abnormal change shall occur.	
12	Shelf life	Leakage Current	≤The value of item 1.	Test temperature:105±2°C Test time:500 ⁺²⁴ / ₋₀ h
		Capacitance Change	±10% of initial measured value.	
		tanδ	≤The value of item 3.	In case of H series , Test temperature:125±2°C Test time:500 ⁺²⁴ / ₋₀ h
		Appearance	No noticeable abnormal change shall occur.	

Product Specifications **4**



No	Item	Characteristics		Outline of test method	
13	Characteristics at high and low temperature	Step	Characteristics	Expose the capacitor at each temperature in following order and measure characteristics in step 2, 4 and 5 as described on the left. Step conditions See "Step Table "	
		2	Capacitance		±15% of the value in step 1.
			ESR		≤115% times of the value of item 4.
		4	Capacitance		20% of the value in step 1.
		5	Leakage current		≤The value of item 1.
Capacitance	±5% of the value in step 1.				
	tanδ	The value of item 3.			
14	Surge	Leakage current	≤The value of item 1.	Test temperature: 15 to 35°C Series resistor: 1000Ω Test voltage: Surge voltage See "Surge-voltage Table " Applied voltage: 1000 cycles of 30±5s "ON" and 5 min 30s "OFF"	
		Capacitance change	±10% of initial measured value.		
		tanδ	The value of item 3.		
		Appearance	No noticeable abnormal change shall occur.		
15	Vibration	Appearance: No noticeable abnormal change shall occur.	Frequency: 10 to 2000 to 10 Hz (One cycle per 20 min) Total amplitude: 1.5mm Direction and duration of vibration: 2 hours for each of three right-angle directions, total 6 hours. Mounting method: The capacitor must be soldered in place.		
		Capacitance: During test, measured value to be stabilized. (When measured several times within 30 min, before completion of test.)			

Step Table

Step	Standard S series	H series
	Temperature	Temperature
1	20±2°C	20±2°C
2	-40±2°C	-40±2°C
3	20±2°C	20±2°C
4	105±2°C	125±2°C
5	20±2°C	20±2°C

Surge-voltage Table

Rated voltage (V)	2	2.5	4	6.3	8	12.5	16
Surge voltage (V)	2.5	3.1	5	8	10	16	20



Application Guidelines

Specialty Polymer Aluminum Electrolytic Capacitor should be used in compliance with the following guidelines.

1. Circuit Design

1.1 Prohibited Circuits for use

Do not use the capacitors in the following circuits.

- (1) Time-constant circuits
- (2) Coupling circuits
- (3) 2 or more capacitors connected serially
- (4) Circuits which are greatly affected by leakage current

1.2 Voltage

The application of over-voltage and reverse voltage described below can cause increases in leakage current and short circuits.

Applied voltage, refers to the voltage value including the peak value of the transient instantaneous voltage and the peak value of ripple voltage, not just steady state line voltage.

Design your circuit so that the peak voltage does not exceed the specified voltage.

[Over-voltage]

Do not apply voltage in excess of the rated voltage.

Use at 85% or less of the rated voltage for H-Series 125°C rating, 15% voltage derating is required.

[Derating]

Voltage derating may be required depending on the operating temperature over 105 °C (25% voltage derating at 125 °C).

1.3 Ripple Current

Use the capacitors within the stipulated, permitted ripple current.

When excessive ripple current is applied to the capacitor, it causes increases in leakage current and short circuits due to self-heating.

Even when using the capacitor under the permissible ripple current, reverse voltage may occur if the DC bias voltage is low.

1.4 Leakage Current

There is a risk of leakage current characteristics increasing even if the following usage conditions or environments are within the stipulated range.

However, even if leakage current increases once, it has the characteristic that leakage current becomes small in most cases after voltage is applied due to its self-correction mechanism.

- (1) After re-flow
- (2) Shelf conditions such as (1) high temperature with no load, (2) high temperature high humidity with no load and (3) sudden temperature changes.

1.5 Failure Rate

The majority of failure modes are short circuits or an increase in leakage current.

The main factors of failure are mechanical stress, heat stress, and electrical stress due to re-flow heat and heat from the operating environment temperature.

Even within the stipulated limits, it is possible to lower the failure rate by reducing usage conditions such as temperature and voltage. Please be sure to have ample safety margins in your design.

[Expected Failure Rate]

- (1) Data based on our reliability tests: 46FIT or less (Based on applied rated voltage at 105°C)
- (2) Market failure rate : 0.13FIT or less (Based on c=0, Reliability standard : 60%)

Always consider safety when designing equipment and circuits. Plan for worst case failure modes such as short circuits and open circuits which might occur during use.

- (1) Provide protection circuits and protection devices to allow safe failure modes.
- (2) Design redundant or secondary circuits where possible to assure continued operation in case of main circuit failure.

Application Guidelines 17

2. Usage & Storage Conditions and Soldering

2.1 Storage

Products should be stored in a moisture proof environment.

Storage conditions before and after opening the moisture proof packaging should be maintained as follows.

(If these conditions are exceeded, the package may absorb moisture and there is a risk of damage to the exterior due to heat stress during mounting.)

[Environment of storage]

Temperature: 5°C to 30°C without direct sunlight

Humidity : Less than 70%RH

Maximum storage term and condition before opening the package:

2 years after manufacture

(JEDEC J-STD-020B MSL: Level 2)

Maximum storage term and condition after opening the package:

Less than 14 days*

(JEDEC J-STD-0208B MSL: Level 3)

* Series FD, H, and CD(12.5V & 16V) : 7 days or less

All products should be used within the storage term after opening the package.

After the storage limit, baking treatment is necessary to be able to use the products.

The storage conditions after baking are the same as those after opening the package.

[Baking conditions]

Temperature: 50 ± 2°C

Time: 100 to 200 hours

(Do not perform more than twice.)



2.2 Temperature

Use at or under the rated (guaranteed) temperature. Operation at temperatures exceeding specifications causes large changes in the capacitors electrical properties, and deterioration that can potentially lead to failure.

When calculating the operating temperature of the capacitor, be sure to include not only the ambient temperature and internal temperature of the unit, but also radiation from heat generating elements inside the equipment (power transistors, resistors, etc.), and self-heating due to ripple current.

2.3 Capacitor Mounting

(1) Land Size

Refer to the land size table for appropriate design dimensions. Circuit board design requires examination of the most suitable dimensions taking conditions such as circuit board, parts and re-flow into consideration. These products are designed specifically for re-flow soldering.

Consult with our factory before performing mounting processes other than re-flow soldering.

(2) Heat stress of re-flow, etc.

Specified re-flow conditions must be strictly observed. Soldering under other conditions can cause short circuits and increases in ESR.

(3) Repair and modification by soldering iron

When using a soldering iron, set the tip temperature to no more than 350°C, and work in as short a time as possible under 10 seconds. While soldering, do not apply strong force to the capacitor.

(4) Mechanical stress

Do not apply excessive force to the capacitor, since this can damage the electrodes and adversely affect the capacitor's mountability. It can also cause an increase of leakage current, separation of the lead wire and element, and damage to the capacitor body, all of which can adversely affect the electrical performance of the capacitor.

2.4 Transportation

Take sufficient care during handling because excessive vibration, and/or shock can cause the reliability of the capacitor to decrease.

2.5 Circuit Board Cleaning

Products should be cleaned after soldering in accordance with the following conditions.

Temperature: Less than 60°C

Time: Within 5 minutes (Ultrasound OK)

Be sure to sufficiently wash and dry (20 min. at 100°C) the board afterward.

[Recommended cleaning solvents]

Pine Alpha ST-100S, Sunelec B-12, DK beclear CW-5790, Aqua Cleaner 210SEP, Cold Cleaner P3-375, Telpen Cleaner EC-7R, Clean-thru 750H, Clean-thru 750L, Clean-thru710M, Techno Cleaner 219, Techno Care FRW-17, Techno Care FRW-1, Techno care FRV-1, AXREL32

Note 1 : Consult our factory when performing processes with cleaning solvents other than those listed above.

2 : The use of ozone depleting cleaning agents are not recommended in the interest of protecting the environment.

3. Others

3.1 Precautions for using capacitors

Capacitors are not to be used in the following environments.

- (1) Environments where the capacitor is subject to direct contact with water, salt water or oil.
- (2) Environments where capacitors are exposed to direct sunlight.
- (3) High temperature, or humid environments where condensation can form on the surface of the capacitor.
- (4) Environments where the capacitor is in contact with chemically active gases.
- (5) Acidic or alkaline environments.
- (6) Environments subject to high-frequency induction.
- (7) Environments subject to excessive vibration and/or shock.

3.2 Emergency Procedures

If the capacitor is overheated, the resin case may emit smoke. If this occurs, immediately switch off the equipment's main power supply to stop operation. Keep your face and hands away from the capacitor, since the temperature may be high enough to cause the capacitor to ignite and burn.

3.3 Capacitor Disposal

Since capacitors are composed of various metals and resins, treat them as industrial waste when arranging for their disposal.

3.4 Using Capacitor for Applications which Can Affect Human Life

Consult with our factory before use in applications which can affect human life.

Don't use for control circuits which affect human life, such as medical equipment, airplanes, etc. without consent of our company.



Packaging Specifications

● Emboss taping (mm)

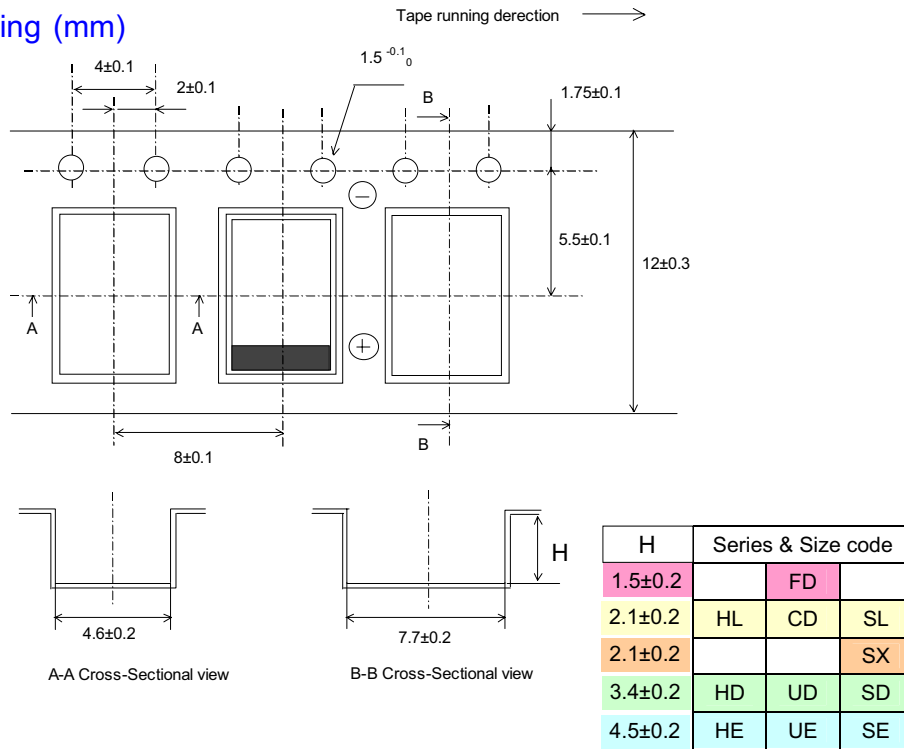

● Taping reel (mm)

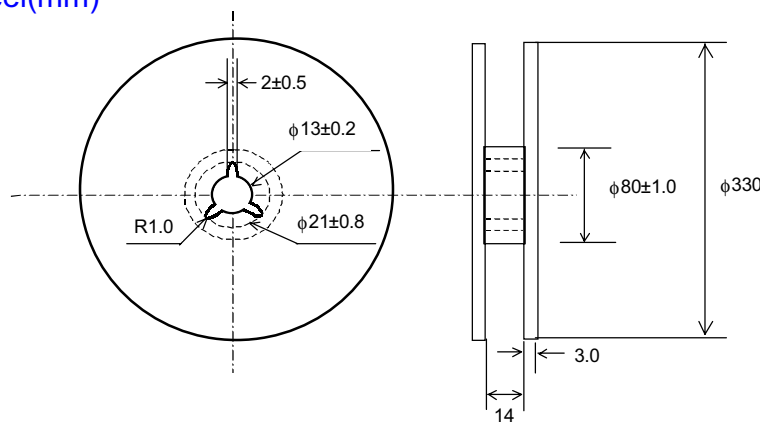

● Packaging Box Dimensions (mm)

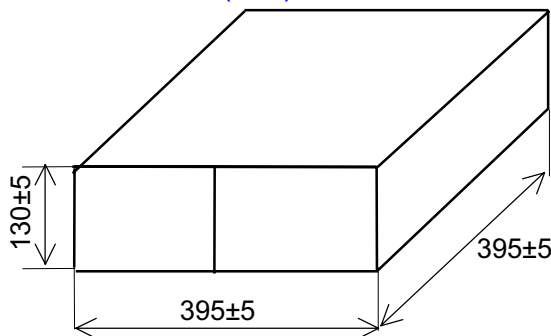

Packaging Specifications



Soldering Specifications

We recommend soldering be done according to the following maximum permissible reflow soldering temperature profile.

Reflow soldering

(This is a method to heat parts and the substrate by hot air or infrared furnace.)

*Do not perform reflow soldering more than twice

Please be sure to perform the second reflow soldering within 5days.

(Please refer to item 5 of the Application Guidelines for the proper storing conditions prior to the second reflow)

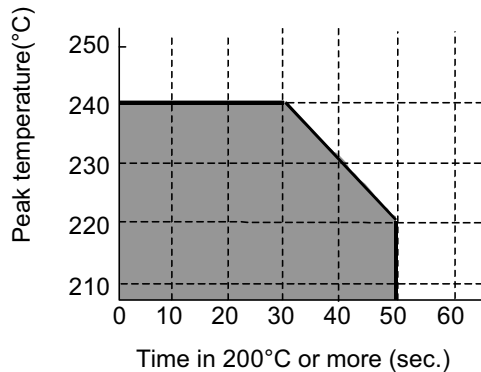
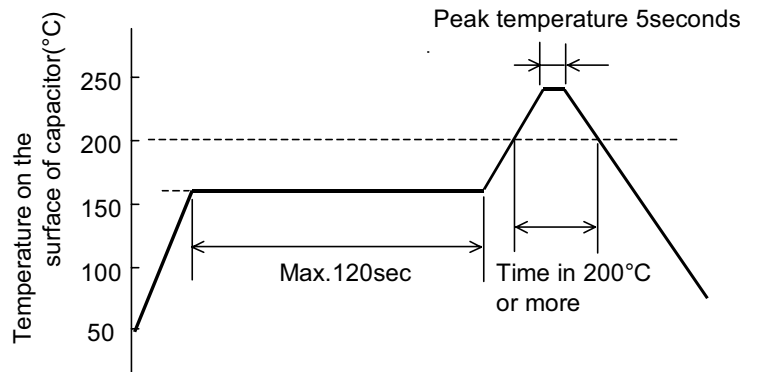

Reference Land-pattern

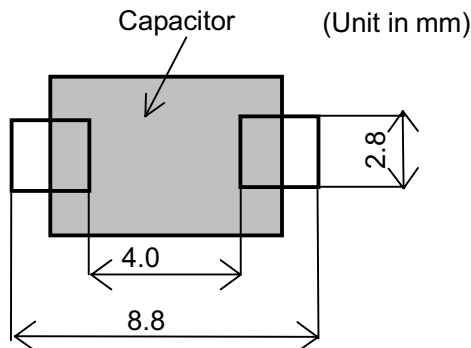

Same land pattern design as a Tantalum electrolytic capacitor 7.3 x 4.3 mm product



Special Capabilities

Excellent noise absorption

Noise absorption of the SP-Cap compared with other types of capacitors is shown below.

Test Circuit

Input voltage: 8Vp-p
Frequency : 1MHz

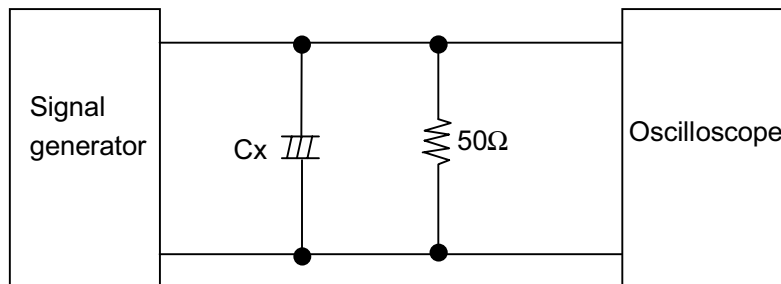

Results of comparison obtained when the noise absorption levels are set identical to each other.

Input waveform (1MHz)	Output waveform		
	Aluminum capacitor	Tantalum capacitor	SP-Cap
	1000 μ F \times 4 	100 μ F \times 3 	47 μ F \times 1
8V p-p	54mV p-p	40mV p-p	30mV p-p

The SP-Cap is excellent for noise absorption and capable of reducing the number of parts, thus reducing overall circuit size.





Excellent ripple voltage reduction

The voltage smoothing capability of the SP-Cap on the switching power supply output side compared with that of other types of capacitors is shown below.

Test Circuit

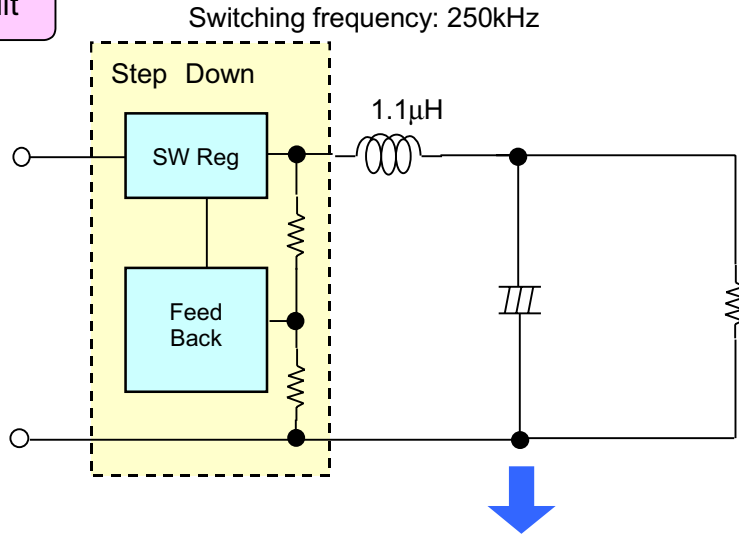

Ripple Voltage Reduction Comparison.
All capacitors valued identically at 220µF.

SP-Cap	Polymer tantalum	Low ESR tantalum
2.5V 220µF	2.5V 220µF	6.3V 220µF
ESR=10mΩ at 100kHz	ESR=25mΩ at 100kHz	ESR=50mΩ at 100kHz
Ripple voltage:50mVp-p	Ripple voltage:125mVp-p	Ripple voltage:265mVp-p

To reduce ripple voltage, an SP-Cap with a very low ESR is more suitable. For the same capacitance, an SP-Cap allows the ripple voltage to be reduced to approximately 1/3 that of a polymer tantalum capacitor and approximately 1/5 that of a low ESR tantalum capacitor.

Special Capabilities



Excellent transient response

The transient response of the SP-Cap as the load varies in a high speed condition compared with that of other types of capacitors is shown below.

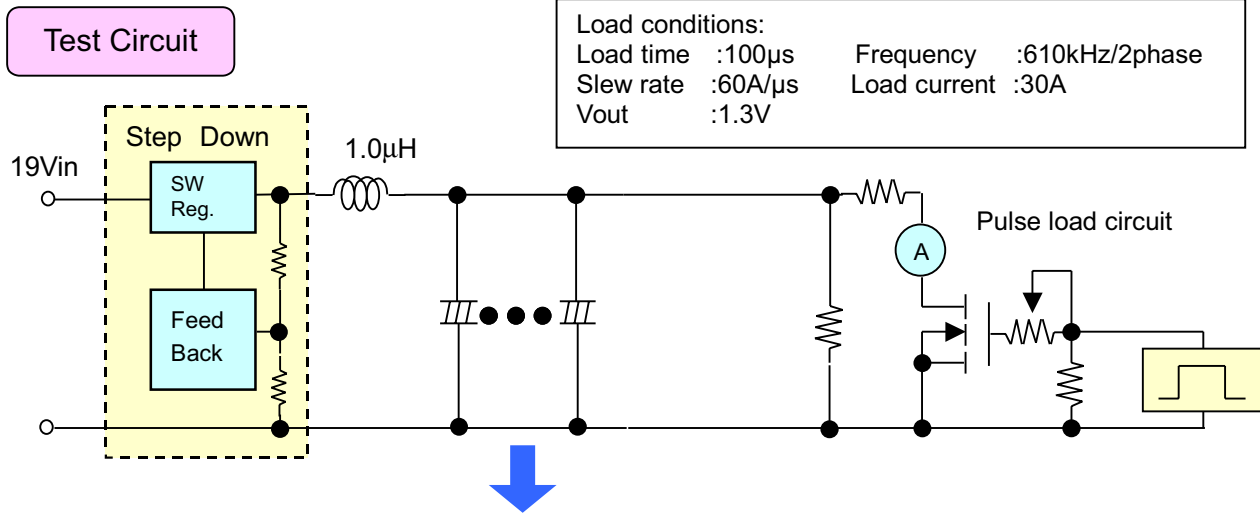

Results of comparisons obtained when variable output voltages are identical to each other.

Specialty Polymer Aluminum (SP-Cap)		Specialty Polymer Tantalum	
2V 270 μ F x5 pcs	2V 220 μ F x8 pcs	4V 470 μ F x5 pcs	2.5V 330 μ F x8 pcs
Total Cap. =1350 μ F at 120Hz	Total Cap. =1760 μ F at 120Hz	Total Cap. =2350 μ F at 120Hz	Total Cap. =2640 μ F at 120Hz
ESR=3m Ω max.at 100kHz	ESR=1.9m Ω max.at 100kHz	ESR=3m Ω max.at 100kHz	ESR=1.9m Ω max.at 100kHz

Because the SP-Cap provides a very low ESR, the same transient response can be obtained with less capacitance. To obtain the same transient response with polymer tantalum, higher capacitance is required than with the polymer aluminum.

Special Capabilities



Transient Response Simulation

Application Example (CPU)

Trend of CPU (Central Processing Unit) used in personal computers

- CPUs continue to follow Moore's Law of doubling operating frequency every 18 months. Today' CPUs are operating above Ghz frequencies. The Ghz-plus CPUs are characterized by increased power, high operating DC current and current slew rate requirements, and a challenging voltage margin.

- To reduce energy consumption:
 - CPU stop clock operation is used.
 - CPU drive voltage is lowered.

- In order to reduce power consumption, a switching operation (ON and OFF) is repeated frequently by the CPU stop clock operation.

- A large voltage fluctuation occurs in the CPU drive power line.

- Load current when CPU is operated (ON) is increased.

- As the CPU computing and operational demand vary, the current demands for the CPU can change very rapidly and require current slew rates of hundreds of amps within a few micro seconds.

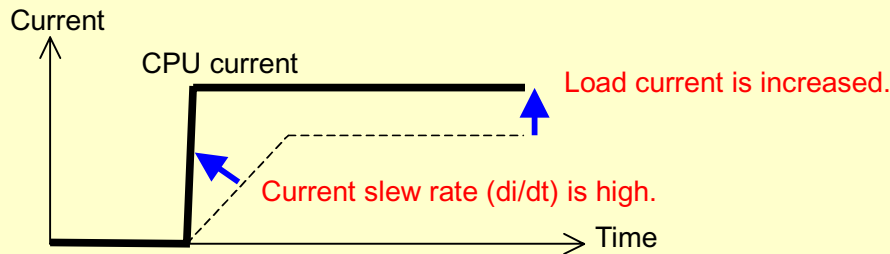

- Reduction in CPU drive voltage

- The allowable voltage fluctuation range for CPU operation becomes tighter.

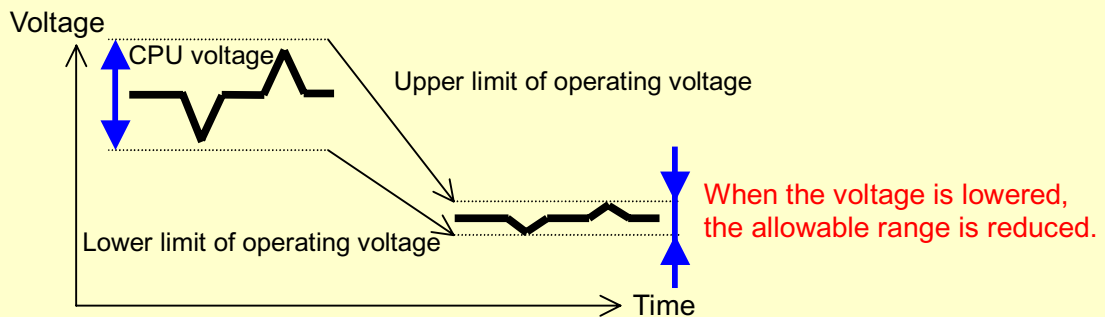

Today's CPUs can require current slew rates of hundreds of amps per micro second. The resulting current surge can create unacceptable spikes in the voltage which must be suppressed within the operating voltage margin before any damage is done to the CPU.



The performance requirements for bulk capacitors have increased due to the increase in the transient response and power requirements of the CPU.

- A capacitor functions as a buffer to supply an instantaneous current at a stable voltage.

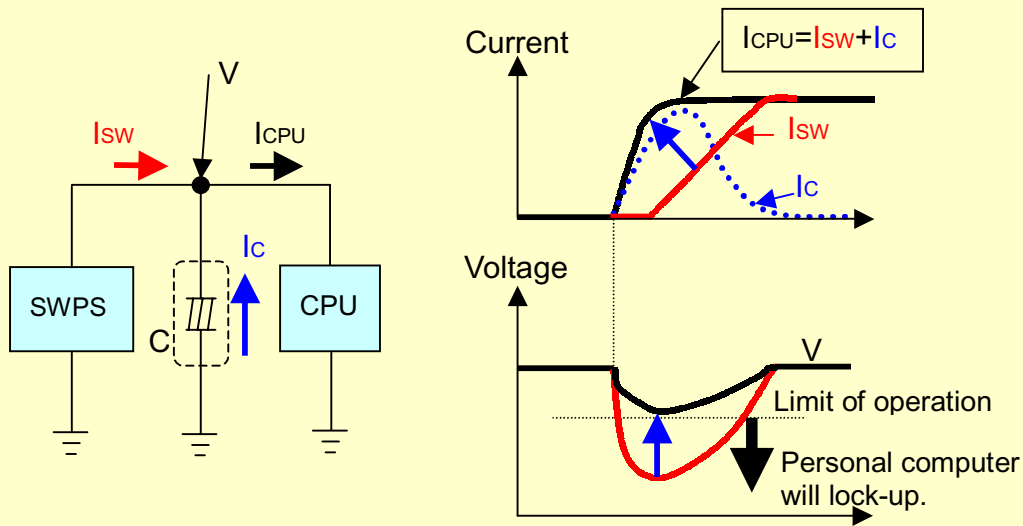

This transient response simulation presents the optimum idea of capacitor pick up for power supply design.

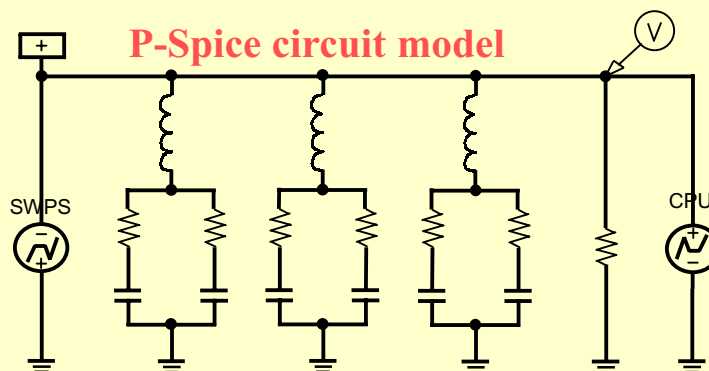



Simulation method

For the simulation of CPU transient response characteristics, a capacitor-equivalent circuit model must be created and the circuit conditions must be set up.

In order to simulate the transient response characteristics of a capacitor, an equivalent circuit model is needed that is capable of indicating the variation in ESR* and the reduction in capacitance in the high frequency range.

* ESR: Equivalent Series Resistance

Example of a reproduction of frequency characteristics using an equivalent circuit model

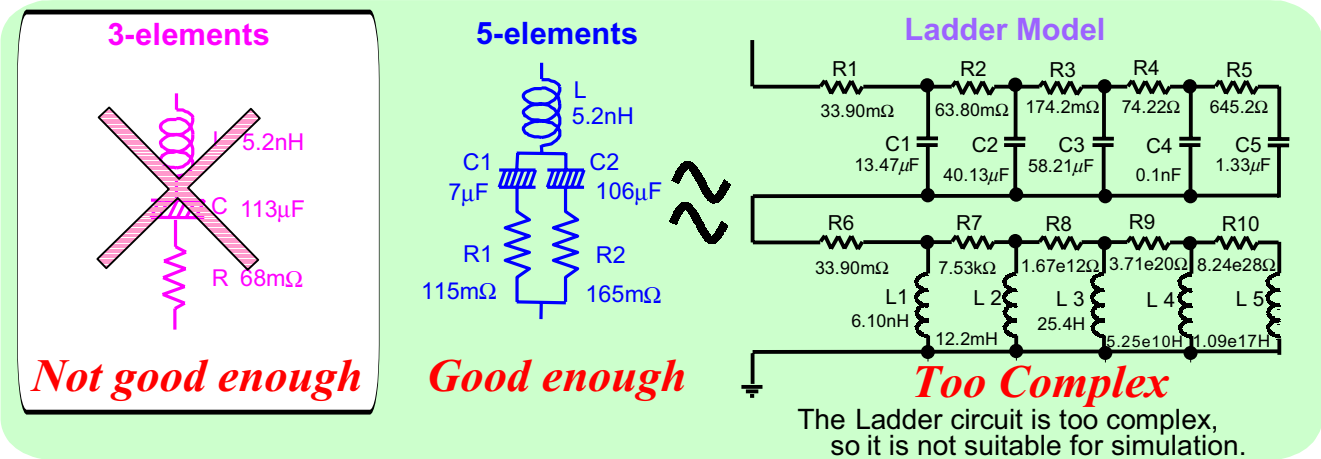

10 Transient Response Simulation

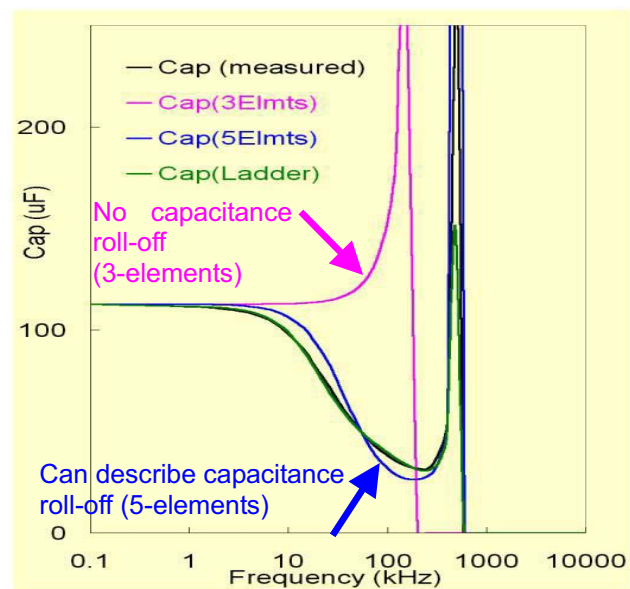
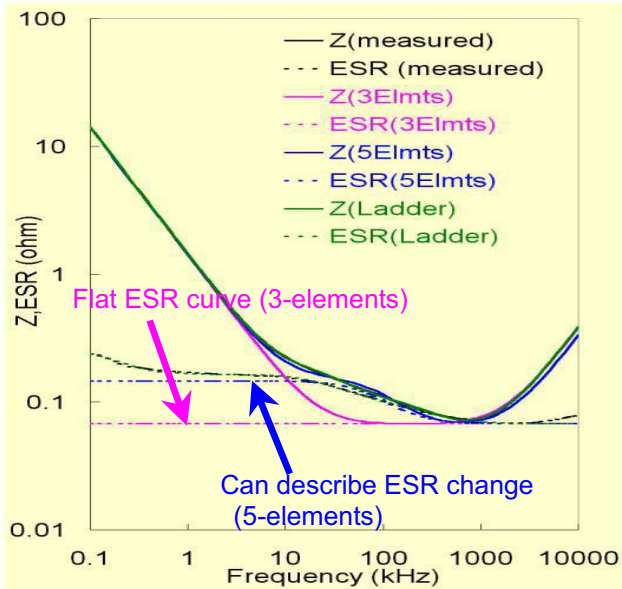



Setting of circuit conditions

Circuit condition: Put capacitors in parallel between power supply and CPU as described below.

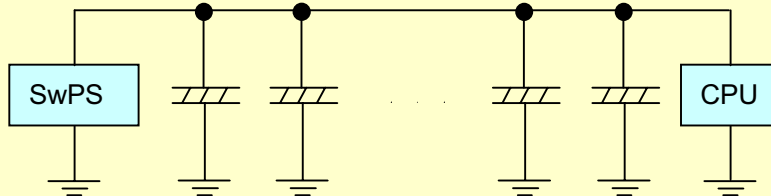

The number of capacitors is calculated using a P Spice circuit simulator under the following conditions of the application.

- Operating current and ramp up time (di/dt) of CPU conditions.
- Operating voltage and range of CPU.
- Switching frequency and phase of SW power supply.
- Inductance of PCC (Power Choke Coil) of SW power supply.
- Min. input voltage of SW power supply.

When CPU voltage varies and current is managed, CPU performance is optimized.

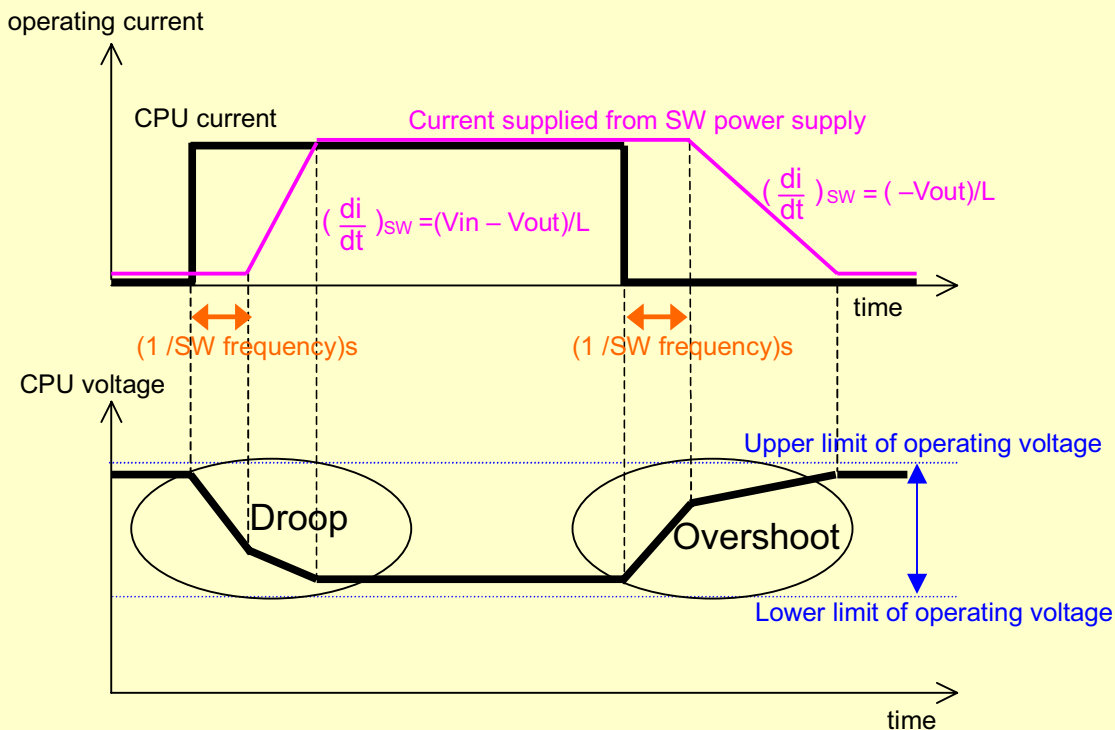

It takes time for the SW power supply to respond to the CPU when it turns on
 → Capacitors are necessary to smoothly transfer the voltage from the CPU start-up.



Estimation of capacitance-frequency characteristics using the Ladder model

LCR meters are unable to measure capacitance at the resonance point frequencies and above. Using an LCR 20-element ladder model, we propose estimating the behavior of the measured capacitance-frequency characteristics around the point of resonance.

Ref. Low ESR Tantalum (D-size 10V100uF)

Creation of the capacitance-frequency characteristics excluding the effects of inductance

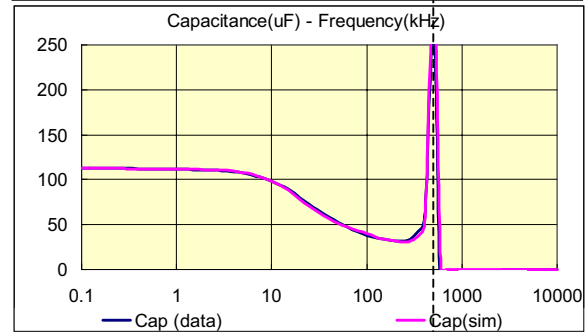
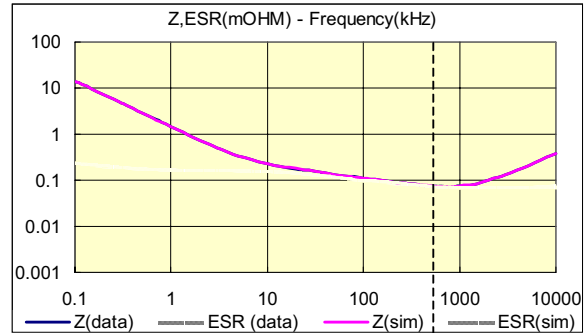
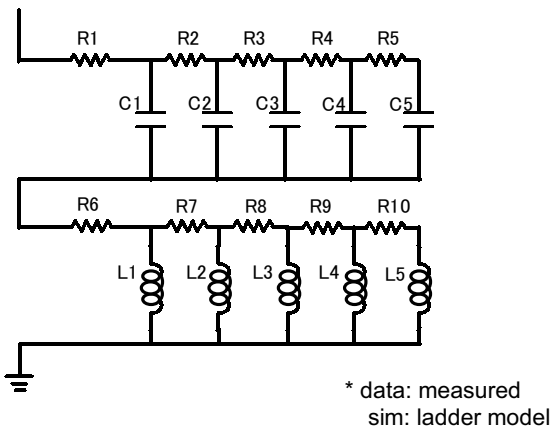

Resonance Point

Removal of the R-L circuit

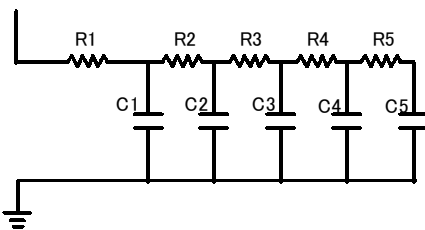

Estimation of capacitance characteristics at high frequency

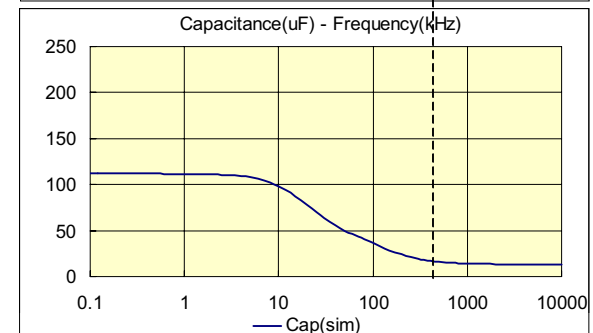
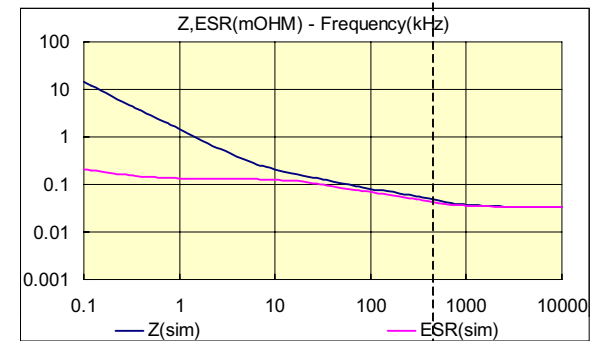

10 Transient Response Simulation



Safety and Reliability

Safety

The specialty polymer aluminum electrolytic capacitor (SP-Cap) is more difficult to "smoke" and ignite than a tantalum capacitor. The capacitor will not "red-heat" or ignite even if a 10A current is applied; even in the case of a short circuit.

Safety test

A constant current was passed through a short-circuited capacitor, and the capacitor was observed to check for smoking and ignition.

- Test conditions

To short-circuit, an overvoltage of 30 V DC was applied to a capacitor at room temperature, and then a constant current was applied to the capacitor for two minutes.

- Test results

The presence or absence of smoke and the number of capacitors that red-heated and ignited are shown below (unit: piece)

Specialty polymer aluminum electrolytic capacitor 6.3V 33 μ F (7.3 x 4.3 x 1.8)

Current (A)	Test times	Not smoked	Smoked	Red-heated and ignited
1	50	50	0	0
3	50	50	0	0
5	50	35	15	0
7	50	8	42	0
10	50	2	48	0

In the conditions shown above, red-heating and ignition were not induced.

The smoke emitted in the tests above was analyzed and harmful substances were not detected. (Detail: carbon dioxide <0.34mg, carbon monoxide <0.53mg, methane gas < 0.19mg/piece)

Tantalum electrolytic capacitor 6.3V150 μ F (7.3 x 4.3 x 2.8)

Current (A)	Test times	Not smoked	Smoked	Red-heated and ignited
1	50	50	0	0
2	50	25	25	0
3	50	8	8	34
4	50	0	0	50
5	50	0	0	50

*These test data are simply the results obtained from the reference tests and actual data may vary in actual applications.



The Specialty Polymer Capacitor is difficult to "smoke" and ignite

It is because:

- Aluminum is more difficult to burn than tantalum.
- Specialty polymer emits less oxygen than manganese dioxide.

Three elements of combustion

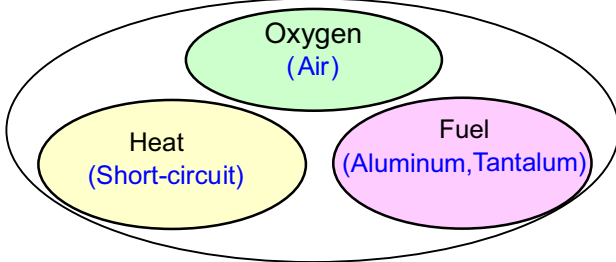

*For substances to burn, the three elements of combustion - heat, fuel, oxygen - are mandatory. If one of them is not present, burning will not occur.

Aluminum is more difficult to burn than tantalum.

	SP-Cap	Tantalum capacitor
Burning reaction	Al + O ₂	Ta + O ₂
Reaction start temperature	400°C ~ 600°C	250°C ~ 450°C
Activation energy	170kJ/mol	115kJ/mol

*Reaction becomes easier when the activation energy is lower.

→ Tantalum is more readily bound to oxygen (O₂), and burns at lower temperatures than aluminum.

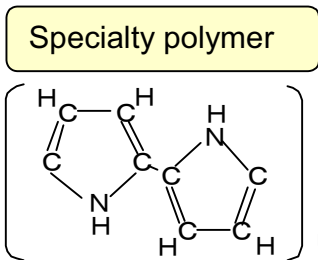

Manganese dioxide

MnO₂
 Example of the oxygen release reaction of manganese dioxide



→ Manganese dioxide releases oxygen to cause combustion.

Aluminum is more difficult to bind with oxygen than tantalum, and the specialty polymer will release less oxygen than manganese dioxide.

As a result, the SP-Cap is more difficult to "smoke" and ignite than a tantalum capacitor.



Reliability

The Specialty Polymer Aluminum Electrolytic Capacitor (SP-Cap) is more difficult to short-circuit than a tantalum capacitor.

Reliability test

Capacitors were tested for possible short-circuiting or burnout when voltage is applied in a high temperature environment.

- Test conditions
 - Test temperature : 85 to 145°C
 - Applied voltage : Rated voltage (W.V.) x (0.8 to 1.25)
 - Test time : 1,000 hours (without protective resistance)
 - Quantity of specimens: n = 20 for each condition

- Test results
 - The number of capacitors short-circuited or burned out are shown below.

Specialty polymer aluminum electrolytic capacitor 6.3V 47μF(7.3 x 4.3 x 1.8)

	0.8 x W.V.	W.V.	1.1 x W.V.	1.25 x W.V.
85°C	0	0	0	0
105°C	0	0	0	0
125°C	0	0	0	0
145°C	0	0	0	0

During the test, short-circuits did not occur under any of the conditions.

Tantalum capacitor 6.3V 220μF(7.3 x 4.3 x 2.8)

	0.8 x W.V.	W.V.	1.1 x W.V.	1.25 x W.V.
85°C	0	0	0	0
105°C	0	0	0	1
125°C	0	0	0	3
145°C	1	0	0	0

The short-circuited products were all burned out.

Normally, when the atmospheric temperature and voltage become higher, a product tends to short-circuit.

Predicted failure rate of SP-Cap*

- As a result of our reliability test, the following data were obtained.
 - Failure rate resulting from the temperature accelerated test: **46 FIT or less** (Predicted failure rate when the temperature is 105°C and the rated voltage is applied)
- Predicted market failure rate: **0.13 FIT or less** (c = 0, predicted failure rate when reliability level is 60%)

*This failure rate is for reference only. Actual failure rates may vary in actual applications.



The SP Cap is difficult to short-circuit

The specialty polymer is a substance (electrolyte) whose resistance rises with temperature.

When a defect occurs in the dielectric, the joule heat of the current flowing through the defect raises the resistance of the polymer to the point that it becomes self-insulating and shuts off the current flow.

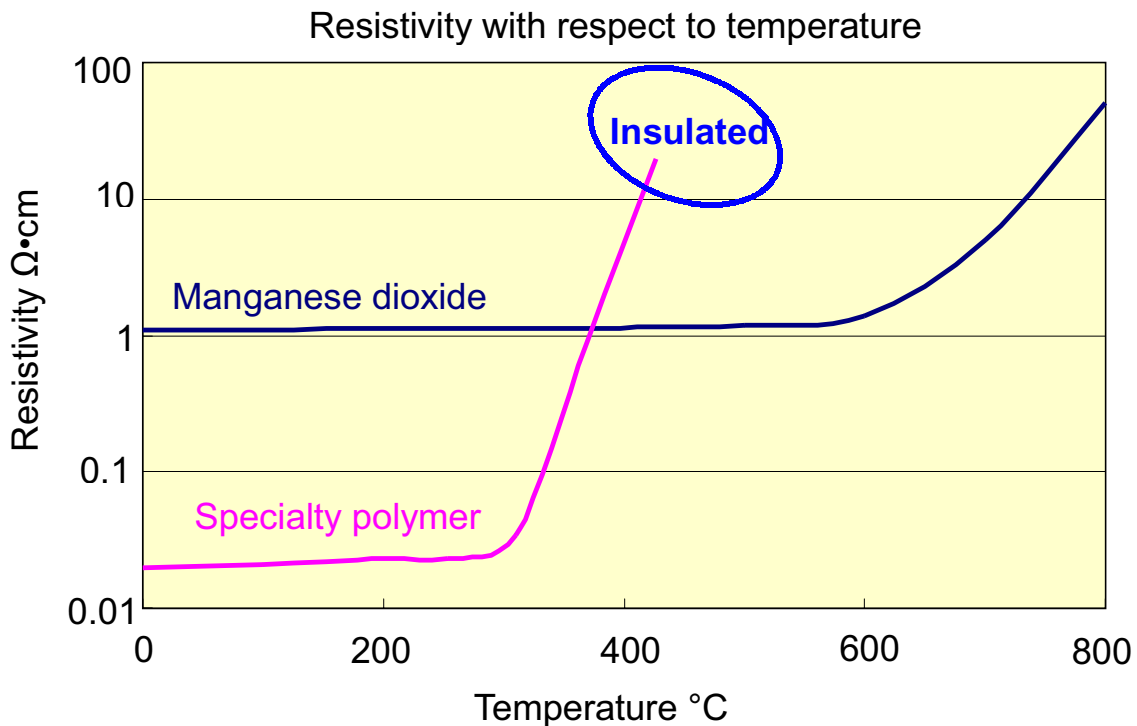

The specialty polymer insulates itself at a lower temperature compared with manganese dioxide. As a result, SP-AI is more difficult to short-circuit than a tantalum capacitor.



Data

Frequency characteristics*

■ CD Series (2W.V.)

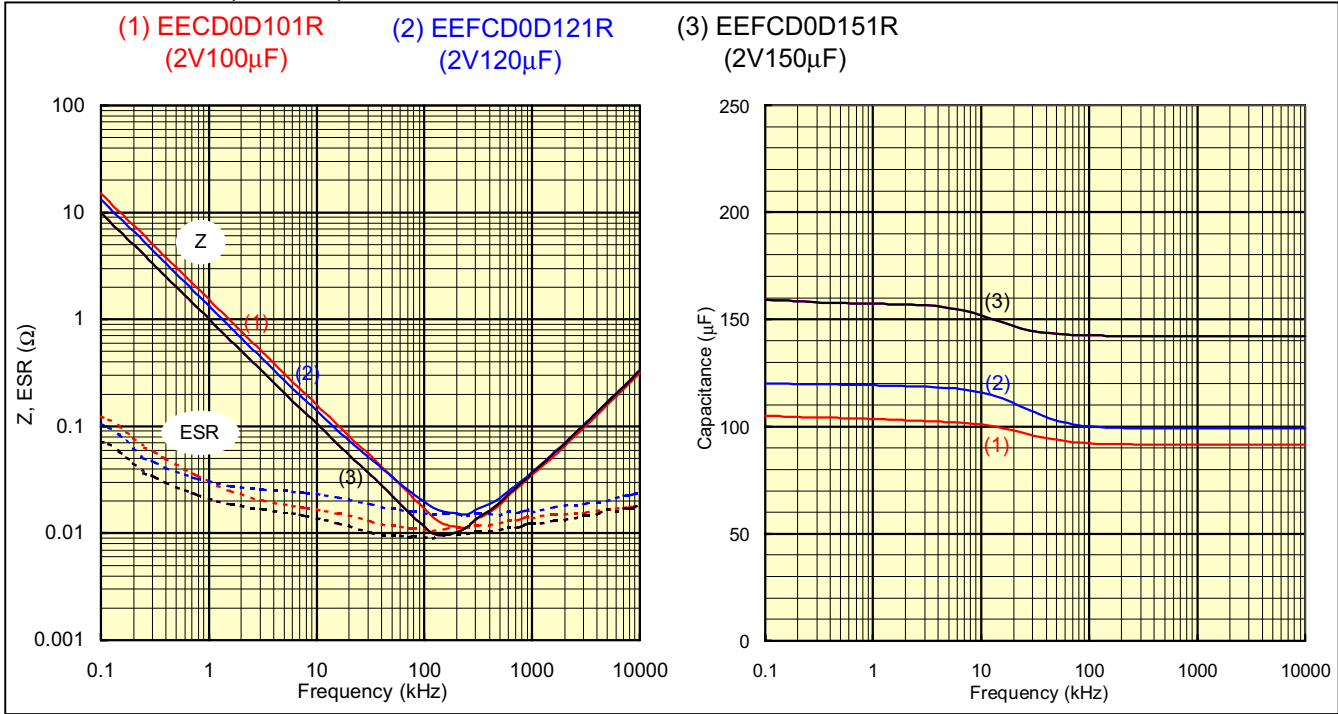

■ CD Series (2.5W.V.)

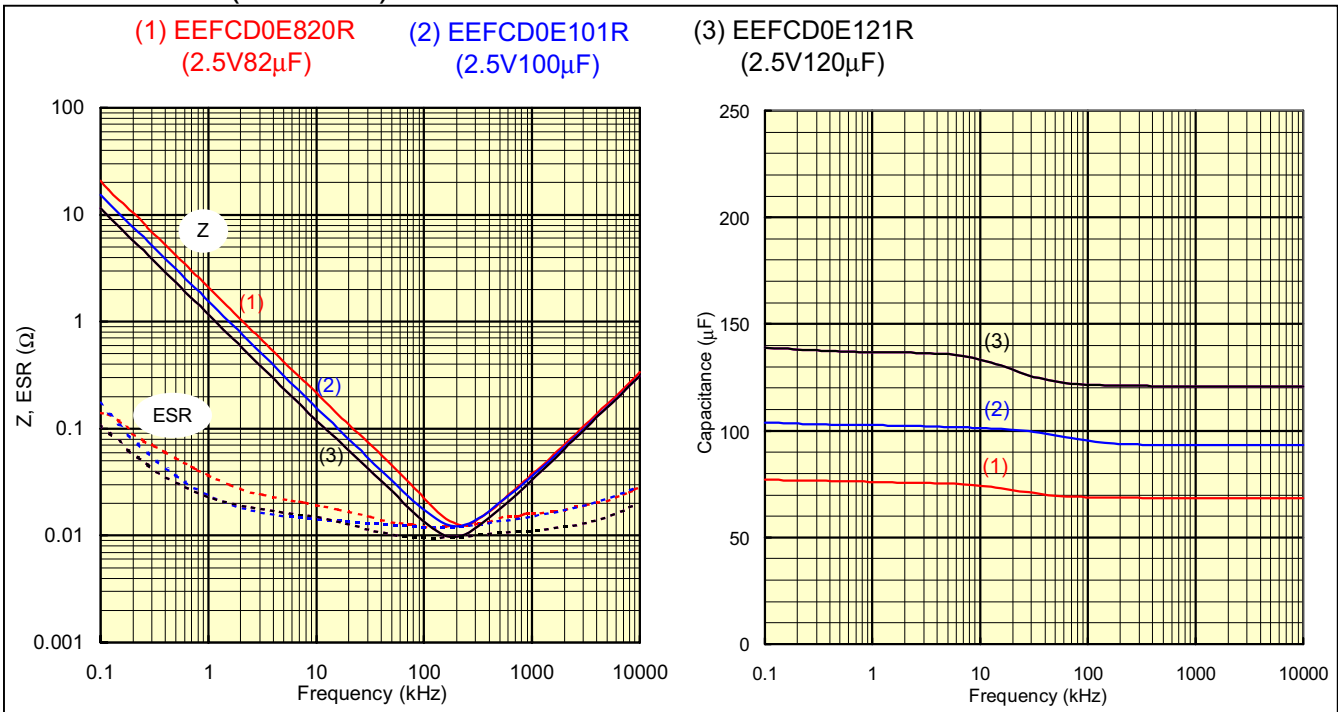

*Please refer to 'Estimation of capacitance-frequency characteristics using the Ladder model' on pg.28



Data

Frequency characteristics*

CD Series (4W.V.)

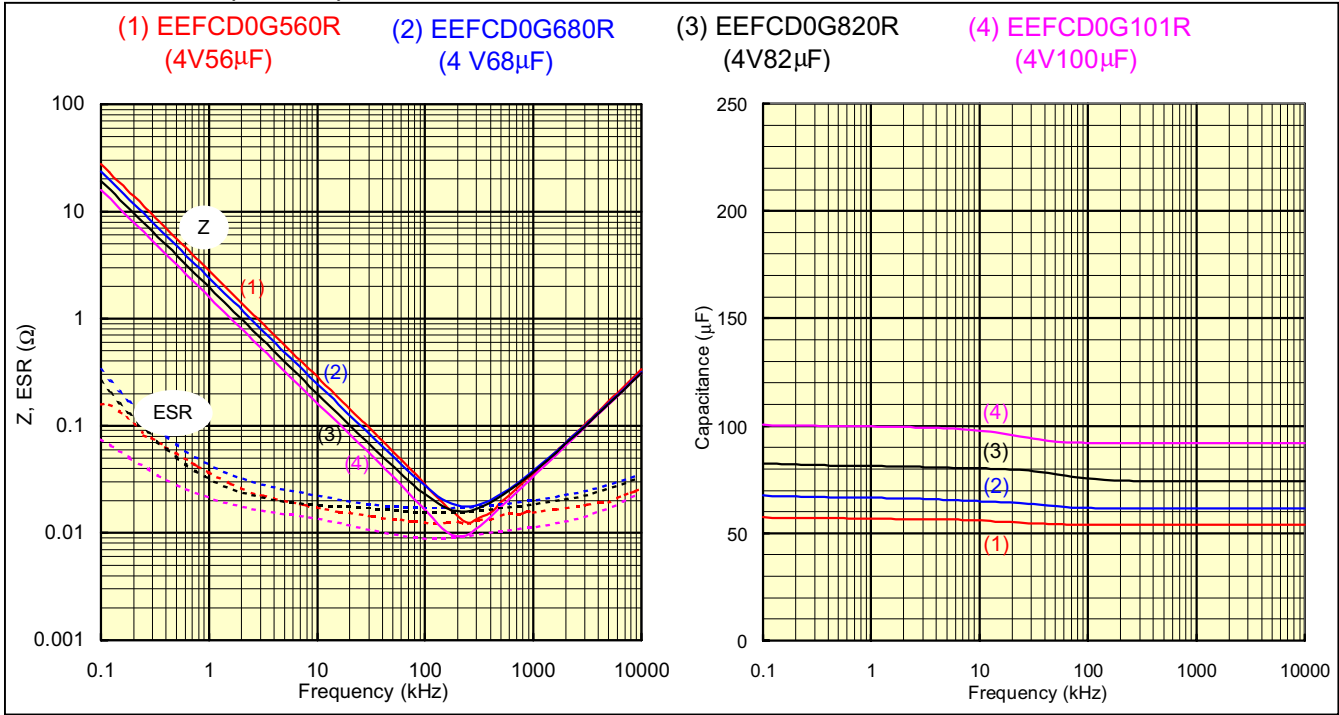

CD Series (6.3 W.V.)

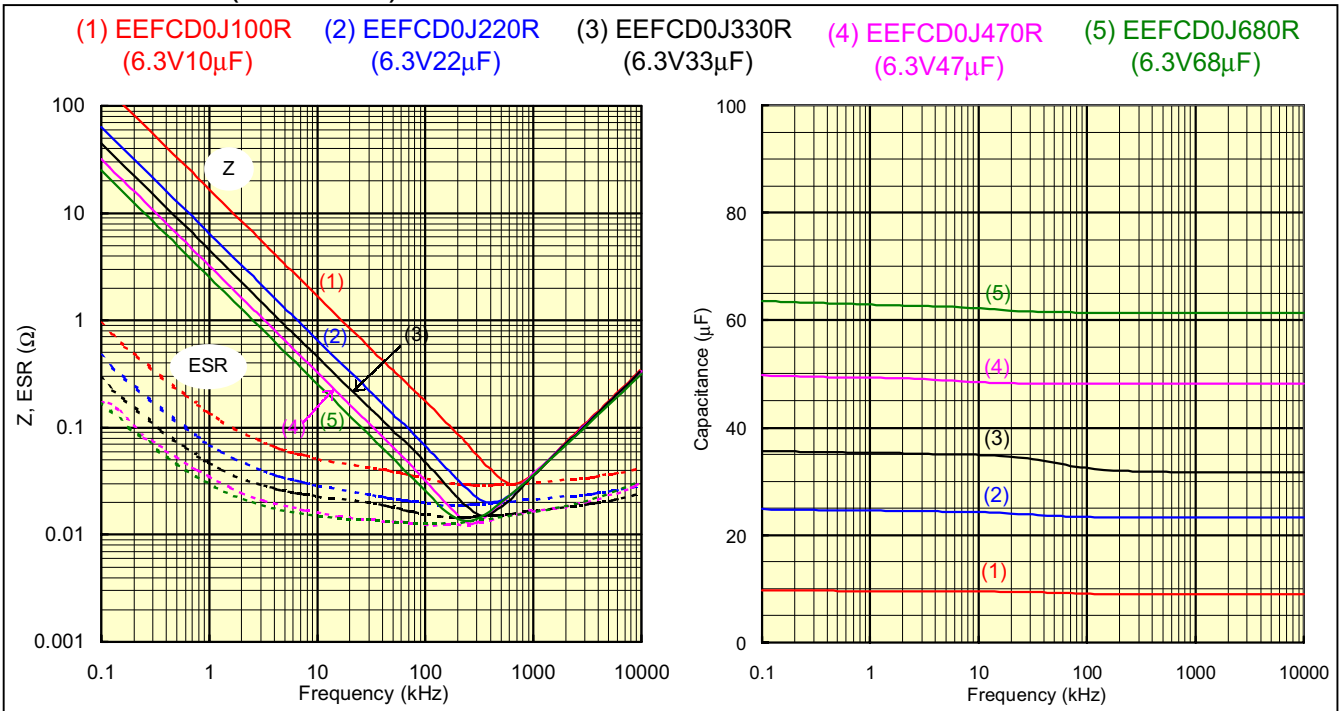

*Please refer to 'Estimation of capacitance-frequency characteristics using the Ladder model' on pg.28



Data

Frequency characteristics*

■ CD Series (8W.V.)

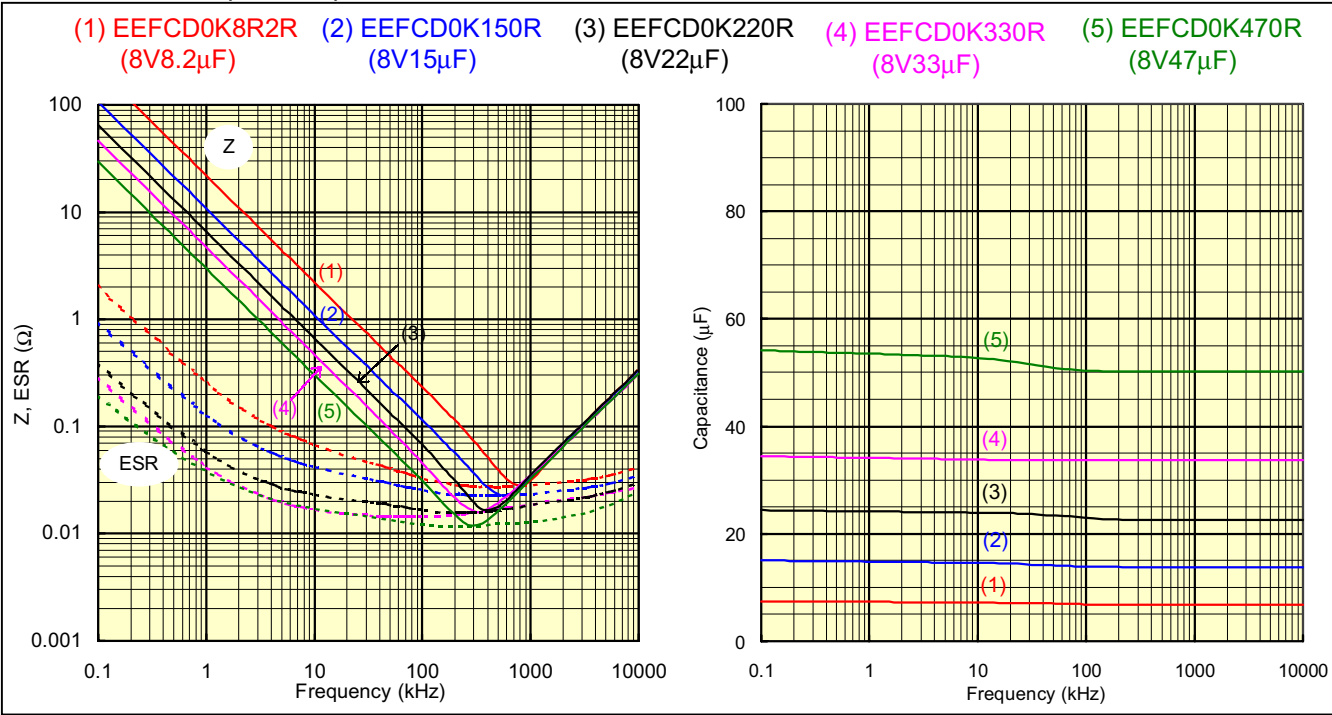

■ CD Series (12.5W.V.)

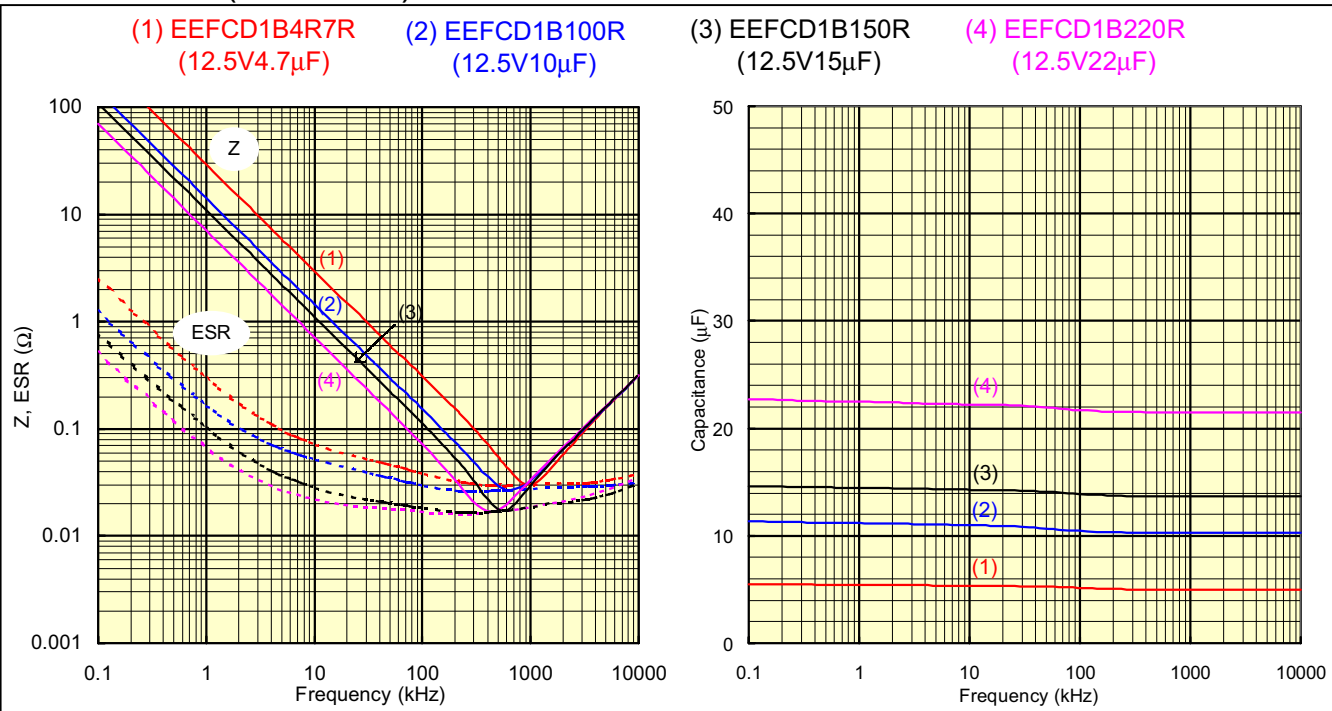

*Please refer to 'Estimation of capacitance-frequency characteristics using the Ladder model' on pg.28



Data

Frequency characteristics*

■ CD Series (16W.V.)

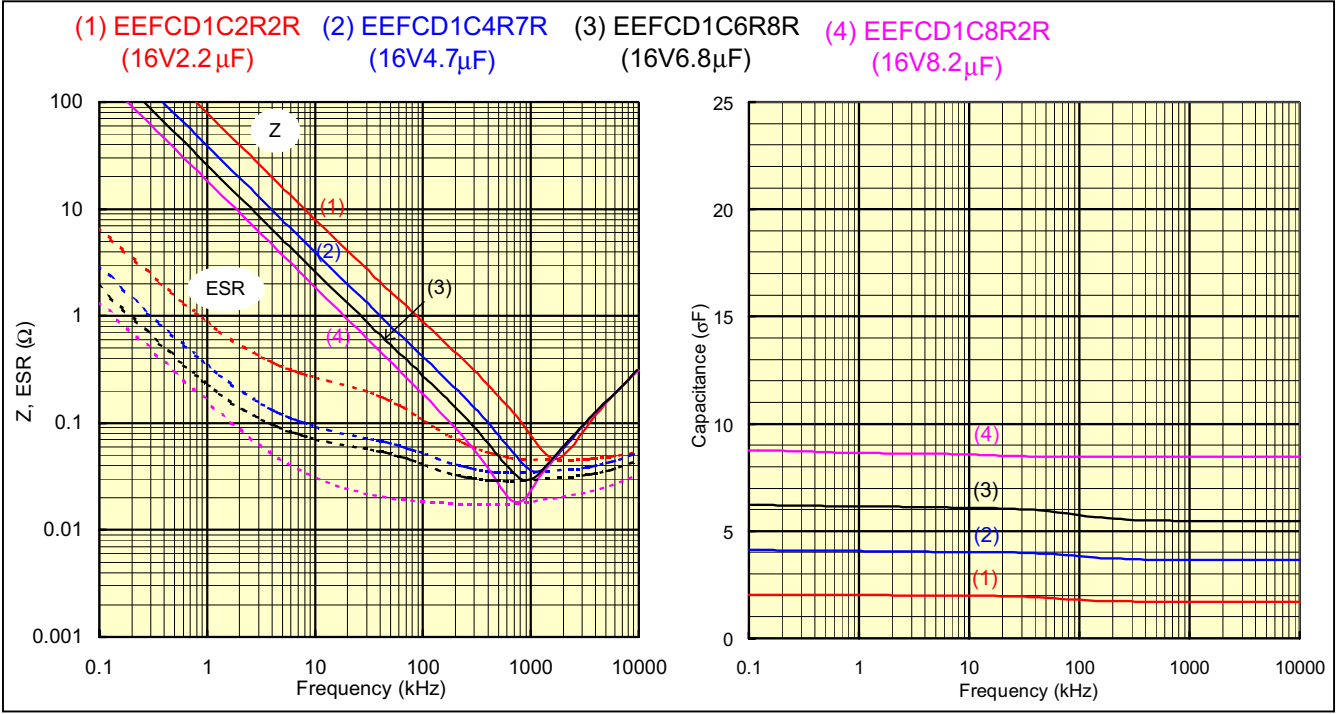

■ UD Series (2W.V.)

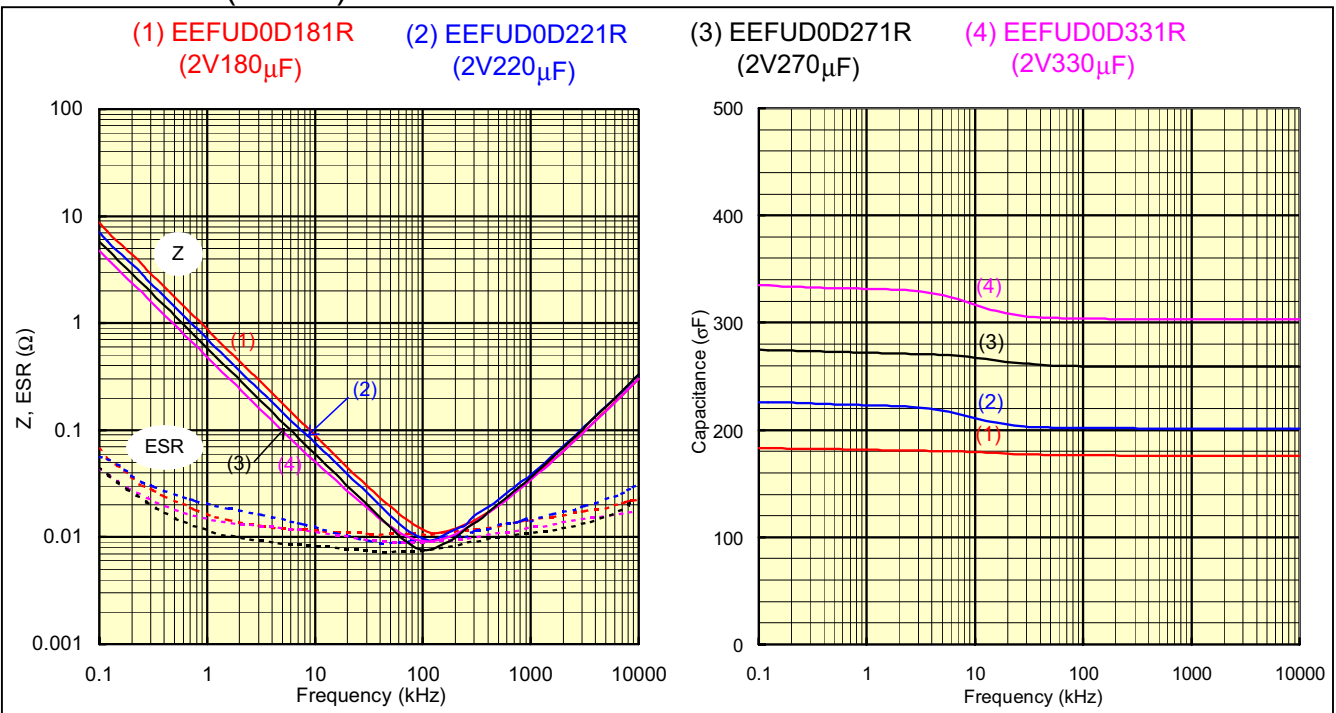

* Please refer to 'Estimation of capacitance-frequency characteristics using the Ladder model' on pg.28

12 Data



Data

Frequency characteristics*

UD Series (2.5W.V.)

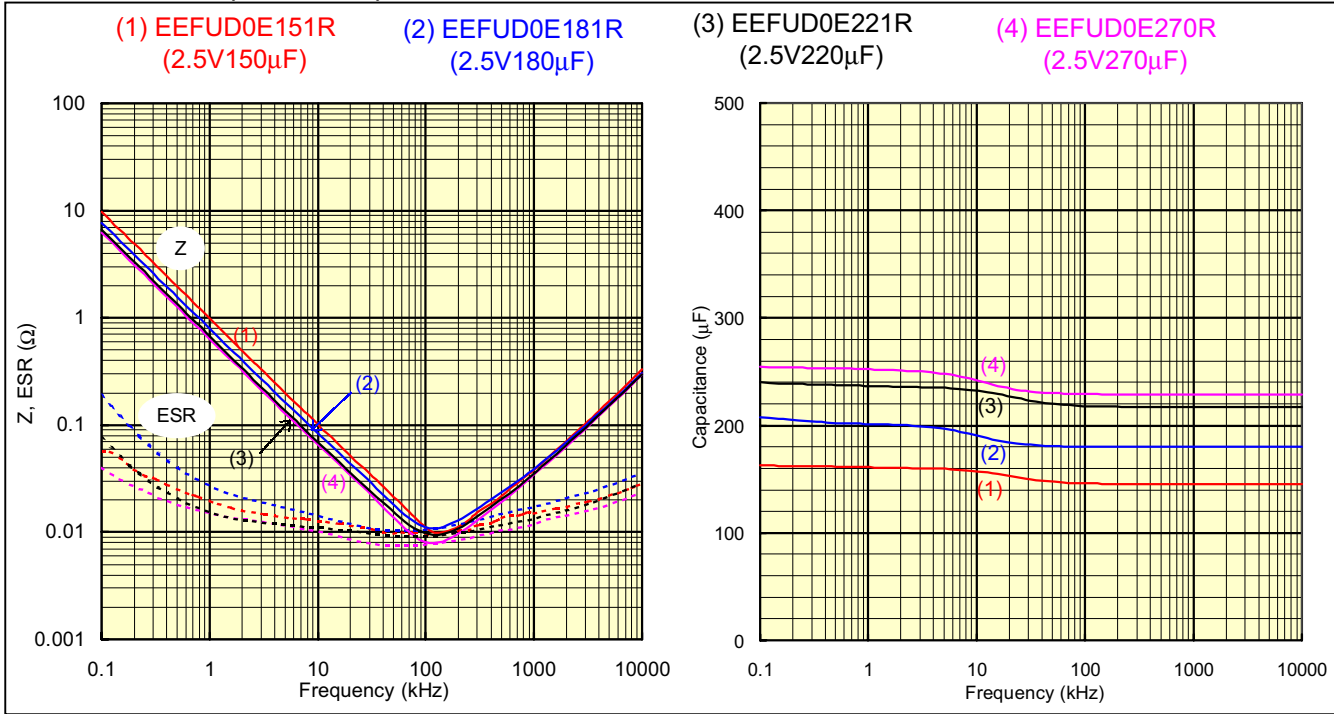

UD Series (4W.V.)

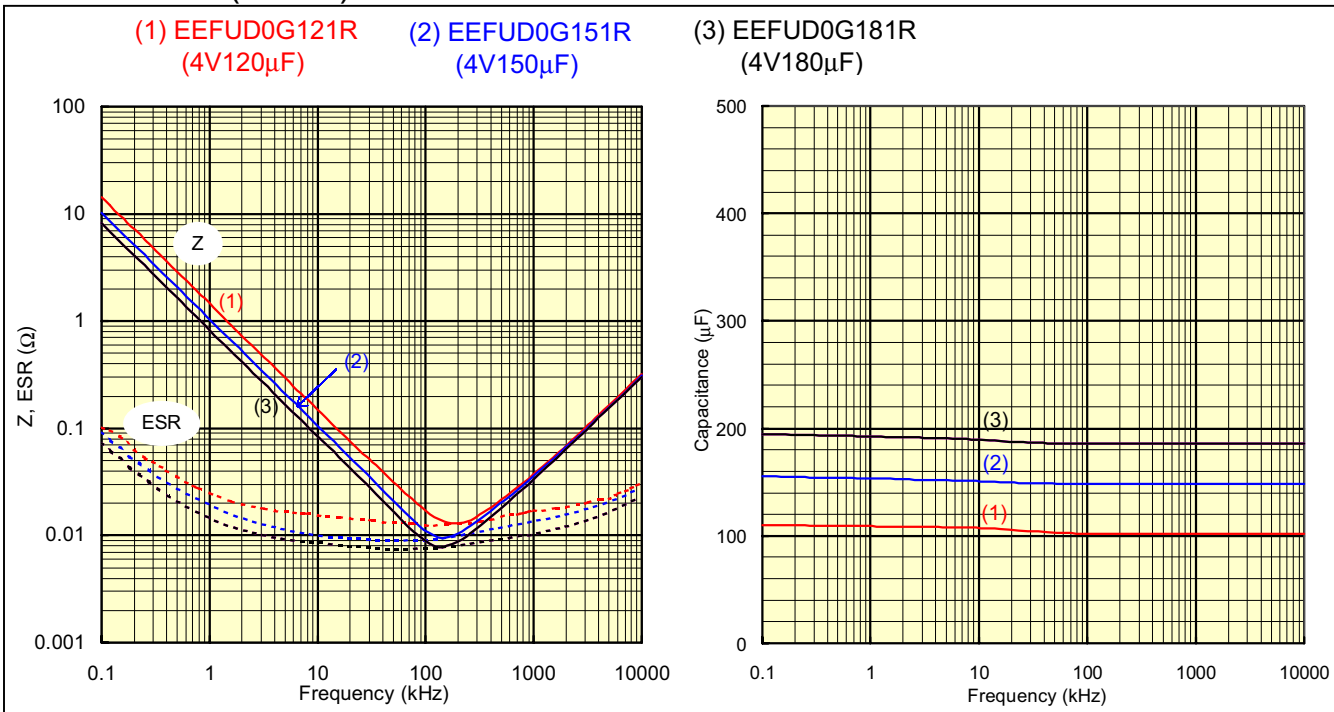

*Please refer to 'Estimation of capacitance-frequency characteristics using the Ladder model' on pg.28



Data

Frequency characteristics*

UD Series (6.3W.V.)

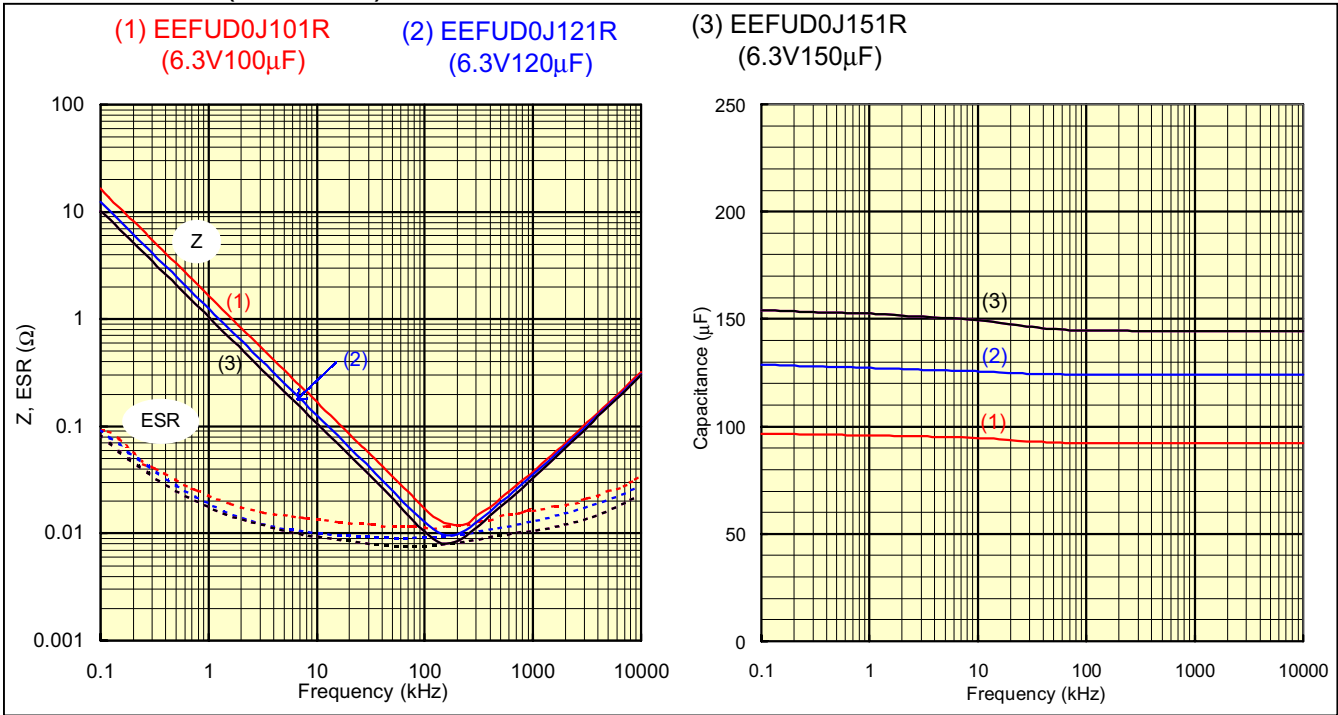

UD Series (8W.V.)

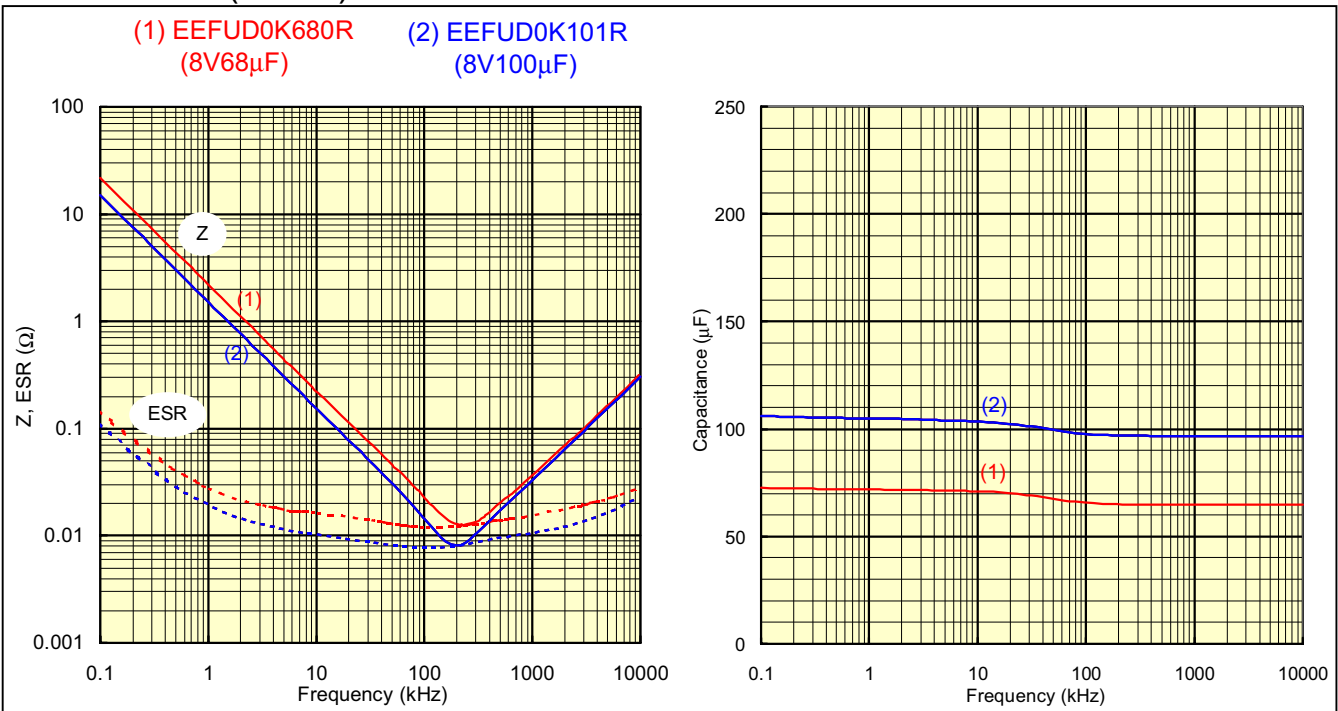

*Please refer to 'Estimation of capacitance-frequency characteristics using the Ladder model' on pg.28



Data

Frequency characteristics*

■ UE Series (2W.V.)

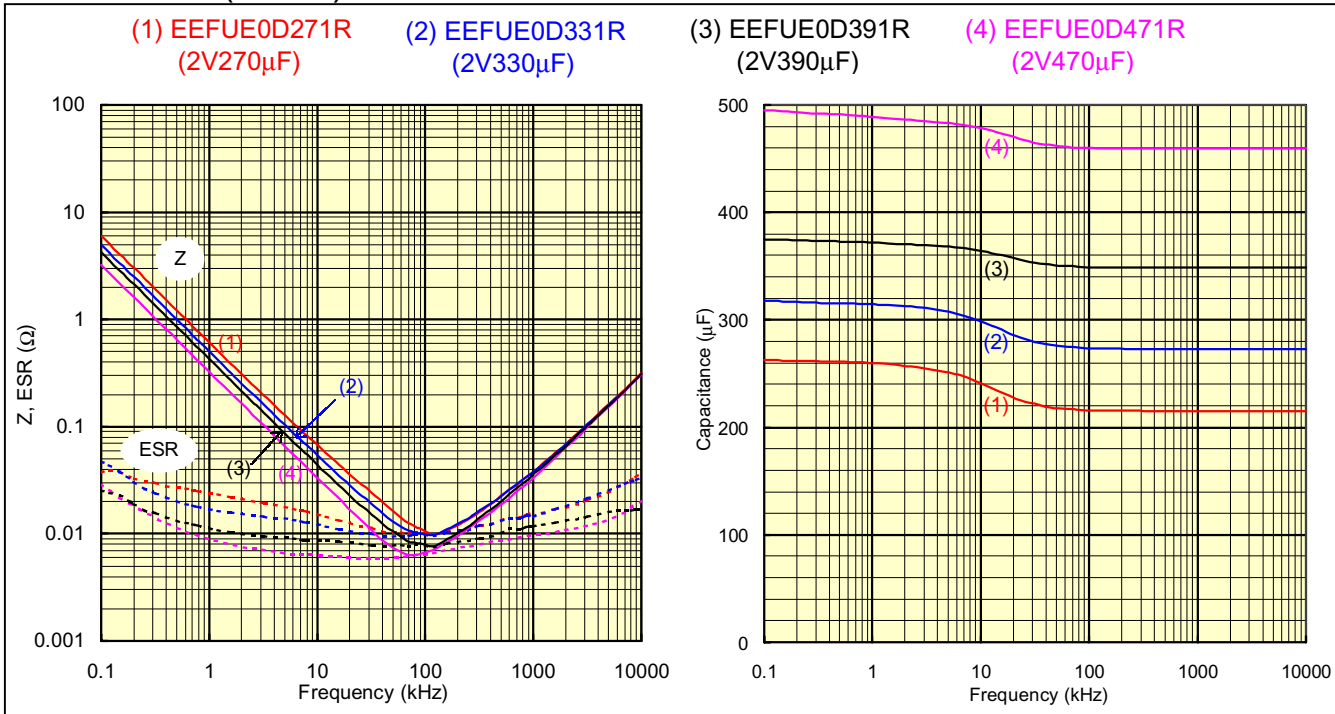

■ UE Series (2.5W.V.)

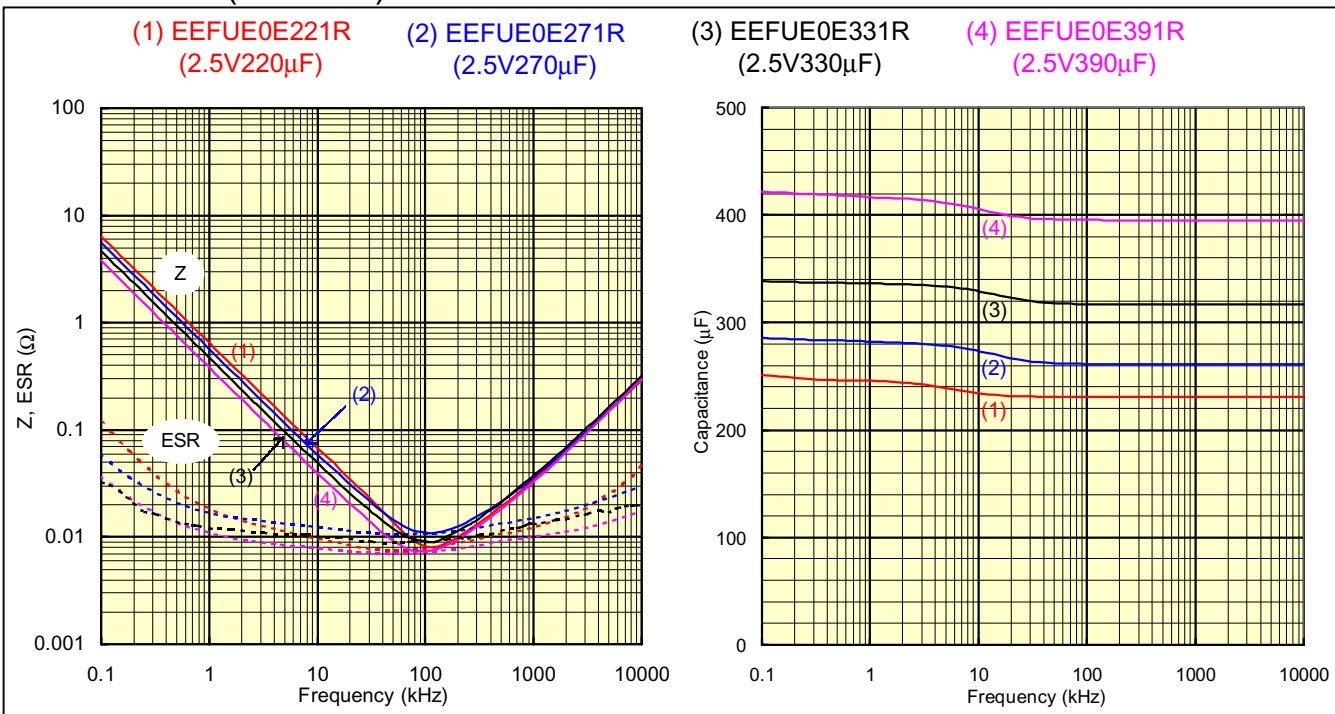

*Please refer to 'Estimation of capacitance-frequency characteristics using the Ladder model' on pg.28



Data

Frequency characteristics*

UE Series (4W.V.)

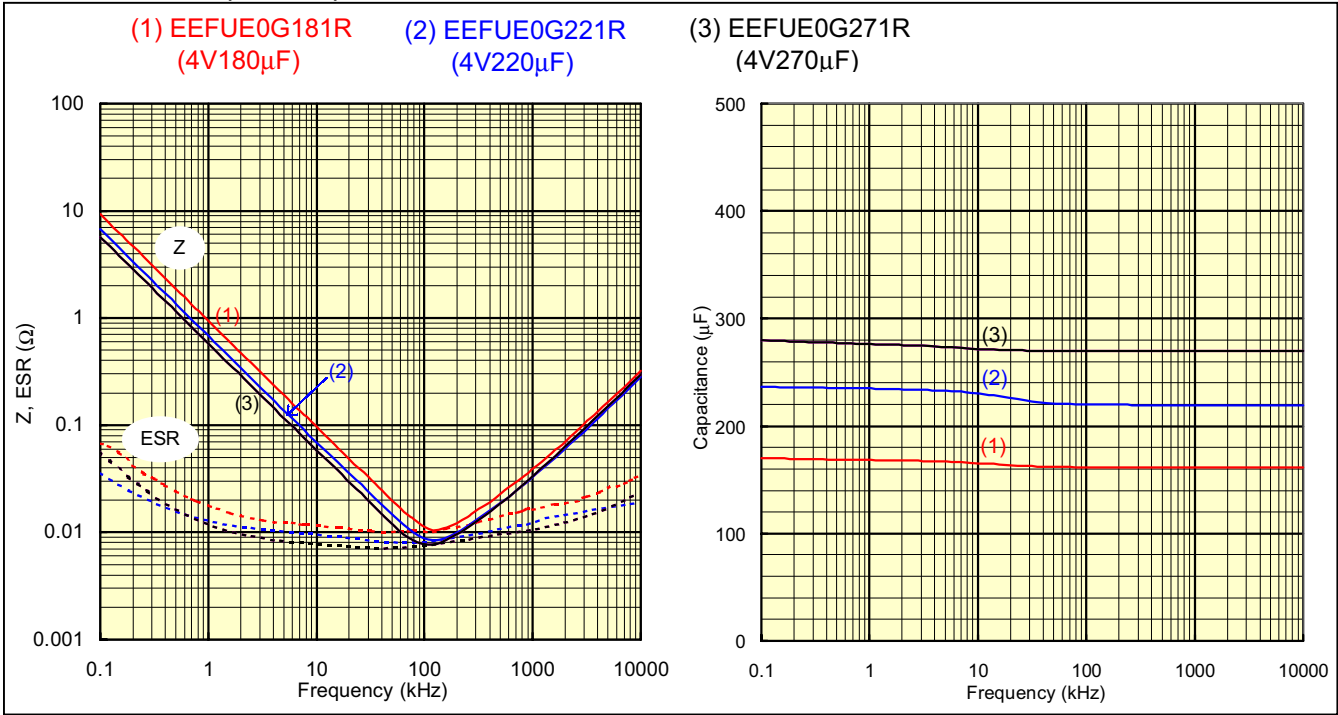

UE Series (6.3 W.V.)

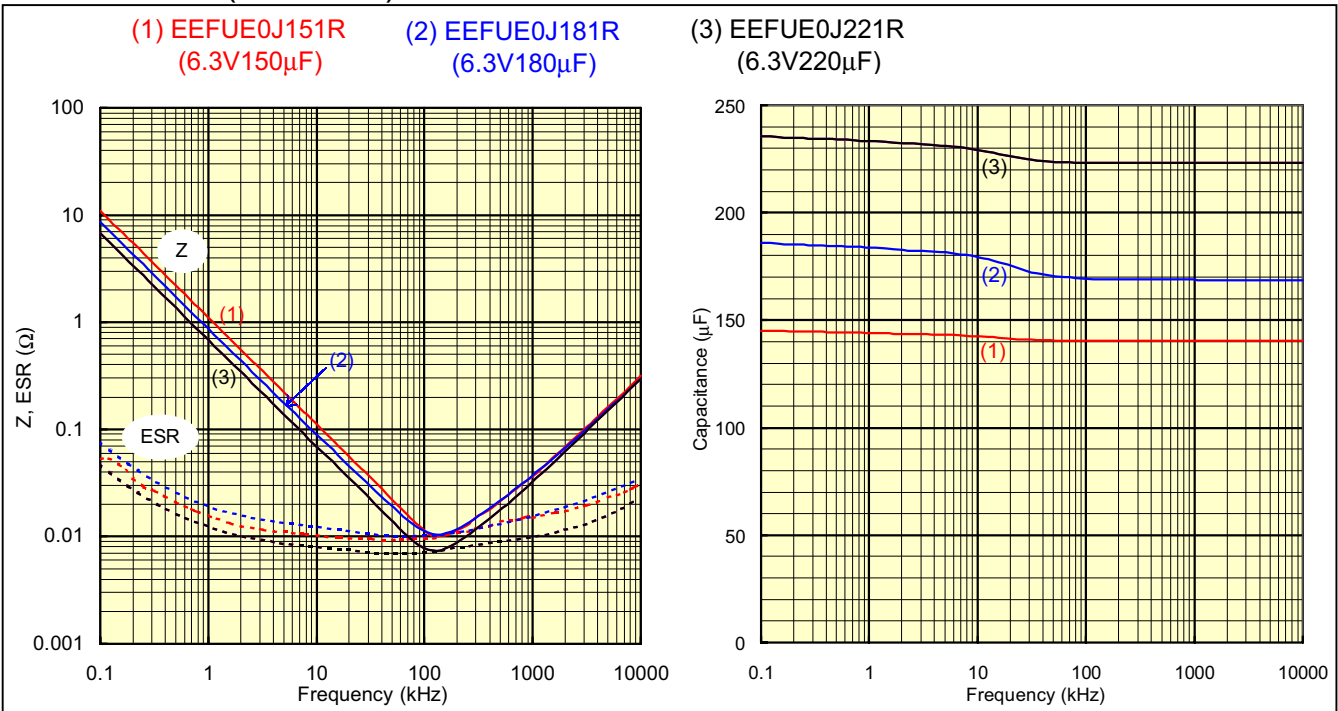

*Please refer to 'Estimation of capacitance-frequency characteristics using the Ladder model' on pg.28



Data

Frequency characteristics*

■ UE Series (8W.V.)

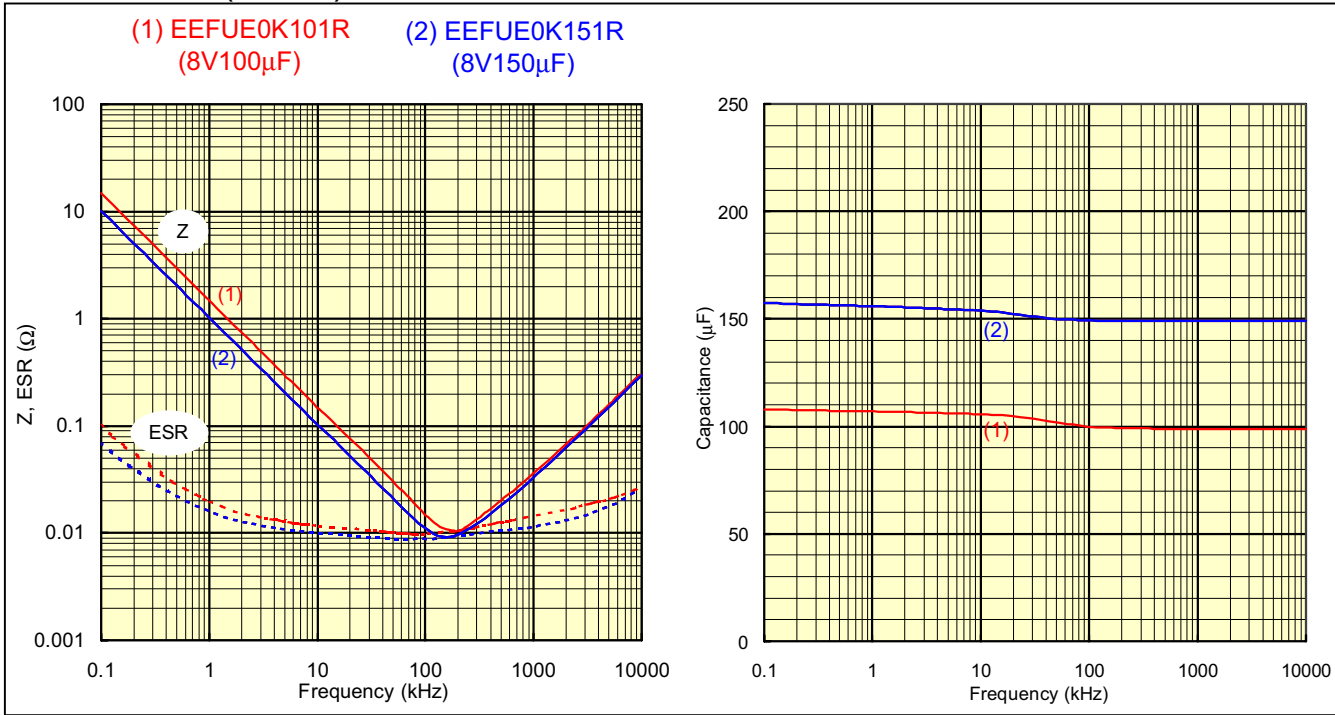

■ FD Series (2, 2.5 W.V.)

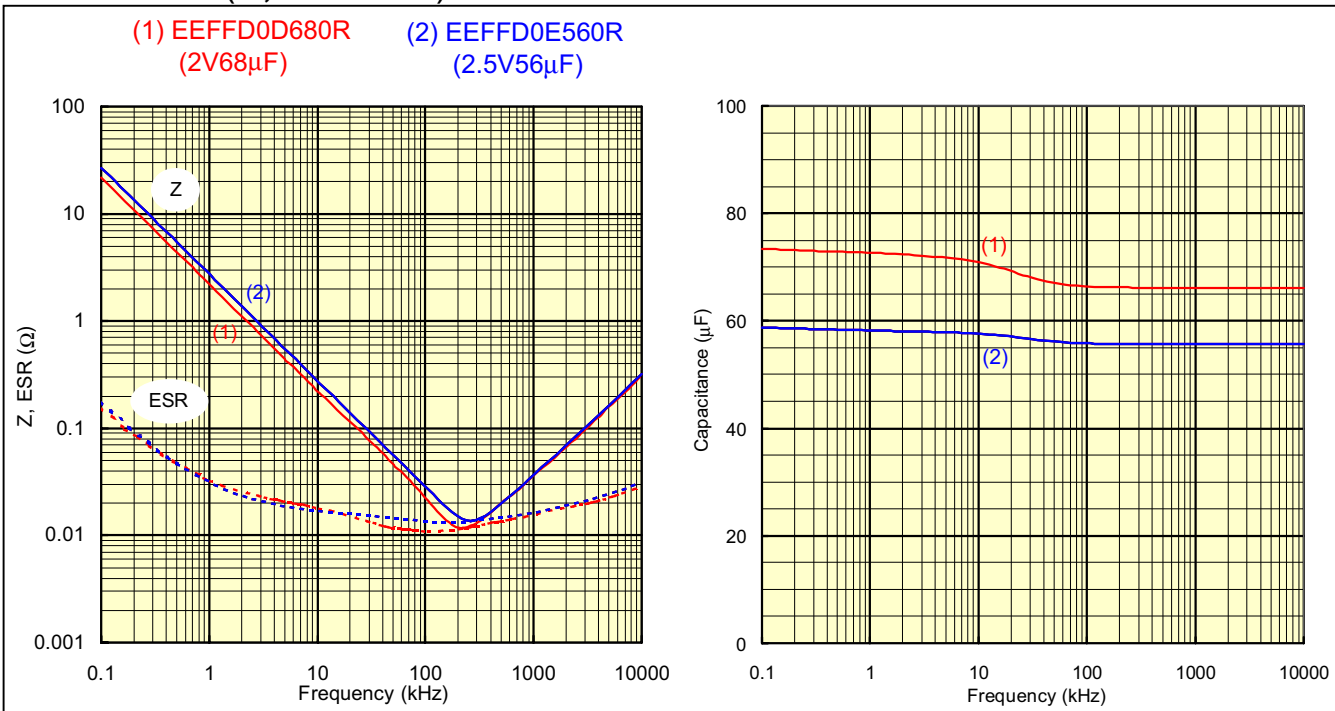

*Please refer to 'Estimation of capacitance-frequency characteristics using the Ladder model' on pg.28



Data

Frequency characteristics*

■ FD Series (4W.V.)

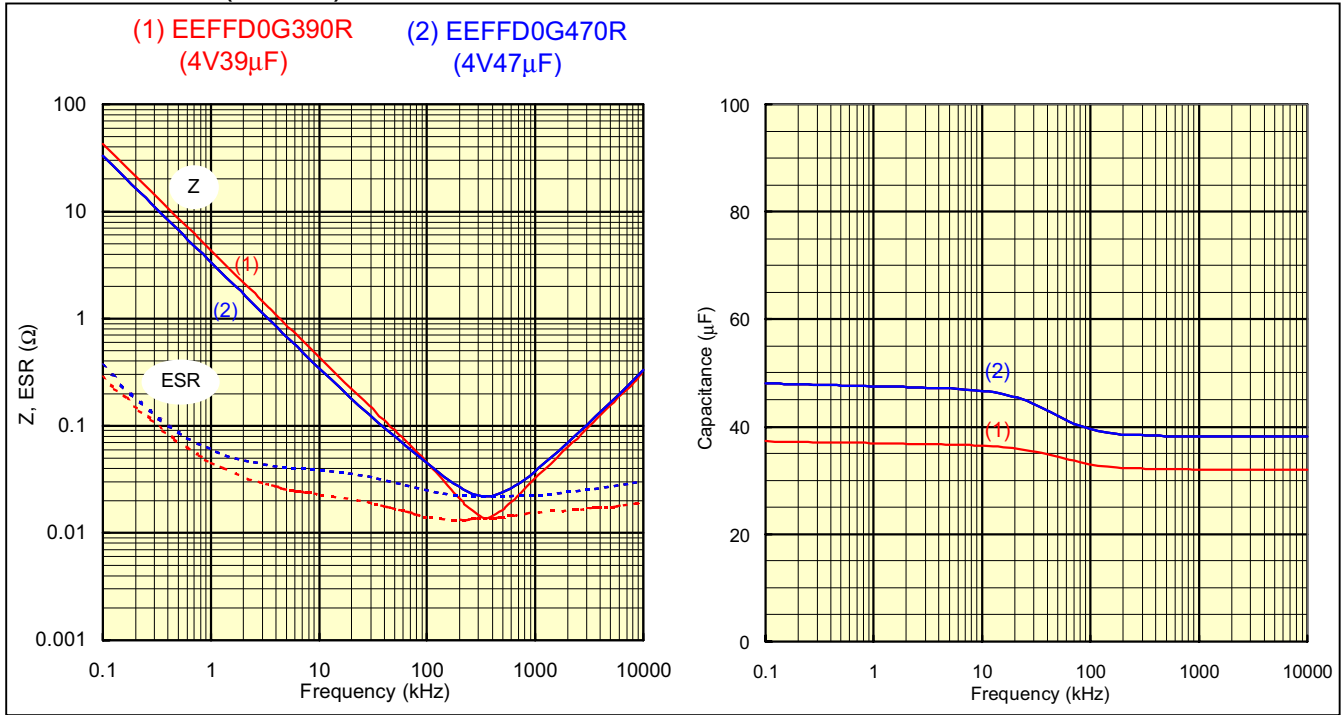

■ FD Series (6.3, 8, 12.5 W.V.)

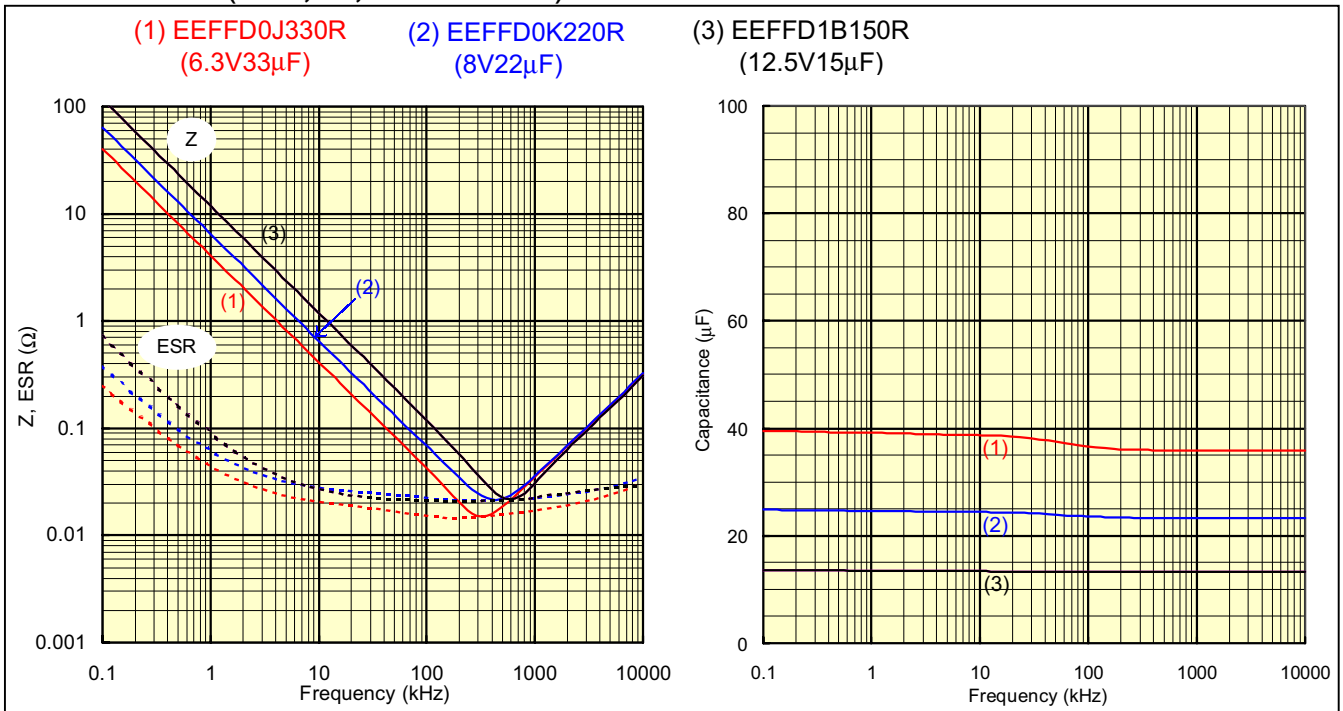

*Please refer to 'Estimation of capacitance-frequency characteristics using the Ladder model' on pg.28



Data

Frequency characteristics*

■ SL Series (2W.V.)

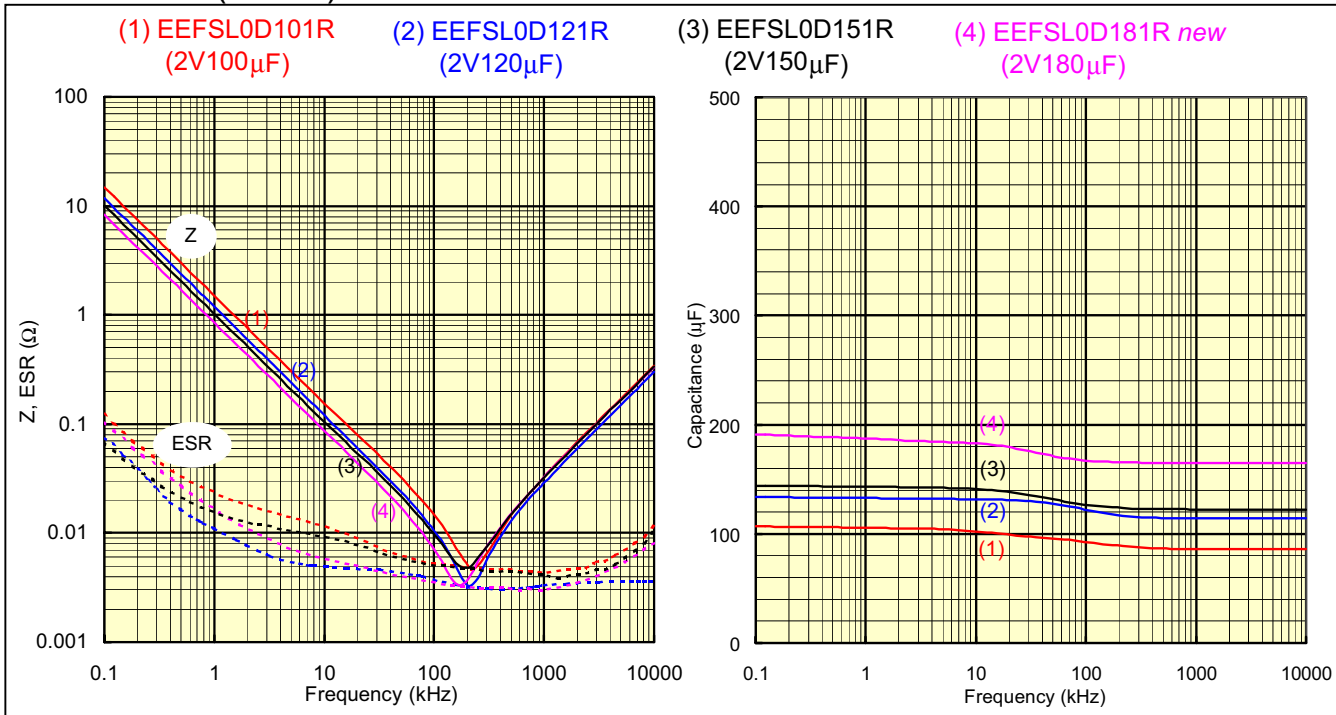

■ SX Series (2W.V.)

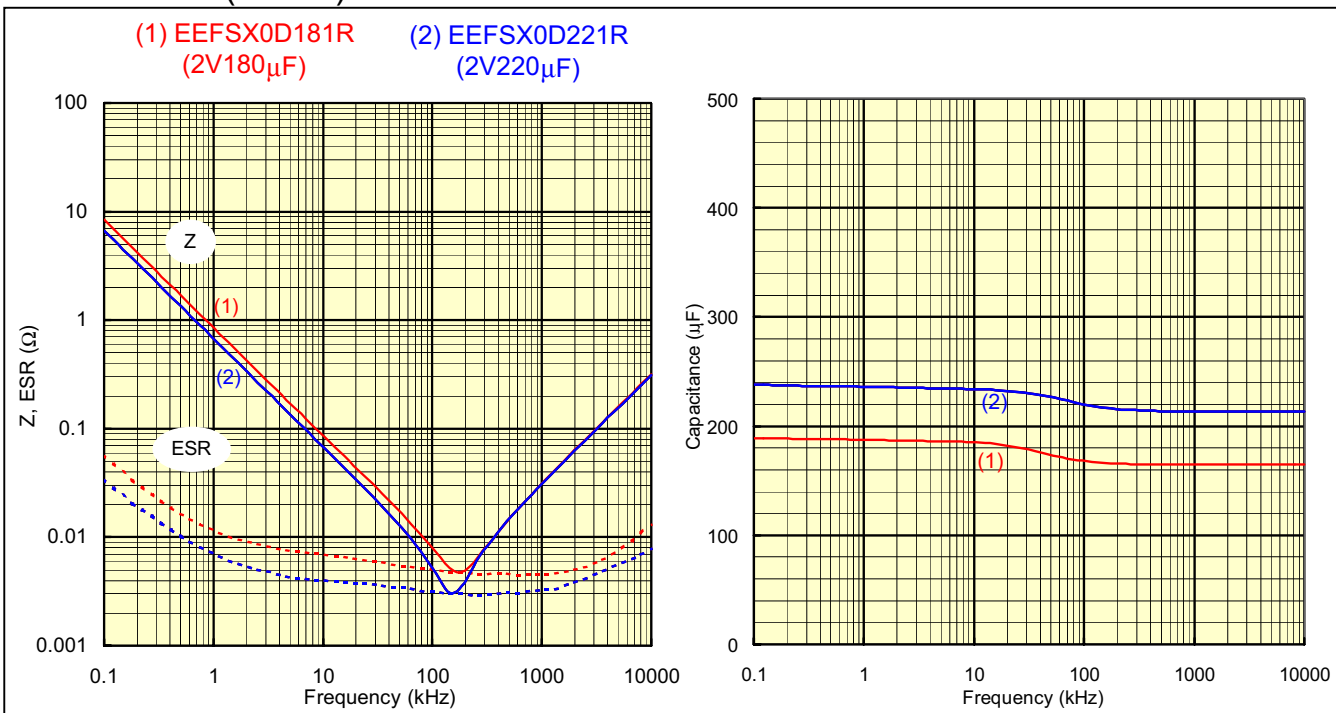

*Please refer to 'Estimation of capacitance-frequency characteristics using the Ladder model' on pg.28

Design and specifications are subject to change without notice. Contact your nearest Panasonic sales office for the latest specifications prior to purchase and/or use. Whenever any doubt or concern about safety arises for this product, please contact us immediately for engineering assistance. Specifications and Data are typical and may not apply to all applications.



Data

Frequency characteristics*

SD Series (2W.V.)

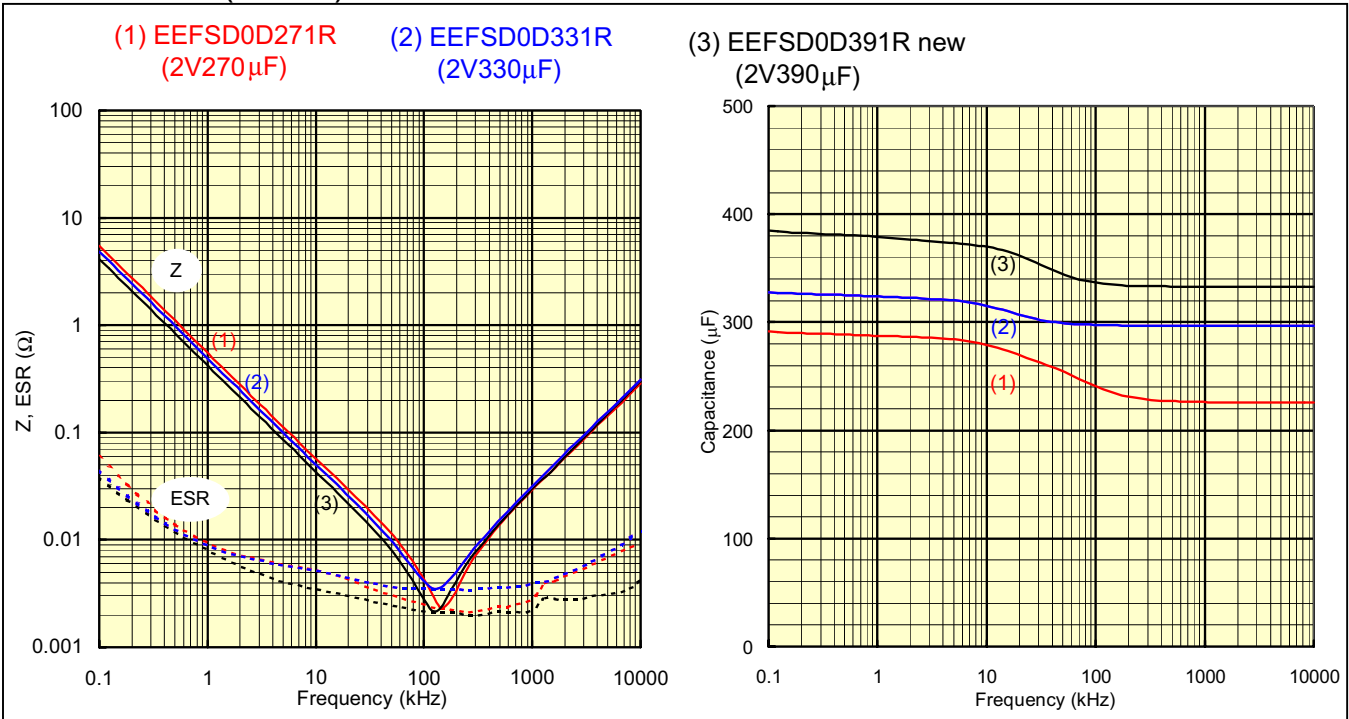

SE Series (2W.V.)

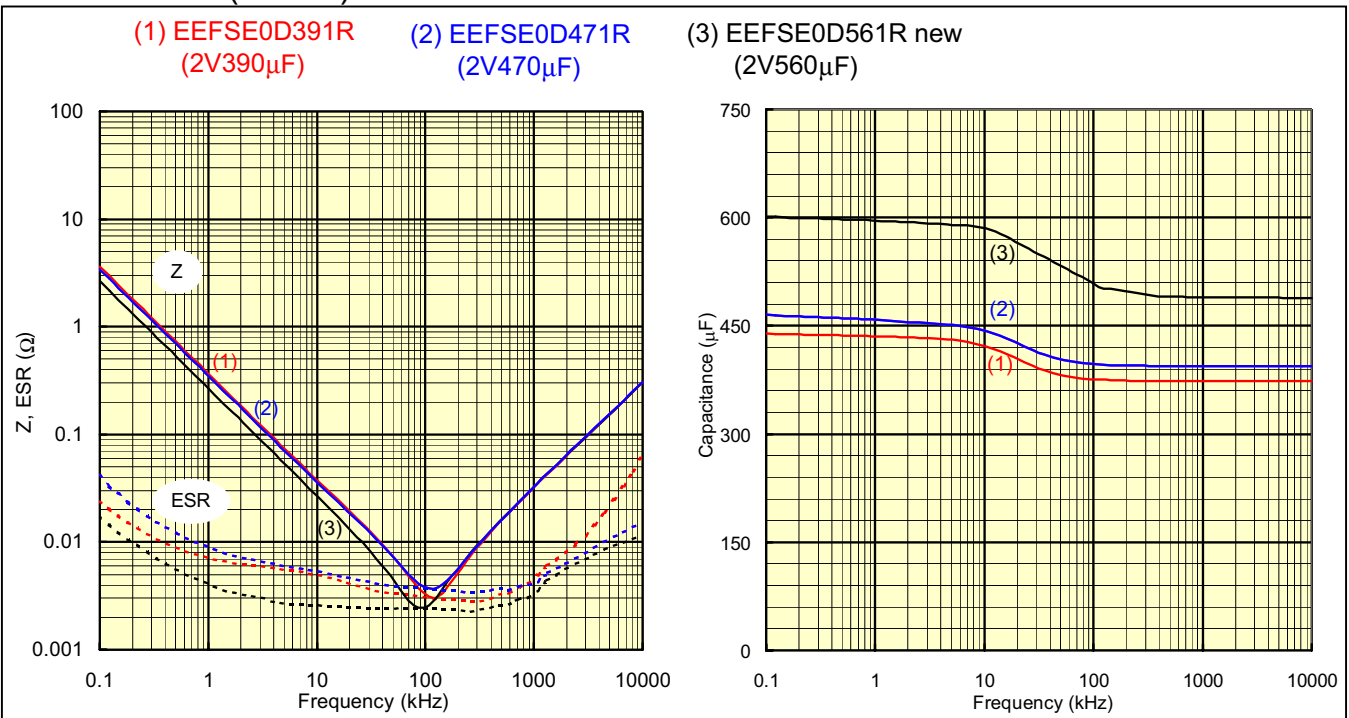

*Please refer to 'Estimation of capacitance-frequency characteristics using the Ladder model' on pg.28

12 Data



Data

Frequency characteristics*

■ SL Series (2.5W.V.)

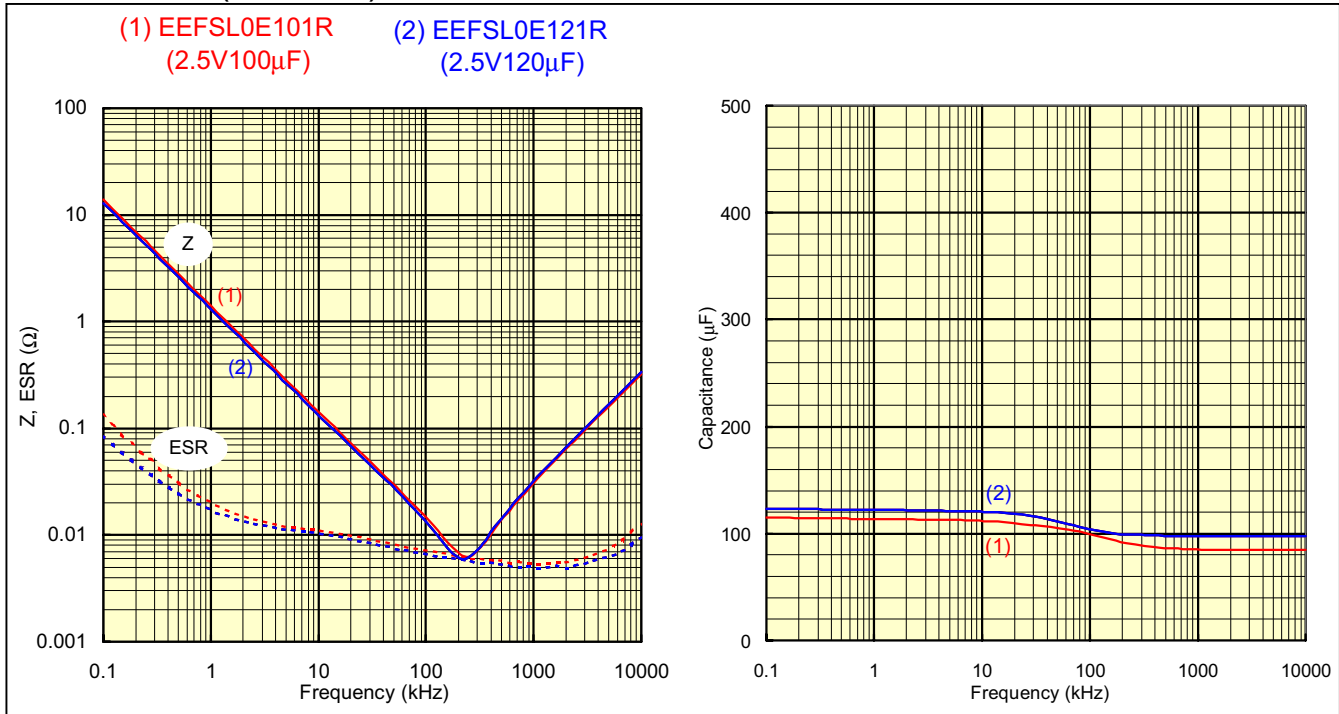

■ SX Series (2.5W.V.)

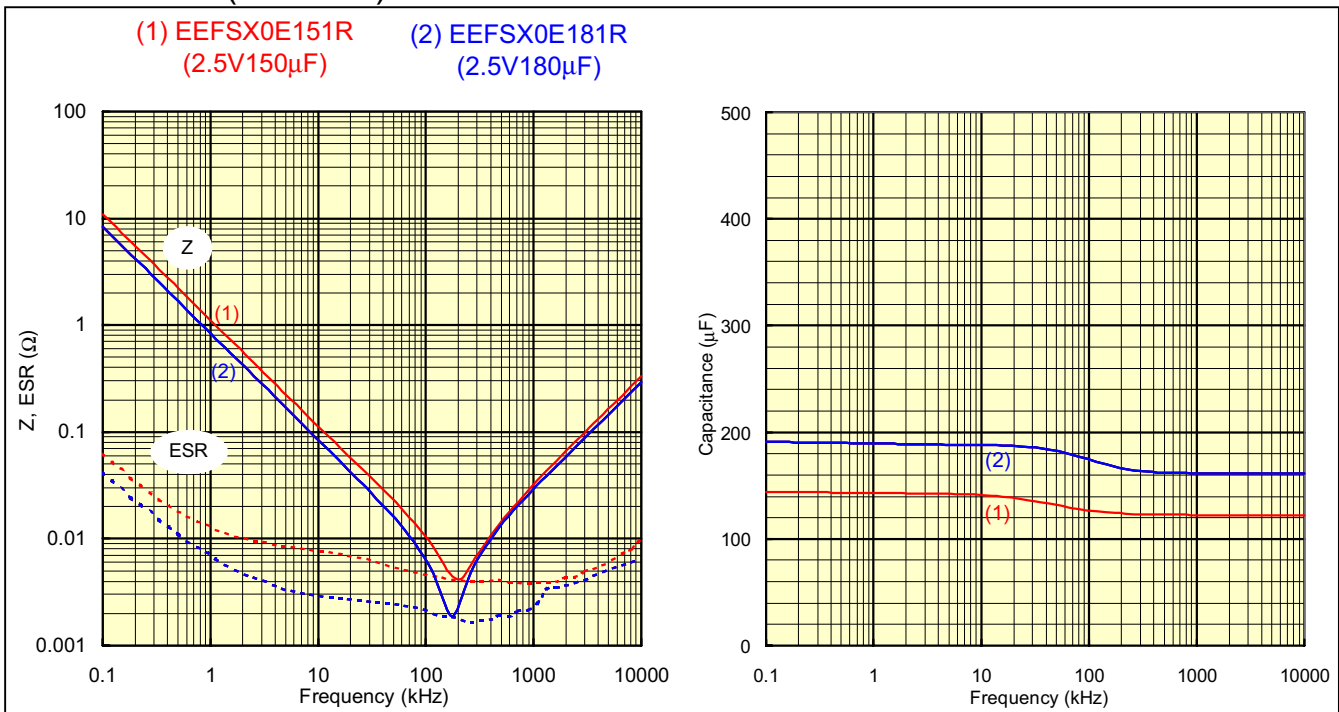

*Please refer to 'Estimation of capacitance-frequency characteristics using the Ladder model' on pg.28



Data

Frequency characteristics*

SD Series (2.5W.V.)

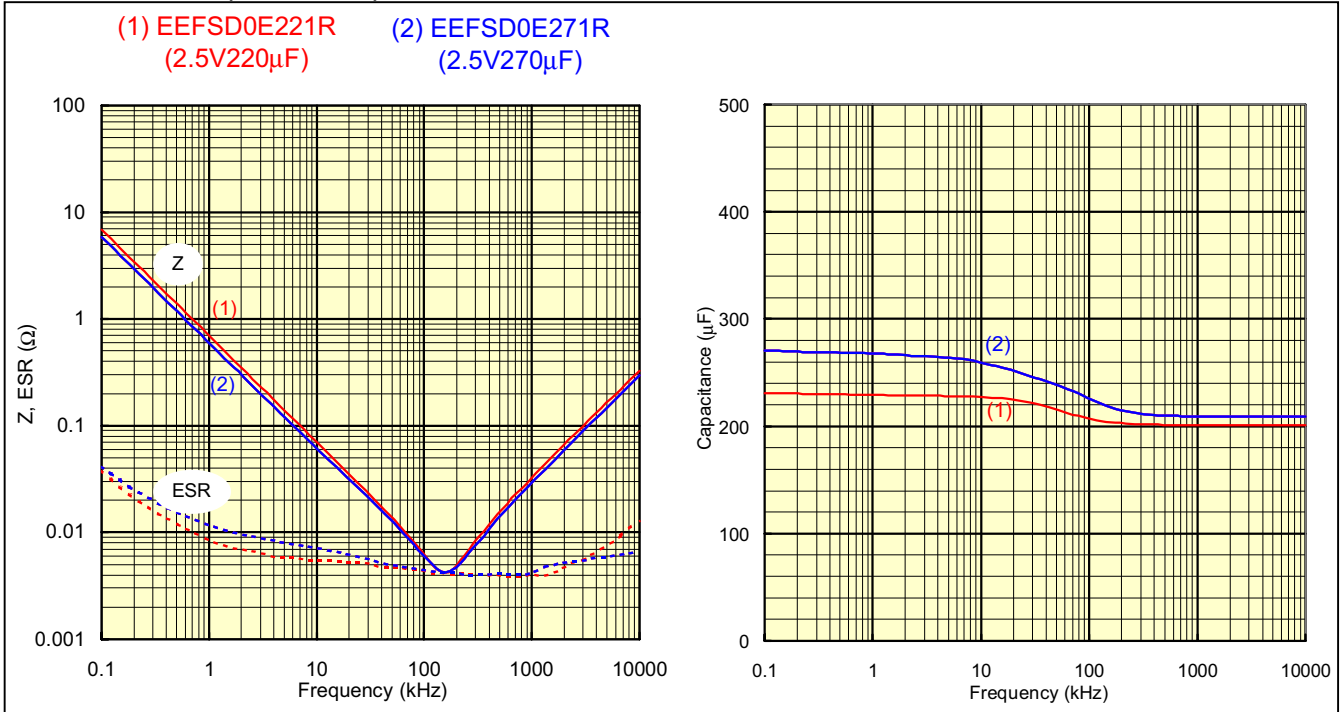

SE Series (2.5W.V.)

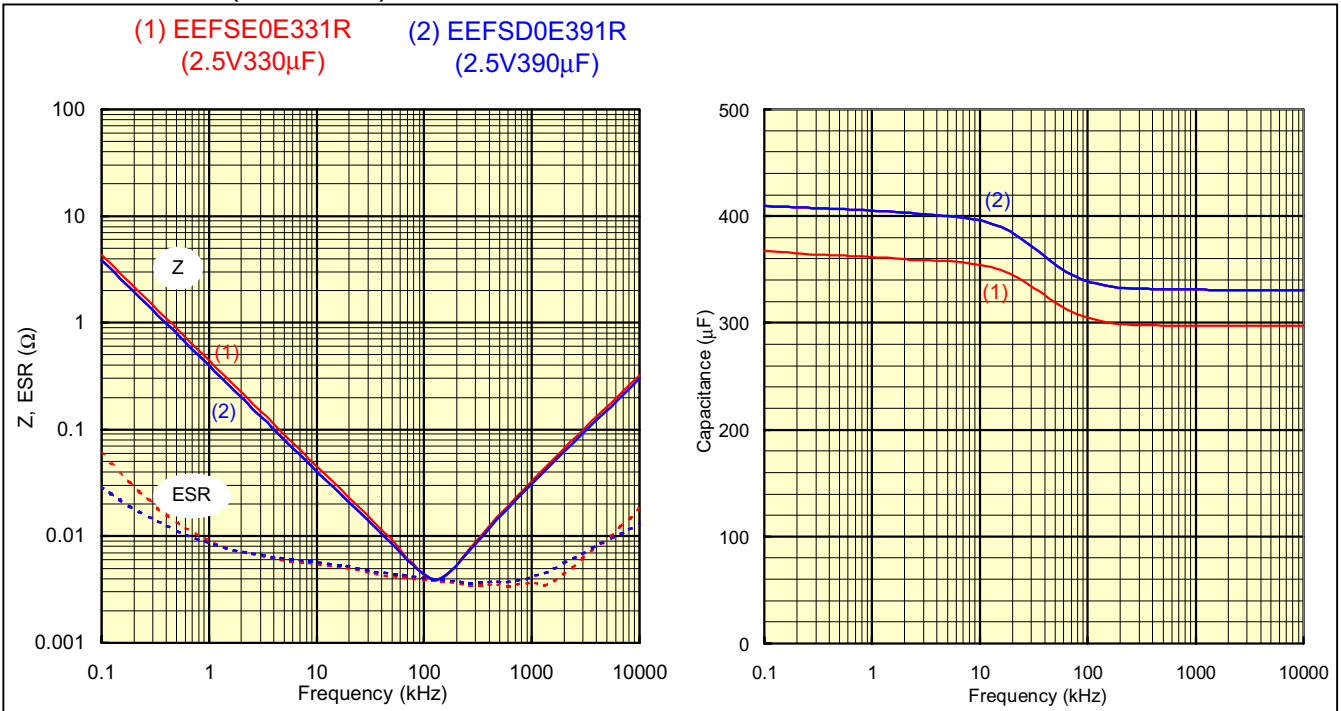

*Please refer to 'Estimation of capacitance-frequency characteristics using the Ladder model' on pg.28



Data

Frequency characteristics*

■ SL, SX Series (4W.V.)

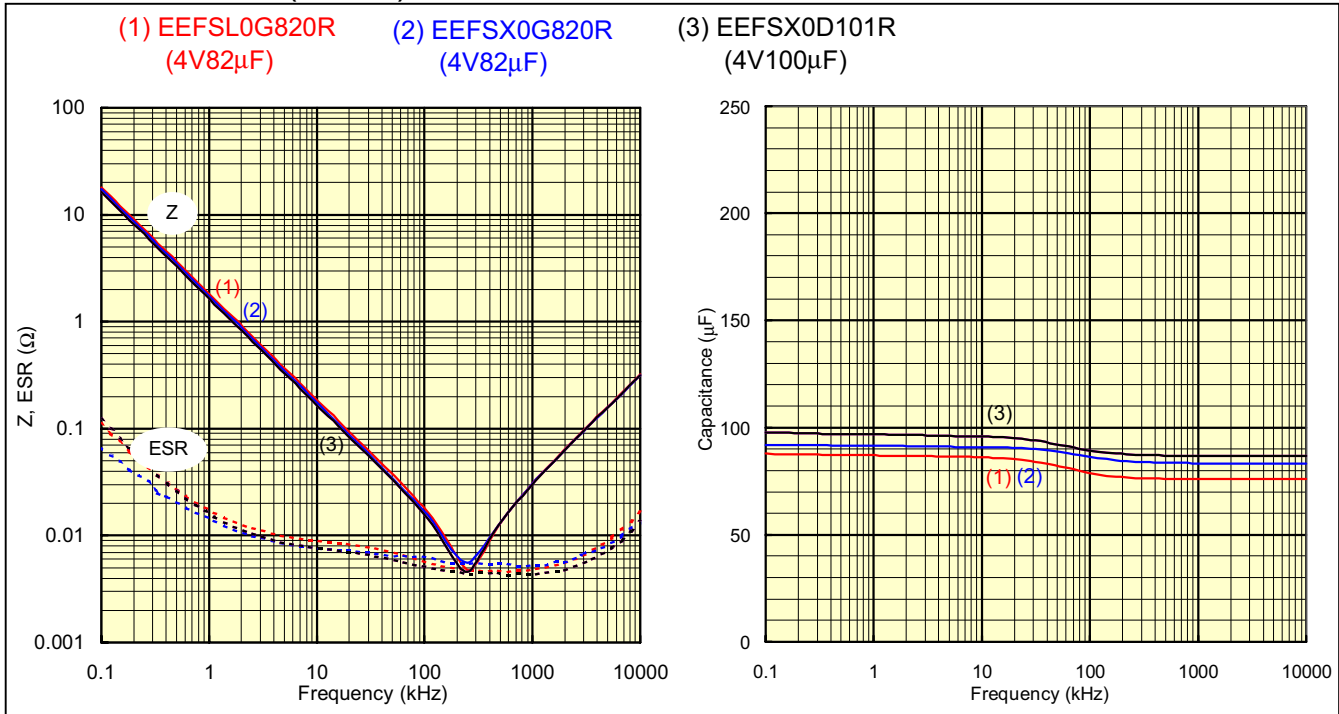

■ SD, SE Series (4W.V.)

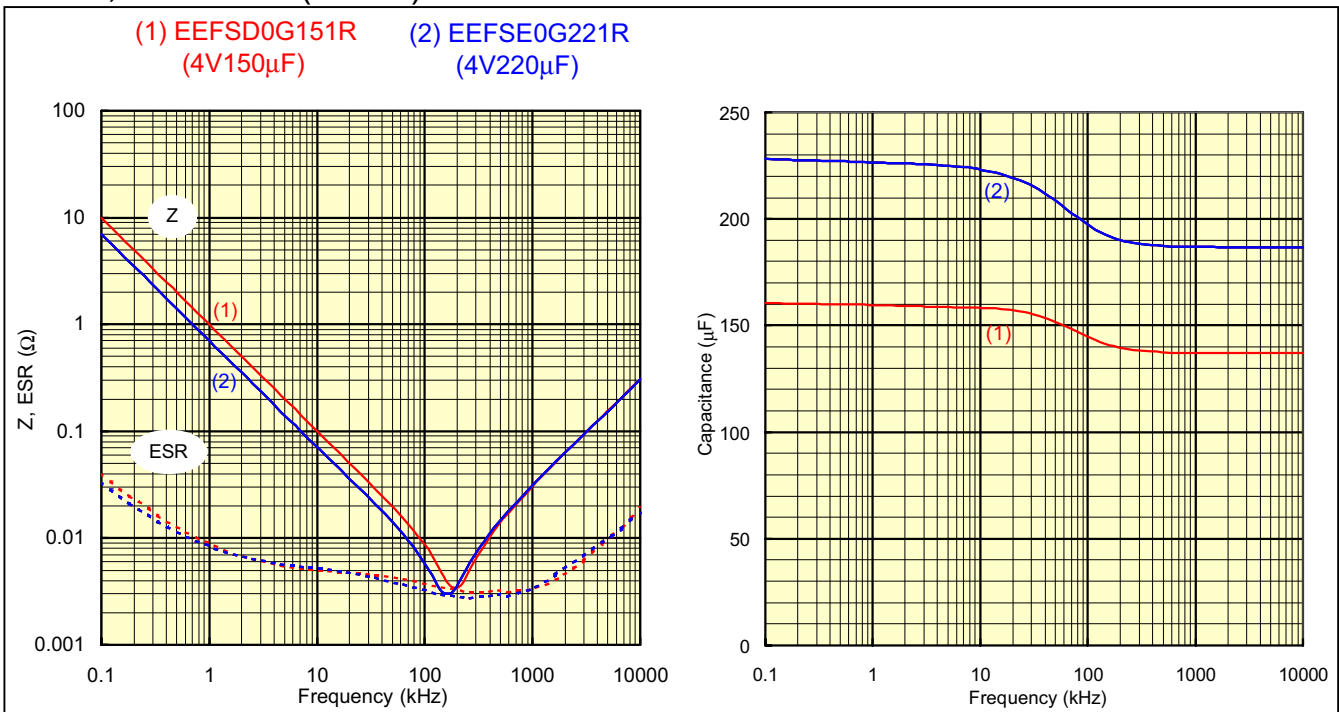

*Please refer to 'Estimation of capacitance-frequency characteristics using the Ladder model' on pg.28



Data

Frequency characteristics*

■ SL, SX Series (6.3W.V.)

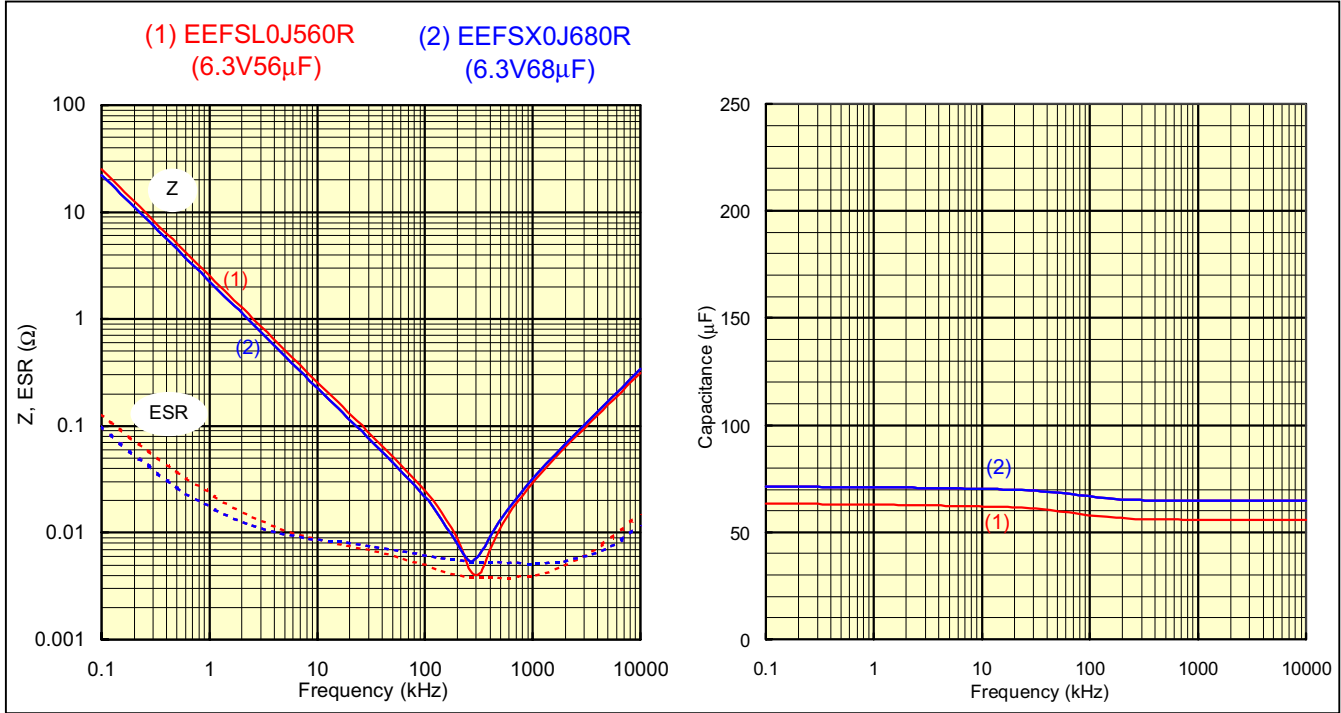

■ SD, SE Series (6.3W.V.)

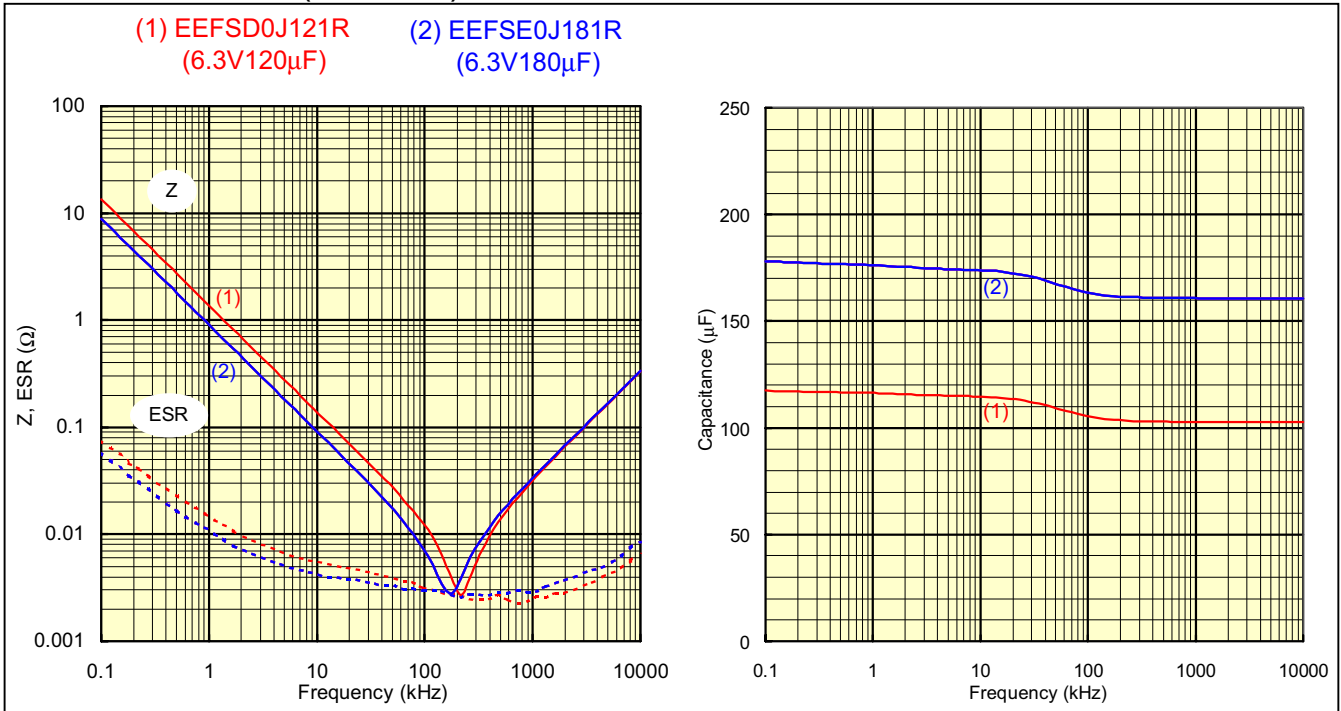

*Please refer to 'Estimation of capacitance-frequency characteristics using the Ladder model' on pg.28



Data

Temperature characteristics

2V68μF:FD Series(EEFFD0D680R)

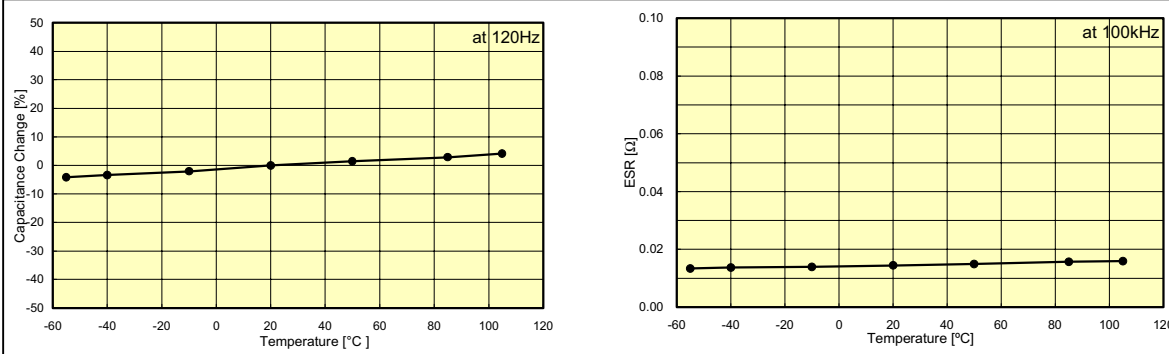

2V120μF:CD Series(EEFCD0D121R)

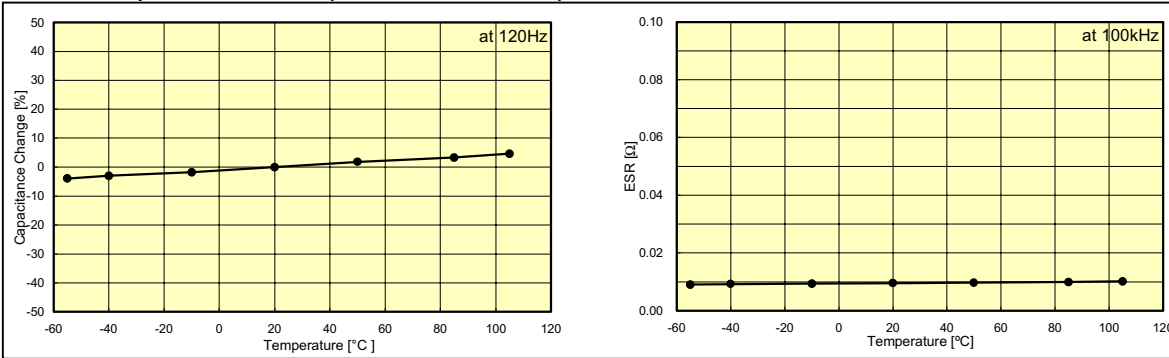

2V270μF:UD Series(EEFUD0D271R)

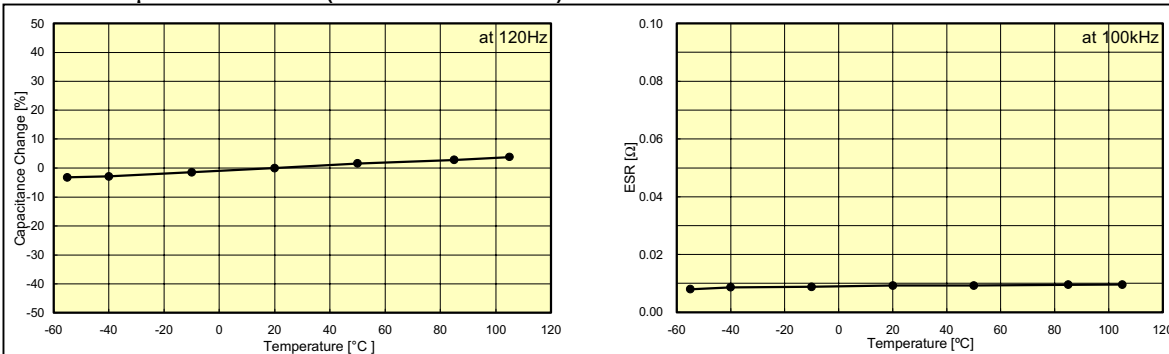

2V390μF:UE Series(EEFUE0D391R)

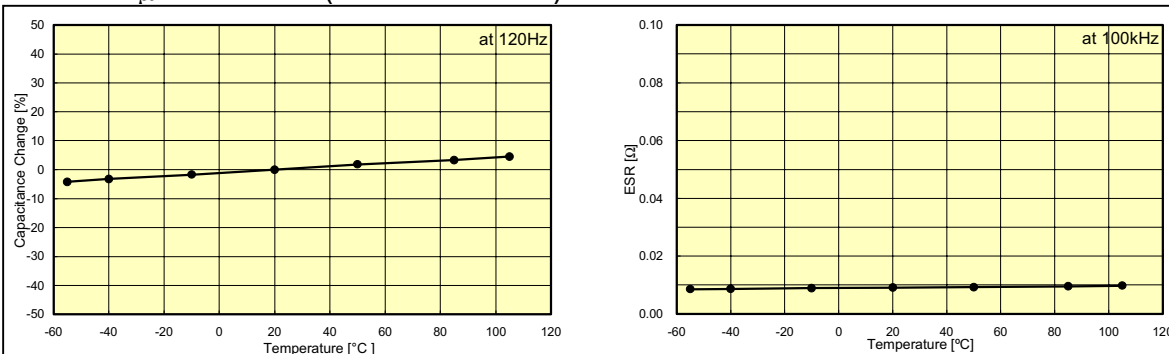



Data

Endurance (with rated voltage applied at +105°C)

CD Series EEFC00D121R (2V120μF)

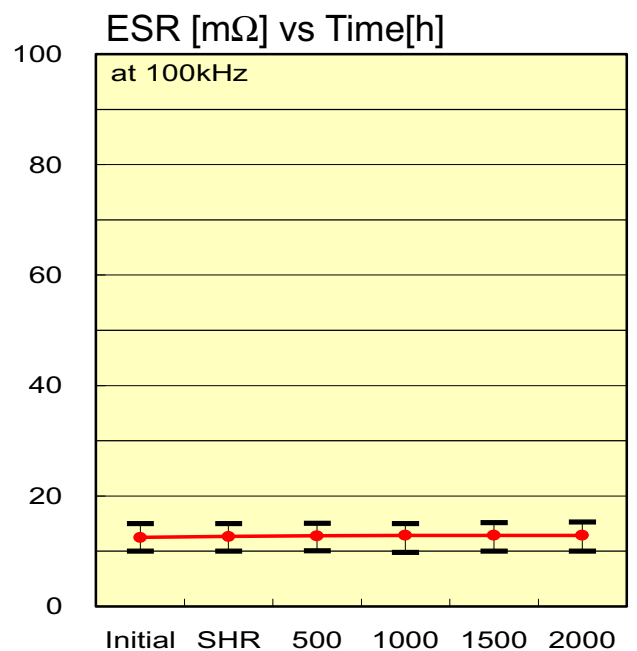
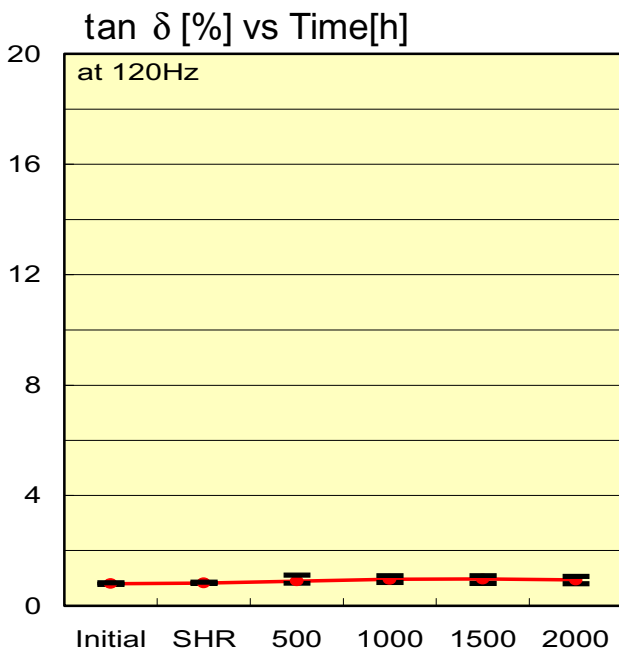
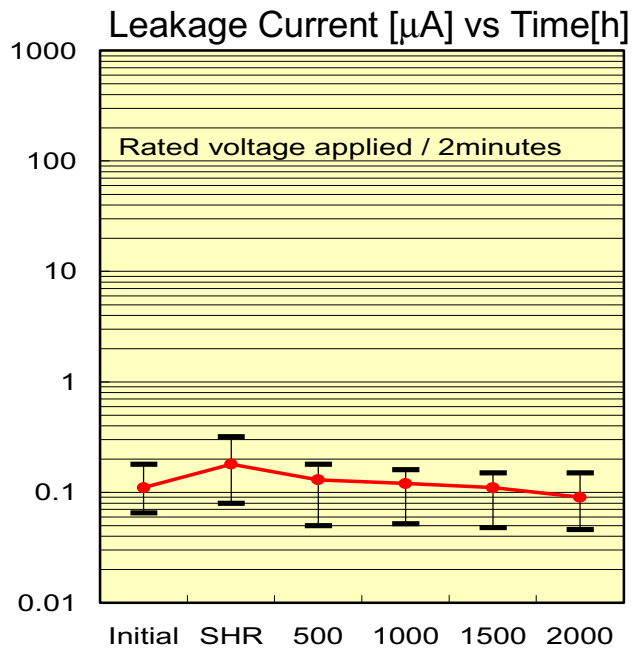
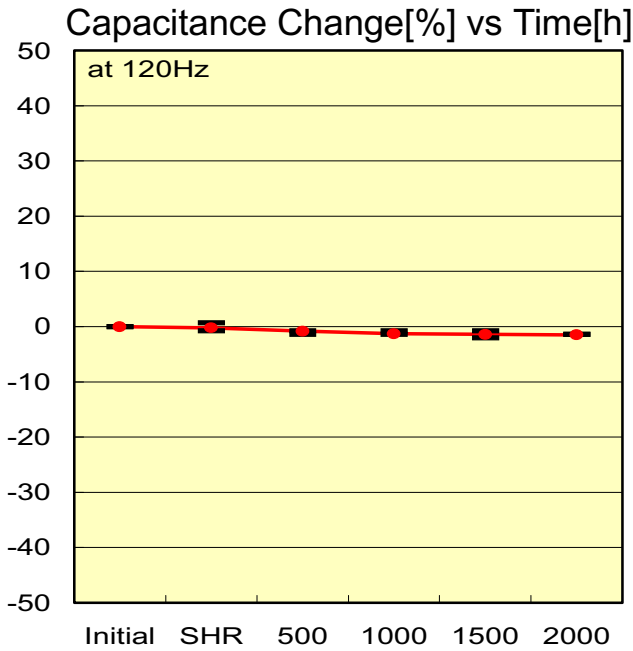



Data

Shelf Life
(with no load at +105°C)

CD Series EEFCD0D121R (2V120μF)

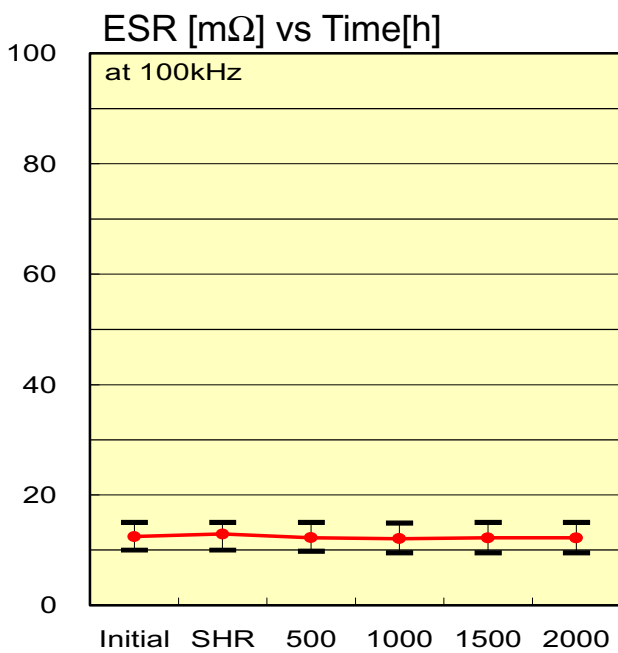
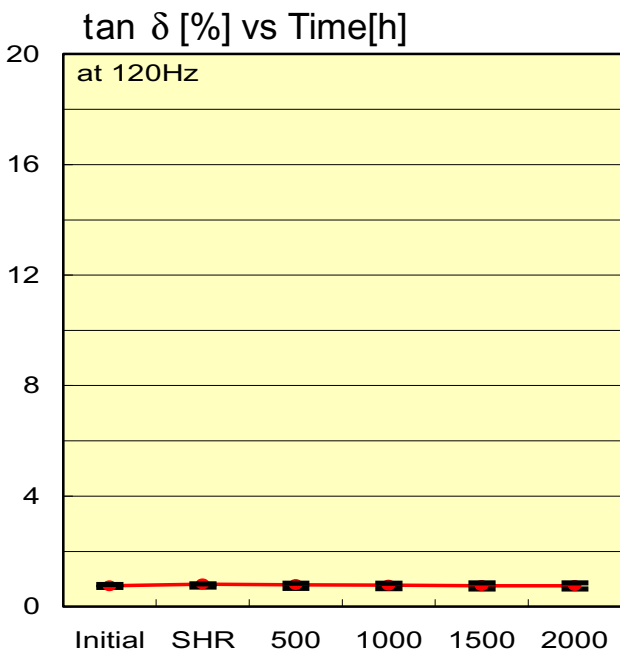
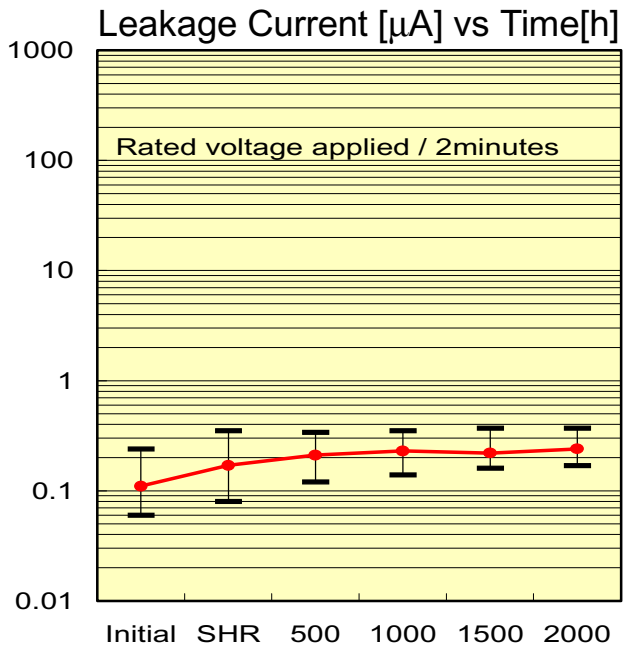
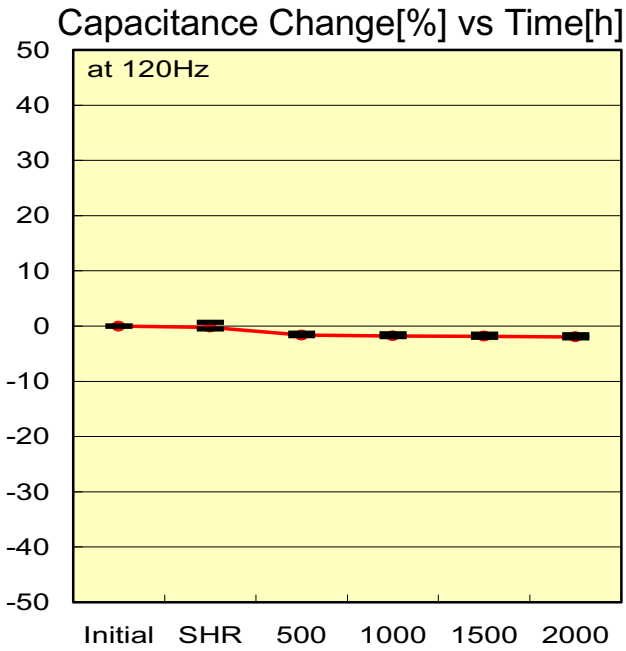



Data

Damp heat , Steady state
(with no load at +60°C, 90%R.H.)

CD Series EEFCD0D121R (2V120μF)

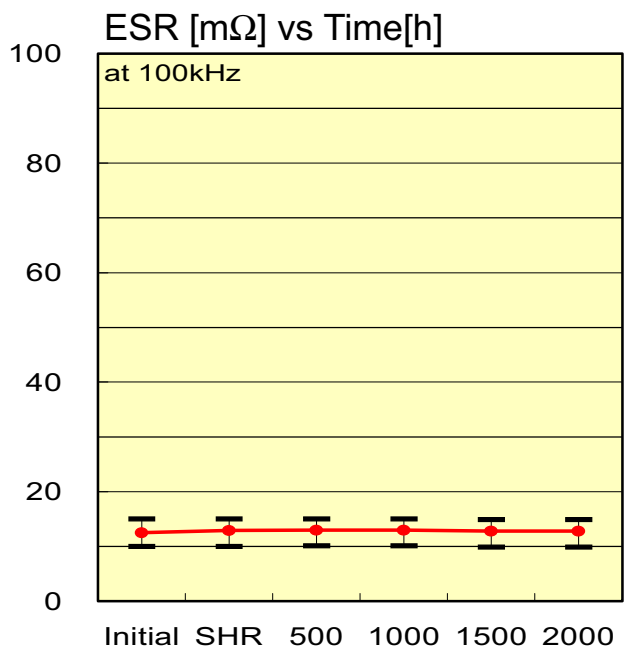
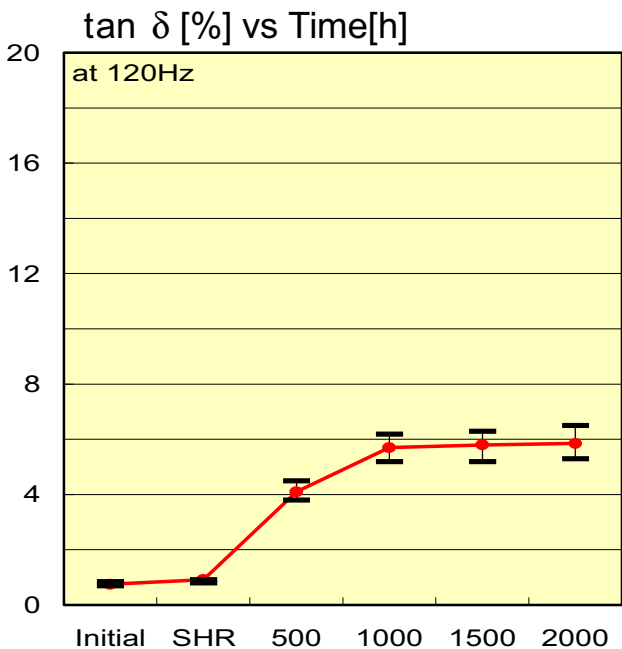
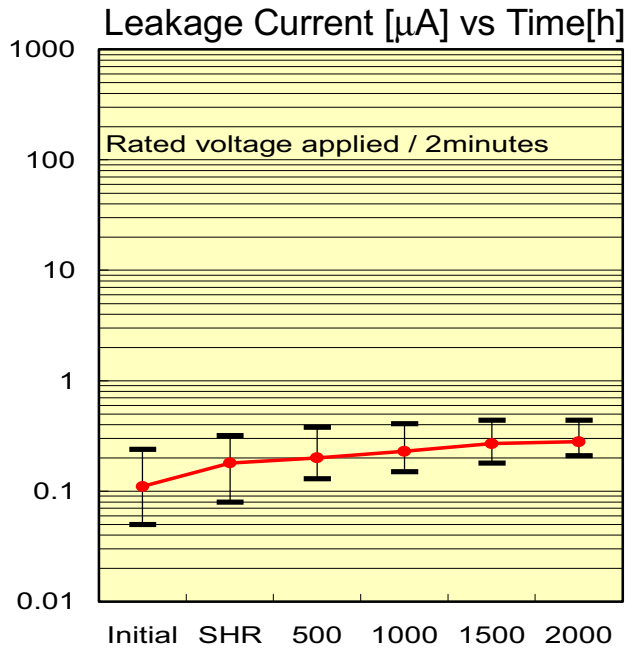
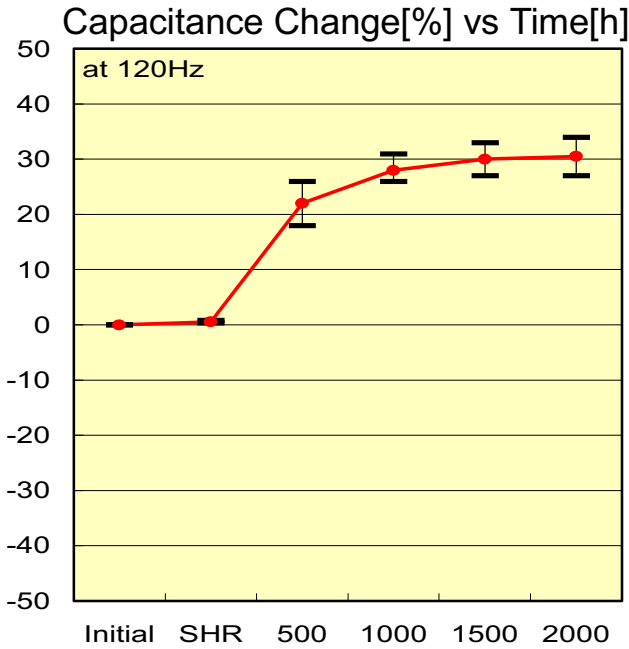

12 Data



Data

Surge voltage (rated voltage x 1.25 times, at room temperature)

CD Series EEFCD0J470R (6.3V47 μ F)

Applied voltage : 8 V

Duty cycle : Charge for 30 seconds and discharge for 5 minutes and 30 seconds

Capacitance Change[%] vs Cycles

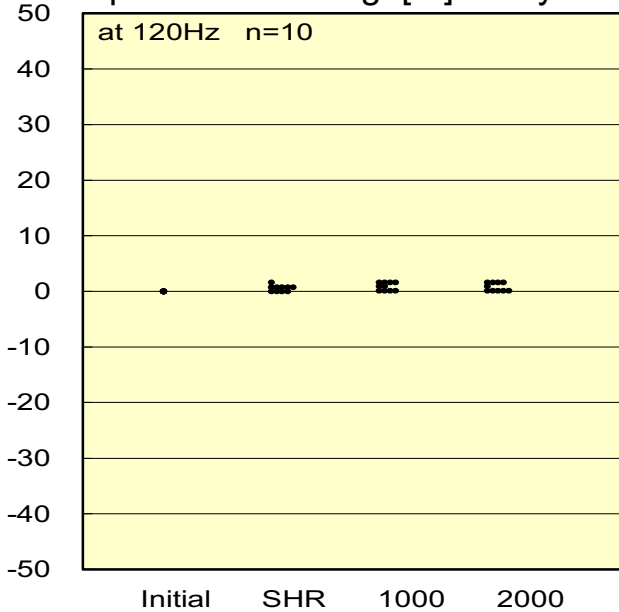

Leakage Current [μ A] vs Cycles

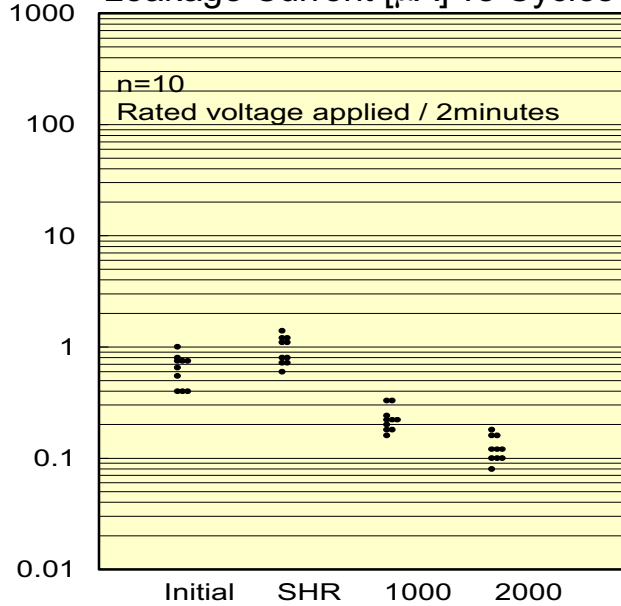

$\tan \delta$ [%] vs Cycles

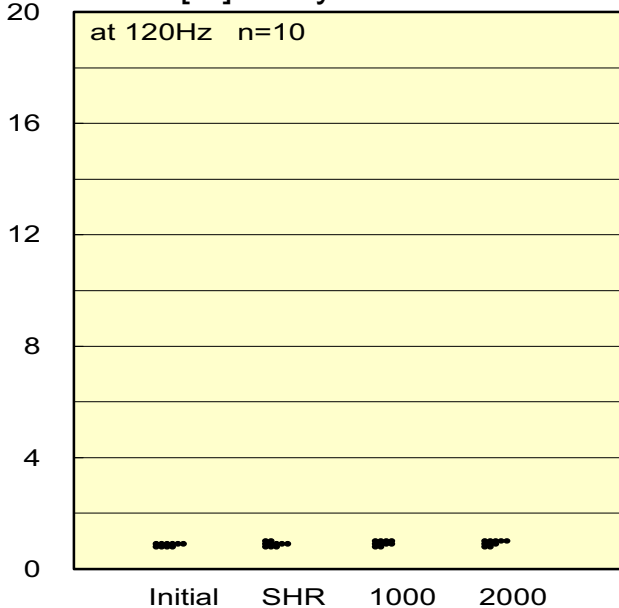

ESR [$m\Omega$] vs Cycles

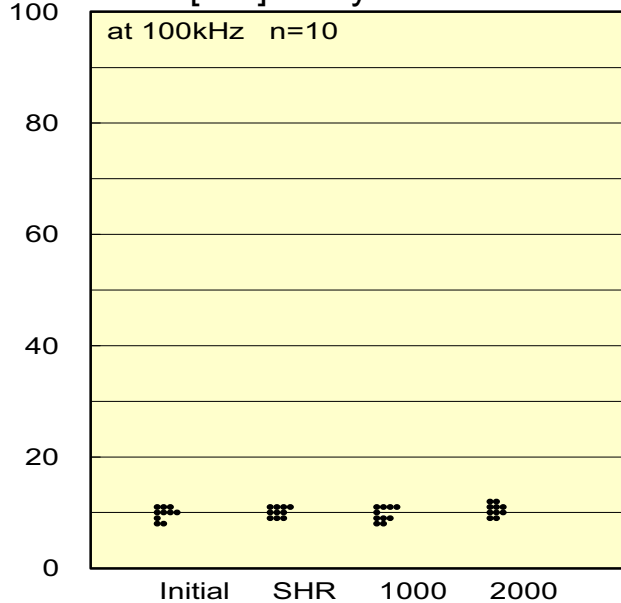



Data

Resistance to Soldering Heat

CD Series EEFCD0D121R (2V120 μ F)

SHR : Peak temperature 240°C, 200°C or higher, 30 seconds, 2 times

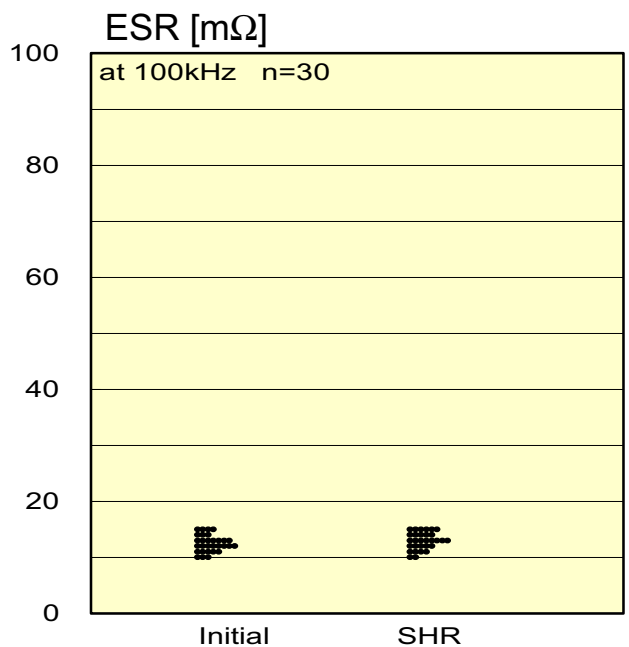
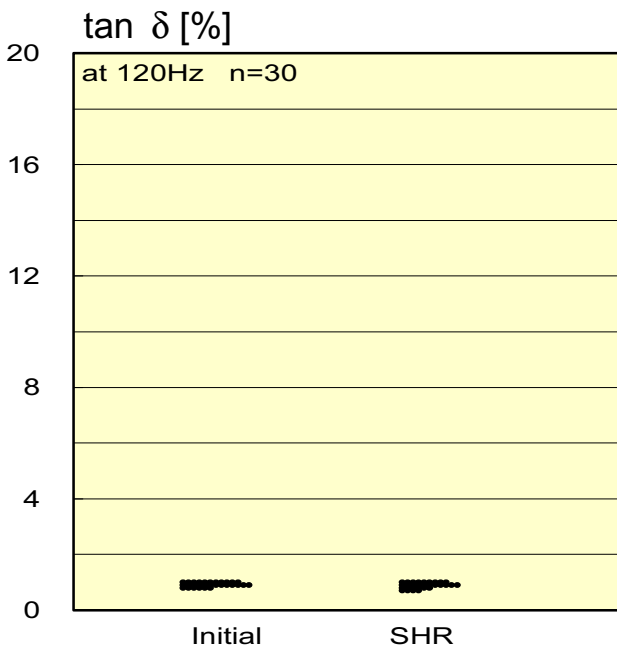
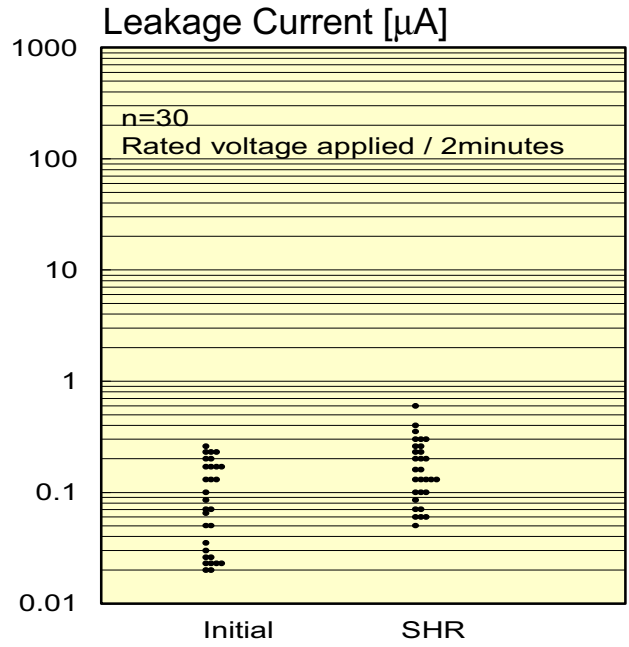
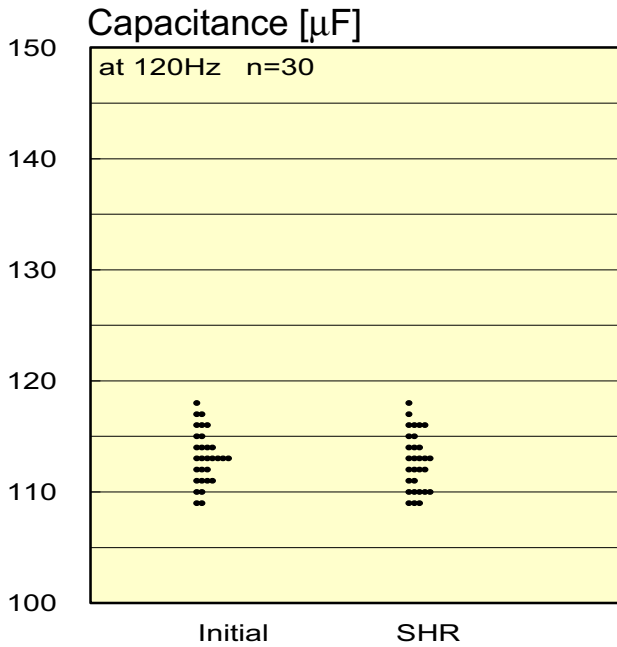

Panasonic Industrial Company

R E G I O N A L S A L E S O F F I C E S

WESTERN REGION:

Panasonic Industrial Co.
15455 N.W. Greenbrier Parkway
Suite 1125
Beaverton, OR 97006

WESTERN REGION:

Panasonic Industrial Co.
2033 Gateway Place
Suite 200
San Jose, CA 95115

WESTERN REGION:

Panasonic Industrial Co.
6550 Katella Ave.
Cypress, CA 90630

WESTERN REGION:

Panasonic Industrial Co.
9444 Balboa Ave.
Suite 185
San Diego, CA 92123

CENTRAL REGION:

Panasonic Industrial Co.
1707 North Randall Rd.
Elgin, IL 60123-7847

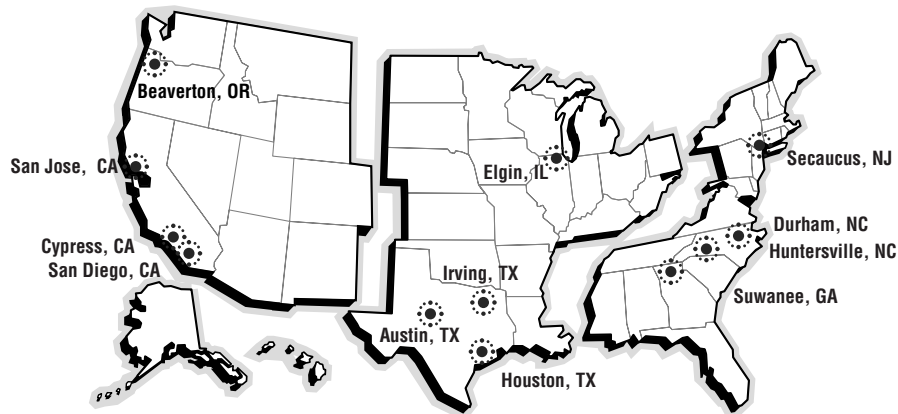

CENTRAL REGION:

Panasonic Industrial Co.
9430 Research Blvd.
Echelon IV, Suite 308
Austin, TX 78759

CENTRAL REGION:

Panasonic Industrial Co.
1405 S Beltline Rd.
Suite 300
Coppell, TX 75019

CENTRAL REGION:

Panasonic Industrial Co.
8300 West FM 1960
Suite 200
Houston, TX 77070

EASTERN REGION:

Panasonic Industrial Co.
Two Panasonic Way
Secaucus, NJ 07094

EASTERN REGION:

Panasonic Industrial Co.
1000 Park 40 Plaza
Suite 220
Durham, NC 27713

EASTERN REGION:

Panasonic Industrial Co.
10115 Kinsey Ave.
Storrs Bldg, Suite 100
Huntersville, NC 28078

EASTERN REGION:

Panasonic Industrial Co.
1225 Northbrook Parkway
Suite # 1-151
Suwanee, GA 30024