



POWERED BY

Panasonic

Electronic Components

PAN1315ETU DESIGN GUIDE

www.panasonic.com/rfmodules

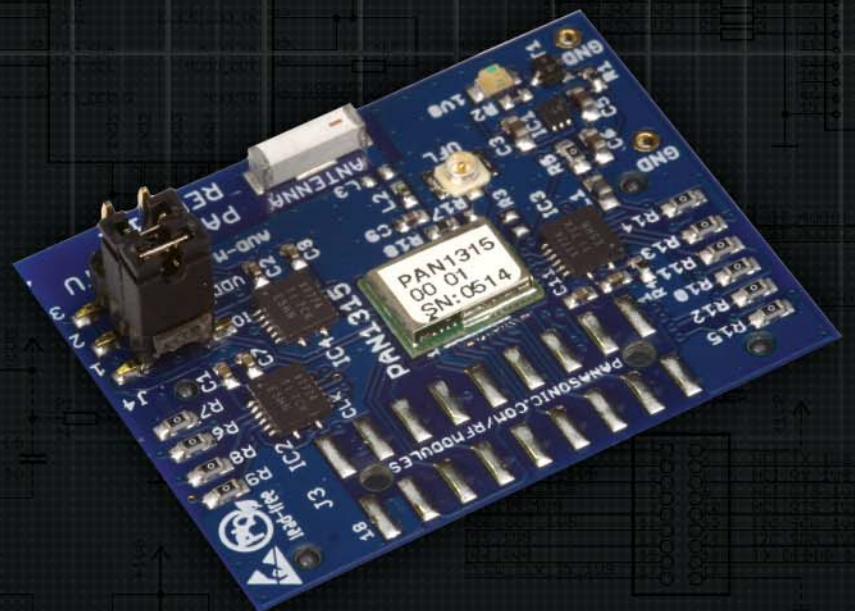

Panasonic's unique Easy-To-Use (ETU) series of modules, plug directly into evaluation kits with the added benefit of header connectors that simplify prototype wiring and field trials.

The engine of the PAN1315ETU is Panasonic's new PAN1315 Host Controlled Interface (HCI) Bluetooth RF module based upon Texas Instrument's seventh generation Bluetooth core integrated circuit, the CC2560.

The PAN1315 series has been designed to be 100% pin compatible with the next generation of Bluetooth Low Energy devices. This unique design feature enables designers to seamlessly transition between Bluetooth Classic and Low Energy modules.

TABLE OF CONTENTS

1.	Scope of this Document	3
2.	Key Features	3
3.	PAN1315 Applications	4
4.	Module Description	4
5.	Detailed Description	5
5.1.	Block Diagram / Design Help	5
5.2.	Schematic	6
5.3.	Placement	7
5.4.	Pin Description	7
5.5.	Clock Inputs	8
6.	Key Parts List	8
7.	Module DimensionS	8
8.	APPLICATION Development	9
8.1.	NEEDED Tools	9
9.	RoHS Declaration	10
10.	Data Sheet Status	10
11.	History for this Document	11
12.	Related Documents	11
13.	General Information	12
14.	FCC Warning	12
15.	Life Support Policy	12

1. SCOPE OF THIS DOCUMENT

This Design Guide is intended for use with the Bluetooth development platform PAN1315ETU. (Easy To Use). This guide will help you create a design that can be implemented quickly into your product.

This guide describes the hardware and gives usefull tips. In addition, the software description can be downloaded from TI's website.

Please refer to chapter 8 "Application Development" for a quick overview.

2. KEY FEATURES

- Fast Time to Market
- Easy PCB Layout Using Eagle CAD Files:
- Capable of 2 Layer PCB with 0.2mm Line Width
- Optional EEPROM for Data Configuration
- Optional -40 to +85°C Operating Temperature Range
- MindTree Ethermind Bluetooth Stack with SPP for TI MSP430 Available From TI.
- Other Profiles Available on Request
- FCC, IC and ETSE Compliant
- 100% Compatible with Next Generation PAN1315 Bluetooth Low Energy/Classic Module

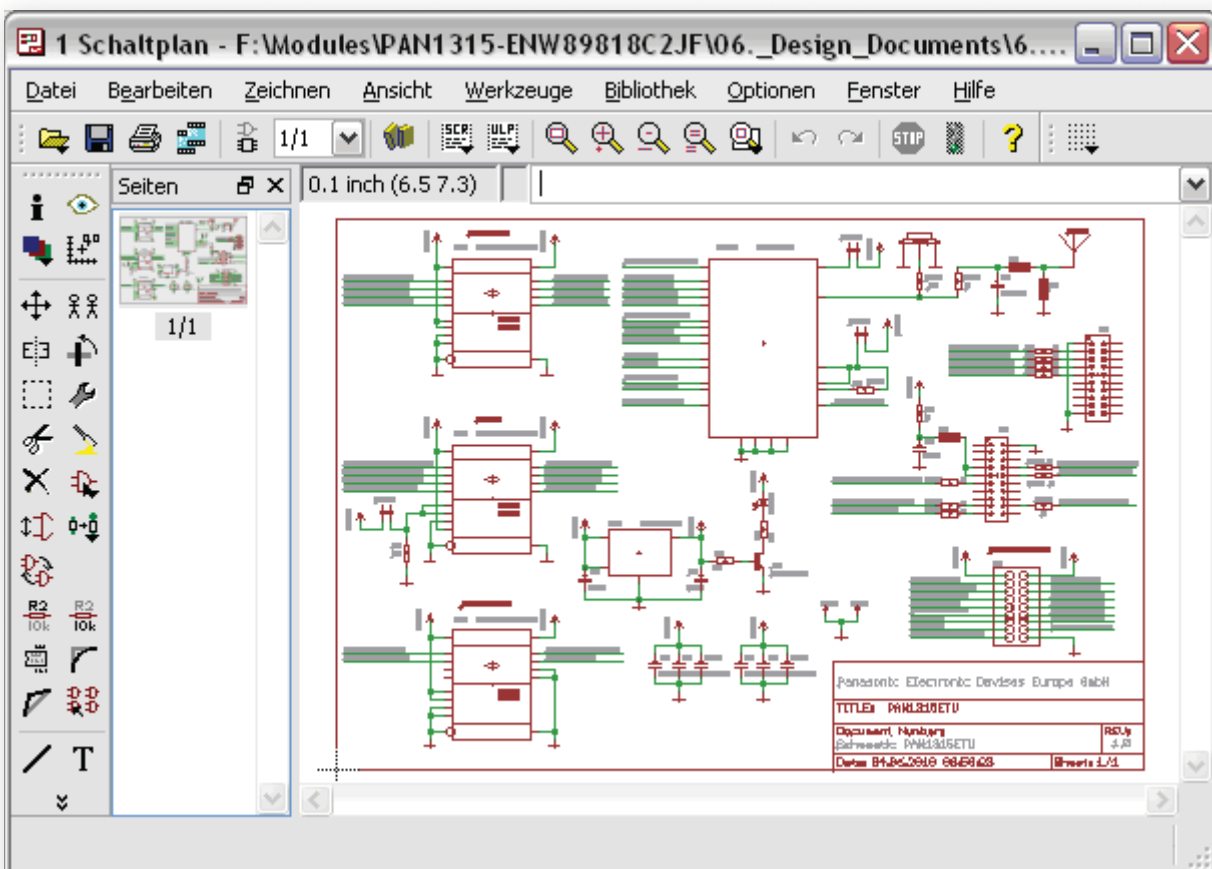

Eagle CAD Files in use

3. PAN1315 APPLICATIONS

All Embedded Wireless Applications

- Access Points
- Printer Adapters
- Printers
- Scanners
- Wireless Sensors
- Low Power
- Cable Replacement
- Personal Digital Assistants (PDAs)
- Access Points
- Computers and Peripherals
- Industrial Control Applications
- Medical

4. MODULE DESCRIPTION

The PAN1315ETU (EasyToUse) Module is a development platform for a class 2 HCI module to implement Bluetooth functionality into various electronic devices.

The PAN1315ETU is intended for evaluation purpose and works with Texas Instrument's MSP430 Hardware Development Kit. Please refer to chapter 8, APPLICATION Development.

Communication between the module and the host controller is typically carried out via UART, but can also be performed through SPI with this hardware.

To aide in the implementation of this reference design, Eagle formatted application and layout files are available on the web at the address below.

www.panasonic.com/industrial/includes/pdf/PAN1315ETU_Eagle_Ver1_1.zip

Please contact your local sales office for further details on additional options and services, by visiting www.panasonic.com/rfmodules.

5. DETAILED DESCRIPTION

5.1. BLOCK DIAGRAM / DESIGN HELP

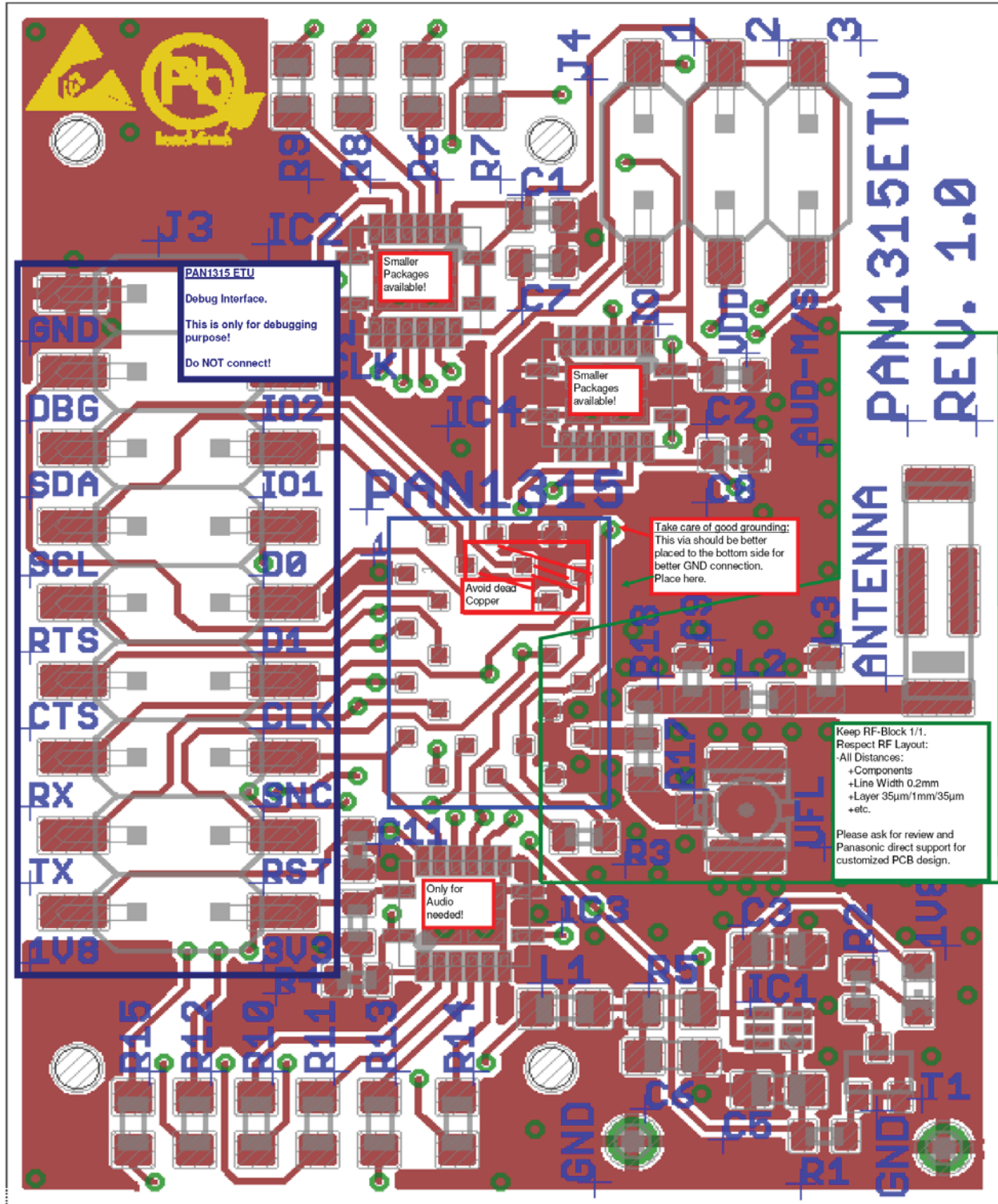

5.2. SCHEMATIC

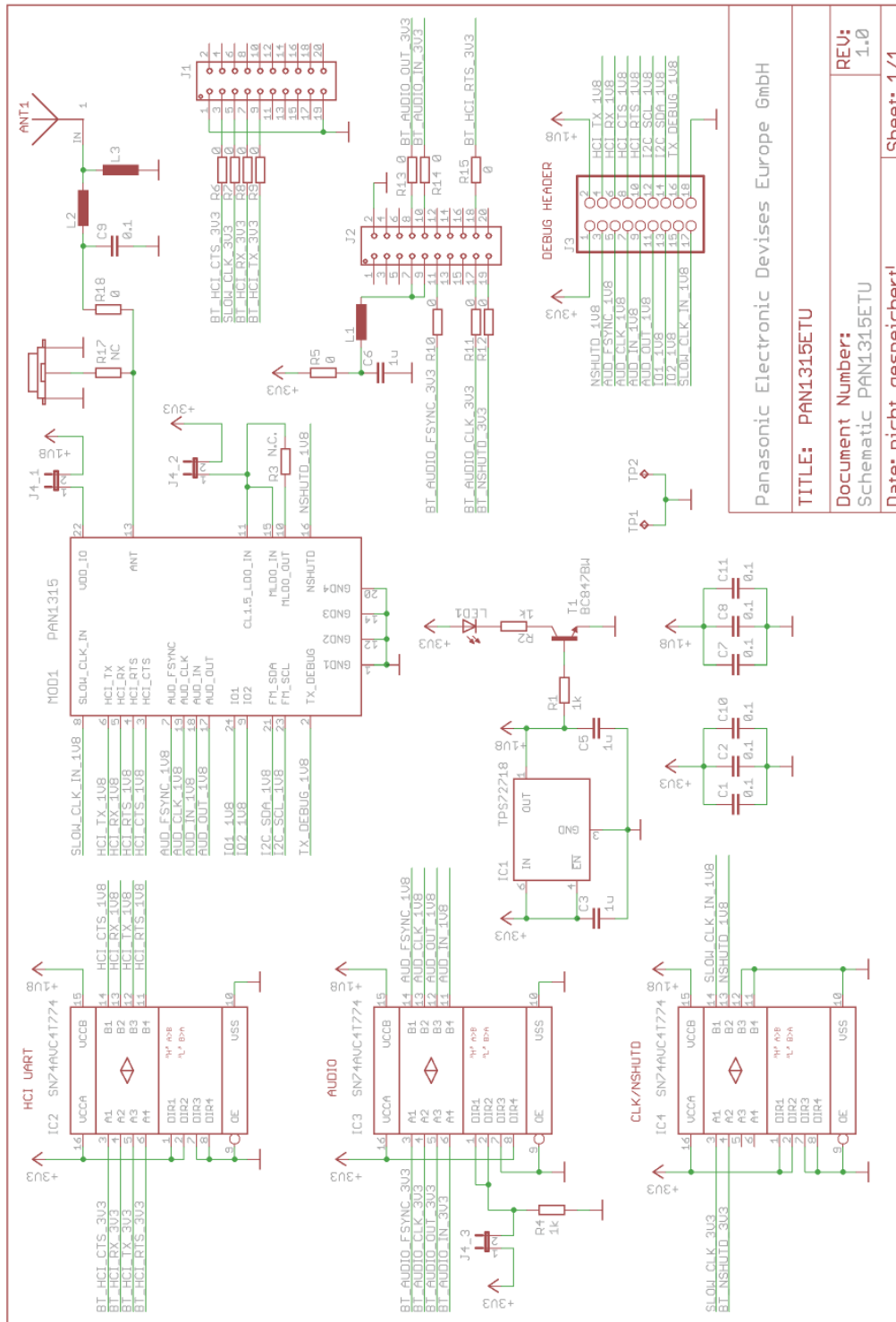

Panasonic Electronic Devises Europe GmbH
TITLE: PAN1315ETU
Document Number: Schematic PAN1315ETU
REV: 1.0
Date: nicht gespeichert!
Sheet: 1/1

Please refer to pages 14 & 15 for a complete parts list.

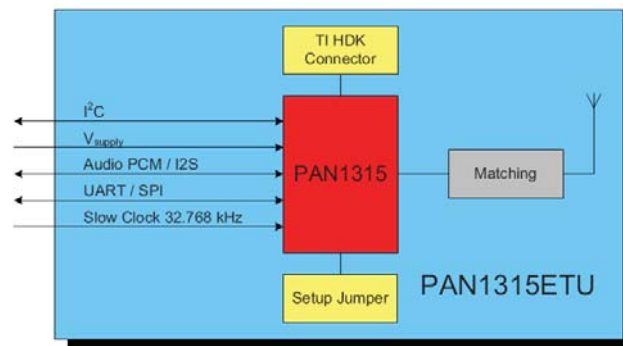

5.3. PLACEMENT

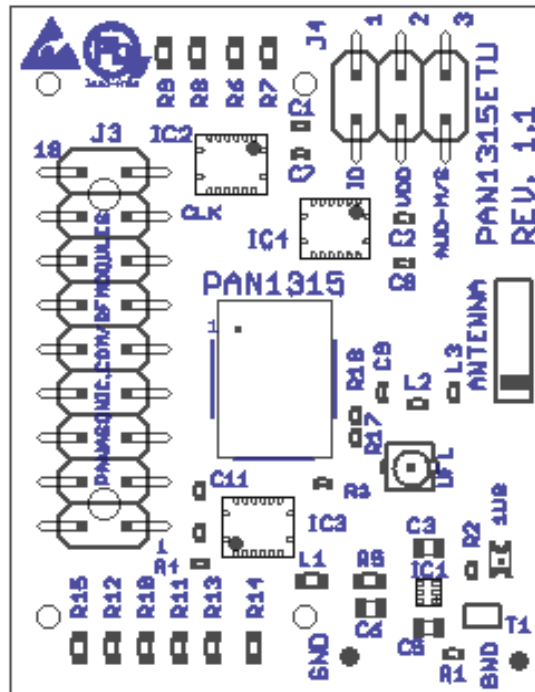

5.4. PIN DESCRIPTION

No	Pin Name	Connector	Def. Dir.1	Description of Options (Common)
1,19	GND	J1		Connect to Ground
3	BT_HCI_CTS_3V3	J1	I	HCI UART clear-to-send
5	SLOW_CLK_3V3	J1	I	HCI
7	BT_HCI_RX_3V3	J1	I	HCI UART data receive
9	BT_HCI_TX_3V3	J1	O	HCI UART data transmit
other	Not connected	J1		
2	GND	J2	I	
7	+3V3	J2	I	
8	BT_AUDIO_OUT_3V3	J2	O	PCM data output
9	+3V3	J2	I	
10	BT_AUDIO_IN_3V3	J2	I	PCM data input
11	BT_AUDIO_FSYNC_3V3	J2	IO	PCM frame synch
17	BT_AUDIO_CLK_3V3	J2	IO	PCM clock
18	BT_HCI_RTS_3V3	J2	O	HCI UART request-to-send
19	BT_NSHUTD_3V3	J2	I	Shutdown input (active low)
other	Not connected	J2		
All	Only for Debug	J3		Do not use
1/2	VDD_IO	J4_1	IO	Used for current measurement
1/2	VDD_LDO/MLDO_IN	J4_2	IO	Used for current measurement
1/2	Audio Direction	J4_3	IO	Audio Direction Set: Direction to PAN1315

I = input; O = output; IO = bidirectional; P = power; PU = pulled up; PD = pulled down

5.5. CLOCK INPUTS

The slow clock is always supplied from an external source. It is connected to the SLOW_CLK_IN and can be a digital signal in the range of 0-1.8 V.

The slow clock's frequency accuracy must be 32.768 kHz \pm 250 ppm for Bluetooth usage (according to the Bluetooth specification).

When the MSP430 Experimenter board is connected the signal is exposed from the μ Controller. So within this application there is no additional clock needed.

6. KEY PARTS LIST

Reference Designator	Partnumber	Supplier
PAN1315	ENW89818C2JF	Panasonic
J1,J2	SFM-110-02-S-D-K-A	Samtec, Farnell
IC1	TPS72718DSET	TI
IC2,3,4	SN74AVC4T774RGYR	TI
J4	Pinheader 2.54mm 6pol	Generic
T1	BC847	Generic
LED1	SMD LED Rot	Generic
ANT1	2450AT43B100	Johanson
UFL2	U.FL	Hirose

7. MODULE DIMENSIONS

No.	Item	Dimension [mm]	Tolerance [mm]	Remark
1	Width	40	\pm 1	
2	Lenght	30	\pm 1	
3	Height	15	\pm 1	With connectors

8. APPLICATION DEVELOPMENT

Mindtree Ltd. has developed Bluetooth software, including a few profiles, for TI's MSP430 and Panasonic's PAN1315. Detailed documentation will be available in the next revision of this document. Also refer to www.panasonic.com/rfmodules

8.1. NEEDED TOOLS

The MSP-EXP430F5438, Experimenter Board can be ordered here:

<http://focus.ti.com/docs/toolsw/folders/print/msp-exp430f5438.html>

The MSP-FET430UIF430, Debugging Interface can be ordered here:

<http://focus.ti.com/docs/toolsw/folders/print/msp-fet430uif.html>

The PAN1315EMK, Bluetooth Evaluation Module Kit for MSP430 can be ordered here:

<http://www.panasonic.com/industrial/electronic-components/rf-modules/bluetooth/pan1315etu.aspx>

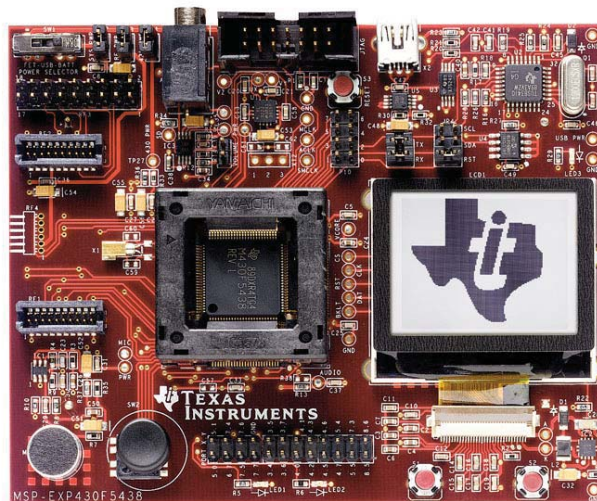

MSP-EXP430F5438
MSP430F5438 Experimenter Board

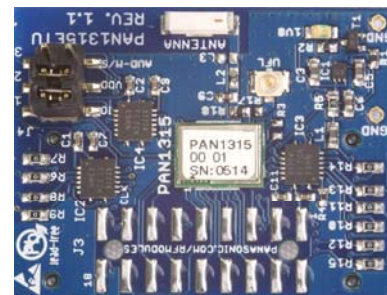

PAN1315ETU

In addition, a software development environment, e.g. IAR Embedded Workbench, is required, please visit www.iar.com

For a detailed description on usage of these tools please refer to:

http://wiki.msp430.com/index.php/MSP430_Bluetooth_Platform

Evaluation kits and modules are available through Panasonic's network of authorized distributors. For additional information visit www.panasonic.com/rfmodules.

9. ROHS DECLARATION

Declaration of environmental compatibility for supplied products:

Panasonic Electronic Devices Europe GMBH hereby declares, to the best of our current knowledge, based on the declaration of our suppliers that this product does not contain the following substances which are banned by Directive 2002/95/EC (RoHS) or if contain a maximum concentration of 0.1% by weight in homogeneous materials:

- Lead and lead compounds
- Mercury and mercury compounds
- Chromium (VI)
- PBB (polybrominated biphenyl) category
- PBDE (polybrominated biphenyl ether) category

And a maximum concentration of 0.01% by weight in homogeneous materials for

- Cadmium and cadmium compounds

10. DATA SHEET STATUS

This data sheet contains preliminary product specification. Panasonic reserves the right to change the specification without notice, in order to improve the design and supply the best possible product.

Preliminary product specification means also that the hardware has the engineering sample (ES) status.

Please consult the most recently issued data sheet before initiating or completing a design.

11. HISTORY FOR THIS DOCUMENT

Revision Version	Date Datum	Modification / Remarks Änderungen / Bemerkungen
0.90	24.02.2010	1 st preliminary version
0.95	13.03.2010	Accept all changes from RT and added the FCC warning. Correct some formats and create a new directory
0.96	09.06.2010	Included Design Guide, BOM

12. RELATED DOCUMENTS

For an update, please visit the following website:

IAR Embedded Workbench Version 3+ for MSP430 User's Guide
Rev. Q, 25 Nov 2009

<http://www.ti.com/lit/pdf/slau138>

PAN1315 Datasheet:

<http://www.panasonic.com/industrial/electronic-components/rf-modules/bluetooth/pan1315.aspx>

13. GENERAL INFORMATION

© Panasonic Electronic Devices Europe GmbH 2010.

All rights reserved.

This product description does not lodge the claim to be complete and free of mistakes.

Please contact the related product manager in every case.

Any ES samples delivered to the customer have the status Engineering Samples. This means, the design of this product is not yet concluded. Engineering Samples may be partially or fully functional, and there may be differences that will be published in the most recent Data Sheet.

Engineering Samples are not qualified and are not to be used for reliability testing or series production.

Disclaimer:

Customer acknowledges that samples may deviate from the Data Sheet and may bear defects due to their status of development and the lack of qualification mentioned above.

Panasonic rejects any liability or product warranty for Engineering Samples. In particular, Panasonic disclaims liability for damages caused by

- The use of the Engineering Sample other than for Evaluation Purposes, particularly the installation or integration in an other product to be sold by Customer,
- Deviation or lapse in function of Engineering Sample,
- Improper use of Engineering Samples.

Panasonic disclaims any liability for consequential and incidental damages.

In case of any questions, please contact your local sales partner or the related product manager.

14. FCC WARNING

This equipment is intended for use in a laboratory test environment only. It generates, uses, and can radiate radio frequency energy and has not been tested for compliance with the limits of computing devices pursuant to subpart J of part 15 of FCC rules, which are designed to provide reasonable protection against radio frequency interference. Operation of this equipment in other environments may cause interference with radio communications, in which case the user at his own expense will be required to take whatever measures may be required to correct this interference.

15. LIFE SUPPORT POLICY

This Panasonic product is not designed for use in life support appliances, devices, or systems where malfunction can reasonably be expected to result in a significant personal injury to the user, or as a critical component in any life support device or system whose failure to perform can be reasonably expected to cause the failure of the life support device or system, or to affect its safety or effectiveness. Panasonic customers using or selling these products for use in such applications do so at their own risk and agree to fully indemnify Panasonic for any damages resulting.

APPENDIX:

Test Procedure:

The PAN1315ETU is connected via the MSP430 Board, HCI UART to PC. The connection to CBT is made via the ETU's Antenna to the CBT reference antenna. Output power and current consumption is then checked.

PARTS LIST: (Please refer to the schematic on page 6)

	Part	Value	Device	Package	Comments
Antenna	ANT1	JOH_2450AT43B100 JOH_2450AT43B100	SMD_7X2X2	Antenna	1
Capacitors	C1	0.1	C-EUC0402	C0402	rcl
	C2	0.1	C-EUC0402	C0402	rcl
	C3	1u	C-EUC0603	C0603	rcl
	C5	1u	C-EUC0603	C0603	rcl
	C6	1u	C-EUC0603	C0603	rcl
	C7	0.1	C-EUC0402	C0402	rcl
	C8	0.1	C-EUC0402	C0402	rcl
	C9	2.2 pF	C-EUC0402	C0402	rcl
	C10	0.1	C-EUC0402	C0402	rcl
	C11	0.1	C-EUC0402	C0402	rcl
	Integrated Circuits	IC1	TPS72718	TPS72718	DSE_S-PDS0-N6 texas
IC2		SN74AVC4T774	SN74AVC-4T774RGY	RGY	SN74AVC4T774 1
IC3		SN74AVC4T774	SN74AVC-4T774RGY	RGY	SN74AVC4T774 1
IC4		SN74AVC4T774	SN74AVC-4T774RGY	RGY	SN74AVC4T774 1
Connectors	J1	SFM-110-02-SM-D-A-K- TRSFM-110-02_2 SFM- 110-02_2 Samtec	1		
	J2	SFM-110-02-SM-D-A-K- TRSFM-110-02_2 SFM- 110-02_2 Samtec	1		
	J3	NC	_PINHD- 2X9SMD	_2X09SMD	pinhead
	J4_1	_PINHD-2X1SMD	_2X1SMD	pinhead	1
	J4_2	_PINHD-2X1SMD	_2X1SMD	pinhead	1
	J4_3	_PINHD-2X1SMD	_2X1SMD	pinhead	1
	UFL2	U.FL	U.FL	U.FL	hirose

	Part	Value	Device	Package	Comments
Inductors	L1	1K Ω , 100mA	L0603	rcl	1
	L2	3.6 nH	L0402	rcl	1
	L3	Not Mounted	L0402	rcl	1
LED	LED1	LEDCHIPLED_0805	CHI- PLED_0805 led	1	
RF Module	MOD1	PAN1315P1315FP_! PAN1315P1315FP_!	P1315FP_1	P1315_Eagle4 1	
Resistors	R1	1k	R-EU_R0402	R0402	rcl
	R2	1k	R-EU_R0402	R0402	rcl
	R3	N.C.	R-EU_R0402	R0402	rcl
	R4	1k	R-EU_R0402	R0402	rcl
	R5	0	R-EU_R0603	R0603	rcl
	R6	0	R-EU_R0603	R0603	rcl
	R7	0	R-EU_R0603	R0603	rcl
	R8	0	R-EU_R0603	R0603	rcl
	R9	0	R-EU_R0603	R0603	rcl
	R10	0	R-EU_R0603	R0603	rcl
	R11	0	R-EU_R0603	R0603	rcl
	R12	0	R-EU_R0603	R0603	rcl
	R13	0	R-EU_R0603	R0603	rcl
	R14	0	R-EU_R0603	R0603	rcl
	R15	0	R-EU_R0603	R0603	rcl
	R17	NC	R-EU_R0402	R0402	rcl
	R18	0	R-EU_R0402	R0402	rcl
	Other	T1	BC847BW	BC847BW	SOT323
TP1		TPP1-10	TPP1-10	_P1-10	testpad
TP2		TPP1-10	TPP1-10	_P1-10	testpad