



## GP-10HCN1L/H

- Centrifugal type
- Capacity = 10 L/min - 99 L/min
- Total head = 25m - 34m
- Stainless steel (SUS 304) impeller
- Cast iron casing with double paint coated housing
- SUS 304 steel motor shaft
- Insulation class: F
- IEC Standard compliance

### Dimension

Unit : mm

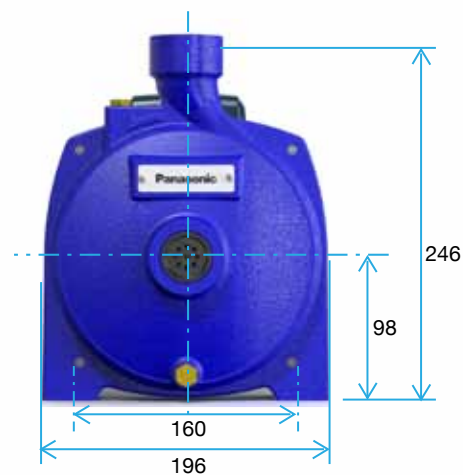
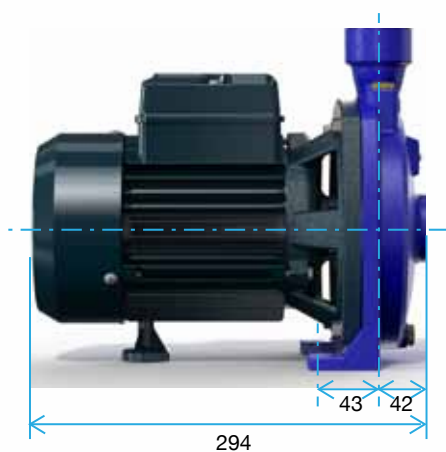

### Specification

	GP-10HCN1L/H
Rated Voltage	220V - 240V 50Hz, single phase
Capacity [L/min]	10 - 99
Total Head [m]	25 - 34
Input Wattage [kW]	1.16
Output Wattage [kW]	0.75 (1.0 HP)
Ampere [A]	5.15
IP Rating	IP54
Suction Pipe	1 inch (25 mm)
Discharge Pipe	1 inch (25 mm)
Size (L x W x H) [mm]	294 x 196 x 246
Weight [kg]	12

