

Panasonic®

Operating Instructions and Cookbook Convection/Grill Microwave Oven

For domestic use only



Model No. NN-CT651M

Before operating this oven, please read these instructions carefully and keep for future reference.

Contents

Installation and Connection	2
Warning	3
Safely Instructions	4
Important Information	5
Outline Diagram	6
Control Panel	7
Setting the Clock/Child Safety Lock	8
Microwave Cooking and Defrosting/Timer	9
Defrosting Guidelines	10
Grilling	11
Combination Cooking	12
Convection Cooking	13
Auto Defrost	14
Pointers to successful use of Auto Menus	15
Auto Menu	
Reheat Menu	16
Main Dish	17-24
Side Dish (Gravy)	25-32
Side Dish (Dry)	33-38
Soup/Snack	39-47
Tandoori/Grill	48-54
Japanese	55-58
Dessert	59-63
Cake/Cookie	64-68
Questions and Answers	69
Care of Your Oven	70
Technical Specifications	71

Installation and Connection

Examine your microwave oven

Unpack the oven, remove all packing material, and examine the oven for any damage such as dents, broken door latches or cracks in the door. If you find any damage, notify your dealer immediately. Do not install a damaged microwave oven.

Earthing instructions

IMPORTANT: THIS UNIT HAS TO BE PROPERLY EARTHED FOR PERSONAL SAFETY.

If your AC outlet is not grounded, it is the personal responsibility of the customer to have it replaced with a properly grounded wall socket.

Operation voltage

The voltage has to be the same as specified on the label on the oven. If a higher voltage than specified is used, it may cause a fire or other damages.

Placement of the Oven

1. This oven is intended for Household counter top use only. It is not intended for built-in use or for use inside a cupboard. Place the oven on a flat and stable surface more than 85 cm above the floor.
2. When this oven is installed, it should be easy to isolate the appliance from the electricity supply by pulling out the plug or operating a circuit breaker.
3. For proper operation, ensure a sufficient air circulation for the oven.

Counter-top use:

- a. Allow 15 cm of space on the top of the oven, 10 cm at the back, 5 cm on one side, and the other side must be opened.
- b. If one side of the oven is placed flush to a wall, the other side or top must not be blocked.

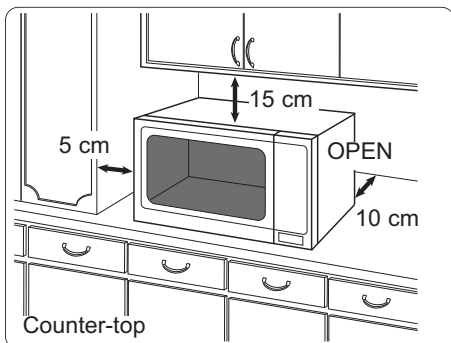

4. Do not place this oven near an electric or gas cooker range.
5. The feet should not be removed.
6. This oven is only for household usage. Do not use outdoors.
7. Avoid using the microwave oven in high humidity.
8. The power cord should not touch the outside of the oven. Keep the cord away from hot surfaces. Do not let the cord hang over the edge of a table or work top. Do not immerse the cord, plug or oven in water.
9. Do not block the air vents on the left side and back of the oven. If these openings are blocked during operation the oven may overheat. In this case the oven is protected by a thermal safety device and resumes operation only after cooling down.
10. This appliance is not intended to be operated by means of an external timer or separate remote control system.

Warning

Important Safety Instructions

1. The door seals and seal areas should be cleaned with a damp cloth.
The appliance should be inspected for damage to the door seals and door seal areas and if these areas are damaged the appliance should not be operated until it has been repaired by a service technician trained by the manufacturer.
2. Do not attempt to tamper with or make any adjustments or repairs to the door, control panel housing, safety interlock switches or any other part of the oven. Do not remove the outer panel from the oven which gives protection against exposure to microwave energy.
Repairs should only be done by a qualified service person.
3. Do not operate this appliance if it has a damaged CORD OR PLUG, if it is not working properly, or if it has been damaged or dropped. It is dangerous for anyone other than a service technician trained by the manufacturer to perform repair service.
4. If the supply cord is damaged, it must be replaced by the manufacturer or its service agent or a similarly qualified person in order to avoid a hazard.
5. Only allow children to use the oven without supervision when adequate instructions have been given so that the child is able to use the oven in a safe way and understands the hazards of improper use.
6. Liquids and other foods must not be heated in sealed containers since they are liable to explode.
7. This appliance is not intended for use by persons (including children) with reduced physical, sensory or capabilities, or lack of experience and knowledge unless they have been given responsible for their safety. Children should be supervised to ensure that they do not play with the appliance.
8. DO NOT attempt to touch heating device on top and back of inside cavity while cavity is hot.
Heating device may be still hot.
9. The surfaces are liable to get hot during use.
10. This appliance is intended to be used in household and similar applications such as:
 - stuff kitchen areas in shops, offices and other working environments;
 - farm houses;
 - by clients in hotels, motels and other residential type environments;
 - bed and breakfast type environments.

Safety Instructions

Use of your oven

1. Do not use the oven for any reason other than the preparation of food. This oven is specifically designed to heat or cook food. Do not use this oven to heat chemicals or other non-food products.
2. Before use, check that utensils/containers are suitable for use in microwave ovens.
3. Do not attempt to use this microwave oven to dry newspaper, clothing or any other materials. They may catch on fire.
4. When the oven is not being used, do not store any objects other than oven accessories inside the oven in case it is accidentally turned on.
5. The appliance shall not be operated by MICROWAVE, GRILLING, CONVECTION or COMBINATION WITHOUT FOOD IN THE OVEN.
Operation in this manner may damage the appliance.
6. If smoke or a fire occurs in the oven, press the STOP/RESET Pad and leave door closed. Disconnect the power cord, or shut off power at fuse or circuit breaker panel.

Heater Operation

1. Exterior oven surfaces, including air vents on the cabinet and the oven door will get hot during GRILLING, CONVECTION and COMBINATION, take care when opening or closing the door and when inserting or removing food and accessories.
2. The oven has two heaters situated in the top of the oven. After using the GRILL, CONVECTION and COMBINATION function, these surfaces will be very hot. Care should be taken to avoid touching the heating elements inside the oven.
N.B.: After cooking by these modes, the oven accessories will be very hot.
3. The accessible parts may become hot when the grill is in use. Children should be kept away.
4. When the appliance is operated in the combination mode, children should only use the oven under adult supervision due to the temperatures generated.

Oven Light

When it becomes necessary to replace the oven light, please consult your dealer.

Accessories

The oven comes equipped with a variety of accessories. Always follow the directions given for use of the accessories.

Roller Ring

1. The roller ring and the oven floor should be cleaned frequently to prevent noise and build-up of remaining food.
2. The roller ring must always be used for cooking together with the ceramic tray.

Wire Rack

1. The Wire Rack is used to facilitate browning of small dishes and help with the good circulation of the heat.
2. Do not use any metal container directly on the Wire Rack in COMBINATION with MICROWAVE.
3. Do not use the Wire Rack in MICROWAVE mode only.

Important Information

1) Cooking Times

The cooking time depends on the condition, temperature, amount of food and on the type of cookware.

Begin with the minimum cooking time to help prevent overcooking. If the food is not sufficiently cooked you can always cook it for a little longer.

N.B.: If the recommended cooking times are exceeded the food will be spoiled and in extreme circumstances could catch fire and possibly damage the interior of the oven.

2) Small Quantities of Foods

Small quantities of food or foods with low moisture content can burn, dry out or catch on fire if cooked too long. If materials inside the oven should ignite, keep the oven door closed, turn the oven off and remove the plug from the socket.

3) Eggs

Do not cook eggs in their shells and whole hard-boiled eggs by MICROWAVE.

Pressure may build up and the eggs may explode, even after the microwave heating has ended.

4) Piercing Skin

Food with non porous skins, such as potatoes, egg yolks and sausages must be pierced before cooking by MICROWAVE to prevent bursting.

5) Meat Thermometer

Use a meat thermometer to check the degree of cooking of roasts and poultry only when the meat has been removed from the oven. Do not use a conventional meat thermometer in the microwave oven because it may cause sparking.

6) Liquids

When heating liquids, e.g. soup, sauces and beverages in your microwave oven, overheating the liquid beyond boiling point can occur without evidence of bubbling. This could result in a sudden boil over of the hot liquid.

To prevent this possibility the following steps should be taken:

- a) Avoid using straight-sided containers with narrow necks.
- b) Do not overheat.
- c) Stir the liquid before placing the container in the oven and again halfway through the cooking time.
- d) After heating, allow it to stand in the oven for a short time, stir again before carefully removing the container.

7) Paper/Plastic

When heating food in plastic or paper containers, check the oven frequently as these types of containers ignite if overheated.

Do not use recycled paper products (e.g. Kitchen Roll) unless the paper product is labelled as safe for microwave oven use.

Recycled paper products may contain impurities which may cause sparks and/or fires during use.

Remove wire twist-ties from roasting bags before placing the bags in the oven.

8) Utensils/Foil

Do not heat any closed cans or bottles because they might explode.

Metal containers or dishes with metallic trim should not be used during microwave cooking. Sparking will occur.

If you use any aluminium foil, meat spikes or metalware the distance between them and the oven walls and door should be at least 2 cm to prevent sparking.

9) Feeding Bottles/Baby Food Jars

The top and teat or lid must be removed from feeding bottles or baby food jars before placing in the oven.

The contents of feeding bottles and baby food jars are to be stirred or shaken.

The temperature has to be checked before consumption to avoid burns.

Outline Diagram

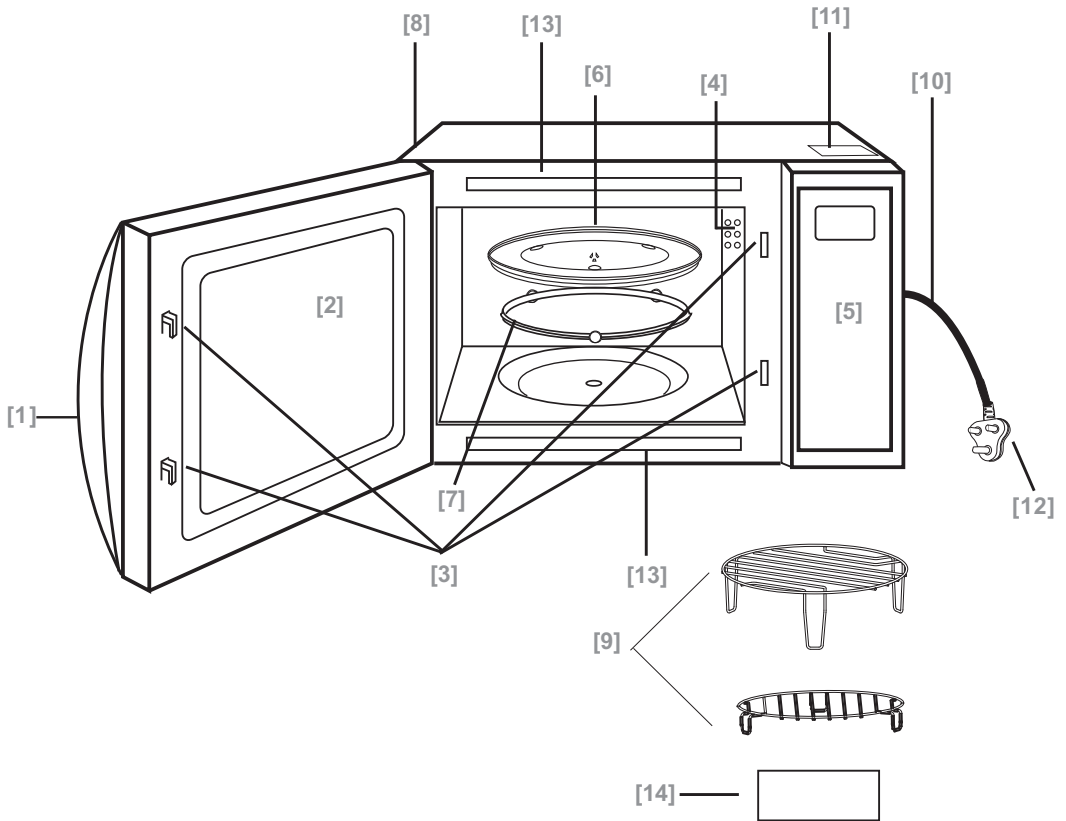

[1] Door Opening Handle

Pull to open the door. When you open the oven door during cooking, the cooking is stopped temporarily without clearing earlier made settings. Cooking resumes as soon as the door is closed and Start is pressed.

[2] Oven Window

[3] Door Safety Lock System

[4] Oven Air Vent

[5] Control Panel

[6] Glass Tray

[7] Roller Ring

[8] External Oven Air Vents (Not shown)

[9] Wire Rack (High/Low)

[10] Power Cord

[11] Caution Label (Hot surfaces)

[12] Power Plug

[13] Menu Labels

[14] Menu Sheet

Control Panel

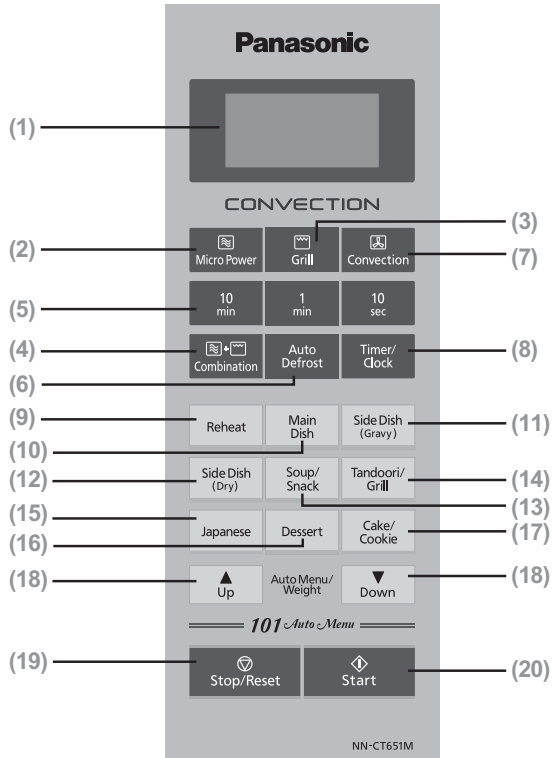

- (1) Display Window
- (2) Microwave Power Levels
- (3) Grill Pad
- (4) Combination
- (5) Time Pads (10 min/1 min/10 sec)
- (6) Auto Defrost Programs
- (7) Convection Pad
- (8) Timer/Clock Pad
- (9) Reheat Programs
- (10) Auto Programs (Main Dish)
- (11) Auto Programs (Side Dish/Gravy)
- (12) Auto Programs (Side Dish/Dry)
- (13) Auto Programs (Soup/Snack)
- (14) Auto Programs (Tandoori/Grill)
- (15) Auto Programs (Japanese)
- (16) Auto Programs (Dessert)
- (17) Auto Programs (Cake/Cookie)
- (18) Up/Down for choosing menu or weight setting
- (19) Stop/Reset Pad:

Before Cooking:

One press clears your instructions.

During Cooking:

One press temporarily stops the cooking program. Another press cancels all your instructions and the time of day will appear in the display.

- (20) Start Pad

Setting the Clock

When the oven is first plugged in “88.88” appears in display window.

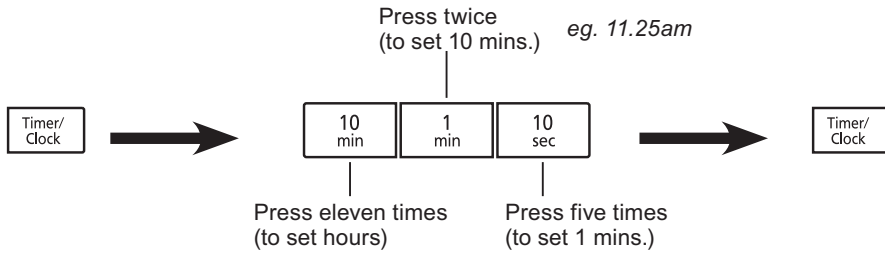

- **Keep pressing Timer/Clock Pad until 24H appears. Continue press this pad again to select 12H.**

- **Press Time Pads** - Enter time of day by pressing appropriate Time pads (refer to point 3 below).

- **Press Clock Pad once.** Time of day is now locked into the display.

N.B.

1. To reset time of day, repeat step 1 through to step 3.
2. The Clock will keep the time of day as long as the oven is plugged in and electricity is supplied.
3. When setting the clock, the 10 min pad works as the hour pad, the 1 min pad works as the 10 min pad and the 10 sec pad works as the 1 min pad.

Child Safety Lock

Using this system will make the oven controls inoperable; however, the door can be opened. Child Lock can be set when the display shows a colon or the time.

To Set:



To Cancel:



- **Press Start Pad three times in 10 seconds.** '🔒' is indicated in the display.

- **Press Stop/Reset Pad three times in 10 seconds.** '🔒' disappears in the display.

Microwave Cooking and Defrosting

The glass tray must always be in position when using the oven.

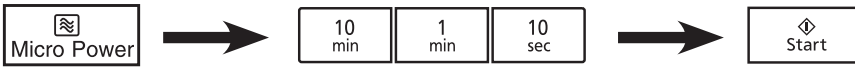

		Level	Wattage
1 Press	<i>Max</i>	P100	900 Watts
2 Presses	<i>Medium</i>	P80	715 Watts
3 Presses	<i>Low</i>	P50	440 Watts
4 Presses	<i>Defrost</i> **	P30	250 Watts
5 Presses	<i>Warm</i>	P10	100 Watts

- **Press the microwave power pad.** Select desired power level - The microwave indicator lights and the level (P100, P80, P50, P30 or P10) appears in the display.

- **Select cooking time by pressing appropriate pads.** Your oven can be programmed for 99 minutes 50 seconds in Medium, Low, Warm and Defrost power. Max power can be programmed for 30 minutes.

- **Press Start.** The cooking program will start and the time in the display will count down.

CAUTION: The oven will automatically work on MAX microwave power if a cooking time is entered without the power level previously being selected.

Multi-Stage Cooking

The oven has 3 stage cooking, so you can program up to 2 different instructions and the oven will switch automatically from power to power (Repeat steps 1 and 2 above but only press Start after both stages have been entered).

N.B.

Auto Menu or Auto Defrost cannot be programmed.

Timer

This feature operates as a minute timer. During operation there is no microwave energy.

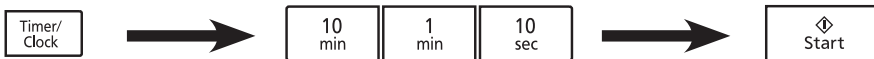

- **Press the Timer/Clock Pad once.** Nothing appears in the display window.

- **Set desired time.** Maximum time is 99 minutes 50 seconds.

- **Press Start.** The time in the display will count down.

Defrosting Guidelines

Tips for Defrosting

Check the defrosting several times, even if you use the auto programs. Observe the standing times.

STANDING TIMES

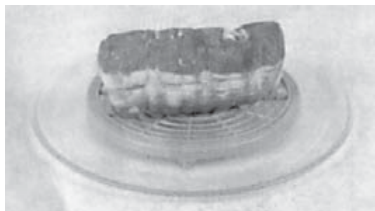

Individual portions of food may be cooked almost immediately after defrosting. It is normal for large portions of food to be frozen in the centre. Before cooking, allow to stand for a **minimum of one hour**. During this standing time, the temperature becomes evenly distributed and the food is defrosted by conduction. **N.B.** If the food is not going to be cooked immediately, store it in the refrigerator. Never refreeze defrosted food without first cooking it.

CHICKEN PIECES



Chops and chicken pieces must be separated as soon as possible so that they defrost evenly throughout. Fatty parts and the ends defrost more quickly. Place them near the centre of the turntable or protect them.

WHOLE CHICKEN



It is preferable to place the joints on an upturned plate or plastic rack so that they are not resting in the juices. It is essential to protect delicate or projecting parts of this food with small pieces of foil to prevent these parts from cooking. It is not dangerous to use small pieces of foil in your oven, provided **they do not come into contact with the oven walls**.

FISH, MUTTON AND VEGETABLES

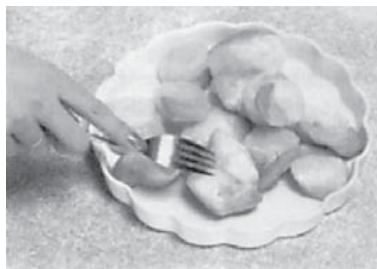

Since the outside of these foods quickly defrosts, it is necessary to separate them, break the blocks into pieces frequently while defrosting and remove them when they have defrosted.

Grilling

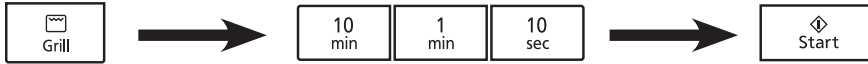

- **Press Grill pad to select level.**

- 1 press grill 1 (high)
- 2 presses grill 2 (low)

The grill indicator lights and grill level (G-1 or G-2) appears in the display.

Press	Level	Grill
1 press	G-1	1400 W
2 presses	G-2	970 W

- **Select Cooking time.**

Time can be set up to 99 minutes 50 seconds.

- **Press Start** - The time counts down in the display.

N.B.

1. Place food on wire rack on turntable. Place a heatproof plate (Pyrex®) underneath to catch fat and drips.
2. Never cover foods when grilling.
3. DO NOT attempt to preheat the grill.
4. The grill will only operate with the oven door closed. It is not possible to use the grill function with the door open.
5. There is no microwave power on the GRILL only program.
6. Most foods require turning halfway during cooking. When turning food, open oven door and CAREFULLY remove wire rack using oven gloves.
7. After turning, return food to the oven and close door. After closing oven door, press START. The oven display will continue to count down the remaining grilling time. It is quite safe to open the oven door at any time to check the progress of the food as it is grilling.
8. The grill will glow on and off during cooking - this is normal. Always clean the oven after using the Grill and before using the microwave or combination.
9. DO NOT attempt to touch heating device on top and back of inside cavity while cavity is hot. Heating device may be still hot.

CAUTION: The wire rack must always be used with the glass tray in position. Remove wire rack from oven by holding the rack and heatproof dish firmly. Use oven gloves when removing accessories. Never touch the outside window or inside metal parts of the door or oven when taking food in or out due to the high temperatures involved.

Combination Cooking

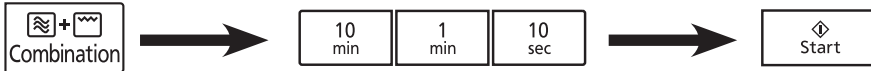

- **Press combination pad to select level.** The microwave and grill indicator lights and combination level (C-1, C-2, C-3, C-4, C-5 or C-6) appears in the display.
- **Select cooking time.** Time can be set up to 99 minutes 50 seconds.
- **Press Start.**

Press	Display	Level	MW	Grill	Convection
1 press	C-1	Combi 1	450 W	700 W	-
2 presses	C-2	Combi 2	250 W	1000 W	720 W
3 presses	C-3	Combi 3	250 W	480 W	720 W
4 presses	C-4	Combi 4	450 W	700 W	500 W
5 presses	C-5	Combi 5	250 W	1000 W	-
6 presses	C-6	Combi 6	-	1000 W	1400 W

When cooking by combination, the microwave power cooks food quickly whilst the grill gives traditional browning and crisping.

N.B.

1. The wire racks are designed to be used for **Combination**, Grilling and convection. Never attempt to use any other metal accessory except the one provided with the oven. Place a heatproof dish underneath to catch any fat or drips.
2. Use the wire rack only as described. DO NOT use if operating the oven with less than 0.2 kg of food on a manual program. For small quantities do not cook by **combination**, cook by GRILL, convection or MICROWAVE ONLY for best results.
3. Never cover foods when cooking on **combination**.
4. DO NOT preheat the grill on **combination**.
5. Arcing may occur if the incorrect weight of food is used, the wire rack has been damaged, or a metal container has been used accidentally. Arcing is flashes of blue light seen in the microwave. If this occurs, stop the oven immediately.
6. Some foods should be cooked on **combination** without using the wire rack i.e. roasts, gratins, pies and puddings. The food should be placed in a heatproof non-metallic dish and placed directly onto the turntable.
7. DO NOT use plastic MICROWAVE containers on combination programs (unless suitable for combination cooking.) Dishes must be able to withstand the heat of the top grill - heatproof glass e.g. Pyrex® or ceramic are ideal.
8. DO NOT use your own metal dishes or tins, as the microwaves will not penetrate the food evenly.

CAUTION: The wire rack must always be used with the glass tray in position. Remove grill rack from oven by holding the rack and heatproof dish firmly. Use oven gloves when removing accessories. Never touch the outside window or inside metal parts of the door or oven when taking food in or out due to the high temperatures involved.

Convection Cooking

A. Convection Cooking without preheating

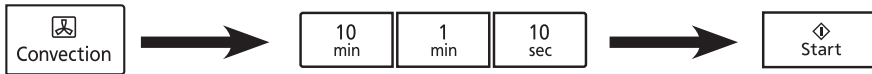

- **Press convection pad to select convection temperature.**

The convection indicator lights and the temperature (180, 190,..., 200, 100 °C,...) appears in the display.

- **Select cooking time.**

Time can be set up to 99 minutes 50 seconds.

- **Press Start.**

B. Convection Cooking with preheating



- **Press convection pad to select convection temperature.**

The convection indicator lights and the temperature (180, 190,..., 200, 100 °C,...) appears in the display.

- **Press Start to start preheating.**

- **Select cooking time.**

Time can be set up to 99 minutes 50 seconds.

- **Press Start.**

N.B.

1. During the convection preheating state, if the preheating temperature arrives, the buzzer will sound 3 times to remind you to put the food into the oven. And the preheated temperature is displayed and flash. Then open the oven door, and put the food into the oven and close the door.
2. Cooking time cannot be input until the preheating temperature arrives. If the temperature arrives, door must be opened to input the cooking time.
3. If the time not input in 10 minutes, the oven will stop preheating. The buzzer sounds five times and turn back to waiting states.

Auto Defrost

With this feature you can defrost frozen food according to the weight.



- **Select the desired Auto Defrost Program**
 - 1 Press 1 Chicken pieces
 - 2 Presses 2 Whole chicken
 - 3 Presses 3 Fish
 - 4 Presses 4 Mutton
 - 5 Presses 5 Vegetables
- **Set Weight. Adjust the weight by using the Up or Down pads.** And the kg indicator lights.
- **Press Start.**

Auto Program number appears in the display. The auto and defrost indicators light.

Display	Program	Min./Max. Weight
d-1	1 Chicken Pieces	0.2-1.5 kg
d-2	2 Whole chicken	1-1.5 kg
d-3	3 Fish	0.2-1.5 kg
d-4	4 Mutton	0.2-1.5 kg
d-5	5 Vegetables	0.1-1 kg

Pointers to successful use of Auto Menus

Pointers to successful use of Auto Menus

These menus are developed to make the best use of your MWO for Indian cooking. The recipes are simplified to suit the modern life style. They are easy to follow and can be attempted even by the beginners, by carefully following the instructions. Please read these pointers to get the best results.

All ingredients should be at room temperature.

Standard measuring cups and spoons must be used.

1 cup = 250 ml

1 Tbsp = 15 ml

1 tsp = 5 ml

While it is necessary to measure the main ingredients accurately, varying the seasoning as per taste will not affect the performance of the auto menus.

Use good quality ingredients and tender vegetables.

Use the recommended size of containers.

Read the recipe carefully and measure and prepare all the ingredients according to the instructions, before starting to cook.

Many recipes have two stages of cooking and a beep between them.

The beep time is mentioned in the instructions. Be ready to open the door of the MWO immediately after the beep. If you miss the beep, the ingredients in the first stage will continue to cook and if you add the 2nd stage ingredients later than beep stage, they may not cook well. Protect your hands with oven mittens or cotton towel while handling the hot dishes.

Once you have opened the MWO door after the beep, you have 6 minutes to add the 2nd stage ingredients as in the instructions, until start key is pressed. Therefore there is no need to rush with the next step. Carefully take out the dish, add the next set of ingredients. (which should be kept ready before starting the cooking) Mix well and continue with the cooking. This can be done at a comfortable pace.

However, avoid needless delay.

Recipes marked (H) indicate that they are healthy and low calorie.

Some of auto menus are recommended to use a flat aluminum/stainless steel plate by customer for better performance. Please prepare it prior to cooking.

Auto Menu

[1] Reheat Menu



- **Select desired category.**
The auto indicator lights and the program number 1-1 appears in the display.
- **Press Up/Down pad to select the suitable number in below chart.**
- **Press Start Pad.**

Program 1 Reheat Soup/Coffee



Program	No. of Serves	Recipe
1-1	1 cup	1 serve = 150 ml at room temperature Expected total cooking time/50 sec.
1-2	2 cups	1 serve = 150 ml at room temperature Expected total cooking time/1 min. 30 sec.
1-3	3 cups	1 serve = 150 ml at room temperature Expected total cooking time/2 min.

Program 2 Reheat Meal



Recipe
This menu can be used to serve a standard meal for 1 on plate (example rice, curry, sabji; pulao, biriyani/kichidi/pongal/noodles/fried rice and side dish; idly, sambar etc. which are at room temperature.) Expected total cooking time/1 min. 30 sec.

Program 3 Reheat Fried Items



Note: Usage of crispy plate or a flat aluminum/stainless steel plate by customer is recommended for better performance.

Recipe
This is useful to reheat Samosa, Vada, Dough nut, Puffs etc, which are at room temperature. Heat 1 or 2 pieces at a time. Expected total cooking time/2 min. 30 sec.

Auto Menu

[2] Main Dish



- **Select desired category.**
The auto indicator lights and the program number 4 appears in the display.
- **Press Up/Down pad to select the suitable number in below chart.**
- **Press Start Pad.**

Program 4 Steamed Rice
Number of serves: 3 Servings



Recipe	Step 1
Rice 1 cup Water 2- 2 ½ cups, depending on quality of rice Expected total cooking time/17 min.	Wash the rice well and drain. Place it in a MW safe casserole. (Capacity not less than 1 ½ L) Add the measured water. Soak for 15 minutes. Cover the casserole partially with a lid, leaving a vent. Place in the MWO and press start. When done, stand covered for 5 min. Then gently fluff up the rice with a fork.

Program 5 Peas Pulao
Number of serves: 3 Servings

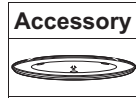

Recipe	Step 1	Beep	Step 2
Basmathi Rice 1 cup Water 2-2 ¼ cups Oil or Ghee 2 Tbsp Onion 1 cup, thinly sliced Cloves 4 Cardamom 3 Cinnamon 2 pieces Salt to taste Fresh/frozen green peas ½ cup (if using frozen peas, soak in water for 15 minutes and drain) Coriander leaves 2 Tbsp, chopped Expected total cooking time/33 min.	Wash the rice well and drain. Add the measured water and soak for 15 min. Add salt, green peas and coriander leaves and reserve. Pour oil/ghee in a MW safe casserole. (Capacity not less than 2 L) Add onion, cloves, cardamom and cinnamon. Mix well. Place the casserole in the MWO and press start.	Wait for beep (Beeping 8 min. after start)	After the beep, add the rice with the water and peas. Mix well and return to MWO. Cover partially, leaving a vent. Press start. When done, stand covered without disturbing for 5 min. Fluff up gently with a fork and serve hot.

Auto Menu

[2] Main Dish

Program 6 Veg Biryani

Number of serves: 4 Servings

Accessory



Recipe	Step 1	Beep	Step 2
Basmati rice 1 cup Water 2 ¼ cups Salt to taste Mint leaves 2 Tbsp, chopped Coriander leaves 2 Tbsp, chopped Mixed vegetables 1 cup, cut into ½ cm cubes Chilli powder ½ tsp Turmeric powder ½ tsp Coriander powder ½ tsp Ghee/oil 2 Tbsp Onion 1 cup, thinly sliced Green chillies 2, minced Ginger 1 tsp, minced Garlic 2 tsp, minced Cloves 3 Cinnamon 2 pieces Cardamom 3 Star anise 1	Wash the rice and drain well. Add 2 ¼ cups of water and soak for 15 min. Add salt, mint and coriander leaves, mixed vegetables and all the powders. Pour the ghee or oil in a MW safe casserole (minimum capacity 2 L.) Add all the ingredients from onion to star anise. Keep in MWO and press start.	Wait for beep (Beeping 5 min. after start)	After the beep, add the rice mixture, along with soaking water. Mix gently. Cover partially with a lid and return to MWO. Press start. When done, cover fully and leave without disturbing for 10 min. Mix gently and serve hot.
Expected total cooking time/31 min.			

Auto Menu

[2] Main Dish

Program 7

Fish Pulao

Number of serves: 3 Servings

Accessory



Recipe		Step 1	Beep	Step 2
King fish*	350 g, steamed	<p>Discard the skin and bones from fish and flake it. Mix with salt, green chilli and garam masala. Wash the rice and drain well. Add water, coconut milk and tomato puree. Add salt and chilli powder.</p> <p>Pour the oil in a MW safe casserole. (Capacity not less than 2 L) Add cloves, cinnamon, ajwain, (optional) bay leaf and pepper. Mix well and keep in MWO. Select the auto menu and press start.</p>	<p>Wait for beep (Beeping 3 min. after start)</p>	<p>After the beep, add the rice mixture along with the soaking liquid. Mix well. Cover partially with a lid, leaving a vent. Return to MWO and press start. When done, cover fully and leave without disturbing for 10 min. Gently mix in the fish. Serve after 5 min. garnished with fried onions. (optional)</p>
Green chilli	1-2, minced			
Salt to taste				
Garam masala	½ tsp			
Basmati Rice	1 cup			
Water	1 ½ cups			
Tomato puree	¼ cup			
Coconut milk	¾ cup			
Salt to taste				
Chilli powder	½ tsp or to taste			
Oil	2 Tbsp			
Cloves	3			
Cinnamon	2 pieces			
Ajwain	¼ tsp, optional			
Bay leaf	1			
Pepper corns	½ tsp, crushed			
Fried onions to garnish, optional				
* Auto menu - Steam Fish; any other white flaky fish may be used				
Expected total cooking time/28 min.				

Accessory



Program 8

Kichidi

Number of serves: 4 Servings

Recipe		Step 1	Beep	Step 2
Rice	¾ cup	<p>Wash the rice and dal and drain. Add water, carrot, beans and salt and keep aside.</p> <p>Pour the oil in a MW safe casserole. (Minimum capacity 2 L) add cloves, cinnamon, green chillies. Place in MWO. Select the auto menu and press start.</p>	<p>Wait for beep (Beeping 3 min. after start)</p>	<p>After the beep, add the rice mixture, stir well and return to MWO and press start. (do not cover) When done, mix well and keep covered at least for 5 min., before serving.</p>
Moong dal	⅓ cup			
Water	3 ½ cups			
Carrot	1 small, grated			
Beans	4-6, finely chopped			
Salt to taste				
Oil	2 Tbsp			
Cloves	3-4			
Cinnamon	2 pieces			
Green chillies	2, slit			
Onion	½ cup, chopped finely			
Expected total cooking time/38 min.				

Auto Menu

[2] Main Dish

Program 9 Pongal

Number of serves: 3 Servings

Accessory



Recipe		Step 1	Beep	Step 2
Rice	¾ cup	Wash the rice and dal well. Drain and place in a MW safe casserole. (Capacity not less than 2 L) Add rest of the ingredients. Place inside the MWO (do not cover), select the auto menu and press start.	Wait for beep (Beeping 30 min. after start)	After the beep, stir well and press start. When done, mix well and serve hot.
Moong dal	⅓ cup			
Water	4 cups			
Ghee/oil	2 Tbsp			
Black pepper corns	½ tsp, crushed			
Cumin seeds	1 tsp, crushed			
Asafoetida	¼ tsp, optional			
Salt to taste				
Roasted cashew nuts	2 Tbsp, chopped			
Expected total cooking time/40 min.				

Program 10 Veg Hot Pot

Number of serves: 4 Servings

Accessory



Recipe		Step 1	Beep	Step 2
Cooked vegetables*	400 g	Mix the vegetables with paneer/tofu, salsa, salt, pepper and herbs. Toss in butter. Mix corn flour with water and add to vegetable mixture. Place the mixture in a MW safe 20-22 cm round dish. Cover with a lid and keep in MWO. Select the auto menu and press start.	Wait for beep (Beeping 5 min. after start)	After the beep, sprinkle cheese on top. Return to MWO and press start. When done, serve hot.
Paneer/tofu	100 g cut into 2 cm cubes			
Salsa (store bought)	½ cup			
Salt and pepper to taste				
Mixed dried herbs	½ tsp, optional			
Butter	2 Tbsp			
Corn flour	1 Tbsp			
Water/vegetable stock	2 Tbsp			
Cheddar cheese	8 Tbsp, grated			
* Auto menu Cook Vegetables; choose from carrot, beans, green peas, capsicum, celery, Mushroom, baby corn.				
Expected total cooking time/7 min.				

Auto Menu

[2] Main Dish

Program 11 Corn and Capsicum Rice

Number of serves: 3 Servings

Accessory



Recipe	Step 1	Beep	Step 2
Basmati rice 1 cup Water 2 ½ cups Red and green capsicum 1 cup, cut into 1.5 cm pieces Chilli powder ½ tsp Coriander powder ½ tsp Cumin powder ½ tsp Salt to taste Oil/ghee 2 Tbsp Onion ½ cup, finely chopped Garlic 1 Tbsp, finely chopped Cooked corn kernels ½ cup Coriander leaves 2 Tbsp, chopped Expected total cooking time/31 min.	Wash the rice, drain and soak in 2 ½ cups of water for 15 min. Add red and green capsicum, chilli powder, coriander powder, cumin powder and salt. Pour the oil in a MW safe casserole (minimum capacity 2 L). Add onion and garlic. Keep in MWO, select the auto menu and press start.	Wait for beep (Beeping 5 min. after start)	After the beep, add the rice mixture. Cover partially with a lid, leaving a vent. Return to MWO and press start. When done, cover fully and leave aside for 5 min. Add cooked corn kernels and coriander leaves. Mix gently and serve hot.

Program 12 Vangi Bhath

Number of serves: 4 Servings

Accessory



Recipe	Step 1	Beep	Step 2
Steamed rice* 3 cups Grated coconut ½ cup Salt to taste Water ¼ cup Oil 2 Tbsp Cloves 2 Cinnamon 2 pieces Sha jeera ¼ tsp Desiccated coconut 4 Tbsp Coriander powder ½ tsp Cumin powder ½ tsp Pepper powder ½ tsp Chilli powder ½ tsp Turmeric powder ½ tsp Long purple Brinjal 250 g, cut into 2 cm slices Salt to taste Water 2 Tbsp Seasoning Ghee 1 Tbsp Mustard 1 tsp Urad dal 2 tsp Pea nuts 1 Tbsp Curry leaves few * Auto menu - Steamed Rice Expected total cooking time/13 min.	Mix rice with grated coconut, salt and water. Pour oil in a MW safe casserole (minimum capacity 2 L). Add all the ingredients from cloves to brinjal. Dissolve salt in 2 Tbsp of water and add. Mix well and place in MWO. Select the auto menu and press start.	Wait for beep (Beeping 8 min. after start)	After the beep, add the rice mixture and mix well. Cover with a lid and return to MWO. Press start. When done, prepare the seasoning (tadka/bagar) and add to the bhath. Mix gently and serve hot.

Auto Menu

[2] Main Dish

Program 13 Tomato Rice

Number of serves: 3 Servings

Accessory



Recipe		Step 1	Beep	Step 2
Steamed rice*	3 cups	Mix the rice with tomato puree, water, chilli powder and salt. Pour the oil in a MW safe casserole. (Capacity not less than 2 L) Add onion and green chillies. Select the auto menu and press start.	Wait for beep (Beeping 4 min. after start)	After the beep, add the rice mixture. Mix well, cover with a lid, return to MWO and press start. When done, prepare the seasoning (tadka/bagar) and add. Mix gently and serve hot.
Tomato puree	¼ cup			
Water	¼ cup			
Chilli powder	½ tsp			
Salt to taste				
Oil	1 ½ Tbsp			
Onion				
	½ cup finely chopped (50 g)			
Green chilli	2, slit			
Seasoning				
Oil	2 tsp			
Mustard	1 tsp			
Urad dal	2 tsp			
Curry leaves	few			
* Auto menu - Steamed Rice				
Expected total cooking time/9 min.				

Program 14 Paneer Pudina Pulao

Number of serves: 3 Servings

Accessory



Recipe		Step 1	Beep	Step 2
Basamathi rice	1 cup	Wash the rice, drain well and add 2-2 ½ cups of water. Let it soak for 15 min. Add salt and mint leaves. Pour the oil or ghee in a MW safe casserole (minimum capacity 2 L). Add onion, ginger, garlic, green chillies, cloves and cinnamon. Place in MWO. Select the auto menu and press start.	Wait for beep (Beeping 7 min. after start)	After the beep, add the rice with the water. Mix well. Partially cover with a lid, leaving a vent. Return to MWO and press start. When done, keep covered for 5 min. Add the paneer cubes and mix gently. Serve hot.
Water	2-2 ½ cups			
Salt to taste				
Mint leaves	½ cup, roughly chopped			
Oil/ghee	2 Tbsp			
Onion	1 cup, thinly sliced			
Ginger				
	3 cm piece, finely chopped			
Garlic	6 cloves, finely chopped			
Green chillies	2, finely chopped			
Cloves	4			
Cinnamon	2 pieces			
Paneer cubes	150 g, fried			
Expected total cooking time/32 min.				

Auto Menu

[2] Main Dish

Program 15 Palak Rice

Number of serves: 3 Servings

Accessory



Recipe	Step 1	Beep	Step 2
Steamed rice* 3 cups Salt ½ tsp Oil 2 Tbsp Palak 2 cup, finely chopped Green chillies 2, chopped Ginger 1 tsp, chopped Chillli powder ½ tsp Turmeric powder ½ tsp Garam masala powder 1 tsp Kasoori methi ½ tsp Salt ½ tsp Lime juice to taste * Auto menu - Steamed Rice Expected total cooking time/8 min.	Mix rice with salt and keep aside. Pour the oil in a MW safe casserole. (Minimum capacity 2 L) Add rest of the ingredients except the lime juice. Mix well and keep in MWO. Select the auto menu and press start.	Wait for beep (Beeping 5 min. after start)	After the beep, add the rice, mix well and cover with a lid. Return to MWO. Press start. When done, leave without disturbing for 5 min. Sprinkle lime juice on rice and mix gently. Serve hot.

Program 16 Chicken/Mushroom Fried Rice

Number of serves: 3 Servings

Accessory



Recipe	Step 1	Beep	Step 2
Steamed rice* 3 cups Soya sauce 1 tsp Salt to taste Ajinomoto ¼ tsp, optional Water/chicken stock ¼ cup Oil 2 Tbsp Spring onion ½ cup, chopped Capsicum ¼ cup, chopped Mushrooms ½ cup, chopped OR Cooked chicken** ½ cup, shredded * Auto menu - Steamed Rice ** Auto menu - Cook Chicken Expected total cooking time/9 min.	Mix steamed rice with Soya sauce, salt, Ajinomoto and water/ chicken stock. Pour the oil in a MW safe casserole. (Minimum capacity 2 L). Add spring onion, capsicum, and mushroom/chicken. Mix well and keep in MWO. Select the auto menu and press start.	Wait for beep (Beeping 4 min. after start)	After the beep, add the rice and mix well. Cover with a lid and return to MWO. Press start. When done, serve hot.

Auto Menu

[2] Main Dish

Program 17 Lemon Rice

Number of serves: 3 Servings

Accessory



Recipe	Step 1	Beep	Step 2
<p>Steamed rice* 3 cup, at room temperature</p> <p>Turmeric powder ½ tsp</p> <p>Chopped coriander leaves 2 Tbsp</p> <p>Water ¼ cup</p> <p>Salt to taste</p> <p>Oil 2 Tbsp</p> <p>Mustard seeds 1 tsp</p> <p>Urad dal 2 tsp</p> <p>Green chillies 2-3, chopped</p> <p>Curry leaves few</p> <p>Lime juice 2 Tbsp</p> <p>* Auto menu - Steamed Rice</p> <p>Expected total cooking time/5 min.</p>	<p>Mix all the ingredients from rice to salt together and keep aside.</p> <p>Pour the oil in a MW safe dish.</p> <p>Add all the ingredients from mustard to curry leaves. Place in MWO and select auto menu, press start.</p>	<p>Wait for beep (Beeping 2 min. after start)</p>	<p>After the beep, add the rice mixture, cover and return to MWO, press start. When done, add lime juice, mix well and serve hot.</p>

Program 18 Orange Rice

Number of serves: 3-4 Servings

Accessory



Recipe	Step 1	Beep	Step 2
<p>Basamathi rice 1 cup</p> <p>Water 1 ½ cups</p> <p>Orange juice (no added sugar) 1 cup</p> <p>Chilli powder ¾ tsp</p> <p>Coriander leaves 4 Tbsp, chopped</p> <p>Salt to taste</p> <p>Carrot 1 medium size, grated</p> <p>Ghee/oil 2 Tbsp</p> <p>Onion 1 cup, thinly sliced</p> <p>Cloves 3</p> <p>Cinnamon 2 pieces</p> <p>Cardamoms 3</p> <p>Star anise 1</p> <p>Sha jeera ¼ tsp</p> <p>Bay leaf 1</p> <p>Expected total cooking time/31 min.</p>	<p>Wash the rice, drain well and add 1 ½ cup of water.</p> <p>Let it soak for 15 min.</p> <p>Add orange juice, chilli powder, coriander leaves, salt and carrot.</p> <p>Pour the oil in MW safe casserole (Minimum capacity 2 L) Add all the ingredients from onion to bay leaf. Mix well and place in the MWO.</p> <p>Select the auto menu and press start.</p>	<p>Wait for beep (Beeping 5 min. after start)</p>	<p>After the beep add the rice mixture. Mix well.</p> <p>Cover partially with a lid, leaving a vent. Press start.</p> <p>When done, cover and leave without disturbing for 5 min. Then gently mix and serve hot.</p>

Auto Menu

[3] Side Dish (Gravy)



- **Select desired category.**

The auto indicator lights and the program number 19 appears in the display.

- **Press Up/Down pad to select the suitable number in below chart.**

- **Press Start Pad.**

Program 19 Aloo Matar

Number of serves: 3 Servings

Accessory



Recipe	Step 1	Beep	Step 2
Frozen green peas 200 g Cooked potato* 150 g, at room temperature Tomato puree 1/3 cup Chilli powder 1 tsp or to taste Turmeric powder 1/2 tsp Garam masala powder 1/2 tsp Salt to taste Water 3/4 cup Oil 3 Tbsp Onion 1/2 cup, chopped finely Garlic 6 cloves, chopped finely Ginger 2 cm, chopped finely Coriander leaves to garnish * Auto menu - Cook Potato Expected total cooking time/13 min.	Soak the peas in water for 15 minutes and drain. Peel and cut the potatoes into 3 cm cubes. Mix tomato puree with all the powders, water and salt. Pour the oil in a 18-20 cm MW safe dish. Add onion, ginger and garlic and mix well. Place in the MWO. Select the auto menu and press start.	Wait for beep (Beeping 8 min. after start)	After the beep, add peas, potatoes, and tomato puree mixture. Mix well and return to MWO. Cover the dish with a lid. Press start. When done, garnish the curry with chopped coriander leaves and serve hot.

Program 20 Cook Chicken

Accessory



Recipe	Step 1
Chicken pieces 500 g Water 250 ml Salt 1/2 tsp Expected total cooking time/15 min.	Place the chicken pieces in a MW safe casserole. Dissolve the salt in water and add to the chicken. Cover with a lid and place in MWO. Select the auto menu and press start. When done, leave without disturbing for 10 min. Strain and reserve the stock to use in soups and other recipes. The chicken can be used in sandwiches and other recipes using cooked/shredded chicken. The stock and the chicken can be stored in refrigerator up to 3 days and used as required. It may be stored in the freezer up to 2 weeks.

Auto Menu

[3] Side Dish (Gravy)

Program 21 Paneer/Chicken Makhni

Number of serves: 4 Servings

Accessory



Recipe	Step 1	Beep	Step 2
<p>For paneer makhni, use 200 g paneer tikka*/fried paneer cubes For chicken makhni use 300 g chicken tikka**/cooked boneless chicken*** Auto menu - Paneer Tikka* Auto menu - Chicken Tikka** Auto menu - Cook Chicken*** Gravy Tomato puree ¾ cup Onion ¼ cup, grated Ginger-garlic paste 2 tsp Cloves 3 Cardamom 3 Chili powder 1 tsp Green chili 1, slit Ghee/oil 1 Tbsp Kasoori methi 2 tsp Cashew nut 2 Tbsp, ground to a paste Water 1 cup Salt to taste Sugar ½ tsp Fresh cream 2 Tbsp Butter 2 Tbsp Extra cream to garnish, optional</p> <p>Expected total cooking time/15 min.</p>	<p>Combine tomato puree, onion, ginger-garlic paste, cloves, cardamom, green chili and ghee/oil in a 20-22 cm round MW safe dish. Keep in MWO. Select the auto menu and press start.</p>	<p>Wait for beep (Beeping 8 min. after start)</p>	<p>After the beep add paneer/chicken, cashew nut paste, Kasoori Methi, water, salt and sugar. Mix well. Return to MWO and press start. When done, stir in the cream and butter. Serve hot, garnished with extra cream. (optional)</p>

Auto Menu

[3] Side Dish (Gravy)

Program 22 Veg Rasdar

Number of serves: 4 Servings

Accessory



Recipe	Step 1	Beep	Step 2
<p>Cooked mixed vegetables* 500 g Water ¾-1 cup Salt to taste Onion ¼ cup, chopped Garlic 6 cloves Ginger 3 cm piece Curry powder 3 tsp or to taste Garam masala powder 1 tsp Tomato puree ¼ cup Oil 2-3 Tbsp * Auto menu - Cook Vegetables</p> <p>Expected total cooking time/13 min.</p>	<p>Mix vegetables with water and salt and keep aside. Grind onion, ginger and garlic into a paste, without using any water. Mix with curry powder and garam masala powder. Add tomato puree and oil. Mix well and place in a MW safe casserole. (Capacity not less than 1 ½ L) Keep in MWO, select the auto menu and press start.</p>	<p>Wait for beep (Beeping 5 min. after start)</p>	<p>After the beep, add the reserved vegetable mixture, mix well and cover with a lid. Return to MWO and press start. When done, serve hot, garnished with coriander leaves.</p>

Program 23 Fish Coconut Curry

Number of serves: 4 Servings

Accessory



Recipe	Step 1	Beep	Step 2
<p>Most type of fish can be used in this curry. Pomfret, Mackerel, King fish, Sardines, Red snappers are some examples. If using small fish, clean them and keep them whole. Fish 500 g Green chillies 2, chopped Tamarind paste ¾ tsp Salt ½ tsp Grated coconut 1 ½ cups Chilli powder 2 tsp or to taste Coriander powder 1 tsp Cumin powder ½ tsp Garlic 4 cloves Onion ½ cup, finely chopped (50 g) Water 2 cup Salt to taste</p> <p>Expected total cooking time/15 min.</p>	<p>Cut the fish into 4 cm cubes (keep small fish whole). Mix with green chillies, salt and tamarind paste. Grind coconut with all the powders and garlic together to a very smooth paste, using some water. Add onion, salt and 2 cup of water. Mix well and pour in a MW safe casserole. (Minimum capacity 2 L) Place in the MWO. Select the auto menu and press start.</p>	<p>Wait for beep (Beeping 7 min. after start)</p>	<p>After the beep, add the fish, mix well. Return to MWO and cover with a lid. Press start. When done, leave without disturbing for 10 min. Serve hot.</p>

Auto Menu

[3] Side Dish (Gravy)

Program 24 Shahi Mushroom Curry

Number of serves: 4 Servings

Accessory



Recipe		Step 1	Beep	Step 2
Button Mushrooms	200 g	Cut the mushrooms into quarters. Grind onion, ginger and garlic to a paste, without adding any water. Grind cashew nuts with little water to a paste. Mix cashew nut paste with coconut milk, Kasoori methi, water and salt. Mix the onion paste with tomato puree, all the powders and oil. Place in a MW safe casserole (capacity not less than 1 ½ L.) keep it in MWO. Select the auto menu and press start.	Wait for beep (Beeping 7 min. after start)	After the beep add mushrooms and coconut milk mixture Mix well. Cover with a lid and return to MWO. Press start. When done, stir in the cream and serve hot.
Onion	1 cup, chopped			
Garlic	6 flakes chopped			
Ginger	3 cm chopped			
Tomato puree	¼ cup			
Chilli powder	1 tsp or to taste			
Turmeric powder	½ tsp			
Cumin powder	½ tsp			
Garam masala powder	1 tsp			
Cashew nuts	2 Tbsp			
Oil/ghee	2 Tbsp			
Kasoori methi	2 tsp			
Coconut milk	½ cup			
Water	¼ cup			
Salt to taste				
Fresh cream	¼ cup			
Expected total cooking time/12 min.				

Program 25 Prawn Malai Curry

Number of serves: 4 Servings

Accessory



Recipe		Step 1	Beep	Step 2
Coconut milk	1 Packet (200 ml)	Mix the coconut milk with curds, tomato puree, water and salt. Combine the prawns with ginger garlic paste and all the powders. Place them in a MW safe 22 cm round dish. Pour in the oil and mix well. Keep the dish in MWO. Select the auto menu and press start.	Wait for beep (Beeping 3 min. after start)	After the beep add the coconut milk mixture. Mix well. Keep in the MWO and cover with a lid. Press start. When done, leave without disturbing for 5 min. Mix and serve hot.
Curd	3 Tbsp, beaten till smooth			
Tomato puree	3 Tbsp			
Water	½ cup			
Salt to taste				
Peeled prawns	400 g			
Ginger garlic paste	2 tsp			
Chilli powder	1 tsp or to taste			
Turmeric powder	½ tsp			
Garam masala powder	½ tsp			
Oil	2 Tbsp			
Expected total cooking time/9 min.				

Auto Menu

[3] Side Dish (Gravy)

Program 26

Potato Aloo Bhaji

Number of serves: 4 Servings

Accessory



Recipe	Step 1	Beep	Step 2
<p>Cooked potato* 350 g Tomato puree 1 Tbsp Chilli powder ½ tsp Turmeric powder ½ tsp Salt to taste Water 1 cup Oil 1 tbsp Onion 1 ½ cups, finely sliced Green chilli 1-2, slit Coriander leaves to garnish * Auto menu - Cook Potato</p> <p>Expected total cooking time/15 min.</p>	<p>Peel the potatoes and crumble them, mashing some of them. Mix with tomato puree, chilli powder, turmeric powder, salt and water. Pour the oil in a MW safe casserole (minimum capacity 1 ½ L). Add onion and green chilli. Keep in MWO. Select the auto menu and press start.</p>	<p>Wait for beep (Beeping 7 min. after start)</p>	<p>After the beep add the potato mixture. Cover with a lid, return to MWO and press start. When done, garnish with coriander leaves and serve with pooris.</p>

Program 27

Veg Stew

Number of serves: 4 Servings

Accessory



Recipe	Step 1	Beep	Step 2
<p>Cooked mixed vegetables* 400 g Coconut milk 1 packet (200 ml) Water 250 ml Rice flour 1 tbsp Salt to taste Oil 2 Tbsp Cloves 3 Cinnamon 2 pieces Onion ½ cup, chopped Green chillies 3-4 slit Ginger 3 cm, chopped Black pepper ½ tsp, crushed * Carrot, beans, potato, green peas; Auto menu - Cook Vegetables</p> <p>Expected total cooking time/16 min.</p>	<p>Combine vegetables with coconut milk. Mix rice flour with some of the water and add to vegetables. Add remaining water and salt. Pour the oil in a MW safe casserole. (Minimum capacity 1 ½ L) Add all the ingredients from cloves to black pepper. Mix well and place in MWO. Select the auto menu and press start.</p>	<p>Wait for beep (Beeping 5 min. after start)</p>	<p>After the beep, add the vegetable mixture. Cover with a lid and return to MWO. Press start. When done, serve hot garnished with coriander leaves.</p>

Auto Menu

[3] Side Dish (Gravy)

Program 28 Fish Tamarind Curry (H)

Number of serves: 4 Servings

Accessory



Recipe	Step 1	Beep	Step 2
<p>This curry may be prepared with any fish of your choice. If using small fish, clean them and keep whole.</p> <p>Fish pieces 400 g Salt ½ tsp Onion 1 cup, finely chopped Garlic 4 cloves, minced Curry powder 2 Tbsp or to taste Water 1 ¼ cups Tamarind paste 1-1 ½ tsp Salt to taste Seasoning Oil 2 Tbsp Mustard 1 tsp Curry leaves few Mix fish with ½ tsp salt.</p> <p>Expected total cooking time/22 min.</p>	<p>Place onion and garlic in a MW safe 22 cm round dish. Add curry powder, water, salt and tamarind. Mix well and keep in MWO. Select the auto menu and press start.</p>	<p>Wait for beep (Beeping 12 min. after start)</p>	<p>After the beep, add the fish, mix and cover with a lid. Return to MWO. Press start. When done let it stand for 10 min. Prepare the seasoning and add to the curry. Serve hot.</p>

(H) : Healthy Menu

Program 29 Kadi

Number of serves: 4 Servings

Accessory



Recipe	Step 1	Beep	Step 2
<p>Curds 1 cup Water 3 cups Besan 3 Tbsp Chilli powder 1 tsp Cumin powder ½ tsp Coriander powder ½ tsp Turmeric powder ½ tsp Salt to taste Sugar ½ tsp, optional Seasoning Oil 1 Tbsp Mustard 1 tsp Cumin seeds 1 tsp Curry leaves few</p> <p>Expected total cooking time/15 min.</p>	<p>Beat the curds till smooth. Add water, besan, all the powders, salt and sugar. Mix till smooth. Pour in a MW casserole. (Minimum capacity 2 L) Keep in MWO. Select the auto menu and press start.</p>	<p>Wait for beep (Beeping 12 min. after start)</p>	<p>After the beep, stir well and press start. When done, prepare the seasoning (tadka/bagar) and add to the kadi. Serve garnished with coriander leaves.</p>

Auto Menu

[3] Side Dish (Gravy)

Program 30 Cook Dal

Accessory



Recipe	Step 1	Beep	Step 2
<p>Tovar Dal 100 g</p> <p>Expected total cooking time/28 min.</p>	<p>Soak the dal in water for 4-6 hours. Drain and add 1 ½-2 cups of water. Place in a MW safe casserole (capacity not less than 2 L) do not cover. Select the auto menu and press start.</p>	<p>Wait for beep (Beeping 23 min. after start)</p>	<p>After the beep, stir well and press start. When done, mash well and use in recipes as needed. This dal can be stored in refrigerator for 2-3 days and used as required.</p>

Program 31 Mooli Sambar (H) Number of serves: 4 Servings

Accessory



Recipe	Step 1	Beep	Step 2
<p>Radish 200 g</p> <p>Sambar onions 100 g</p> <p>Water 1 cup</p> <p>Cooked, mashed dal* 1 cup</p> <p>Tamarind paste 1 tsp or to taste</p> <p>Sambar masala 1 Tbsp or to taste</p> <p>Salt to taste</p> <p>Water 1 cup</p> <p>Seasoning</p> <p>Oil 1 Tbsp</p> <p>Mustard 1 tsp</p> <p>Curry leaves few</p> <p>* Auto menu - Cook Dal</p> <p>Expected total cooking time/18 min.</p>	<p>Peel and cut radish into ½ cm round slices. Peel the onions and cut larger ones into halves, leaving the small ones whole. Mix the dal with sambar masala, tamarind paste, salt and water. Place the vegetables in a MW safe casserole (capacity not less than 2 L) add 1 cup water. Cover with a lid and place in MWO. Select the auto menu and press start.</p>	<p>Wait for beep (Beeping 10 min. after start)</p>	<p>After the beep, add the dal mixture. Stir well and return to MWO. Do not cover. Press start. When done, prepare the seasoning and add. Mix well and serve hot. The sambar may thicken on cooling. Add boiled water to thin down.</p>

(H) : Healthy Menu

Auto Menu

[3] Side Dish (Gravy)

Program 32 Palak Dal (H)

Number of serves: 4 Servings

Accessory



Recipe	Step 1	Beep	Step 2
<p>Cooked toor dal 1 ½ cups, mashed*</p> <p>Salt to taste</p> <p>Water 1 cup</p> <p>Oil 2 Tbsp</p> <p>Palak 2 cups, finely chopped</p> <p>Salt ½ tsp</p> <p>Green chillies 2, chopped</p> <p>Ginger 1 tsp, chopped</p> <p>Chilli powder ½ tsp</p> <p>Turmeric powder ½ tsp</p> <p>Coriander powder 1 tsp</p> <p>Cumin powder ½ tsp</p> <p>Cloves 2</p> <p>Cinnamon 2 pieces</p> <p>* Auto menu - Cook Dal</p> <p>Expected total cooking time/20 min.</p>	<p>Mix the dal with water and salt.</p> <p>Pour the oil in MW safe casserole (minimum capacity 2 L) add all the ingredients from palak to cinnamon. Place in MWO. Select the auto menu and press start.</p>	<p>Wait for beep (Beeping 8 min. after start)</p>	<p>After the beep, add the dal, mix well. Return to MWO. Press start. When done, serve hot.</p>

(H) : Healthy Menu

Auto Menu

[4] Side Dish (Dry)



- **Select desired category.**
The auto indicator lights and the program number 33 appears in the display.
- **Press Up/Down pad to select the suitable number in below chart.**
- **Press Start Pad.**

Program 33 Cook Vegetables



Recipe	Step 1
Fresh vegetables 500 g Water 2 Tbsp Expected total cooking time/10 min.	Cut the vegetables into medium size pieces (1-1.5 cm cubes/slices). Sprinkle with water. Place in a wide shallow MW safe dish and cover with a lid. Place in MWO, select the auto menu and press start. When done, use in recipes as needed.

Program 34 Steam fish



Recipe	Step 1
Fish slices 400 g (not more than 2 cm thick) Expected total cooking time/ 6 min. 30 sec.	Place the fish slices in a single layer in a MW safe flat dish. Cover with a lid and keep in MWO. Select the auto menu and press start. When done, let it stand for 10 min. Use in fish cutlet, spicy fish scramble or other dishes as required.

Program 35 Potato Curry

Number of serves: 4 Servings



Recipe	Step 1	Beep	Step 2
Cooked potato* 500 g Chilli powder 1 tsp or to taste Turmeric powder ½ tsp Garam masala powder ½ tsp Salt to taste Water ¼ cup Oil 3-4 Tbsp Mustard 1 tsp Cumin seeds 1 tsp * Auto menu - Cook Potato Expected total cooking time/8 min.	Peel and cut potatoes into 3 cm cubes. Mix all the powders and salt with the water and mix with the potatoes. Pour the oil in a MW safe 20-22 cm round dish. Add mustard and cumin seeds. Place in MWO. Select the auto menu and press start.	Wait for beep (Beeping 3 min. after start)	After the beep, add the potatoes, mix well, and cover with a lid. Return to MWO and press start. When done, serve hot.

Auto Menu

[4] Side Dish (Dry)

Program 36 Chicken Kadai Masala

Number of serves: 4 Servings

Accessory



Recipe	Step 1	Beep	Step 2
<p>Cooked chicken* 500 g Green chillies 2, finely chopped Ginger 3 cm piece, finely chopped Mint leaves 2 Tbsp, chopped Coriander leaves 2 Tbsp, chopped Tomato puree ¼ cup Chillli powder ¾ tsp or to taste Pepper powder ½ tsp Cumin powder ½ tsp Coriander powder ¾ tsp Salt to taste Chicken stock/water ⅓ cup Oil 2 Tbsp Onion 1 ½ cups, chopped finely * Auto menu - Cook Chicken</p> <p>Expected total cooking time/16 min.</p>	<p>Remove the skin and bones from chicken and flake the meat. Mix it with all the ingredients from green chillies to stock/water. Pour the oil in a MW safe 20-22 cm round dish. Add onion, mix well and place in MWO Select the auto menu and press start.</p>	<p>Wait for beep (Beeping 8 min. after start)</p>	<p>After the beep, add the chicken, mix well, cover with a lid and press start. When done, serve hot.</p>

Program 37 Chutney Fish

Number of serves: 4 Servings

Accessory



Recipe	Step 1
<p>Use any big flaky fish like king fish, Bekti or black pomfret Fish slices 400 g (1 cm thick) Lime juice 2 tbsp Pepper powder ½ tsp Banana leaves few Oil to brush Chutney Grated coconut 1 cup Green chillies 6-8 Ginger 2 cm Garlic 4 cloves Cumin seeds 1 tsp Coriander leaves ¾ cup, chopped Salt to taste</p> <p>Expected total cooking time/5 min.</p>	<p>If the fish slices are big, cut each into 2 pieces and discard the centre bone. Apply lime juice and pepper on both sides. Cut banana leaves into pieces, large enough to wrap the fish slices. Plunge the leaves in boiling hot water for 5 min. Drain and wipe the leaves and brush the shiny side with oil. Grind all the ingredients for chutney together using minimum amount of water. Apply chutney to both sides of fish slices and place each on the greased side of a banana leaf. Fold the leaves to make neat parcels. Secure with thread. Place the parcels on the turn table, along the outer edge. Select the auto menu and press start. When done, let it stand for 5-7 min. Serve hot.</p>

Auto Menu

[4] Side Dish (Dry)

Program 38 Sprouted Moong Salad (H)

Number of serves: 4 Servings

Accessory



Recipe	Step 1
<p>Sprouted green gram 1 cup</p> <p>Tomato ½ cup, chopped</p> <p>Onion ½ cup, chopped</p> <p>Green chillies 2, minced</p> <p>Ginger 1 tsp, minced</p> <p>Pomegranate seeds 1 cup</p> <p>Salt, sugar and lime juice to taste</p> <p>Chaat masala to taste</p> <p>Coriander leaves 3 Tbsp, chopped</p> <p>Mint leaves 3 tbsp, chopped</p> <p>Expected total cooking time/7 min.</p>	<p>Place the sprouted moong in a MW safe steamer. Pour 1 cup of boiling hot water in the lower container of the steamer. Cover and keep in MWO. Select the auto menu and press start. When done, cool the sprouts and mix with rest of the ingredients.</p>

(H) : Healthy Menu

Program 39 Stuffed Brinjal

Number of serves: 4 Servings

Accessory



Recipe	Step 1	Beep	Step 2
<p>Small purple brinjals 500 g</p> <p>Onion 1 ½ cups, very finely chopped</p> <p>Curry powder 1 Tbsp or to taste</p> <p>Garam masala powder 1 tsp</p> <p>Salt to taste</p> <p>Jaggery powder 1-2 Tbsp, optional</p> <p>Oil 3 Tbsp</p> <p>Expected total cooking time/13 min.</p>	<p>Cut away the stalks from brinjals. Slit the brinjals into four, without separating the four pieces. Mix all the ingredients from onion to jaggery together. Add one Tbsp of oil and mix well.</p> <p>Stuff the brinjals with this mixture. Arrange them in a wide, shallow MW safe dish, keeping the larger ones on the outer edge and smaller ones in the middle, in a single layer. Cover with a lid. Place in MWO. Select the auto menu and press start.</p>	<p>Wait for beep (Beeping 8 min. after start)</p>	<p>After the beep, open the lid and pour the remaining oil all over the brinjals. Stir well and return to MWO without the cover. Press start. When done serve hot.</p>

Auto Menu

[4] Side Dish (Dry)

Program 40 Kheema Masala

Number of serves: 4 Servings

Accessory



Recipe	Step 1	Beep	Step 2
Minced mutton 500 g Curds ½ cup Tomato puree ¼ cup Chilli powder 2 tsp or to taste Coriander powder 2 tsp Cumin powder 1 tsp Garam masala powder 1 tsp Salt to taste Oil 4 Tbsp Onion 2 ½ cups, minced Ginger 2 tsp, minced Garlic 10 cloves, Minced Mint leaves 3 Tbsp, chopped Coriander leaves 3 Tbsp, chopped Expected total cooking time/23 min.	Mix the minced mutton with curds, tomato puree, all the powders and salt. Marinate for 30 min. Pour the oil in a MW safe casserole. Add onion, ginger and garlic. Mix well and keep inside the MWO. Press start.	Wait for beep (Beeping 15 min. after start)	After the beep, add the kheema mixture. Mix well, cover with a lid and press start. When done, mix in the mint and coriander leaves. Serve hot after 5 min.

Program 41 Spicy Fish Scramble

Number of serves: 4 Servings

Accessory



Recipe	Step 1	Beep	Step 2
This is a very spicy recipe. The chilli powder and green chillies may be reduced if preferred. Steamed King fish* 400 g Chilli powder 2 tsp or to taste Turmeric powder ½ tsp Salt to taste Oil 4 Tbsp Onion 2 ½ cups, minced Ginger 3 tsp, minced Garlic 15 cloves, minced Green chillies 4-6, minced Coriander leaves 4 Tbsp, chopped * Auto menu - Steam Fish Expected total cooking time/23 min.	Remove the skin and bones from fish and flake the fish. Mix it with chilli powder, turmeric powder and salt. Pour the oil in a 22 cm round dish. Add onion, ginger, garlic and green chillies. Mix well and keep in MWO. Select the auto menu and press start.	Wait for beep (Beeping 15 min. after start)	After the beep, add the fish mixture. Mix well, cover with a lid and return to MWO. Press start. When done, mix in the coriander leaves and serve hot.

Auto Menu

[4] Side Dish (Dry)

Program 42 Hot and Sour Plantain

Number of serves: 4 Servings

Accessory



Recipe		Step 1	Beep	Step 2
Red chillies	5-6	Dry roast all the ingredients from red chillies to asafoetida and powder coarsely. Mix with oil. Peel the plantains and cut into 2 cm cubes. Mix with the masala paste. Mix salt and tamarind paste with water and add to plantain. Place the mixture in MW safe 22 cm round dish. Cover with a lid and keep in MWO. Select the auto menu and press start.	Wait for beep (Beeping 5 min. after start)	After the beep, stir the plantains well. Return to MWO (do not cover.) Press start. When done, serve hot.
Coriander seeds	2 tsp			
Cumin seeds	1 tsp			
Fenugreek (methi)	¼ tsp			
Pepper	½ tsp			
Mustard	½ tsp			
Asafoetida	little			
Oil	2 Tbsp			
Curry plantain	2 large (about 400 g)			
Salt to taste				
Tamarind paste	1 tsp			
Water	¼ cup			
Expected total cooking time/8 min.				

Program 43 Paneer Burji

Number of serves: 3-4 Servings

Accessory



Recipe		Step 1	Beep	Step 2
Paneer	200 g, grated	Mix paneer with all the ingredients from chilli powder to tomato puree. Cover and keep aside. Pour the oil in a MW safe 20-22 cm round dish. Add onion, mix well and keep inside the MWO. Select the auto menu and press start.	Wait for beep (Beeping 5 min. after start)	After the beep, add the paneer mixture, cover with a lid and return to the MWO. Press start. When done, serve hot, garnished with coriander leaves.
Chilli powder	¾ tsp or to taste			
Turmeric powder	½ tsp			
Coriander powder	½ tsp			
Cumin powder	½ tsp			
Garam masala powder	½ tsp			
Salt to taste				
Water	½ cup			
Tomato puree	2 Tbsp			
Oil	2 Tbsp			
Onion	½ cup, chopped finely			
Coriander leaves to garnish				
Expected total cooking time/12 min.				

Auto Menu

[4] Side Dish (Dry)

Program 44 Bhindi Masala

Number of serves: 3 Servings

Accessory



Recipe		Step 1	Beep	Step 2
Bhindi	350 g	Cut bhindi into 2-3 cm long pieces. Mix with all the powders. Dissolve salt in 1 Tbsp of water and mix with bhindi. Pour the oil in a MW safe wide dish (20-22 cm round). Add onion and ajwain (optional). Place in MWO. Select the auto menu and press start.	Wait for beep (Beeping 6 min. after start)	After the beep, add bhindi and mix well. Spread evenly in the dish. Cover and return to MWO. Press start. When done, let it stand for 5 min. Mix in lime juice and serve hot.
Chilli powder	$\frac{3}{4}$ tsp or to taste			
Turmeric powder	$\frac{1}{2}$ tsp			
Garam masala powder	$\frac{3}{4}$ tsp			
Salt to taste				
Oil	2 Tbsp			
Onion	1 $\frac{1}{2}$ cup, finely chopped			
Ajwain	$\frac{1}{4}$ tsp, optional			
Lime juice to taste				
Expected total cooking time/14 min.				

Auto Menu

[5] Soup/Snack



- **Select desired category.**
The auto indicator lights and the program number 45 appears in the display.
- **Press Up/Down pad to select the suitable number in below chart.**
- **Press Start Pad.**

Program 45 Tomato Soup

Number of serves: 4 Servings

Accessory



Recipe	Step 1	Beep	Step 2
Butter 2 Tbsp Onion 1/3 cup, chopped Celery 1/4 cup, chopped Garlic 4 cloves, chopped Tomato 250 g, chopped Tomato puree 1/3 cup Water 2 cups Milk 1 cup Salt and pepper to taste Fresh cream 1/4 cup, optional Coriander leaves or parsley to garnish Expected total cooking time/32 min.	Place butter, onion, celery and garlic in a MW safe casserole (minimum capacity 2 L). Place in MWO, select the auto menu and press start.	Wait for beep (Beeping 5 min. after start)	After the beep, add tomato, tomato puree and water. Cover with a lid and press start. When done, cool and blend till smooth. Add milk (pre boiled and cooled) and cream (optional). Add salt and pepper to taste. Reheat before serving. (Auto menu reheat-soup) Serve drizzled with extra cream (optional) and coriander leaves or parsley.

Program 46 Mushroom Soup (H)

Number of serves: 4 Servings

Accessory



Recipe	Step 1
Button mushroom 200 g, sliced Chopped onion 1/3 cup Chopped celery 1/2 cup Chopped garlic 2 Tbsp Water/stock 2 cups Low fat milk 1 cup Salt and pepper to taste Chopped coriander or parsley to garnish Expected total cooking time/21 min.	Place all the ingredients from mushroom to water/stock in a MW safe casserole (not less than 2 L capacity). Cover with lid and place in the MWO. Select the auto menu. Press start. When done, cool the contents till just warm. Blend in a mixer. Add milk, (pre boiled) salt and pepper. Reheat before serving (auto menu reheat soup) and garnish with coriander or parsley.

(H) : Healthy Menu

Auto Menu

[5] Soup/Snack

Program 47 Chicken Vegetable Soup (H)

Number of serves: 4 Servings

Accessory



Recipe	Step 1	Beep	Step 2
Bone less chicken fillet 250 g Water/chicken stock 3 cup Celery ½ cup, chopped Onion ½ cup chopped Salt to taste Broccoli 100 g, cut into bite size pieces Carrot 50 g, cut into ¼ thick slices Green and red capsicum 50 g, cut into 1.5 cm pieces Pepper powder to taste Soya sauce 2 tsp Monosodium glutamate ¼ tsp, optional Expected total cooking time/31 min.	Cut the chicken into 2 cm cubes. Place in a MW safe casserole. (Capacity not less than 2 L) add water/stock, celery onion and salt and place in MWO. Select the auto menu and press start.	Wait for beep (Beeping 16 min. after start)	After the beep, add all the vegetables. Cover and return to MWO. When done, add pepper and more salt if needed. Add soya sauce and monosodium glutamate (optional). Serve hot.

(H) : Healthy Menu

Program 48 Vegetable Soup (H)

Number of serves: 4 Servings

Accessory



Recipe	Step 1
Mixed vegetables*1 250 g Water/veg stock 500 ml Onion ½ cup, minced Garlic 4 flakes, minced Celery ¼ cup, chopped Salt and pepper to taste Low fat milk 250 ml *1 Carrot, beans, broccoli, Mushroom, yellow pumpkin, Knol kol, etc. Expected total cooking time/16 min.	Cut vegetables into cubes and mince in food processor or mixer. Place in a MW safe casserole (minimum capacity 2 L). Add water/stock, onion, garlic, celery, salt and pepper. Cover with a lid and place in the MWO. Select the auto menu and press start. When done, cool it. Take about 1 cup of the vegetables and little coking liquid and blend till smooth. Add it to the remaining soup. Add milk. Reheat before serving. (Auto menu reheat soup)

(H) : Healthy Menu

Auto Menu

[5] Soup/Snack

Program 49

Tomato Rasam

Number of serves: 4 Servings

Accessory



Recipe	Step 1
Mashed cooked dal 2 Tbsp Water 2 cups Tomato 1 small, chopped into ¼ cm pieces Tomato puree 2 Tbsp Rasam powder 1 Tbsp or to taste Curry leaves few Salt to taste Lime juice 1-2 Tbsp Seasoning Oil 1 Tbsp Mustard 1 tsp Expected total cooking time/11 min.	Mix the dal well with water. Add rest of the ingredients except lime juice and the seasoning ingredients. Pour the dal mixture in a MW safe casserole. (Minimum capacity 1 ½ L) (Do not cover) Place in MWO and press start. When done, add lime juice. Prepare the seasoning (tadka, bagar) and add. Mix well and serve hot garnished with coriander leaves.

Program 50

Hara Shorba (H)

Number of serves: 4 Servings

Accessory



Recipe	Step 1	Beep	Step 2
Green peas 150 g Potato 1 small, grated Onion 1 medium size, chopped Ginger 2 cm slice (do not chop) Green chilli 1, chopped Cumin powder ½ tsp Coriander powder ½ tsp Cinnamon powder ½ tsp Water/vegetable stock 2 cups Palak 5-6 leaves, chopped Mint leaves 2 Tbsp, chopped Coriander leaves 2 Tbsp, chopped Salt, pepper and lime juice to taste Expected total cooking time/22 min.	Place the green peas, potato, onion, ginger, green chilli and all the powders in a MW safe Casserole (minimum capacity 2 L). Add water or stock. Cover with a lid and keep in MWO. Select the auto menu and press start.	Wait for beep (Beeping 17 min. after start)	After the beep, add palak, mint and coriander leaves. Cover and return to MWO. Press start. When done, cool the mixture. Lift out the ginger and discard. Blend the soup and add 1 more cup of water or stock. Add salt, pepper and lime juice to taste. Reheat before serving. (Auto menu reheat soup)

(H) : Healthy Menu

Auto Menu

[5] Soup/Snack

Program 51 Cook Potato

Accessory



Recipe	Step 1	Beep	Step 2
<p>Potatoes 4, total wt about 500 g</p> <p>Expected total cooking time/10 min.</p>	<p>Wash the potatoes and prick all over with a fork. Place them on the turn table in MWO like the spokes of a wheel. Select auto menu and press start.</p>	<p>Wait for beep (Beeping 5 min. after start)</p>	<p>After the beep turn over the potatoes and press start. When done, wrap them in a clean cloth and leave aside for 10 min. Peel and use in curries, cutlets and other recipes where boiled potatoes are needed. Can be stored in refrigerator up to 3 days and used as required.</p>

Program 52 Idly

Number of serves: 2 Servings

Accessory



Recipe	Step 1
<p>Take a two plate idly steamer and grease the plates. Pour idly batter (room temperature) in the plates, filling the moulds up to $\frac{3}{4}$ levels.</p> <p>Expected total cooking time/3 min.</p>	<p>Pour $\frac{3}{4}$ cup of boiling hot water in the lower container of the steamer. Place the plates in it and cover with the lid. Keep in MWO and press start. When done, take it out. Let the idlies cool for 2-3 min. before removing from plates. Serve hot with chutney/sambar.</p>

Auto Menu

[5] Soup/Snack

Program 53 Soup Bread Cubes (H)

Accessory



Recipe	Step 1	Beep	Step 2
<p>Bread cubes 3 cups, heaped Oil 3 Tbsp Salt ½ tsp Chopped garlic 2 tsp, optional</p> <p>Expected total cooking time/6 min.</p>	<p>Cut 2-3 days old bread slices into 1.5 cm cubes to get 3 heaped cups of cubes. Toss them with oil, garlic and salt. Spread in a wide MW safe dish. Keep in MWO. Select the auto menu and press start.</p>	<p>Wait for beep (Beeping 3 min. after start)</p>	<p>After the beep stir well and press start. When done, let them cool completely, (during this time they will become crisp) Serve with soup or a light snack. * French loaf or bread cut in thick slices give better result in this recipe.</p>

(H) : Healthy Menu

Program 54 Dhokla

Number of serves: 3-4 Servings

Accessory



Recipe	Step 1
<p>Besan 1 cup Salt 1 tsp Sugar 1 tsp Citric acid 1 tsp Water ¾ cup Cooking Soda 1 tsp Very hot water ¼ cup Seasoning Oil 2 Tbsp Mustard seeds ½ tsp Cumin seeds ½ tsp Green chillies 2, slit Curry leaves few Hot water ⅓ cup</p> <p>Expected total cooking time/ 5 min. 30 sec.</p>	<p>Grease a 18-20 cm round MW safe round dish, cover the base with butter paper and grease the paper. Mix besan with salt, sugar and citric acid. Add water and mix till smooth. Dissolve soda in very hot water and add to the besan mixture. Mix well (the batter will rise rapidly) and pour in the greased dish. Place in MWO. Select the auto menu and press start. When done, cool the dhokla, turn out on a plate and cut into pieces. Prepare the seasoning (tadka), mix with hot water and pour evenly over the dhokla. Leave aside at least for 15-20 min. Serve garnished with grated coconut and coriander leaves.</p>

Auto Menu

[5] Soup/Snack

Program 55 Chilli Cheese Toast

Number of serves: 2 Servings

Accessory



Note: Usage of crispy plate or a flat aluminum/stainless steel plate by customer is recommended for better performance.

Recipe	Step 1	Beep	Step 2
Bread 4 slices (Standard size) Cheese spread 4 Tbsp Garlic 2 cloves, chopped Green chilli 1, chopped Cheddar/mozzarella cheese 4 tbsp, grated Expected total cooking time/ 5 min. 30 sec.	Crush the garlic and green chillies and mix with the cheese spread. Place the bread slices on crispy plate. Keep it on the high rack and place in MWO. Select the auto menu and press start.	Wait for beep (Beeping 3 min. 30 sec. after start)	After the beep, turn over the bread slices and apply cheese spread. Sprinkle 1 Tbsp of grated cheese on each slice. Return to the oven and press start. When done, serve hot.

Program 56 Pizza

Number of serves: 1 Serving

Accessory



Note: Usage of crispy plate or a flat aluminum/stainless steel plate by customer is recommended.

Recipe	Step 1	Beep	Step 2
Pizza base (store bought) 1 Pizza sauce 2 Tbsp Topping Cooked vegetables/Paneer/chicken Chopped onion and capsicum Pizza cheese 2-3 Tbsp, grated Oil to brush Expected total cooking time/5 min. (Excluding preheat time)	Grease the crispy plate with oil and place the pizzabase on it. Spread sauce on top, leaving 1 cm margin all round. Sprinkle cheese over the sauce. Arrange the cooked vegetable of your choice or paneer or cooked chicken over the cheese. Top with some chopped onion and capsicum. Brush the margin with oil and sprinkle some oil all over the topping. Press convection pad, and press Up/Down to set 200 °C for preheat, then press start. (The oven will preheat.)	Wait for beep (Beeping for preheat finish notice)	After the beep, place the crispy plate with pizza inside the MWO on high rack. Select the auto menu and press start. When done serve hot.

Auto Menu

[5] Soup/Snack

Program 57 Sausage

Number of serves: 2 Servings

Accessory



Note: Usage of crispy plate or a flat aluminum/stainless steel plate by customer is recommended for better performance.

Recipe	Step 1
Frozen sausages (store bought) 4 Expected total cooking time/8 min.	Take out the sausages from the freezer and let thaw according to the instructions on the pack. Brush the crispy plate with 1 Tbsp of oil. Place sausages on it and brush them with oil. Place the plate on the high rack and place in MWO. Select the auto menu and press start. When done, serve hot.

Program 58 Upma

Number of serves: 3 Servings

Accessory



Recipe	Step 1	Beep	Step 2
Water 500 ml Upma mix (store bought) 200 g Ghee/oil 1-2 Tbsp Expected total cooking time/7 min.	Pour the water in a MW safe 20-22 cm round dish. Place in MWO. Select the auto menu and press start.	Wait for beep (Beeping 5 min. after start)	After the beep add the upma mix and ghee. Mix well. Cover and return to MWO. Press start. When done serve hot garnished with coriander leaves.

Auto Menu

[5] Soup/Snack

Program 59 Aloo Poha

Number of serves: 3-4 Servings

Accessory



Recipe	Step 1	Beep	Step 2
Poha of medium thickness 2 cups Cooked potato cubes* 1 cup Turmeric powder ½ tsp Salt to taste Sugar to taste Oil 2 Tbsp Cloves 3 Cinnamon 2 pieces Onion ½ finely chopped Green chillies 2-3, chopped Curry leaves few Lime juice to taste Grated coconut ⅓ cup Coriander leaves 1 Tbsp, chopped * Auto menu - Cook Potato Expected total cooking time/9 min.	Soak poha in water till soft but not mushy. Gently squeeze out excess water and spread the poha on a wide plate. Mix it with potatoes, turmeric powder, salt and sugar. Combine all the ingredients from oil to curry leaves in a MW safe casserole (capacity not less than 2 L). Place in MWO and select the auto menu. Press start.	Wait for beep (Beeping 4 min. after start)	After the beep, add the poha mixture and mix well. Cover with a lid and return to the MWO. Press start. When done, add lime juice, grated coconut and coriander leaves. Mix well and serve hot.

Program 60 Spicy Corn

Number of serves: 4 Servings

Accessory



Recipe	Step 1	Beep	Step 2
Tomato puree ½ cup Maida 2 Tbsp Sugar ½ tsp Salt to taste Water 1 cup Cooked sweet corn kernels 1 cup Butter 3 Tbsp Onion ¼ cup, minced Garlic 2 tsp minced Chilli powder 1 tsp or to taste Kasoori Methi 1 tsp Fresh cream ¼ cup Expected total cooking time/10 min.	Mix tomato puree with Maida and stir till smooth. Add sugar, salt, water and sweet corn. Place the butter in a MW safe 18-20 cm round dish. Add onion, garlic, chilli powder and kasoori methi. Mix well and place inside the MWO. Select the auto menu and press start.	Wait for beep (Beeping 5 min. after start)	After the beep, add the corn mixture. Stir well and return to MWO and press start. When done, stir in the cream and serve hot on toast.

Auto Menu

[5] Soup/Snack

Program 61

Rawa Idly

Number of idlies: yield 8 idlies

Accessory



Recipe	Step 1
Rawa Idly mix 1 cup Curds 1 ½ cups Coriander leaves 2 tbsp, chopped Expected total cooking time/4 min.	Prepare the batter as per the instruction on the packet. Keep aside for 10 minutes. Grease the MW safe idly plates and fill with the batter. Pour ½-¾ cup of boiling hot water in the base of the idly steamer. Place the idly plates in it. Cover with the lid and keep in MWO. Select the auto menu and press start. When done, cool for 2 minutes. Remove from plates and serve hot with chutney.

Program 62

Instant Noodles

Number of serves: 1 Serving

Accessory



Recipe	Step 1	Beep	Step 2
Instant noodle packet 1 Water 250 ml Expected total cooking time/4 min.	Break the noodle slab into 2 pieces. Pour the water in a MW safe bowl (minimum capacity ½ L). Keep in MWO. Select the auto menu and press start.	Wait for beep (Beeping 1 min. 30 sec. after start)	After the beep, add the noodles and taste maker. Mix well and return to MWO. Press start. When done, let it stand for a couple of minutes, before serving.

Auto Menu

[6] Tandoori/Grill



- **Select desired category.**
The auto indicator lights and the program number 63 appears in the display.
- **Press Up/Down pad to select the suitable number in below chart.**
- **Press Start Pad.**

Program 63 **Paneer Tikka**
Number of serves: 4 Servings



Recipe	Step 1	Beep	Step 2
<p>Paneer 2 packets, 200 g each</p> <p>Curd ½ cup</p> <p>Ginger-garlic paste 1 Tbsp</p> <p>Chilli powder 1 tsp or to taste</p> <p>Garam masala 1 tsp</p> <p>Salt to taste</p> <p>Oil to brush</p> <p>Lime juice, garam masala/chaat masala to garnish</p> <p>Expected total cooking time/19 min.</p>	<p>Cut each block of paneer into 6 pieces. Beat the curds till smooth and mix with rest of the ingredients except the oil and garnish.</p> <p>Keep covered for 1-2 hours. Thread the pieces on thin metal skewers or bamboo skewers, piercing the pieces through their length. (If using bamboo skewers, soak them in water for 1 hour.)</p> <p>Brush the high rack with oil and place the skewers on it. Brush the pieces with oil.</p> <p>Keep the rack in MWO and place a heat proof glass/crockery plate below it to catch the drippings.</p> <p>Select the auto menu and press start.</p>	<p>Wait for beep (Beeping 11 min. after start)</p>	<p>After the beep, take out the rack, turn over the skewers and brush the pieces with oil. Return to oven, press start.</p> <p>When done, serve the tikkas hot, sprinkled with lime juice and garam masala/chaat masala. (optional)</p>

Auto Menu

[6] Tandoori/Grill

Program 64 Tandoori Chicken

Number of serves: 4 Servings

Accessory



Recipe	Step 1	Beep 1	Step 2
Chicken pieces 8 (800 g) Lime juice 4 Tbsp Salt 1 ½ tsp Curds 1 cup Ginger-garlic paste 2 Tbsp Chilli powder 2 tsp or to taste Tandoori chicken masala 2 tsp or to taste Tandoori food colour little, optional Oil to brush Salt, chilli powder and garam masala 1 tsp each for final coating Expected total cooking time/25 min. (Excluding preheat time)	Make deep cuts all over the chicken pieces. Add lime juice and salt. Mix well and keep aside for 10 minutes. Beat the curds till smooth and add rest of the ingredients from ginger-garlic paste to tandoori food colour. Pour over the chicken. Mix well keep covered for 3-4 hours at room temperature or longer in refrigerator. (If kept in refrigerator, take out at least 30 minutes before cooking.) Mix 1 tsp of each, salt, chilli powder and garam masala together. Pick up the pieces from the marinade and shake away the excess marinade, and toss in the masala mix. Place the chicken pieces on high rack and brush with oil. Press convection pad, and press Up/Down to set 200 °C for preheat, then press start. (The oven will preheat).	Wait for beep (Beeping for preheat finish notice)	After the beep, place the rack with the chicken in MWO. Place a heat proof glass/crockery plate below the rack to catch the drippings. Select the auto menu and press start.
		Beep 2	Step 3
		Wait for beep (Beeping 16 min. after start)	After the beep, turn over the pieces and brush with oil. Press start. When done, garnish with onion rings and lemon pieces and serve hot with mint chutney.

Auto Menu

[6] Tandoori/Grill

Program 65 Chicken Tikka

Number of serves: 4 Servings

Accessory

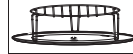

Recipe	Step 1
Bone less chicken breast 450-500 g Lime juice 2 Tbsp Salt to taste Curds 1 cup Ginger-garlic paste 1 Tbsp Tandoori chicken masala 2 Tbsp or to taste Kashmiri chilli powder 1 tsp Oil 2 Tbsp Tandoori food colour little, optional Extra oil to brush Lime juice, garam masala/chaat masala to garnish Expected total cooking time/29 min.	Cut the chicken into 2 cm cubes. Toss with lime juice and salt. Keep aside for 15 min. Beat the curd till smooth and mix with rest of the ingredients except the oil and garnish. Add to chicken and mix well. Cover and marinate for 4 hours or over night in refrigerator. (If refrigerated, take it out at least 30 min. before cooking.) Pick out the chicken pieces from the marinade and shake away the excess marinade. Thread the pieces on thin metal skewers or bamboo skewers. (If using bamboo skewers, soak them in water for 1 hour.) Brush the high rack with oil and place the skewers on it. Brush the pieces with oil. Place the rack in MWO and place a heat proof glass/crockery plate below it to catch the drippings. Select the auto menu and press start. When done, serve the tikkas hot, sprinkled with lime juice and garam masala/chaat masala. (optional)

Program 66 Fish Fry (H)

Number of serves: 4 Servings

Accessory



Note: Usage of crispy plate or a flat aluminum/stainless steel plate by customer is recommended.

Recipe	Step 1	Beep	Step 2
Use big flaky fish like king fish or Betki Fish slices 4, 1 cm thick (total weight 400 g approx.) Ginger-garlic paste 2 tsp Chilli powder 2 tsp or to taste Turmeric powder ½ tsp Coriander powder ½ tsp Salt to taste Egg white 1, lightly beaten Rice flour/corn flour to coat Oil to brush Expected total cooking time/10 min.	Wash the fish and wipe dry. Combine ginger-garlic paste with all the powders and mix with egg white. Apply to both sides of fish slices and leave aside for 15 min. Spread some rice flour or corn flour on a plate and press fish slices in it to coat both the sides. Line the crispy plate with aluminium foil and grease the foil very well with oil. Place the fish slices over it. Brush the slices with oil. Keep the plate on high rack in MWO. Select the auto menu and press start.	Wait for beep (Beeping 6 min. after start)	After the beep, carefully turn over the slices with a flat spatula. Brush with oil, return to MWO and press start. When done, leave aside for 5 min. and serve hot.

(H) : Healthy Menu

Auto Menu

[6] Tandoori/Grill

Program 67 Chicken Lollipop (H)

Number of serves: 4 Servings

Accessory



Recipe	Step 1	Beep	Step 2
Chicken lollipop 350-400 g Soya sauce 1 tsp Vinegar 2 tsp Ginger-garlic paste 2 tsp Chilli powder 1 tsp or to taste Sugar ½ tsp Salt to taste Ajinomoto ¼ tsp, optional Egg 1, lightly beaten Bread crumbs to coat Oil to brush Expected total cooking time/18 min. (Excluding preheat time)	Mix the chicken lollipops with Soya sauce, vinegar, ginger-garlic paste, chilli powder, sugar, salt and optional Ajinomoto. Keep aside for 1-2 hours. Lift the lollipops from the marinade. Coat with egg and bread crumbs and brush with oil. Place them on the high rack. Press convection pad, and press Up/Down to set 200 °C for preheat, then press start. (The oven will preheat.)	Wait for beep (Beeping for preheat finish notice)	Place the rack in MWO and place a heat proof glass/ crockery plate below it to catch the drippings. Select the auto menu and press start. When done, serve hot with chilli garlic sauce.

(H) : Healthy Menu

Program 68 Aloo Tikki (H)

Number of serves: 4 Servings

Accessory

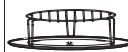

Note: Usage of crispy plate or a flat aluminum/stainless steel plate by customer is recommended.

Recipe	Step 1	Beep	Step 2
Cooked potato* 250 g Bread 2 slices, standard size Green chillies 2 or taste, minced Ginger ½ tsp, minced Coriander leaves 1 Tbsp, chopped Mint leaves 1 Tbsp, chopped Garam masala ½ tsp Chaat masala ½ tsp Salt to taste Oil to brush * Auto menu - Cook Potato Expected total cooking time/15 min.	Peel and mash the potato. Soak bread slices in water for 30 seconds. Squeeze out the water, mash the bread and add to potatoes. Add rest of the ingredients except the oil (Be careful with salt. Chaat masala is salty) Mix well and shape into 8 tikkis. Line the crispy plate with aluminium foil and brush the foil with oil. Place the tikkis over it. Brush the tikkis with oil. Keep the plate on high rack and place the rack inside the MWO. Select the auto menu and press start.	Wait for beep (Beeping 10 min. after start)	After the beep, turn over the tikkis and brush with oil. Return the rack to MWO and press start. When done, serve hot.

(H) : Healthy Menu

Auto Menu

[6] Tandoori/Grill

Program 69 BBQ Chicken (H)

Number of serves: 4 Servings

Accessory

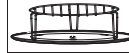

Recipe	Step 1	Beep	Step 2
Bone less chicken breast 400 g BBQ/HP sauce 1 ½ Tbsp Ginger-garlic paste 2 tsp Vinegar 1 Tbsp Curry powder 2 tsp or to taste Salt and pepper to taste Oil to brush Expected total cooking time/19 min.	Cut the chicken into 2 cm cubes. Add all the ingredients except the oil. Mix well and marinate for 3-4 hours or over night in refrigerator. (If left in refrigerator, take it out at least 30 minutes before cooking.) Soak 8 bamboo skewers in water for 1 hour. Lift out the chicken pieces from marinade and thread on the skewers. Brush the high rack with oil and place the skewers on it. Brush the pieces with oil. Keep the rack in MWO. Place a heat proof glass or porcelain plate below the rack to catch the drippings. Select the auto menu and press start.	Wait for beep (Beeping 16 min. after start)	After the beep, turn over the skewers and brush the chicken with oil. Return to MWO. Press start. When done, serve hot after 5 min.

(H) : Healthy Menu

Auto Menu

[6] Tandoori/Grill

Program 70 French Fries (H)

Number of serves: 4 Servings

Accessory



Note: Usage of crispy plate or a flat aluminum/stainless steel plate by customer is recommended for better performance.

Recipe	Step 1	Beep	Step 2
Potato 350 g Oil to brush Salt to taste Expected total cooking time/25 min.	Peel the potato and cut into fingers. Boil in water till 95% cooked. Strain and plunge in cold water for 5 min. Drain and press gently between two folds of cloth napkin to remove excess moisture. Line the crispy plate with aluminium foil. Brush the foil with oil. Spread the potato chips evenly on it. Brush them with oil and keep on high rack. Place the rack inside the MWO and press start.	Wait for beep (Beeping 15 min. after start)	After the beep, stir and return to oven. Press start. When done, let cool for 5 min. Sprinkle with salt and serve hot.

(H) : Healthy Menu

Auto Menu

[6] Tandoori/Grill

Program 71 Fish Cutlet (H)

Number of serves: 4 Servings

Accessory



Note: Usage of crispy plate or a flat aluminum/stainless steel plate by customer is recommended for better performance.

Recipe		Step 1	Beep	Step 2
Steamed fish*	250 g	Discard the skin and bones from fish and flake it. Add green chilies, ginger, garam masala, salt and coriander leaves. Peel and mash the potato and add to fish. Mix well. Divide into 8 parts and shape into cutlets. Dip in beaten egg and coat with bread crumbs. Line the crispy plate with aluminum foil and brush it with oil. Place the cutlets on it. Place the crispy plate on the rack and keep the rack in MWO. Select the auto menu and press start.	Wait for beep (Beeping 7 min. after start)	After the beep, turn over the cutlets and brush with oil. Return to MWO and press start. When done, serve hot.
Green chilies	2-3, minced			
Ginger	1 tsp, minced			
Garam masala	1 tsp			
Coriander leaves	2 Tbsp, chopped			
Salt to taste				
Cooked Potato**	150 g			
Egg and toasted bread crumbs to coat.				
Oil to brush				
* Auto menu - Steam Fish				
** Auto menu - Cook Potato				
Expected total cooking time/12 min.				

(H) : Healthy Menu

Program 72 Sheek Kabab

Number of serves: 3 Servings

Accessory



Note: Usage of crispy plate or a flat aluminum/stainless steel plate by customer is recommended.

Recipe	Step 1
Frozen Sheek Kababs (store bought) 250 g, approx.	Take out the kababs from the freezer and thaw as per the directions on the pack. Brush the crispy plate with 1 Tbsp of oil. Place 6 kababs (total wt 250 g approx.) on it and brush them with oil. Place the plate on the high rack and place in MWO. Select the auto menu and press start.
Expected total cooking time/10 min.	

Auto Menu

[7] Japanese



- **Select desired category.**
The auto indicator lights and the program number 73 appears in the display.
- **Press Up/Down pad to select the suitable number in below chart.**
- **Press Start Pad.**

Program 73 Yakitori Skewered Chicken

Number of serves: 4 Servings (12 skewers)

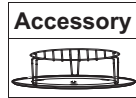

Recipe	Step 1
Chicken breast 600 g Bamboo skewer 12 Light Japanese soy sauce like Kikkoman (If not available, 1/8 cup of Indian saya sauce plus 1/8 cup water plus 1/2 tsp salt for the replacement.) 1/4 cup Orange juice 100 ml Ginger (chopped) 100 ml Garlic (chopped) 100 ml Brown sugar (or sugar) 2 tbsp Vegetable oil 1 tbsp Salt 1/2 tsp Expected total cooking time/29 min.	Cut chicken breast into 1.5-2 cm cube. Skewer 50 g each to bamboo skewers. Marinate the sauce over 1 hour. (need to turn over sometimes during marinate) Place on High rack. Place shallow dish under the rack to receive drip. Cook start.

Program 74 Chicken Teriyaki

Number of serves: 4 Servings (8 pieces)



Recipe	Step 1
Chicken pieces 8 pieces Light Japanese soy sauce like Kikkoman (If not available, 1/8 cup of Indian saya sauce plus 1/8 cup water plus 1/2 tsp salt for the replacement.) 1/4 cup Orange juice 100 ml Ginger (chopped) 100 ml Garlic (chopped) 100 ml Brown sugar (or sugar) 2 tbsp Vegetable oil 1 tbsp Salt 1/2 tsp Expected total cooking time/25 min.	Pierce the chicken skin with fork. Marinate the sauce over 1 hour. Place on Low rack, then place shallow dish under the rack to receive drip. Cook start.

Auto Menu

[7] Japanese

Program 75 Sukiyaki

Number of serves: 4 Servings

Accessory



Recipe	Step 1
Chicken fillets 400 g Tofu (bean curd) 100 g Dry shiitake mushrooms 4 * Soak dry shiitake mushrooms in water to soften. Chinese leeks 1 Chinese cabbage 200g Sauce Soup stock 200ml Light Japanese soy sauce like Kikkoman (If not available, 25 ml of Indian saya sauce plus 25 ml water plus 2 tsp salt for the replacement.) 50 ml Sugar 3 tbsp Expected total cooking time/33 min.	Cut the chicken bite-sized. Cut the tofu into large bite-sized pieces. Trim stems of dry shiitake mushrooms from them, and cut caps in half. Combine sauce ingredients in a bowl. Slice Chinese leeks diagonally. Cut Chinese cabbage into 3 cm lengths. Place all ingredients in casserole dish and pour sauce over them. Cover with lid, put on glass tray. Cook start.

Program 76 Marinated Chicken Nanban Style

Number of serves: 4 Servings

Accessory



Recipe	Step 1
Chicken thigh 500 g Onion 100 g Vegetable oil 1 tbsp Cornstarch 3 tbsp Nanban vinegar sauce Vinegar 100 ml Sugar 4 tbsp Light Japanese soy sauce like Kikkoman (If not available, 2 tbsp of Indian saya sauce plus 2 tbsp water plus 4 tsp salt for the replacement.) 4 tbsp Red pepper (remove seeds, cut into rounds) 1 Expected total cooking time/29 min.	Prepare Nanban vinegar sauce. Slice the onion thinly, soak onion slices in cold water for about 30 min. and drain well. Mix vinegar, sugar, soy sauce and red pepper. Cut the chicken thigh into joints. Add vegetable oil into chicken, and mix well. Dust the chicken with cornstarch. Place chicken with skin side up on High rack. Cook start. Let the cooked chicken soak in the Nanban vinegar sauce and let rest for more than an hour before serving.

Auto Menu

[7] Japanese

Program 77 Nikujaga

Number of serves: 4 Servings

Accessory



Recipe		Step 1
Chicken fillets (thigh)	200 g	Peel the potato, cut lengthwise into four wedges, soak in water for 10 min. Peel the onion, and cut lengthwise into four or six wedges. Cut the chicken bite-sized. Place all ingredients in a heat-resistant (microwavable) container, and mix well. Cover with lid, put on glass tray. Cook start.
Potato	450 g	
Onion	1 (200 g)	
Carrot	½ (100 g)	
Soup stock	300 ml	
Sugar	25 g	
Light Japanese soy sauce like Kikkoman (If not available, 2 tbsp of Indian saya sauce plus 2 tbsp water plus 4 tsp salt for the replacement.)	4 tbsp	
Expected total cooking time/41 min.		

Program 78 Kinpira

Number of serves: 4 Servings

Accessory



Recipe		Step 1
Celery	140 g	Cut the celery into 1 ½-inch-long strips. Peel the carrot, and thinly into strips of a similar size to that of the celery. Place all ingredients in casserole dish, mix well. Without cover, put on glass tray. Cook start.
Carrot	60 g	
Sugar	1 ½ tsp	
Light Japanese soy sauce like Kikkoman (If not available, 1 tbsp of Indian saya sauce plus 1 tbsp water plus 2 tsp salt for the replacement.)	2 tbsp	
Starch (katakuriko or cornstarch)	1 tsp	
Sesame oil	1 tsp	
White parched sesame	1 tsp	
Red pepper (as an option)	1	
Expected total cooking time/4 min.		

Auto Menu

[7] Japanese

Program 79 Simmered Pumpkin

Number of serves: 4 Servings

Accessory



Recipe	Step 1
Pumpkin 300 g Sugar 2 tbsp Light Japanese soy sauce like Kikkoman (If not available, 1 tbsp of Indian saya sauce for the replacement.) 2 tbsp Mirin (sweet cooking sake) 1 tbsp * if no mirin available, sugar (½ tbsp) can be replaced instead of mirin. Water 160ml Expected total cooking time/10 min.	Remove the pumpkin seeds and the fibers surrounding them with a spoon. Cut the pumpkin into bite-sized. (but still as large as possible) Place the sugar, soy sauce, mirin and water in a heat-resistant (microwavable) container. Mix well. Add the pumpkin in a container. Cover with lid, put on glass tray. Cook start.

Program 80 Simmered Chicken and Radish

Number of serves: 4 Servings

Accessory



Recipe	Step 1
Chicken pieces 500 g Giant white radish 400 g Soup stock (dashi) 300 ml Light Japanese soy sauce like Kikkoman (If not available, 1.5 tbsp of Indian saya sauce plus 1.5 tbsp water plus 3 tsp salt for the replacement.) 3 tbsp Sugar 1 tbsp Expected total cooking time/39 min.	Cut the giant white radish into about 2-3 cm half-moons, and bevel the edges. Place all ingredients in casserole dish. Cover with lid, put on glass tray. Cook start.

Auto Menu

[8] Dessert



- **Select desired category.**
The auto indicator lights and the program number 81 appears in the display.
- **Press Up/Down pad to select the suitable number in below chart.**
- **Press Start Pad.**

Program 81 Sooji Halwa

Number of serves: 4 Servings



Recipe	Step 1	Beep	Step 2
Lightly roasted sooji/rawa ½ cup Sugar ¾ cup Ghee 2 ½ Tbsp Water 1 ½ cups Cardamom powder ½ tsp Orange red food colour little, optional Fried cashew nuts and raisins to garnish Expected total cooking time/8 min.	Place all the ingredients except cashew nuts and raisins in a microwave safe 20-22 cm round dish. Mix well and place in MWO without cover. Select the auto menu and press start.	Wait for beep (Beeping 4 min. after start)	After the beep, stir very well and press start. When done, keep covered for 8-10 min. Mix in the cashew nuts and raisins. Serve warm or at room temperature.

Program 82 Carrot Halwa

Number of serves: 4-6 Servings



Recipe	Step 1	Beep	Step 2
Carrot, preferably pink 500 g Sugar ½ cup Sweet khova 200 g, crumbled Ghee 4 Tbsp Cardamom powder ½ tsp Nuts and raisins to garnish Expected total cooking time/15 min.	Peel and grate the carrots. Place in a wide MW safe dish. (22-25 cm) If using orange variety of carrots, sprinkle with 1 Tbsp of water. Cover with a lid. Keep in MWO. Select the auto menu and press start.	Wait for beep (Beeping 6 min. after start)	After the beep, add sugar, khova and ghee. Mix well and spread evenly in the dish. Return to MWO (do not cover). Press start. When done, leave without disturbing for 10 min. Stir in the cardamom powder and garnish with nuts and raisins. Serve warm or cold.

Auto Menu

[8] Dessert

Program 83 Rice Kheer

Number of serves: 3-4 Servings

Accessory



Recipe	Step 1	Beep	Step 2
<p>Basmati rice 3 Tbsp Milk 650 ml Condensed Milk ½ tin Cardamom powder ½ tsp Cashew nuts, almonds and raisins to garnish</p> <p>Expected total cooking time/27 min.</p>	<p>Wash the rice and soak in water for 30 min., Drain and place in a MW safe casserole (capacity not less than 1 ½ L) add milk (at room temperature). Do not cover. Place in MWO and press start.</p>	<p>Wait for beep (Beeping 7 min. after start)</p>	<p>After the beep, stir well and press start. When done, add condensed milk, cardamom powder, nuts and raisins. If the kheer is too thick, add some milk to adjust the thickness. Serve hot or cold.</p>

Program 84 Sweet Custard

Number of serves: 4 Servings

Accessory



Recipe	Step 1	Beep	Step 2
<p>Custard powder* 1 ½ Tbsp Milk 500 ml Sugar 3 Tbsp or to taste * Choose flavour of your choice</p> <p>Expected total cooking time/9 min.</p>	<p>Mix custard powder with ¼ cup of milk. Pour remaining milk in a MW safe casserole. (Minimum capacity 1 ½ L) keep it in MWO. (Do not cover) Select the auto menu and press start.</p>	<p>Wait for beep (Beeping 4 min. after start)</p>	<p>After the beep, add the custard powder and mix very well. Return to the MWO and press start. When done, add the sugar, mix well and keep covered till cold. Chill in refrigerator. Serve with fruit salad or other desserts as needed.</p>

Auto Menu

[8] Dessert

Program 85 Besan Laddoo

Number of yield: yield 15 laddoos

Accessory



Note: Usage of crispy plate or a flat aluminum/stainless steel plate by customer is recommended for better performance.

Recipe	Step 1	Beep	Step 2
Besan 100 g Wheat flour 100 g Powdered sugar 200 g Ghee 100 g (melted and cooled) Nutmeg powder ¼ tsp Roasted cashew nuts 2 Tbsp, very finely chopped Expected total cooking time/25 min.	Mix besan with wheat flour. Spread evenly on the crispy plate. Place on low rack in the MWO. Select the auto menu and press start.	Wait for beep (Beeping 14 min. after start)	After the beep, stir well and spread evenly. Press start. When done, cool it completely. Add rest of the ingredients and knead to form dough. Divide into 15 parts and shape into laddoos.

Program 86 Kesar Bath

Number of serves: 6-8 Servings

Accessory



Recipe	Step 1	Beep	Step 2
Basmati rice 1 cup Water 1 ½ cups Milk 1 ½ cups Sugar 1 ¼ -1 ½ cups Water 1 cup Saffron ¼ tsp Ghee ½ cup Raisins 3 tbsp Expected total cooking time/40 min.	Wash the rice, drain and soak in 1 ½ cups water and 1 ½ cups milk for 15 min. Mix the sugar with 1 cup of water. Soak saffron in 1 tsp of hot milk and crush. Place the rice with the soaking water and milk in a MW safe 2 L casserole. Keep it in MWO. Select the auto menu and press start.	Wait for beep (Beeping 25 min. after start)	After the beep add the sugar solution, ghee and raisins. Mix well and return to MWO. Press start. When done, keep covered for 10 min. Add the saffron and mix well. Serve warm.

Auto Menu

[8] Dessert

Program 87 Semiya Kheer

Number of serves: 4-6 Servings

Accessory



Recipe	Step 1	Beep	Step 2
<p>Milk 750 ml Roasted semiya*1 ½ cup Sugar ⅓ cup or to taste Cardamom powder ½ tsp Fried cashew nuts and raisins to taste *1 Use semiya which is marked "Roasted" or "Toasted"</p> <p>Expected total cooking time/20 min.</p>	<p>Pour the milk in a MW safe casserole. (Capacity not less than 2 L). Place in MWO (do not cover). Select the auto menu and press start.</p>	<p>Wait for beep (Beeping 10 min. after start)</p>	<p>After the beep, add semiya, mix very well and press start. When done, add sugar and cardamom powder. Mix well and garnish with nuts and raisins.</p>

Program 88 Carrot Kheer

Number of serves: 4-6 Servings

Accessory



Recipe	Step 1
<p>Carrot 150 g Milk 500 ml Condensed milk 4 Tbsp Sugar to taste if needed Badam milk masala 2 tsp Charoli seeds 2 Tbsp</p> <p>Expected total cooking time/14 min.</p>	<p>Peel and grate the carrots. Place in a MW safe Casserole. (minimum capacity 1 ½ L) Cover and keep in MWO. Select the auto menu and press start. When done, cool and blend till smooth, using some of the milk. Add remaining milk, condensed milk and badam milk masala. Add charoli. Serve chilled.</p>

Program 89 Qubani Ka Meeta

Number of serves: 6 Servings

Accessory



Recipe	Step 1	Beep	Step 2
<p>Dried Apricots 200 g Sugar ½ cup Blanched and sliced almonds few Fresh cream to serve</p> <p>Expected total cooking time/10 min.</p>	<p>Soak the apricots in 2 cups of water for 4-5 hours. Remove the seeds from apricots and return the fruit to the soaking liquid. Pour it in a 22 cm MW safe round dish. Cover with a lid and keep in the MWO. Select the auto menu and press start.</p>	<p>Wait for beep (Beeping 5 min. after start)</p>	<p>After the beep, add the sugar, mix well and return to the MWO (Do not cover) When done, cool and chill in refrigerator. Serve with fresh cream, topped with almond slices.</p>

Auto Menu

[8] Dessert

Program 90

Doodhi Halwa

Number of serves: 4 Servings

Accessory



Recipe	Step 1	Beep	Step 2
<p>Doodhi/Lauki 500 g, peeled and grated</p> <p>Sugar 150 g</p> <p>Ghee 3 Tbsp</p> <p>Cardamom powder ½ tsp</p> <p>Expected total cooking time/22 min.</p>	<p>Place the doodhi in a wide MW safe dish. Cover with a lid. Place in MWO. Select the auto menu and press start.</p>	<p>Wait for beep (Beeping 10 min. after start)</p>	<p>After the beep, add sugar and ghee. Mix well. Return to MWO. Do not cover. Press start. When done, cover and let stand for 10 min. Stir in the cardamom powder. Serve warm or cold.</p>

Program 91

Prashaad Halwa

Accessory



Recipe	Step 1	Beep	Step 2
<p>Rawa ½ cup, lightly roasted</p> <p>Sugar ½ cup</p> <p>Ghee ¼ cup</p> <p>Milk 1 ½ cups</p> <p>Ripe banana* ½ cup, minced</p> <p>* Slightly over ripe banana is good in this recipe. Chop it very finely so that it is almost mashed.</p> <p>Expected total cooking time/13 min.</p>	<p>Place the rawa in a MW safe casserole (Minimum capacity 1 ½ L). Add sugar, ghee and milk. Mix very well. Keep in MWO. Select the auto menu and press start.</p>	<p>Wait for beep (Beeping 4 min. after start)</p>	<p>After the beep, stir the mixture very well and return to MWO. Press start. When done, keep covered for 5 min. Mix in the bananas.</p>

Auto Menu

[9] Cake/Cookie



- **Select desired category.**
The auto indicator lights and the program number 92 appears in the display.
- **Press Up/Down pad to select the suitable number in below chart.**
- **Press Start Pad.**

Program 92 Brownies

Number of pieces: 12 pieces



Recipe	Step 1																
<table border="0"> <tr> <td>Melted butter</td> <td>½ cup</td> </tr> <tr> <td>Cocoa</td> <td>3 Tbsp</td> </tr> <tr> <td>Maida</td> <td>¾ cup</td> </tr> <tr> <td>Baking powder</td> <td>½ tsp</td> </tr> <tr> <td>Powdered/castor sugar</td> <td>1 cup</td> </tr> <tr> <td>Chopped walnuts</td> <td>4 Tbsp</td> </tr> <tr> <td>Eggs</td> <td>2</td> </tr> <tr> <td>Vanilla essence</td> <td>½ tsp</td> </tr> </table> <p>Expected total cooking time/6 min.</p>	Melted butter	½ cup	Cocoa	3 Tbsp	Maida	¾ cup	Baking powder	½ tsp	Powdered/castor sugar	1 cup	Chopped walnuts	4 Tbsp	Eggs	2	Vanilla essence	½ tsp	<p>Line the base of a MW safe 20 cm square dish with butter paper. Grease the paper and the sides of the dish. Mix cocoa with hot melted butter and leave aside to cool. Mix Maida with baking powder sugar and ½ the walnuts. Beat the eggs with vanilla essence and mix with the butter and cocoa. Add this mixture to the Maida and mix till combined. Pour in the prepared dish. Sprinkle remaining walnuts on top. Place the dish in the MWO. Select the auto menu and press start. When done, let it stand for 5 min. Leave the dish and to be cool completely. Turn out on a plate and cut into pieces.</p>
Melted butter	½ cup																
Cocoa	3 Tbsp																
Maida	¾ cup																
Baking powder	½ tsp																
Powdered/castor sugar	1 cup																
Chopped walnuts	4 Tbsp																
Eggs	2																
Vanilla essence	½ tsp																

Program 93 Eggless Chocolate Cake

Number of pieces: 8-10 pieces



Recipe	Step 1																
<table border="0"> <tr> <td>Maida</td> <td>1 ½ cups</td> </tr> <tr> <td>Powdered/castor sugar</td> <td>1 cup</td> </tr> <tr> <td>Baking soda</td> <td>1 tsp</td> </tr> <tr> <td>Cocoa</td> <td>3 Tbsp</td> </tr> <tr> <td>Oil</td> <td>5 Tbsp</td> </tr> <tr> <td>White vinegar</td> <td>1 Tbsp</td> </tr> <tr> <td>Milk</td> <td>1 cup</td> </tr> <tr> <td>Vanilla essence</td> <td>1 tsp</td> </tr> </table> <p>Expected total cooking time/5 min.</p>	Maida	1 ½ cups	Powdered/castor sugar	1 cup	Baking soda	1 tsp	Cocoa	3 Tbsp	Oil	5 Tbsp	White vinegar	1 Tbsp	Milk	1 cup	Vanilla essence	1 tsp	<p>Line the base of a 20-22 cm MW safe round dish with butter paper and grease the paper and the sides of the dish. Mix Maida, sugar, soda and cocoa together. Combine oil with vinegar, milk and vanilla essence. Add it to the Maida sugar mixture and mix till smooth. Pour in the dish. Keep the dish in MWO. Select the auto menu and press start. When done let it stand for 5 min. Leave the dish and to be cool completely. Turn out on a plate and serve cut into pieces. (The cake may be sprinkled with icing sugar after cooling, if desired.)</p>
Maida	1 ½ cups																
Powdered/castor sugar	1 cup																
Baking soda	1 tsp																
Cocoa	3 Tbsp																
Oil	5 Tbsp																
White vinegar	1 Tbsp																
Milk	1 cup																
Vanilla essence	1 tsp																

Auto Menu

[9] Cake/Cookie

Program 94 Orange Cake (with cinnamon on top)

Number of pieces: 8-10 pieces

Accessory



Recipe		Step 1
Maida	1 cup	Grease a MW safe 20-22 cm cake dish and line the base with greased butter paper. Mix Maida with baking powder. Beat butter till soft. Add sugar, eggs and orange rind and beat till very smooth and light. Add Maida alternately with orange juice and mix lightly. Pour the mixture into the prepared dish. Mix the sugar for topping with cinnamon and sprinkle on top. Place in MWO. Select the auto menu and press start. When done, leave without disturbing for 10 min. (The edges of the cake may look slightly moist but will dry up during the standing time.) Leave the dish and to be cool completely. Turn out on a plate and serve cut into pieces.
Baking powder	1 tsp	
Butter	¼ cup	
Powdered Sugar	¾ cup	
Eggs	2	
Orange rind	2 tsp	
Orange juice (no added sugar)	100 ml	
Topping		
Powdered sugar	2 Tbsp	
Cinnamon powder	2 tsp	
Expected total cooking time/7 min.		

Program 95 Butter Cake

Number of pieces: 8-10 pieces

Accessory



Recipe		Step 1	Beep	Step 2
BreMaida	1 ½ cups	Grease a 20-22 cm round cake tin and line it with butter paper. Grease the paper. Mix Maida with baking powder and salt. Beat sugar and butter till fluffy. Add eggs one by one, beating well after each addition. Beat in the essence. Fold in the Maida and milk. Pour the mixture in the tin. Press convection pad, and press Up/Down to set 180 °C for preheat, then press start. (The oven will preheat.)	Wait for beep (Beeping for preheat finish notice)	After the beep, place the tin on low rack in MWO. Select the auto menu and press start. When done, turn out the cake after 10 min. Cool completely before cutting into pieces. Note: If the cake browns before cooking time, place a piece of aluminium foil on top of the tin and press start.
Baking powder	1 ½ tsp			
Salt	¼ tsp			
Powdered sugar	¾ cup			
Butter	¾ cup			
Eggs	3			
Vanilla essence	1 tsp			
Milk	2 Tbsp			
Expected total cooking time/35 min. (Excluding preheat time)				

Auto Menu

[9] Cake/Cookie

Program 96 Raisin Muffins

Number of pieces: 6 pieces

Accessory



Recipe	Step 1	Beep	Step 2
<p>Maida 1 cup Raisins ¼ cup Baking powder 1 tsp Butter ¼ cup Brown sugar ½ cup Egg 1 Vanilla essence ½ tsp Cinnamon powder 1 tsp Curd ¼ cup, beaten till smooth</p> <p>Expected total cooking time/18 min. (Excluding preheat time)</p>	<p>Grease 6 large muffin cups with butter. Mix Maida with baking powder and stir in the raisins. Beat butter, sugar and egg together till light. Beat in vanilla essence and cinnamon powder. Gently mix in the Maida mixture alternately with curds. Pour the butter in the prepared cups. Press convection pad, and press Up/Down to set 180 °C for preheat, then press start. (The oven will preheat.)</p>	<p>Wait for beep (Beeping for preheat finish notice)</p>	<p>After the beep, place the cups on the low rack in MWO. Select the auto menu and press start. When the muffins are golden brown on top, cover lightly with foil. Press start. When done, cool the muffins for 10 minutes. Turn out the muffins from cups and serve warm or cool completely and store in container.</p>

Program 97 Fruit Cake

Accessory



Recipe	Step 1	Beep	Step 2
<p>Maida 2 cups Baking powder 2 tsp Salt ¼ tsp Dry fruits and nuts 1 cup, chopped Butter ½ cup Powdered sugar ½ cup Eggs 2 Orange essence 1 tsp Milk ⅓ cup (80 ml)</p> <p>Expected total cooking time/40 min. (Excluding preheat time)</p>	<p>Grease a 22 cm cake tin and line the base with butter paper. Grease the paper. Mix Maida with baking powder and salt. Add the fruits and mix well. Beat butter, sugar and eggs together till light and fluffy. Add the essence. Gently mix in the Maida alternately with milk. Pour the mixture in the prepared tin. Press mixture. Press convection pad, and press Up/Down to set 170 °C for preheat, then press start. (The oven will preheat.)</p>	<p>Wait for beep (Beeping for preheat finish notice)</p>	<p>After the beep, keep the tin in MWO on the low rack. Select the auto menu and press start. When the top of the cake is golden brown, cover the tin lightly with aluminium foil. Press start. When done, cool the cake on a rack for 10 min. Turn it out of the tin and cool completely before slicing and serving.</p>

Auto Menu

[9] Cake/Cookie

Program 98 Coconut Cake

Accessory



Recipe	Step 1	Beep	Step 2
Milk 250 ml Sugar 300 g Butter 100 g Rawa 250 g Desiccated coconut 200 g Eggs 4, separated Baking powder 1 tsp Vanilla essence 1 tsp Expected total cooking time/50 min. (Excluding preheat time)	Grease a 22 cm cake tin. Line the base with butter paper and grease the paper. Boil the milk. Add sugar, stir till dissolved. Add butter and rawa. Mix well and leave aside to cool. When the mixture is cool, add desiccated coconut. Beat in the egg yolks. Add baking powder and vanilla and mix. Beat the egg whites stiffly and gently mix into the cake mixture. Pour the mixture in the prepared tin. Press convection pad, and press Up/Down to set 180 °C for preheat, then press start. (The oven will pre preheat.)	Wait for beep (Beeping for preheat finish notice)	After the beep, place the tin over the low rack in the MWO. Select the auto menu and press start. When the cake is golden brown on top, cover the tin lightly with aluminium foil. When done, leave the cake on a wire rack to cool for 15-20 min. Turn out the cake and cool completely before slicing.

Program 99 Nan Khathai

Number of Nan Khatais: yields 16 Nan Khatais

Accessory



Note: Usage of crispy plate or a flat aluminum/stainless steel plate by customer is recommended for better performance.

Recipe	Step 1
Maida 1 ½ cups Baking soda ¼ tsp Ghee ¾ cup Sugar ½ cup Cardamom powder ½ tsp Expected total cooking time/22 min.	Mix Maida with soda. Beat the butter with ghee till light. Add cardamom powder and saffron/colour. Add Maida and knead lightly till the mixture binds together. (If the mixture is sticky, keep covered in refrigerator for 15 min. till it is like soft dough. Divide the mixture into 16 parts. Shape 8 parts into rounds and flatten slightly. Line the base of crispy plate with foil and grease the foil. Place the shaped nan khathais on it. Mark a cross with a knife on each Nan khatai. Place the crispy plate on low rack and keep inside the MWO. Select the auto menu and press start. When done, repeat with remaining mixture. Cool the nan khatais completely and store in air tight container.

Auto Menu

[9] Cake/Cookie

Program 100 Pista Biscuits

Number of pieces: 25 pieces

Accessory



Note: Usage of crispy plate or a flat aluminum/stainless steel plate by customer is recommended for better performance.

Recipe	Step 1
<p>Ghee ¼ cup Powdered sugar ¼ cup Badam milk masala 2 tsp Maida 1 cup Pista 4 Tbsp, blanched and sliced thinly</p> <p>Expected total cooking time/15 min.</p>	<p>Beat ghee and sugar together till light. Add milk masala and beat. Add maida and knead lightly to form dough. (If the dough is crumbly, add few drops of milk. If it is sticky, keep covered in refrigerator for 15-20 min.) Roll out the dough to ¼ cm thick sheet. Sprinkle pista on top and press down gently to make it stick. Cut the sheet with a 4 cm round biscuit cutter. Collect the excess dough, roll and cut again. Line the crispy plate with aluminium foil. Grease the foil and arrange ½ the biscuits on it. Place the plate on low rack in MWO. Select the auto menu and press start. When done, repeat with remaining biscuits. Cool completely and store in air tight container.</p>

Program 101 Cherry Biscuits

Number of pieces: Yield 14 pieces

Accessory



Note: Usage of crispy plate or a flat aluminum/stainless steel plate by customer is recommended for better performance.

Recipe	Step 1
<p>Maida 1 cup Soda ¼ tsp Glazed cherries 2 Tbsp, chopped Butter ½ cup Powdered sugar ½ cup Rose essence ¼ tsp</p> <p>Expected total cooking time/18 min.</p>	<p>Mix together the Maida, soda and cherries. Beat butter and sugar together till light. Add essence and Maida mixture. Roll out to ¼ cm thickness and cut with a 5 cm long oval cutter. Line the crispy plate with aluminium foil and grease it. Place ½ the cookies on it. Place the plate on low rack and keep in MWO. Select the auto menu and press start. When done, repeat with remaining cookies. Cool the cookies completely and store in air tight container.</p>

Questions and Answers

- Q:** Why won't my oven turn on?
- A:** When the oven does not turn on, check the following:
1. Is the oven plugged in securely? Remove the plug from the outlet, wait 10 seconds and reinsert.
 2. Check the circuit breaker and the fuse. Reset the circuit breaker or replace the fuse if it is tripped or blown.
 3. If the circuit breaker or fuse is all right, plug another appliance into the outlet. If the other appliance works, there probably is a problem with the oven. If the other appliance does not work, there probably is a problem with the outlet.
If it seems that there is a problem with the oven, contact an authorized Service Center.
- Q:** My microwave oven causes interference with my TV. Is this normal?
- A:** Some radio and TV interference might occur when you cook with the microwave oven. This interference is similar to the interference caused by small appliances such as mixers, vacuums, blow dryers, etc. It does not indicate a problem with your oven.
- Q:** The oven won't accept my program. Why?
- A:** The oven is designed not to accept an incorrect program. For example, the oven will not accept a third stage.
- Q:** Why does my oven light dim?
- A:** When cooking with a power other than 900 W (MAX Power), the oven must cycle to obtain the lower power levels. The oven light dims and clicking noises can be heard when the oven cycles.
- Q:** Sometimes warm air comes from the oven vents. Why?
- A:** The heat given off from the cooking food warms the air in the oven cavity. This warmed air is carried out of the oven by the air flow pattern in the oven. There are no microwaves in the air. The oven vents should never be blocked during cooking.
- Q:** Can I use a conventional oven thermometer in the oven?
- A:** Only when you are using GRILL and CONVECTION cooking mode. The metal in some thermometers may cause arcing in your oven and should not be used on MICROWAVE and COMBINATION cooking modes.
- Q:** There are humming and clicking noises from my oven when I cook by COMBINATION. What is causing these noises?
- A:** The noises occur as the oven automatically switches from MICROWAVE power to GRILL or CONVECTION to create the combination setting. This is normal.

Care of Your Oven

1. Turn the oven off before cleaning, and wait until inside oven cavity is cooled down to avoid burnt. Heating devices inside oven on top and back may be still hot.
2. Keep the inside of the oven, door seals and door seal areas clean. When food splatters spilled liquids adhere to the oven walls, or door seals and door seal areas wipe off with a damp cloth. Mild detergent may be used if they get very dirty. The use of harsh detergent or abrasive is not recommended.
DO NOT USE COMMERCIAL OVEN CLEANERS.
3. The outside oven surface should be cleaned with a damp cloth. To prevent damage to the operating parts inside the oven, water should not be allowed to seep into the ventilation openings.
4. If the Control Panel becomes dirty, clean it with a soft, dry cloth. Do not use harsh detergents or abrasives on the Control Panel. When cleaning the Control Panel leave the oven door open to prevent the oven from accidentally turning on. After cleaning touch **Stop/Reset** Pad to clear display window.
5. If steam accumulates inside or around the outside of the oven door, wipe with a soft cloth. This may occur when the microwave oven is operated under high humidity conditions and in no way indicates a malfunction of the unit.
6. It is occasionally necessary to remove the glass tray for cleaning. Wash the tray in warm soapy water or in a dishwasher.
7. The roller ring and oven cavity floor should be cleaned regularly to avoid excessive noise. Simply wipe the bottom surface of the oven with mild detergent and hot water then dry with a clean cloth. The roller ring may be washed in mild soapy water. Cooking vapours collect during repeated use but in no way affects the bottom surface or roller ring wheels. After removing the roller ring from the cavity floor for cleaning, be sure to replace it in the proper position.
8. When using the GRILL, CONVECTION or COMBINATION mode, some foods may inevitably splatter grease onto the oven walls. If the oven is not cleaned occasionally, it may start to "smoke" during use.
9. A steam cleaner is not to be used for cleaning.
10. This oven should only be serviced by qualified personnel. For maintenance and repair of the oven contact the nearest authorized dealer.
11. Keep air vents clear at all times. Check that no dust or other material is blocking any of the air vents on the top, bottom or rear of the oven. If air vents become blocked this could cause overheating which would affect the operation of the oven and possibly result in a hazardous situation.
12. Do not use harsh abrasive cleaners or sharp metal scrapers to clean the oven door glass since they can scratch the surface, which may result in shattering of the glass.

Technical Specifications

Power Source:	240 V	50 Hz
Power Consumption:	Maximum;	1450 W
	Microwave;	1450 W
	Grill;	1400 W
	Convection;	2400 W
	Combination;	2400 W
Output:	Microwave;	900 W (IEC-60705)
	Top Heater;	1400 W
	Back Heater;	1000 W
Outside Dimensions:	513 (W) x 471 (D) x 306 (H) mm	
Oven Cavity Dimensions:	330 (W) x 348 (D) x 239 (H) mm	
Uncrated Weight:	17.2 kg	



Information on Disposal for Users of Waste Electrical & Electronic Equipment (private households)

This symbol on the products and/or accompanying documents means that used electrical and electronic products should not be mixed with general household waste.

For proper treatment, recovery and recycling, please take these products to designated collection points, where they will be accepted on a free of charge basis.

Alternatively, in some countries you may be able to return your products to your local retailer upon the purchase of an equivalent new product.

Disposing of this product correctly will help to save valuable resources and prevent any potential negative effects on human health and the environment which could otherwise arise from inappropriate waste handling. Please contact your local authority for further details of your nearest designated collection point.

Penalties may be applicable for incorrect disposal of this waste, in accordance with national legislation.

Panasonic Corporation

Web Site: <http://panasonic.com.net>