

## Owner's operation & installation manual

CO<sub>2</sub> HEAT PUMP  
HOT WATER SYSTEM

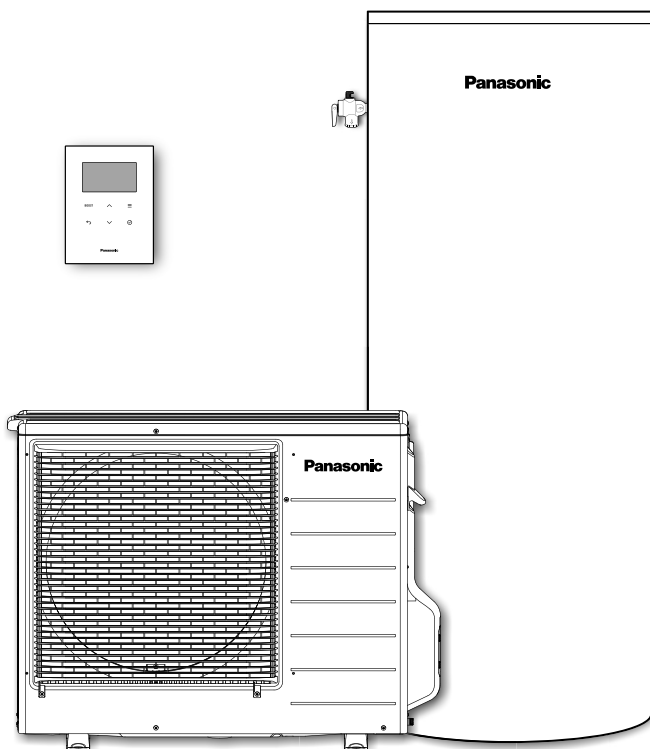

### COVERING MODEL NUMBERS

#### CO<sub>2</sub> HEAT PUMP UNIT

- 6 kW (heat output)

**HE-UM60CR**

- 4 kW (heat output)

**HE-UM40CR**

#### CONTROLLER (sold separately)

- Wireless LAN module built-in

**HE-1MAHR**

#### TANK UNIT (sold separately)

- Selecting of tank capacity options

**HE-TM400AHR** (400 L option)

**HE-TM315AHR** (315 L option)

**HE-TM250AHR** (250 L option)

Contents	Page
Safety Precautions	2
Owner's operation manual	9
Maintenance	27
Troubleshooting	34
Installation manual	38
Specifications	64
Using "Panasonic Comfort Cloud" app	69
Copyrights ,etc. (OSS)	81
Warranty policy	93
Helpdesks	Back cover

Thank you for purchasing Panasonic CO<sub>2</sub> HEAT PUMP HOT WATER SYSTEM

Before operating the unit, please read the operation & installation manual thoroughly, and especially "Safety Precautions" (refer to P.2-7) for the first time, and keep them for future reference.

Before installation, the installer must read these manuals, then request the customer keep them for future reference.





# Safety Precautions

To prevent personal injury, injury to others or property damage, please comply with the following:

Incorrect operation due to failure to follow instructions below may cause harm or damage, the seriousness of which is classified as below:



This appliance is not intended for accessibility by the general public.





 <b>DANGER</b>	This sign warns of death or serious injury due to explosion.
---	--

 <b>WARNING</b>	This sign warns of death or serious injury.
--	---

 <b>CAUTION</b>	This sign warns of injury or damage to property.
--	--

The instructions to be followed are classified by the following symbols:

  	This symbol denotes an action that is PROHIBITED.
---	---

   	These symbols denote actions COMPULSORY.
---	--



## DANGER

For users / General

-  **Must do**
  - Failure to operate the relief valve easing gear at least once every six months may result in the water heater exploding.
  - Continuous leakage of water from the valve may indicate a problem with the water heater.

## WARNING

For users / General

-  **Must do**
  - This appliance is not intended for use by persons (including children) with reduced physical, sensory or mental capabilities, or lack of experience and knowledge, unless they have been given supervision or instruction concerning use of the appliance by a person responsible for their safety.
  - Children should be supervised to ensure that they do not play with the appliance.
  - This appliance may deliver water at high temperature. Refer to the Plumbing Code of Australia (PCA), local requirements and installation instructions to determine if additional delivery temperature control is required. (Failure to do so may result in accidents or burns.)
  - This system contains high-pressure refrigerant and should only be serviced by qualified personnel. (Failure to do so may result in accidents or malfunctions.)
-  **Don't do**
  - Do not disassemble, repair, modify, or relocate the unit. (Doing so may cause electric shock, fire, scald or injury.) Contact your retailer for any repairs or relocation.
-  **Must do**
  - The valve or drain valve outlet pipe must not be sealed or blocked.
  - For continued safety of this appliance it must be installed, operated and maintained in accordance with the manufacturer's instructions.
  - After installation, relocation, or servicing of the refrigerant system, have your retailer or qualified technician confirm the following:
    - The specified refrigerant is used. (Use of non-specified refrigerant may cause equipment failure, rupture, or injury.)
  - This appliance can be used by children aged from 8 years and above and persons with reduced physical, sensory or mental capabilities or lack of experience and knowledge if they have been given supervision or instruction concerning use of the appliance in a safe way and understand the hazards involved.



# WARNING

## For users

### / General



Don't do

- Children shall not play with the appliance. Cleaning and user maintenance shall not be made by children without supervision.
- Do not continue to use hot water from the tank unit with the power off. If the unit will be powered off for an extended period, drain the water from the system. (Failure to do so may result in accidents due to Legionella bacteria.)



Must do

- If the system will not be used for an extended period, turn off the power to both the tank unit and heat pump unit, and drain the water. (Failure to do so may cause highly flammable hydrogen gas to accumulate in the tank, potentially leading to an explosion.)
- If the system is unused for two weeks or more, highly flammable hydrogen gas may accumulate in the tank. For safety, open the relief valve and release all gas. During this procedure, do not plug or unplug power cords, operate other electrical appliances, smoke, or handle open flames near the hot water area.

## For users

### / Fire, electric shock



Don't do

- Do not place gas cylinders or flammable materials nearby. (Sparks from electrical components may ignite them and cause fire.)

- Do not open the cover of the CO<sub>2</sub> heat pump unit. (Doing so may cause electric shock.)



Don't do

- Do not use modified cords, connection cables, extension cords, or unspecified cables. (To prevent overheating, fire, or smoke damage.)

- To prevent overheating, fire, or electric shock, observe the following precautions:
  - Do not share the power outlet with other appliances
  - Do not operate with wet hands
  - Do not excessively bend the power cord
  - Do not turn the CO<sub>2</sub> heat pump unit on or off by plugging/unplugging the power plug
  - Insert the power plug securely
  - Wipe dust from the power plug regularly with a dry cloth

## For users

### / Fire, electric shock



Must do

- If the supply cord is damaged, it must be replaced by the manufacturer, its service agent or similarly qualified persons in order to avoid a hazard.

- The CO<sub>2</sub> heat pump unit must be earthed to prevent electric shock or fire.

- To prevent electric shock, turn off the power and unplug the unit in the following cases:
  - Before cleaning, repairs, or maintenance
  - During severe thunderstorms

- When a plug is deemed to be removed, it must be clearly visible from any points he/she can access that the plug remains removed.

- If any abnormality or malfunction occurs, stop using the product and turn off the power immediately. Contact your retailer promptly for maintenance or repair. (To prevent overheating, fire, smoke, or electric shock.)

Examples of abnormalities or malfunctions:

- The earth leakage circuit breaker trips frequently
- A burning smell is present
- Unusual noise or vibration from the CO<sub>2</sub> heat pump unit
- Water leaking from the piping
- Power cord or plug becomes abnormally hot

## For users

### / Scald



Must do

- Always check the hot water temperature before use. (To prevent burns.)

- When using a mixing faucet or shower, test the water temperature with your hand.

- At the beginning of use, avoid touching the hot water. (Hot water mixed with air may spray out and cause burns.)

Be especially cautious when using the unit for the first time in the morning.

- Do not touch hot water or hot parts. (May cause burns.)

- Avoid touching the hot water supply tap during use.



Don't do

# Safety Precautions (Continued)



## WARNING

For users

/ Injury



Don't do

- **Do not mishandle the heat pump unit:**
  - Do not insert fingers or objects into the air outlet of the CO<sub>2</sub> heat pump unit. (The fan rotates at high speed and may cause injury.)
  - Do not step on or place objects on top of the unit. (If installed on a balcony or elevated surface, this may cause injury from falling or tipping.)



## CAUTION

For users

/ General



Must do

- **This appliance must be installed by the sales dealer or installer.**
- **Select an installation location which is rigid and strong enough to support or hold the unit, and select a location for easy maintenance.**
- **After Installation, Check the Following:**
  - The tank unit is installed on a designated base. (Failure to do so may result in injury due to tipping.)
  - The tank unit is installed on a waterproof and properly drained surface. (Water leakage may cause damage to the floor below.)
  - The pipe insulation is properly installed. (If not, freezing in winter may cause pipe damage, burns, or water leakage.) If there are any issues with the installation, contact your dealer to confirm the work and request corrective measures.
- **If the system will not be used for an extended period, drain water from both the tank unit and the CO<sub>2</sub> heat pump unit.** (Failure to do so may result in water quality changes that could affect your health.)
- **When draining water from the tank unit: Mix the hot water with cold water to lower the temperature before draining. Do not discharge boiling water directly.** (This may cause burns or damage to the drainage piping.)
- **Carefully handle the liquid refrigerant, as it may cause a frostbite.**



## CAUTION

For users

/ General



Don't do

- **In case of malfunction of this appliance, do not repair by yourself in order to prevent electrical, mechanical and other risks. Contact the sales dealer or service dealer for a repair.**

For users

/ Mounting



Must do

- **During maintenance or inspection:**
  - Turn off the power. (The fan of the CO<sub>2</sub> heat pump unit rotates at high speed and may cause injury.)
  - Regularly check the operation of the relief valve. (If the valve does not operate properly, it may cause water leakage.) If it does not function, contact your dealer.
- **The water can drip from the discharge pipe of the pressure-relief device and that this pipe must be left open to the atmosphere.**
- **The pressure-relief device is to be operated regularly to remove lime deposits and to verify that it is not blocked.**
- **Do not touch the aluminum parts of the CO<sub>2</sub> heat pump unit.** (This may cause cuts.)
- **Do not apply excessive force to the piping.** (This may cause breakage, resulting in burns or water leakage.)
- **If the base of the CO<sub>2</sub> heat pump unit is damaged, do not leave it as is.** (This may result in injury due to tipping or falling.)
- **Do not wash the water heater with water.** (This may cause fire, smoke, or electric shock due to short-circuiting.)
- **When freezing conditions are expected, do not turn off the power to the water heater.** (Freezing may cause pipe breakage and result in water leakage.)



Don't do



## CAUTION

### For users

### / Mounting



Don't do

- **Do not drink the hot water directly from the water heater. Over time, scale may build up inside the tank unit, and degradation of piping materials may affect water quality.**

If you wish to use the hot water for drinking, be sure to follow these precautions and boil the water once before consumption:

- Use water that meets drinking water quality standards.
- Do not use the stagnant water (water remaining in pipes) as drinking water; use it for non-drinking purposes.
- If you notice solid matter, discoloration, cloudiness, or an unusual odor, do not drink the water and request an inspection immediately.

### For users

### / Connecting to a wireless LAN



Don't do

- **Do not place medical or automatic control devices (such as automatic doors or fire alarms) near the controller while connected to wireless LAN.**

(The radio waves from the controller may interfere with these devices, potentially causing malfunction.)

- **If you have a cardiac pacemaker, keep it at least 15 cm away from the controller.** (Radio waves from the controller may cause malfunction.)



Must do

- **To avoid malfunctions caused by radio wave interference, keep the product away from other wireless devices, microwave ovens, or devices using the 2.4 GHz frequency when the wireless LAN module is in use.**

- The wireless LAN module may not be available in some regions.

- **Do not disassemble or modify the wireless LAN module built into the controller.**



Don't do



Must do

- **When operating remotely, you cannot check whether someone is using the bath or hot water (shower or tap). Remote operation may become unavailable due to communication issues, network conditions, or system failures (e.g., Panasonic Cloud server downtime, ISP server issues, Wi-Fi problems). This may result in serious injury, death, or property damage. Always ensure safety before performing remote operations.**

### For users

### / Connecting to a wireless LAN



Must do

- **Before using remote operation, check the following:**

- Ensure no one is using hot water.
- Confirm the controller settings.
- Ensure there are no abnormalities with the controller, tank unit, or CO<sub>2</sub> heat pump unit.



Don't do

- **Do not use remote operation in situations where safety or property security depends on it.**

- If there is any risk to safety or property, operate the system directly via the controller.
- Do not use remote operation when only infants, elderly persons, or people with physical disabilities (who cannot operate the remote themselves) are at home.



Must do

- **If you know that someone is at home, inform them before remotely changing the water heater or controller settings.**

(Sudden changes in hot water temperature may affect their health.)

- **While operating remotely, frequently check the controller settings and system status.**

(Sudden changes in hot water temperature may affect health.)

- **If the main display of the Panasonic Comfort Cloud app does not reflect the correct water heater settings, operate the water heater using the controller.**

- **If an error code is displayed, stop remote operation immediately and contact your dealer for maintenance or repair.**

### For users

### / Operating the controller



Must do

- **The controller is only to be used with the CO<sub>2</sub>HPU terminal block power supply.**

# Safety Precautions (Continued)



## WARNING

### For construction



Must do

- **This appliance is not intended for use by persons (including children) with reduced physical, sensory, or mental capabilities, or lack of experience or knowledge, unless they have been given supervision or instruction concerning the use of the appliance by a person responsible for their safety. Children should be supervised to ensure they do not play with the appliance.**
- **This system contains high-pressure refrigerant and must only be serviced by qualified personnel.**  
(Improper servicing may result in accidents or malfunction.)
- **This appliance may supply high-temperature hot water.**  
Refer to Australian Plumbing Code (PCA), local regulations, and installation instructions to determine if additional temperature control is required.  
(Failure to do so may result in burns or accidents.)
- **Piping work connected directly to the water supply must be performed using specified materials by a licensed plumber approved by the local authority (water utility).**  
(Failure to do so may result in accidents or malfunctions.)
- **The discharge pipe connected to the pressure-relief device is to be installed in a continuously downward direction and in a frost-free environment**
- **If the water supply pressure exceeds the rated pressure, a pressure reducing valve is to be fitted in the installation.**
- **Use a dedicated residual current device (RCD).**  
(Using a shared circuit with other appliances may cause overheating and fire.)
- **During test operation, check the function of the RCD.**  
(If the RCD does not operate correctly, it may cause electrical accidents or malfunctions.)
- **Install the water heater in a location that can withstand its full weight when filled with water.**  
(Installation on inadequate surfaces may result in tipping or falling accidents.)



Don't do



Must do



Don't do



Must do

- **Do not install the unit near gas cylinders or flammable materials.**  
(Doing so may result in accidents or malfunction.)
- **Do not install the CO<sub>2</sub> heat pump unit indoors.**  
(If refrigerant leaks, it may lead to oxygen deficiency.)
- **Do not install the CO<sub>2</sub> heat pump unit near balcony railings.**  
(Children may climb the unit and fall over the railing.)
- **When performing electrical wiring work, do not extend power cables, use stranded wires, or modify the connection ends. Use the specified cable.**  
(Improper wiring may cause malfunction or fire due to overheating.)
- **Do not use modified power cords, connection cables, extension cords, or any cables not specified for use with this product.**  
(This is to prevent overheating, fire, or smoke-related hazards.)
- **To prevent overheating, fire, or electric shock, observe the following precautions:**
  - Do not share the same power outlet with other equipment.
  - Do not operate with wet hands.
  - Do not excessively bend the power cord.
  - Do not start or stop the CO<sub>2</sub> heat pump unit by plugging in or unplugging the power cord.
  - Insert the power plug correctly and fully.
  - Regularly wipe off dust from the power plug using a dry cloth.
- **If the power cord is damaged, it must be replaced by the manufacturer, its service agent, or similarly qualified personnel to avoid hazards.**
- **For continued safety of this appliance it must be installed, operated and maintained in accordance with the manufacturer's instructions.**



## CAUTION

### For construction



Must do

- **The water supplied to the system must meet drinking water quality standards or relevant national water quality regulations.**  
(Using hot spring water, well water, or any water not meeting these standards may result in malfunctions or water leakage.)
- **If the water heater will not be used for an extended period after installation, drain the water from both the tank unit and CO<sub>2</sub> heat pump unit after a test run. Ensure that no water remains inside the units until the system is used again.**  
(If water is left inside for a long time, changes in water quality may pose health risks or cause equipment malfunction.)
- **The floor surface where the tank unit is installed must be waterproofed and capable of draining water properly in the event of leakage.**

(If not, water may enter the surrounding building and cause damage to property.)

- **Do not touch the air outlet or aluminum fins of the CO<sub>2</sub> heat pump unit.**  
(This may cause injury.)
- **Do not install the water heater in locations where small animals may inhabit the surrounding area or enter the unit.**

(If small animals enter the device and touch electrical components, it may result in smoke or fire.)

- **Be sure to follow the installation manual when performing drainage work.**  
(Failure to do so may result in water intrusion into surrounding structures, leading to property damage.)

- **Install indirect drainage for the relief valve outlet piping without fail.**  
(If not properly drained, tank damage may cause water leakage, and if contaminated water backflows into the tank, changes in water quality may pose health risks.)

- **When connecting drain piping to the sewer system, ensure that sewer gas does not backflow by installing a drain trap.**

(If sewer gas flows back into the system, it may corrode the piping and cause water leakage.)

- **Ensure the system and piping are installed in a way that prevents freezing.**  
(Freezing and damage to the pipes may result in burns or water leakage.)



Don't do



Must do

### For construction



Must do

- **When securing screws to a wall, ensure the screws are electrically insulated from any metallic mesh within the wall.**  
(If not insulated, heat may build up at the contact point between the screw and the mesh, posing a risk of fire.)
- **For electrical work, follow the wiring rules AS/NZS 3000, national regulation, legislation and this installation instructions. An independent circuit and single outlet must be used. If electrical circuit capacity is not enough or defect found in the electrical work, it will cause electrical shock or fire.**
- **It may need two or more people to carry out the installation work.**
- **It is not permitted to describe that the equipment, CO<sub>2</sub> Heat Pump Hot Water System is secured only by adhesives.**



Don't do

### For repair of the product



Must do

- **To prevent electric shock, turn off the power and unplug the unit:**
  - The appliance must be disconnected from its power source during service and when replacing parts.

# Using a natural refrigerant of CO<sub>2</sub> makes hot water with high efficiency from atmospheric heat, realizing earth-conscious hot-water supply.

Energy-saving effect gained through the use of the CO<sub>2</sub> heat pump hot water system is visualized on a dedicated app.

Smartphone operation makes it possible to make comfortable hot water with peace of mind when needed.

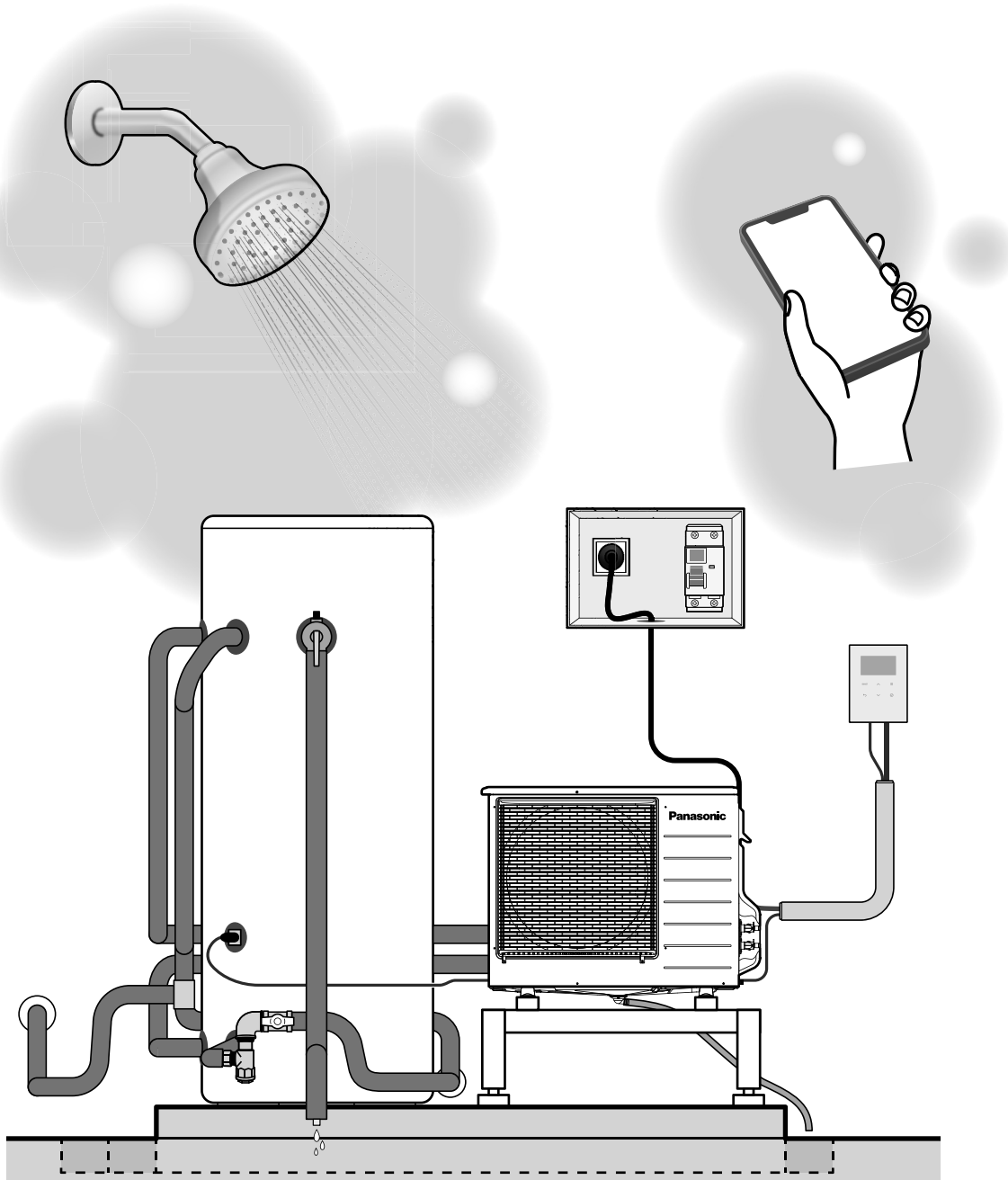

# Owner's operation manual

## Contents

	Page
<b>Important (Precautions to Users of the Hot Water System)</b>	<b>10</b>
Check the following before using the system.	10
Hot water shortage may occur.	10
In cold weather	10
A sink or other areas around the water mixing tap become blue.	11
Space for periodical inspection and maintenance (repair work) is required.	11
<b>Part Names and Functions</b>	<b>12</b>
Controller	12
CO <sub>2</sub> heat pump unit	14
Tank unit	14
<b>First Time Use</b>	<b>15</b>
Filling up the tank	15
Turning on the power	16
Initialising the hot water system	16
Date and time setting	17
First filling the tank with hot water	17
<b>How to Heat Water</b>	<b>18</b>
Overview of water heating process	18
Example of using hot water a day	18
Configuring heating settings in operation mode	19
Forcibly re-heating when hot water shortage is likely to occur: [BOOST]	19
Heating a generous volume of water economically [24H]	20
Heating water in the preset time zone [10PM to 7AM] [12AM to 6AM] [10AM to 4PM]	21
Heating water twice a day [Timer/Temperature]	22
<b>Other Settings</b>	<b>24</b>
Locking controller operation [Control lock]	24
Changing the heating start temperature [Tank heat-up start temp]	25
<b>Convenient Options</b>	<b>26</b>
Linking up with photovoltaic (solar) power generation [PV timer]	26
<b>Maintenance</b>	<b>27</b>
Checking the controller display	27
Inspecting the earth leakage breaker	27
Cleaning the tank	28
Inspecting the tank unit relief valve	29
Recommendation for regular inspections	29
Inspection and maintenance details	29
Replacement of consumable parts	29
<b>When Not Using for Long periods</b>	<b>30</b>
When not using hot water for 1 to 30 days [Holiday]	30
When not using hot water one month or longer, or turning off the power	31
<b>When power failure has occurred</b>	<b>32</b>
When power failure continues for 15 days or more	32
When power failure is restored	32
About heating to prevent the growth of legionella bacteria when power failure is restored	32
<b>When water outage has occurred</b>	<b>33</b>
When water outage is restored	33
Air-purging the piping using the controller	33
<b>Troubleshooting</b>	<b>34</b>
Symptom & cause	34
Q & A	36
When the controller indicates an error	37

# Important (Precautions to Users of the Hot Water System)

---

## Check the following before using the system.

---

- **The CO<sub>2</sub> heat pump unit makes operation sounds while water is being heated.**  
Make sure that the unit is installed at a location where the neighbors are not disturbed.
- **After the tank is filled up and purged, water must be heated.**  
Make sure that the dealer (construction operator) where the product has been purchased has already done this work. If not, make preparations according to "First Time Use" (P.15).
- **This appliance is permanently connected to water mains. Note that water leakage from the hot water system may cause spread of damage.**

## Hot water shortage may occur.

---

- **Using a large amount of hot water may exhaust the hot water.**
  - To prevent shortage of hot water Diligently stop shower.
  - When a large amount of hot water is used, or water shortage is likely to occur, operate [BOOST] to heat water beforehand.
  - Select a heating setting (operation mode) according to the usage of hot water.

## In cold weather

---

- **When it is forecast to be below freezing, take measures beforehand to prevent the (hot) water supply pipe from freezing.**

---

A sink or other areas around the water mixing tap become blue.

- Depending on the water quality in your area and the copper piping of the water heater, a sink or other areas around the water mixing tap become blue. This is caused by a reaction between trace amounts of copper ions dissolved in the water and fatty acids contained in soap. There is no harm to the human body.

Space for periodical inspection and maintenance (repair work) is required.

- Do not additionally construct walls, etc. near the location where the tank unit or CO<sub>2</sub> heat pump unit is installed. Doing so will hamper maintenance work such as periodical inspections, repair work, and removal of the units.

# Part Names and Functions

## Controller

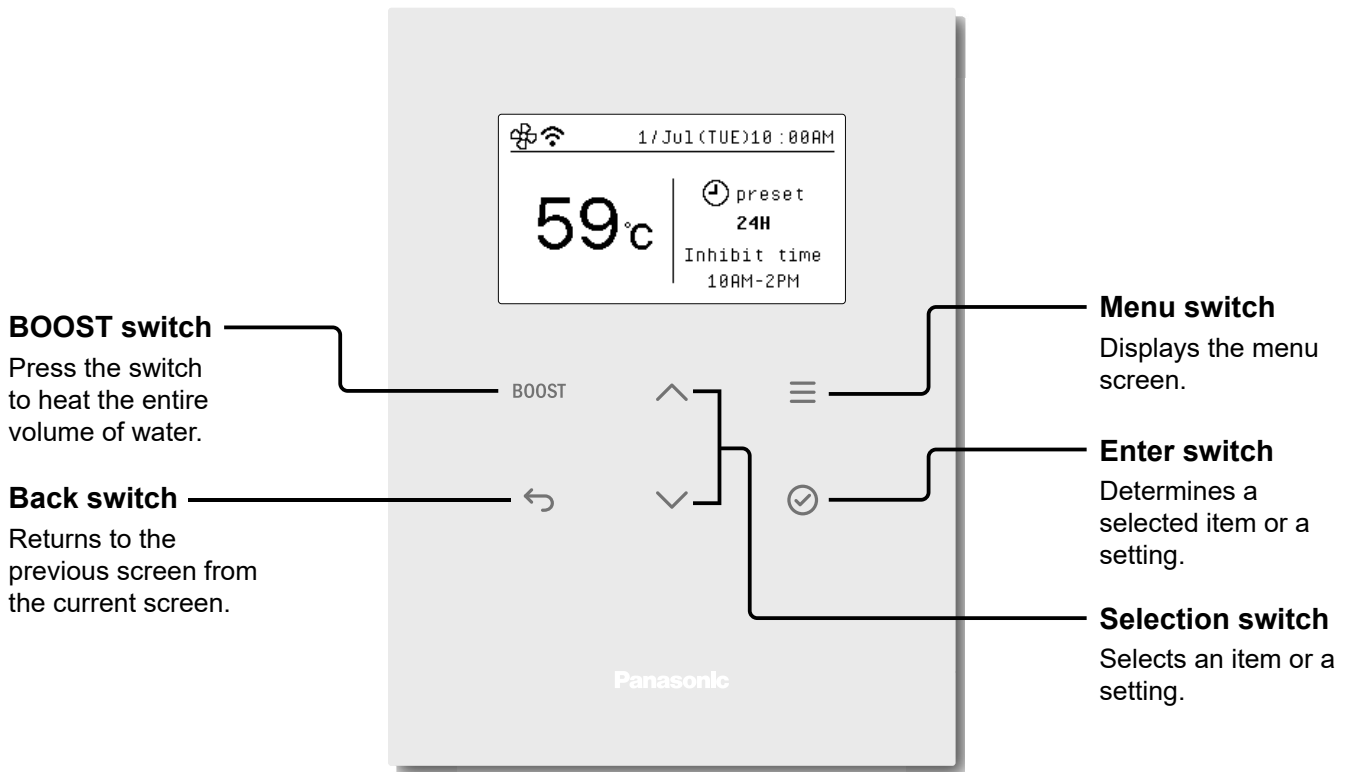

### Screen display

The backlight of the display remains on for 10 seconds after a button is pressed.

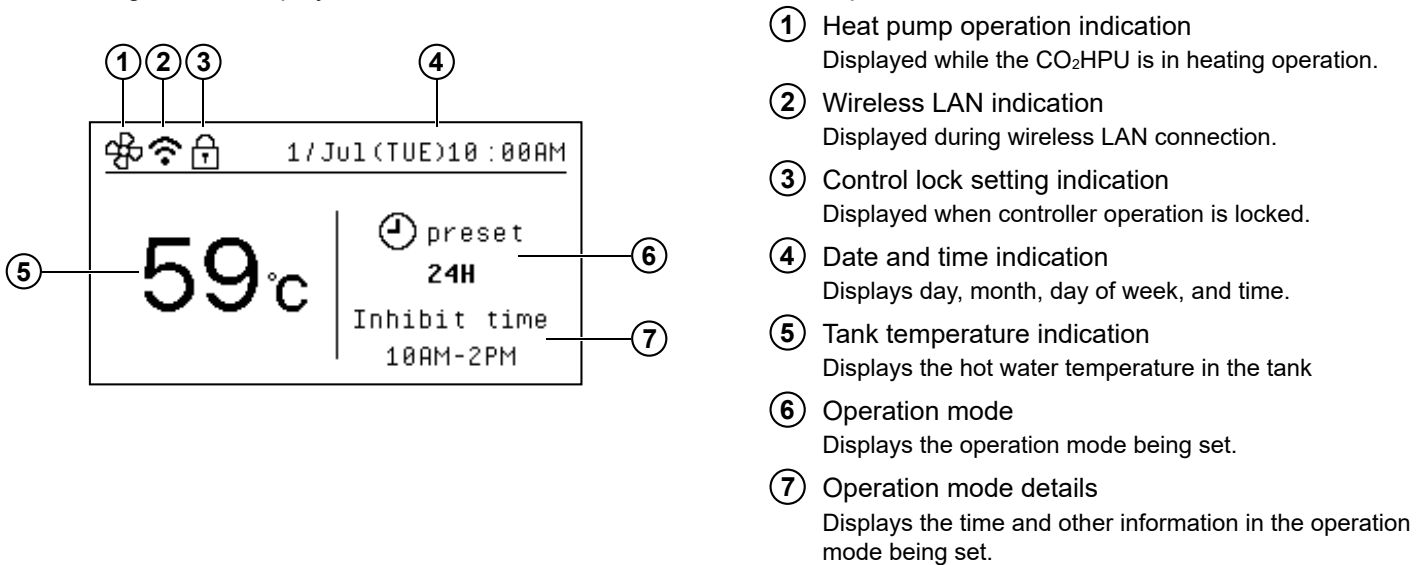

## Menu screen

Pressing the menu switch switches to the menu screen, and allows for the setting of items shown in the table below.

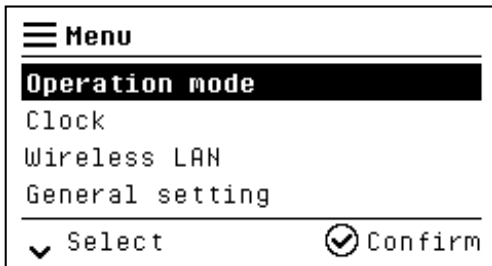

Menu	Layer1	Layer2	Use	Page	
Operation mode	24H	Inhibit time	When a generous volume of water is heated economically	P.20	
	10PM to 7AM		When heating water only in the predetermined time zone with a simple setting	P.21	
	12AM to 6AM				
	10AM to 4PM				
	Timer/Temperature	Set-1	Set-2	When hot water to be used in a day is prepared twice	P.22, P.23
		Set-2			
	PV timer		When photovoltaic (solar) power generation is used for heating	P.26	
Holiday		When heating is suspended with the power of the hot water system remaining ON.	P.30		
Clock			When the clock of the controller is adjusted for daylight-saving time, etc.	P.17	
Wireless LAN*	Wireless LAN ON/OFF		When the hot water system is connected to the network communication When a dedicated app is used	P.69 -80	
	Network setting				
	Signal strength				
	Initialization				
General setting	Contrast setting		When the controller screen is adjusted according to the surrounding brightness	P.27	
	Air purge		When water cannot be heated normally after recovery from water outage	P.33	
	Tank heat-up start temp		When re-heating timing is adjusted according to the usage volume of hot water	P.25	
	Control lock		When controller operation is locked to prevent tampering conduct or incorrect operation	P.24	
	Reset to default data ("Reset to default data" is displayed by pressing and holding the  switch for four seconds.)			When the hot water system is discarded, transferred, or received from a third party, and the information of the user is deleted	P.16
Failure history			When an error display on the controller screen is checked	P.37	

\*: This function is used with the dedicated app. For details, refer to the description of the dedicated app.

# Part Names and Functions (Continued)

## CO<sub>2</sub> heat pump unit

(Hereafter referred to as CO<sub>2</sub>HPU)

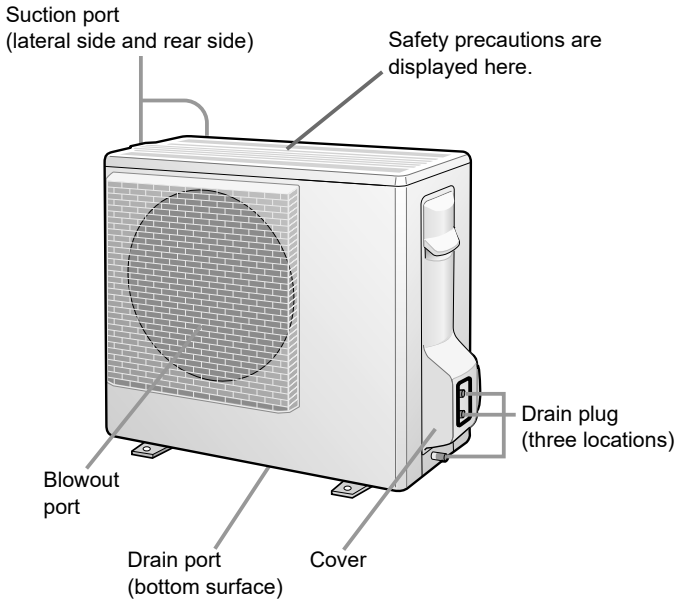

### Drain elbow

The drain elbow is connected to the drain port and used to discharge drain water.

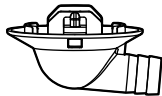

## Tank unit

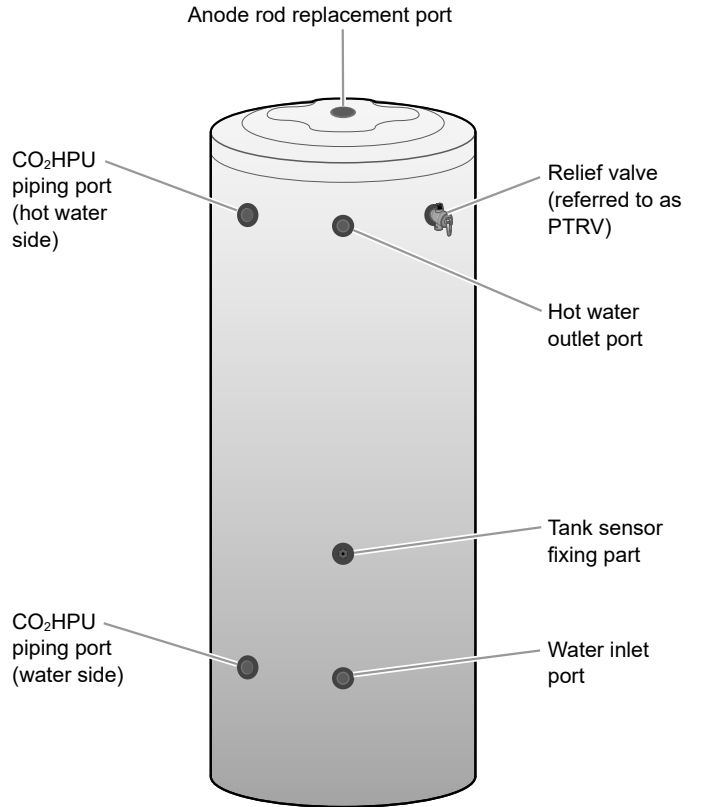

# First Time Use

## Filling up the tank

**Fill up the tank, and make sure no water leakage is found.**

- Operate the piping members according to the following steps.

**1** Operate the relief valve (PTRV) lever to open it.

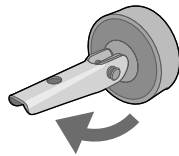

**2** Open the water supply main tap\*.

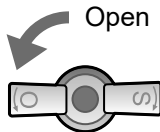

**3** Confirm that water comes out from the PTRV outlet port.

- The tank is full of water if the water begins to come out successively. Up to approx. 40 minutes are taken.

**4** Lower the PTRV lever to close it.

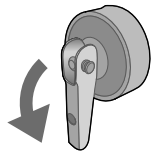

**5** Open the tap on the hot water side of the household water mixing tap. When water containing air stops coming out and water begins to come out successively, close the water mixing tap.

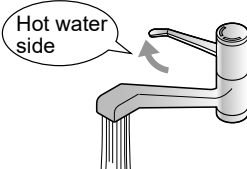

\*: If the water supply main tap is not mounted at the position in the figure, check with the dealer where the product has been purchased. (Depending on the plumbing work, the mounting position may differ.)

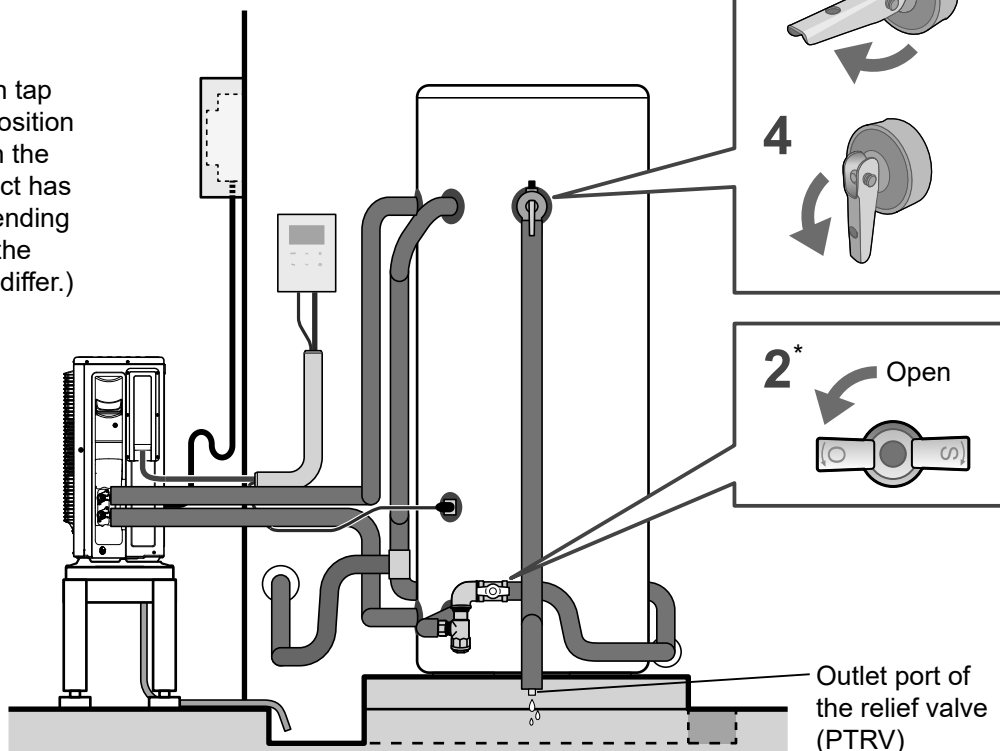

**Discharge the air from the CO<sub>2</sub> heat pump unit.**

- Make sure that the following step has been completed. If the step is not completed correctly, the heat pump unit may malfunction.

**6** Open the three drain plugs. (Do not remove the drain plugs not to lose them.) Run water for at least one minute. Make sure that water containing air stops coming out and water begins to come out successively. Then close all drain plugs.

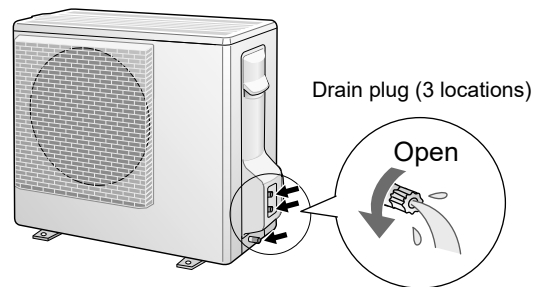

# First Time Use (Continued)

## Turning on the power

Make sure that the tank is filled up, and then turn on the power. (A malfunction may occur.)

- 1 Insert the power cord plug of the CO<sub>2</sub>HPU to the prescribed socket.
- 2 Turn [ON] the earth leakage breaker.

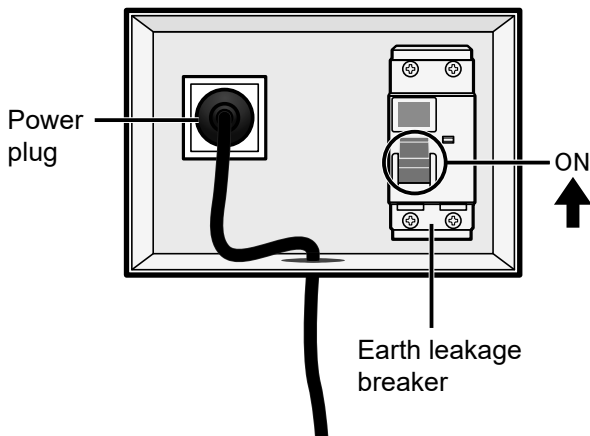

### WARNING



- To prevent overheating, fire or electric shock, observe the following:

- Do not share the power outlet with other devices
- Do not operate with wet hands
- Do not excessively bend the power cord
- Do not turn the CO<sub>2</sub> Heat Pump unit on or off by plugging or unplugging the power cord



- Insert the plug correctly.
- Wipe off dust on the plug with a dried cloth periodically.

## Initialising the hot water system

If the hot water system has already been installed, wireless LAN connection information and other information of a person who previously used the system may remain. So be sure to initialise the system.

### NOTE:

- When a new CO<sub>2</sub> heat pump hot water system is purchased and installed, there is no need to initialise the system settings.

- 1 Press Menu .  
Select [General setting] with , and press Enter

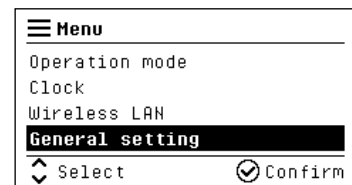

- 2 Place the cursor over [Control lock] with , and press and hold for four seconds.

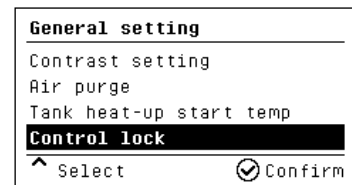

- After four seconds have passed, is displayed on the bottom left of the screen.

- 3 Move down the cursor, select [Reset to default data], and press Enter .

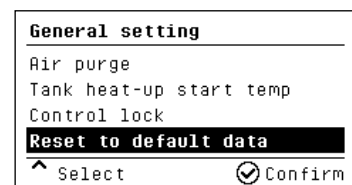

- 4 Select [YES] with , and press Enter .

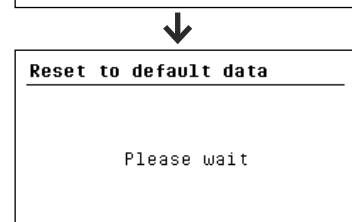
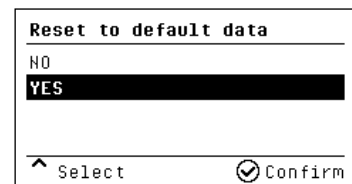

- After the above screen is displayed, return to the main screen. Then initialisation is complete.

## Date and time setting

- Regarding Daylight Saving Time Adjustment
  - Whether daylight saving time is observed, not observed, or when the change occurs varies depending on the city.
  - The date and time setting on the controller does not switch automatically. Please adjust it manually to the correct time.

- Press Menu . Select [Clock] with , and press Enter .

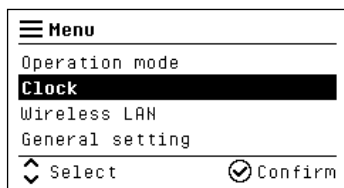

- Select [Year] with  , and press Enter  to proceed. Next, select [Month] and [Day] in the same way.

- Selecting Back  returns to the previous item.

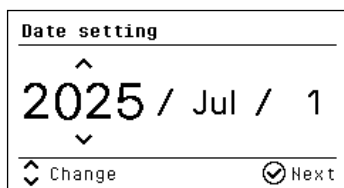

- Select [Hour] with  , and press Enter .

- 12 o'clock midnight is [12:00 AM].
- Continuously pressing   fast-forwards the time.

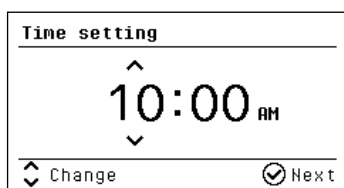

- Select [Minute] with  , and press Enter .

- Continuously pressing   fast-forwards the time.

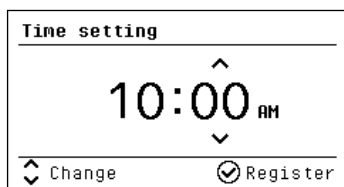

- If power outage continues for a long period of time, the date and time may be reset. Before using the system, make sure that the time display is correct. Note that an unexpected electric fee may be charged.

## First filling the tank with hot water

- Since the CO<sub>2</sub> heat pump water heater cannot supply hot water unless hot water is pre-stored in the tank, it is necessary to start the heating operation in advance.
- When "Initialising the hot water system" on the previous page has been performed, set the date and time for [Clock], and then perform the following operation.
- While filling the tank with hot water, carefully read "How to Heat Water" on the next page, and select an operation mode the most suitable for your home situation.

### NOTE:

- When the settings of the hot water system have not been initialised, heating starts automatically after date and time is set. So this operation is not required.

- With the main screen displayed, press and hold [BOOST] for five seconds.

- On a screen on which another operation is performed using the controller, [BOOST] is not displayed.

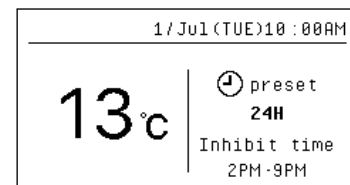

-  is displayed on the controller during water heating operation, and preparatory operation is in progress. During [BOOST], the water is heated to 63 °C, and heating stops when the temperature displayed on the controller reaches 59 °C.
- When "H94 error" is displayed on the controller... When water outage continues for one day or more and air accumulates inside the piping of the CO<sub>2</sub>HPU, water may not flow normally, resulting in heating suspension. Turn [OFF] the earth leakage breaker, and turn off the power for approx. one minute. Then the error display disappears. Next, perform operations as in "Performing air-purge the piping using the controller (P.33)" and "Discharge the air from the CO<sub>2</sub> heat pump unit (P.15)".

# How to Heat Water

## Overview of water heating process

- The CO<sub>2</sub>HPU makes hot water efficiently using atmospheric heat.
- When the water in the lower part of the tank is heated, the built-in water pump has a function to store the hot water in the upper part of the tank while adjusting the flow rate so that the temperature is maintained constant at 63 °C.
- The hot water in the upper part of the tank barely mix with the tap water in the lower part since there is a large temperature difference. Therefore, stably high temperature water can be used very comfortably even while heating is in progress.
- When the temperature detected by the tank sensor reaches 59 °C (controller indication), the heating operation is completed.

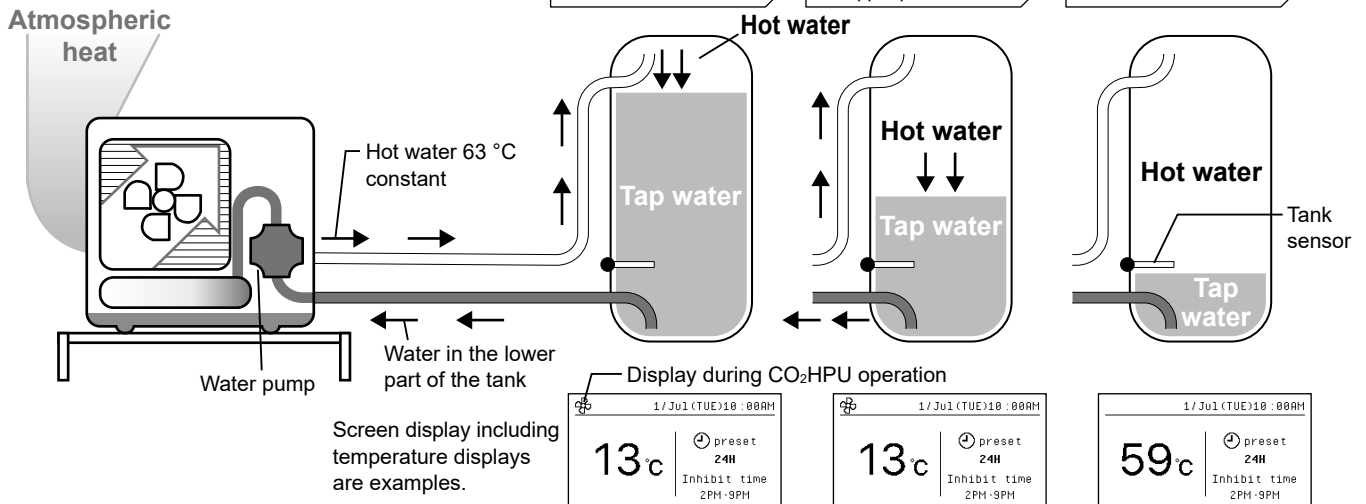

## Example of using hot water a day

- Storing sufficient hot water in the tank is required to use hot water.
  - Here is an example of the time required to fully heat a 315 L tank. Please use this as a reference for setting the heating time range. The values may vary depending on installation and usage conditions. (For fully heating water from 8 °C to 63 °C)

### ■ Estimated Time Required for Full Heating

CO <sub>2</sub> HPU	Tank unit : HE-TM315AHR	Outdoor temperature
HE-UM60CR	300 min (5.0 hours)	1.2 °C

The required time may vary depending on the CO<sub>2</sub>HPU and tank unit, so please use this as a guideline.

- An example is shown at right.
  - When the water mixing tap is opened in a washroom, kitchen, bathroom, etc., hot water in the upper part of the tank comes out, and the temperature-adjusted hot water can be used. At the same time, the volume of tap water equivalent to the volume that has been used is replenished gradually from the bottom of the tank.
  - The tap water is replenished up to the position of the tank sensor. When the controller indicates 37 °C, re-heating starts automatically. (only in time zone for heating)
  - When more hot water is used, there will be no hot water remaining in the tank. The hot water is exhausted even during heating.
  - Even if the hot water is not used, the temperature of the entire tank may be lowered over time, and the temperature display on the controller may be lowered.

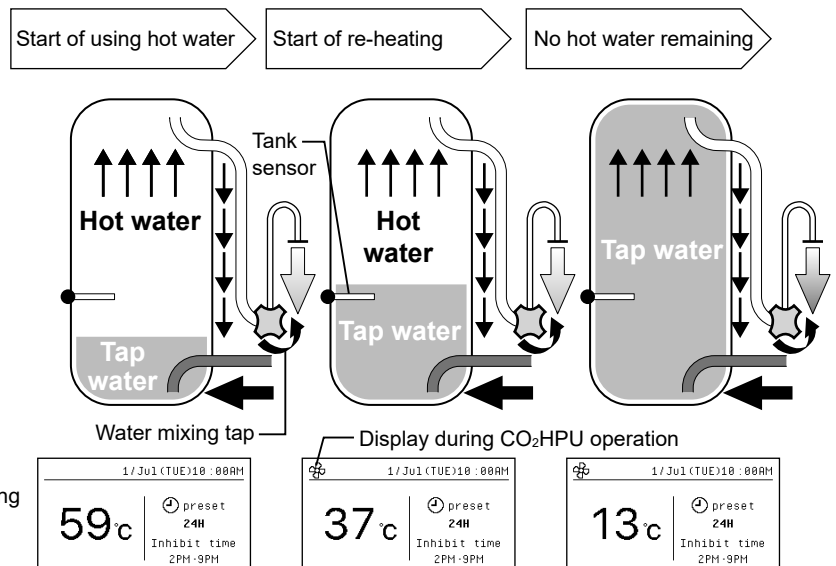

# Configuring heating settings in operation mode

Select the most suitable mode according to the daily usage of hot water.

Operation mode	Setting guideline	Heating method	Page
<b>24H</b>	When heating a generous volume of water economically	Time zones in which the system is not operated can be set to avoid heating to suppress electricity peak caused by domestic duties, use of the air conditioner, or relatively high electricity rate.	P.20
<b>10PM to 7AM</b>	When heating water only in the predetermined time zone with a simple setting	The entire volume in the tank is heated for nine hours from 10 p.m. at night.	P.21
<b>12AM to 6AM</b>		The entire volume in the tank is heated for six hours from 12 a.m. at night.	
<b>10AM to 4PM</b>		The entire volume in the tank is heated for six hours from 10 a.m. in the morning.	
<b>Timer/ Temperature</b>	When hot water to be used in a day is prepared twice	Two types of settings of Set-1 and Set-2 are available. <ul style="list-style-type: none"> <li>• Set-1: In the first heating, the entire volume in the tank is heated for three hours or more.</li> <li>• Set-2: In the second heating, water is heated by selecting temperatures to start and end heating, and a time zone for heating, and by restricting the volume of hot water.</li> </ul>	P.22 P.23
<b>PV timer</b>	When a photovoltaic (solar) power generation system is installed	The photovoltaic (solar) power generation is used for re-heating. (Optional construction is required to use solar power generation.)	P.26
<b>Holiday</b>	When hot water is not used for a certain period of time due to travel, etc. (guideline: 1 to 30 days)	Heating is stopped with the power of the hot water system remaining ON. Required maintenance becomes simple.	P.30

## Forcibly re-heating when hot water shortage is likely to occur: [BOOST]

Using a larger amount of hot water than usual may exhaust the hot water when needed.

Using a small amount of hot water reduces the number of times for automatic reheating, which may lower the temperature of the entire tank, causing inconvenience of using hot water.

In any case, it is recommended to press "BOOST" to manually reheat the water.

**1** Press [BOOST].

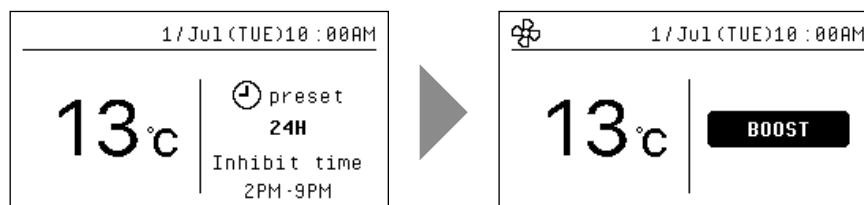

- The [BOOST] function works only on the main screen.
-  is displayed on the controller during water heating operation, and preparatory operation is in progress. During [BOOST], the water is heated to 63 °C, and heating stops when the temperature displayed on the controller reaches 59 °C.

• Pressing [BOOST] again interrupts heating.

### NOTE:

- The CO<sub>2</sub>HPU always monitors the outside temperature so as not to cause inconvenience due to freezing, and may automatically start operation for reheating. This is not a malfunction.

# How to Heat Water (Continued)

## Heating a generous volume of water economically [24H]

To perform economical operation, heating is suppressed in time zones in which the electricity rate becomes high or power consumption intensively increases due to domestic duties or the use of the air conditioner.

The following is an example when heating is stopped from 2 p.m. to 9 p.m.

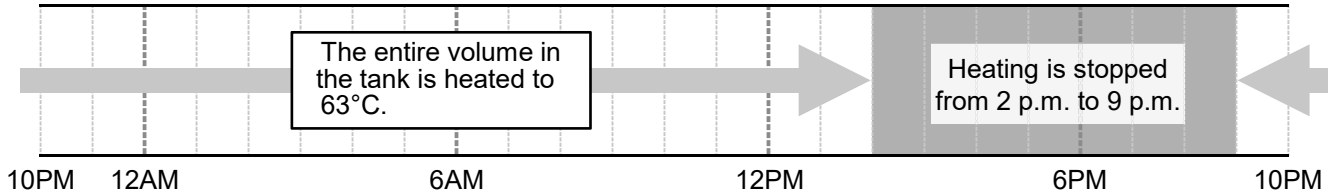

- 1 Press Menu .  
Select [Operation mode] and press Enter .

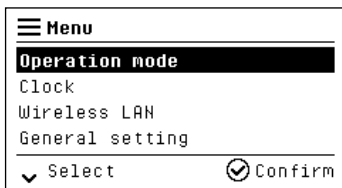

- 2 Select [24H] and press Enter .

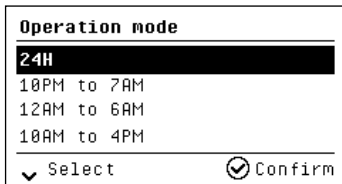

- 3 Select [Inhibit time:] and press Enter .



- 4 Select [On] with , and press Enter .

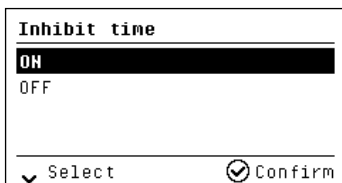

- 5 With , select a start time and end time of the time zone in which heating is stopped, and press Enter .

- Continuously pressing fast-forwards the time.
- Selecting Back returns to the previous item.

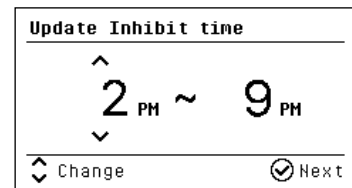

- 6 Select [OK] with , and press Enter .

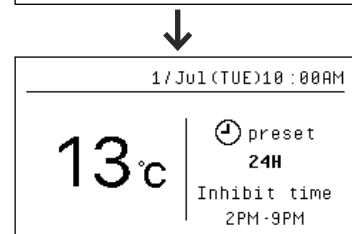
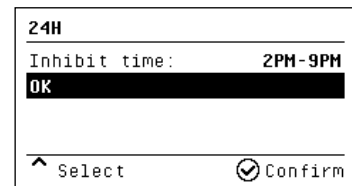

- After the setting is complete, confirm again that the current time and the setting contents are correct. If the setting is wrong, an unexpected electric fee may be charged.

# Heating water in the preset time zone

## [10PM to 7AM] [12AM to 6AM] [10AM to 4PM]

Heating is performed in any of the three patterns of time zones that have been preset.

In each preset time zone, the entire volume in the tank is heated to 63 °C. (see below)

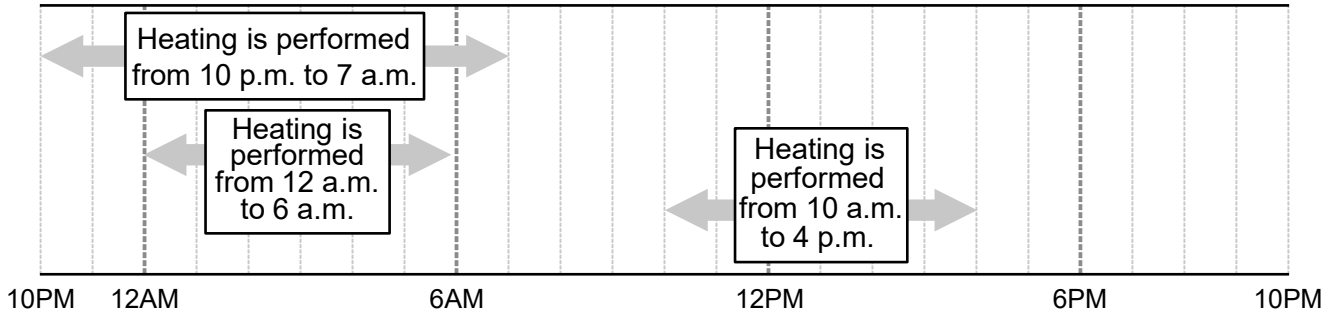

- 1 Press Menu . Select [Operation mode] and press Enter .

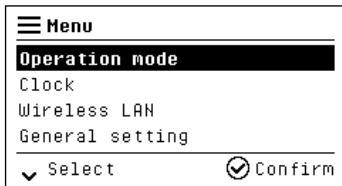

- 2 Select a time zone for heating with , and press Enter .

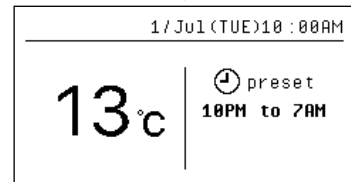
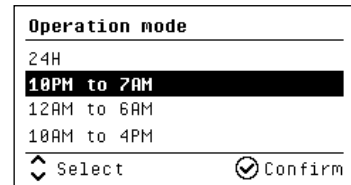

- After the setting is complete, confirm again that the current time and the setting contents are correct. If the setting is wrong, an unexpected electric fee may be charged.

# How to Heat Water (Continued)

## Heating water twice a day [Timer/Temperature]

Hot water to be used in a day is prepared twice.

This setting is suitable for using a small amount of hot water at a certain time in the night, such as when taking a shower or bath at midnight.

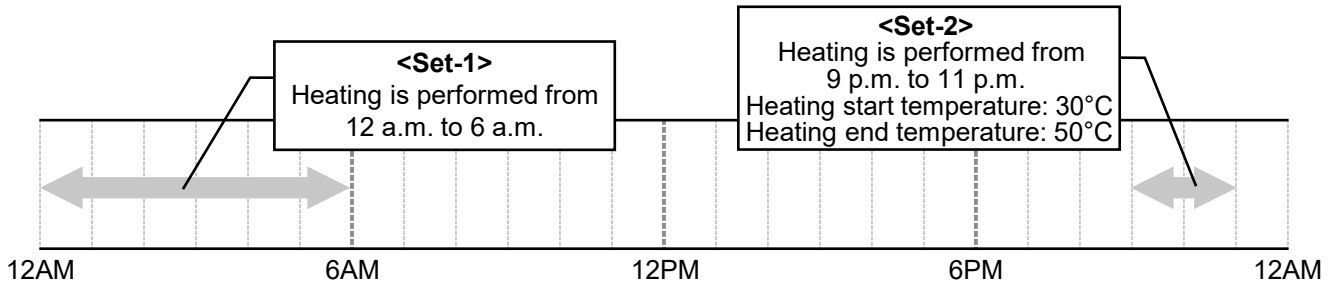

- 1 Press Menu .  
Select [Operation mode] and press Enter .

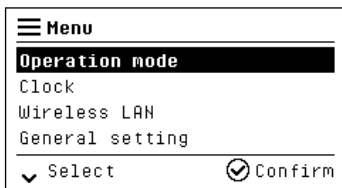

- 2 Select [Timer/Temperature] with , and press Enter .

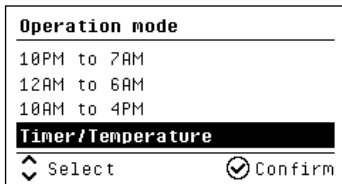

- 3 Select [Set-1] and press Enter .

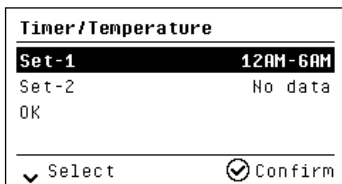

- 4 Select a start time and end time for heating, and press Enter .

- Set a time zone with at least three hours.
- Continuously pressing fast-forwards the time.
- Selecting Back returns to the previous item.

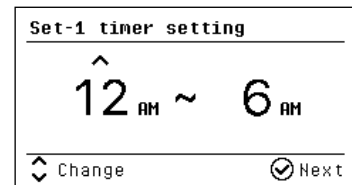

- 5 Select [Set-2] and press Enter .

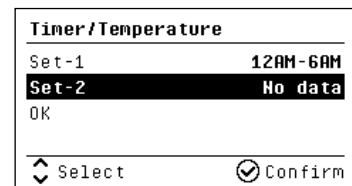



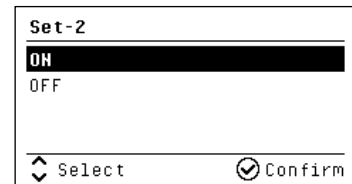

- Set [Set-2] with at least one hour.
- When the end time of [Set-1] is set to [12AM], [Set-2] cannot be set. [Not available] is displayed on the screen. Change the end time of [Set-1].





- 6 Select [OK] with , and press Enter .

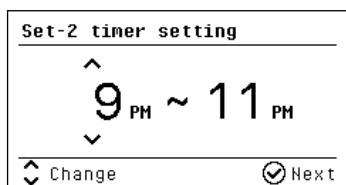

- When Set-2 is not set, select [OFF].  
Select [OK] on the next screen, and press Enter .
- Then, the setting is complete.

- 7** Select a start time and end time for heating, and press Enter .
- Set an arbitrary time zone between the end time of Set-1 and 12 a.m.
  - Continuously pressing   fast-forwards the time.
  - Selecting Back  returns to the previous item.



- 8** Select a start time and end time for heating, and press Enter .
- To make a small amount of water, set a heating start temperature (30 °C to 49 °C) and end temperature (50 °C to 59 °C).
  - Continuously pressing   fast-forwards the time.
  - Selecting Back  returns to the previous item.

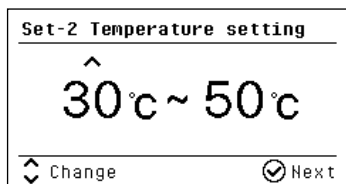

- 9** Select [OK] with , and press Enter .

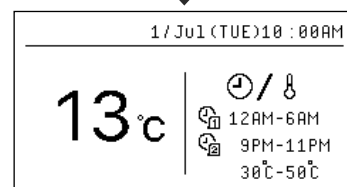
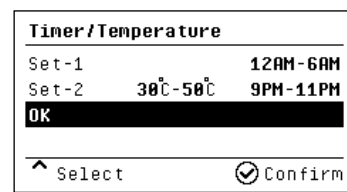





- After the setting is complete, confirm again that the current time and the setting contents are correct. If the setting is wrong, an unexpected electric fee may be charged.

# Other Settings



## Locking controller operation [Control lock]

The controller operation can be locked to prevent tampering conduct or incorrect operation on the controller.

### Locking

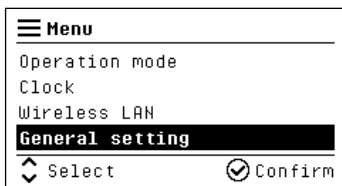
- 1 Press Menu   
Select [General setting] with  , and press Enter .



- 2 Select [Control lock] with  , and press Enter .

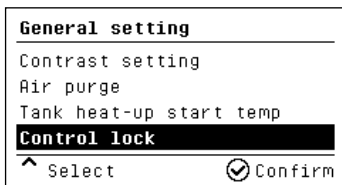

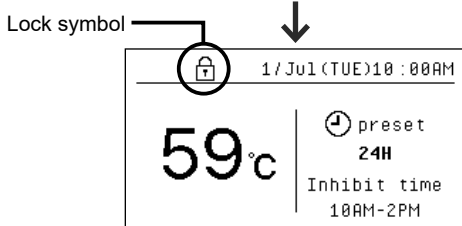
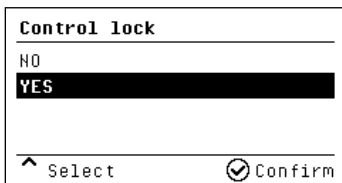

- 3 Select [YES] with  , and press Enter .



- The lock symbol lights up on the upper left of the screen.

### Releasing lock

- 1 With the main screen displayed, press and hold  , and press Enter  for four seconds.

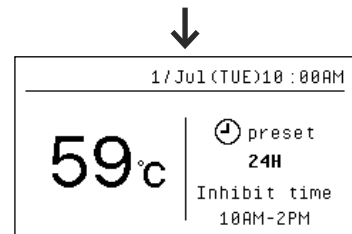
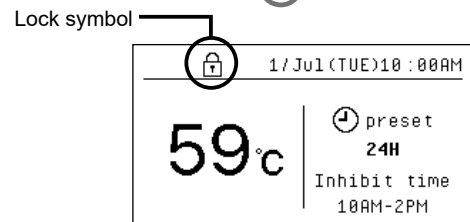

- The lock symbol disappears, and the lock is released.

### NOTE:

- Operation is possible from the dedicated app even during control lock.
- The lock is not released even if a power failure continues for a long period of time, or if the power is turned on again after the power plug is disconnected.

# Changing the heating start temperature [Tank heat-up start temp]

Re-heating timing is adjusted according to the usage volume of hot water at home.

- When reducing the number of times for re-heating, set the heating start temperature to lower degrees. An example is shown at right. It is economical since re-heating is performed after the hot water is used up.

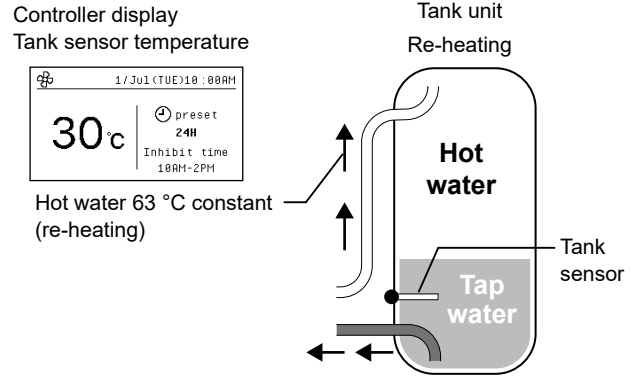

- When increasing the number of times for re-heating, set the heating start temperature to higher degrees. An example is shown at right. Not much hot water is used at home, the period re-heating is not performed becomes longer, the temperature of the entire tank becomes lower, and the hot water temperature may not be stabilized. Increasing the number of times for re-heating allows the upper part of the tank to be kept at high temperatures. As a result, the temperature of the hot water to be used will be stabilized.

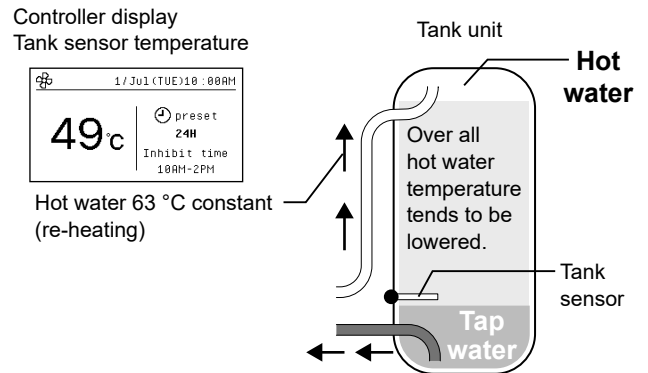

The controller display and the tank unit illustration are examples.

- Press Menu . Select [General setting] with , and press Enter .

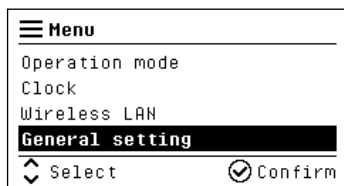

- Select [Tank heat-up start temp] with , and press Enter .

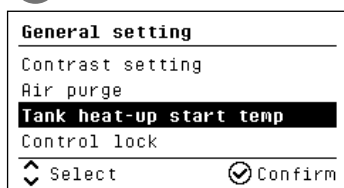

- Select a temperature to start heating with , and press Enter .

- The temperature can be set between 30 °C and 49 °C.
- Continuously pressing fast-forwards the time.

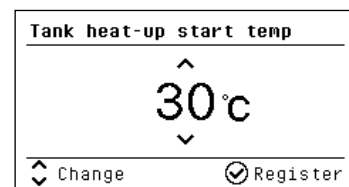

# Convenient Options

## Linking up with photovoltaic (solar) power generation [PV timer]

When a photovoltaic (solar) power generation system is installed at home, water can be heated by utilizing electricity of solar power generation.

When using the photovoltaic power generation, a construction to connect a PV-DRY cable to the controller is required. For details, ask the dealer where the product has been purchased.

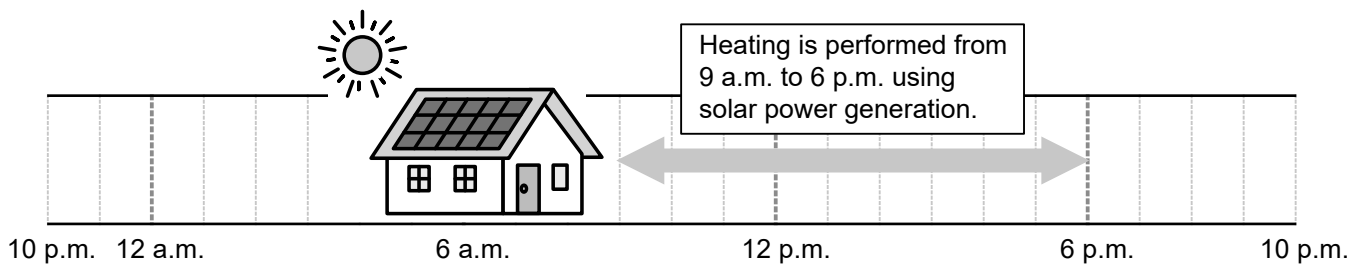

- 1 Press Menu .  
Select [Operation mode] and press Enter .

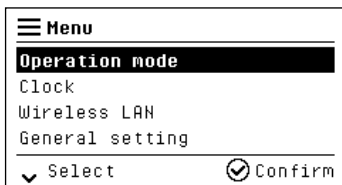

- 2 Select [PV timer] with , and press Enter .

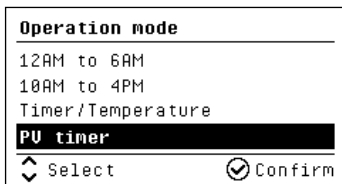

- 3 Select a start time and end time of the time zone to link up with the solar power generation with , and press Enter .

- Continuously pressing fast-forwards the time.
- Selecting Back returns to the previous item.

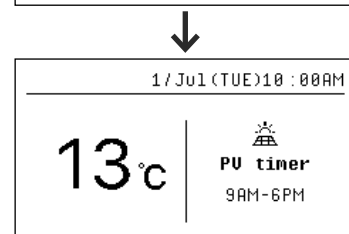
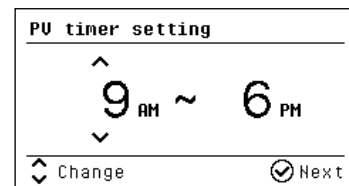

### NOTE:

- If the amount of solar radiation is insufficient depending on the weather condition, heating may not be performed with the electricity of the solar power generation. In that case, it is recommended to heat the entire volume in the tank by pressing [BOOST] earlier.

# Maintenance





## Checking the controller display

Wipe the surface with a dry cloth or wet cloth.

- The display and case surfaces can be easily scratched. If sand or other particles are present, rubbing them directly may cause scratches. Be sure to remove any debris first, then gently wipe the surface with a soft cloth.
- Do not use organic solvents such as benzene and thinner. (Doing so may cause deformation or discoloration.)
- When the display is difficult to view due to the effect of the surrounding brightness, it is recommended to adjust the contrast of LCD.

### Adjusting the contrast of LCD

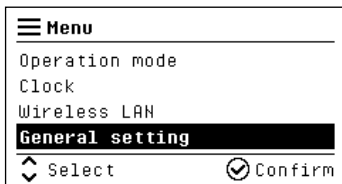

The contrast can be adjusted manually for easy viewing according to the surrounding brightness and temperature.

- 1 Press Menu .  
Select [General setting] with  , and press Enter .

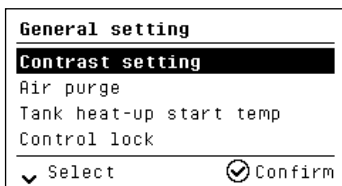

- 2 Press Enter  when [Contrast setting] is displayed.



- 3 Select a contrast level with  , and press Enter .

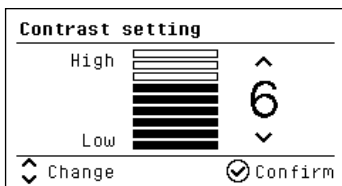

- Since the contrast level is reflected on the operation screen, select an optimal level.

## Inspecting the earth leakage breaker

Perform periodical inspections according to the user manual of the earth leakage breaker.

- Note that when an electrical leakage failure has occurred in the hot water system, the earth leakage breaker may not operate normally.

### NOTE:

- If a failure is found through the inspection, an electrical leakage may have occurred. Contact the dealer where the product has been purchased.

# Maintenance (Continued)

## Cleaning the tank

Cleaning the tank is recommended when the hot water system is used for the first time. After use, it is recommended to clean the tank two or three times a year.

### Drain the tank to flush out any sediment from the bottom.

Do not clean the tank when the controller indicates 50 °C or more. Hot water will come out, and may cause a burn injury.

- 1 Turn [OFF] the earth leakage breaker.
- 2 Remove the power plug from the socket.
- 3 Close the water supply main tap
- 4 Raise the relief valve lever.
  - A certain volume of water comes out from the outlet port of the relief valve. Leave it until no water comes out.
- 5 Remove the strainer.
  - When the water in the tank began to be drained, rinse with flowing water for approx. two minutes.

**WARNING**



- Do not touch the hot water.

- 6 Lower the relief valve lever, and wait until water stops.
- 7 Wash the strainer (filter) with water, and attach it.
- 8 Raise the relief valve lever, and open the water supply main tap to fill up the tank.
- 9 When hot water containing air stops coming out from the outlet port of the relief valve, lower the relief valve lever.
- 10 Insert the power plug to the socket, and turn [ON] the earth leakage breaker.

#### NOTE:

- If a failure or water leak is found during maintenance, contact the dealer where the hot water system has been purchased.

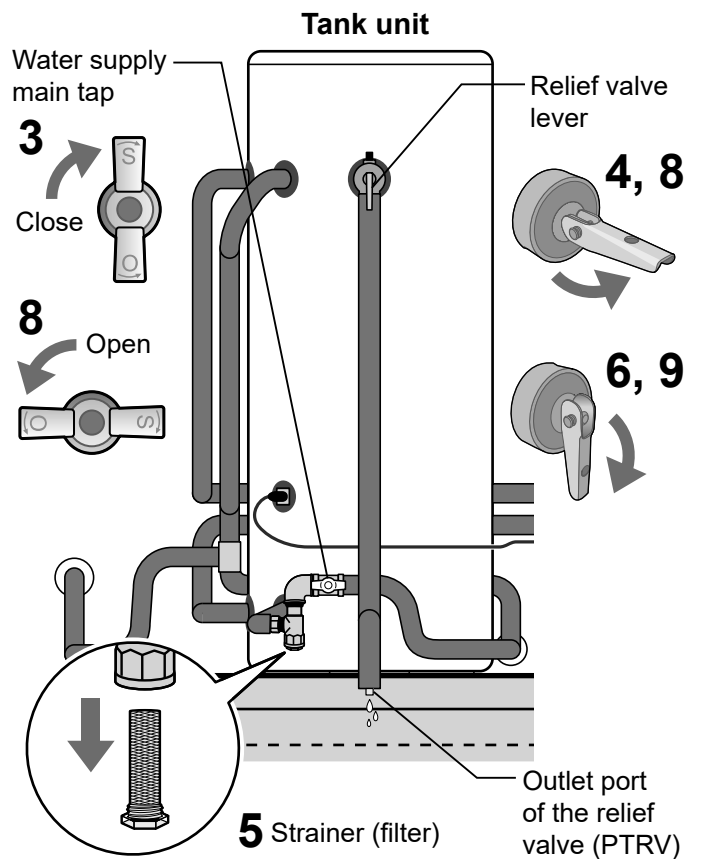
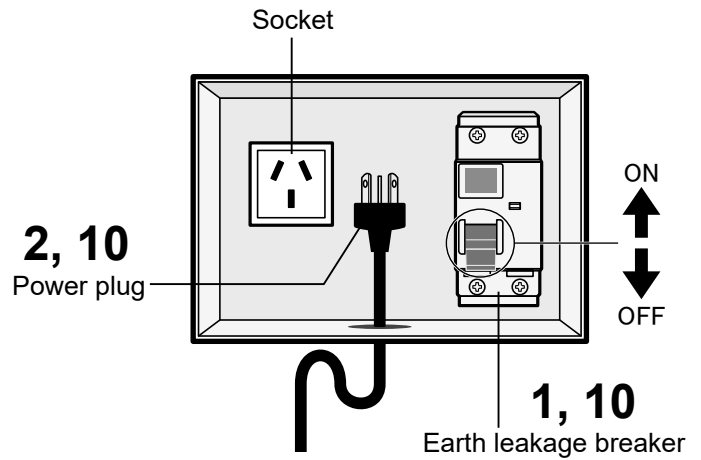

- 7 Wash the filter with water.



## Inspecting the tank unit relief valve

It is recommended to inspect the relief valve two to three times a year.

### Relief valve operation inspection

- 1 Raise the relief valve lever.
- 2 Confirm that hot water comes out from the outlet port of the relief valve. (approx. 10 seconds)
- 3 Lower the relief valve lever, and confirm that hot water stops.

#### NOTE:

- While the water is being heated, hot water or water comes out from the outlet port of the relief valve and drainage pipe outlet. So always open those outlet ports to the atmosphere without blocking them.

### Water leak inspection

Do not perform inspection when  is displayed on the controller screen.

Water leak inspection is not available since the hot water comes out from the outlet port of the relief valve while the heating operation.

- 1 Confirm that hot water does not come out from the outlet port of the relief valve.
  - If the hot water is coming out, move the relief valve lever up and down several times, and check the state again.

	<b>WARNING</b>
	● Do not touch the hot water.

#### NOTE:

- If a failure or water leak is found during maintenance, contact the dealer where the hot water system has been purchased.

## Recommendation for regular inspections

To ensure the safe and comfortable use of the CO<sub>2</sub> HEAT PUMP HOT WATER SYSTEM over an extended period, we strongly recommend regular inspections by qualified technicians.

## Inspection and maintenance details

Depending on the installation conditions, usage conditions, or special environments, the degradation and wear of functional components in the water heater may occur more quickly. To prevent malfunctions, please carry out the following checks, cleaning, and maintenance.

#### ■ Confirmation of Installation Conditions

- Water leaks
- Damage to the pipe insulation
- Dirt accumulation on electrical wiring
- Damage or wear to cables and plugs
- Damage to the base or installation floor surface

#### ■ Confirmation of Functional Components

- Inspection of the tank relief valve (as noted)
- Operate "Air purge" using the controller to check if the CO<sub>2</sub>HPU pump is functioning properly (P.33)

#### ■ Cleaning and Maintenance

- Remove sediment from the tank
- Clean the strainer (P.28)
- Flush the water pathways of the CO<sub>2</sub>HPU pump and heat exchanger with water
- Replace consumable parts

## Replacement of consumable parts

#### ■ Relief Valve (PTRV):

- Replacement is necessary due to deterioration of the valve body and the accumulation of deposits, which can lead to malfunction.

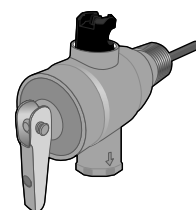

#### ■ Anode Rod:

- This component is used to prevent corrosion of the tank body material.
- It wears out over time, so regular replacement is necessary.





# When Not Using for Long periods

## When not using hot water for 1 to 30 days [Holiday]

When hot water is not used for a certain period due to travel or other reasons, heating operation is suspended with the power of the hot water system remaining ON.

This setting is economical and prevents potential failures or accidents due to powered-off state for long periods.

### Setting the [Holiday] mode

- 1 Press Menu .  
Select [Operation mode] and press Enter .

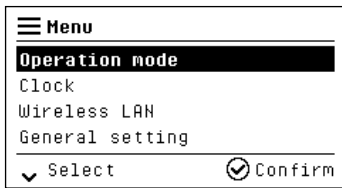

- 2 Select [Holiday] with  , and press Enter .

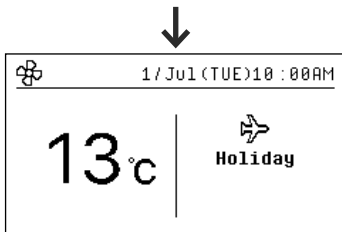
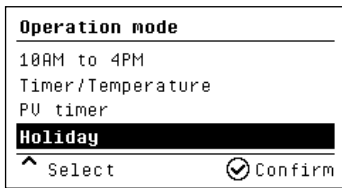

#### NOTE:

- Even while [Holiday] is set, the entire volume in the tank is heated to 63 °C once every seven days to prevent an accident caused by legionella bacteria.
- Since the water is heated to a higher temperature than usual at this time, take care to avoid a burn injury when using hot water.



### WARNING



- Check the water temperature before use. (Failure to do so may result in a burn injury.)
- When using hot water from the water mixing tap or the shower, check the temperature with your hand or fingers beforehand.

### Cancelling the [Holiday] mode

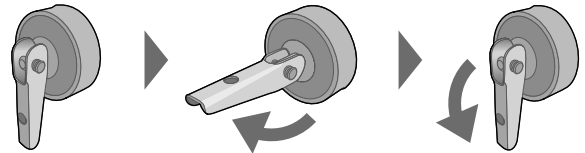

When a long period of time has elapsed after suspension of heating operation, hydrogen gas may have accumulated in the tank. Because of this, open the relief valve (PTRV) of the tank unit and discharge the gas before controller operation. (Refer to P.31. Restore the relief valve to the original position after the discharging of gas is completed.)

Relief valve lever





- 1 Press [BOOST] on the controller.  
• Water to be used on the day is heated.

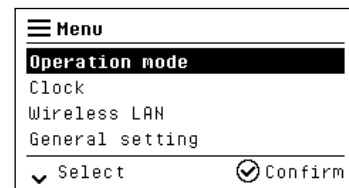

- 2 Press Menu .  
Select [Operation mode] and press Enter .



- 3 Select a desired mode with  , and configure the detailed settings.

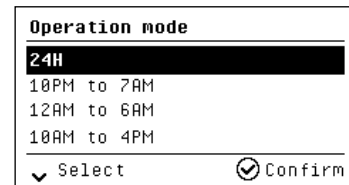

# When not using hot water one month or longer, or turning off the power

Be sure to drain water to prevent an accident caused by legionella bacteria due to change of water quality inside the hot water system, malfunctions of functional parts for plumbing, freezing damage, and other problems. The CO<sub>2</sub>HPU, tank unit, and inside the piping can be kept clean.

## Turning off the power

- 1 Turn [OFF] the earth leakage breaker.
- 2 Remove the power plug from the socket.

## Draining hot water

- 1 Drain the entire hot water in the tank.
  - Since water comes out from all taps, be sure to take waterproof measures in the surrounding area.
  - ① Open the mixing tap, and drain hot water until it is exhausted. Be sure to mix water to make lukewarm water before drainage. (Make water in the tank.)
  - ② Close the mixing tap.
  - ③ Close the water supply main tap\*.
  - ④ Raise the relief valve lever.
    - A certain volume of water comes out from the outlet port of the relief valve. Leave it until no water comes out. Do not lower the relief valve lever while water is being drained. (The tank may be damaged.)
  - ⑤ Remove the strainer.
  - ⑥ Confirm that water no longer comes out from the strainer attachment port. (Up to 80 minutes are taken.)

\*: If the water supply main tap is not mounted at the position in the figure, check with the dealer where the product has been purchased. (Depending on the plumbing work, the mounting position may differ.)
- 2 Drain water remaining in the CO<sub>2</sub>HPU, etc.
  - ⑦ Loosen the drain plugs (three locations) of the CO<sub>2</sub>HPU. (Do not remove the drain plugs.)
    - When a plug is closed because of no water coming out, water may not come out from other plugs, resulting in damage due to freezing in winter.
- 3 When water no longer comes out from the strainer attachment port
  - ⑧ Close the drain plugs (three locations) of the CO<sub>2</sub>HPU.
  - ⑨ Attach the strainer.
  - ⑩ Lower the relief valve lever.

### NOTE:

- To use the hot water again, make preparations according to "First Time Use" (P.15-17) and heat the water after the tank is filled up.

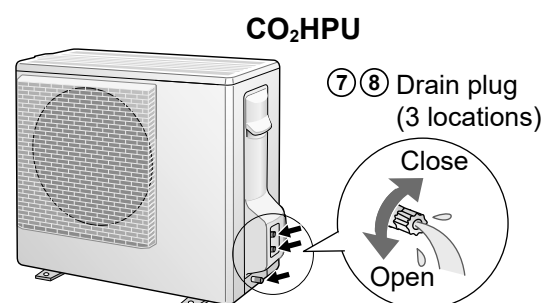
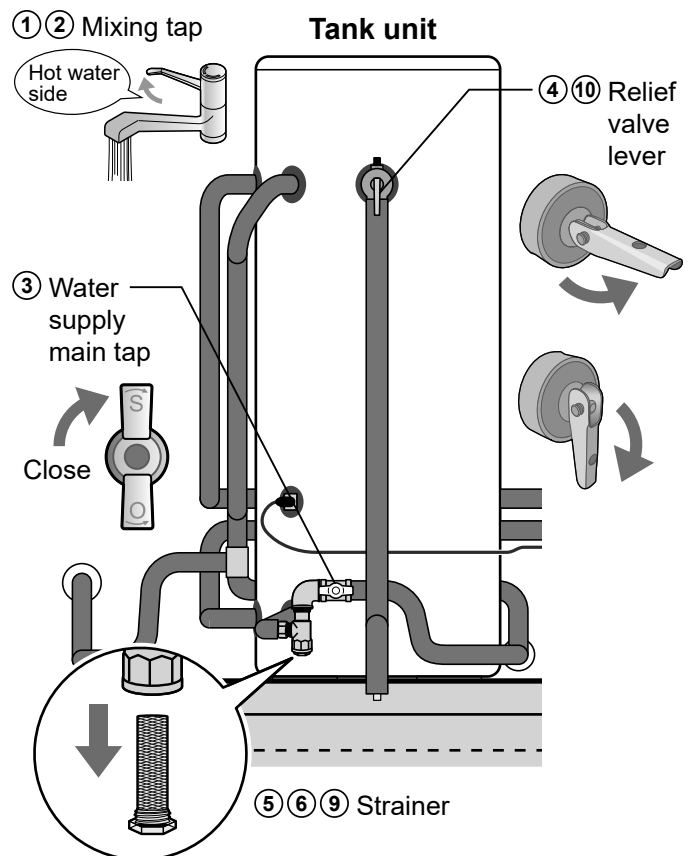
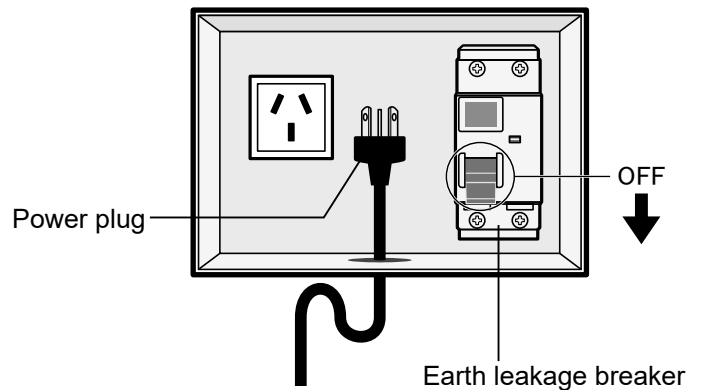

# When power failure has occurred

---

The hot water in the tank can be used, but nothing is displayed on the controller. Heating cannot be performed in this state.

The temperature of the hot water will decrease over time.

- Do not drink the water as it is. Be sure to heat the water once.
- After hot water in the tank is used up, water comes out.

# When power failure continues for 15 days or more

---

- Refer to "When Not Using for Long periods, When not using hot water one month or longer, or turning off the power" (P.31), and drain water from the hot water system.  
Keeping the inside the tank clean eliminates the cause of failure in the hot water system.

# When power failure is restored



---

- Before using the system, make sure that the time display on the controller is correct. Adjust the time if it is shifted. (P.17)  
Note that an unexpected electric fee may be charged if the time is not corrected.

# About heating to prevent the growth of legionella bacteria when power failure is restored

---

- It is reported that an infectious disease called the legionnaire's disease occurs due to legionella bacteria. The governments have set standards for hot water systems to prevent the growth of legionella bacteria. In accordance with the standards, this product automatically heats entire volume in the tank when any of the following conditions is met. Note that the CO<sub>2</sub>HPU may heat water to the maximum temperature of 70 °C, which is higher than the normal hot water temperature.
  - When power failure is restored (when the power plug is removed and attached while the hot system is used)
  - At 12 a.m. midnight every Sunday (as default setting)  
"Day of week" and "Time" to start heating can be changed by Panasonic service engineers.
  - When "Register"  is pressed in the "Clock" menu on the controller

 <b>WARNING</b>	
	<ul style="list-style-type: none"><li>● <b>Check the water temperature before use.(Failure to do so may result in a burn injury.)</b><ul style="list-style-type: none"><li>• When using hot water from the water mixing tap or the shower, check the temperature with your hand or fingers beforehand.</li></ul></li></ul>

# When water outage has occurred

## Close the water supply main tap

- Hot water and water in the tank may become muddy due to dirt, etc. accumulated in the water supply pipe.
- Hot water cannot be supplied during water outage.

Water supply main tap

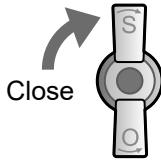

## When water outage is restored

After recovery, rinse off dirt accumulated in the pipe during water outage, and then use hot water.

- 1 Open the water side of the mixing tap, and let water flow sufficiently.
  - Rinse off the dirt not to allow the dirt to enter the tank. When dirty water no longer comes out, close it.

1 Mixing tap

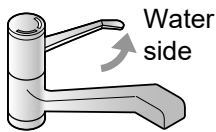

- 2 Open the water supply main tap.
  - Rinse off the dirt not to allow the dirt to enter the tank. When dirty water no longer comes out, close it.
- 3 Raise the relief valve lever.
  - Confirm that hot water comes out from the outlet port of the relief valve. (approx. 10 seconds)
- 4 Lower the relief valve lever.
  - When water stops coming out from the outlet port of the relief valve, hot water can be supplied.

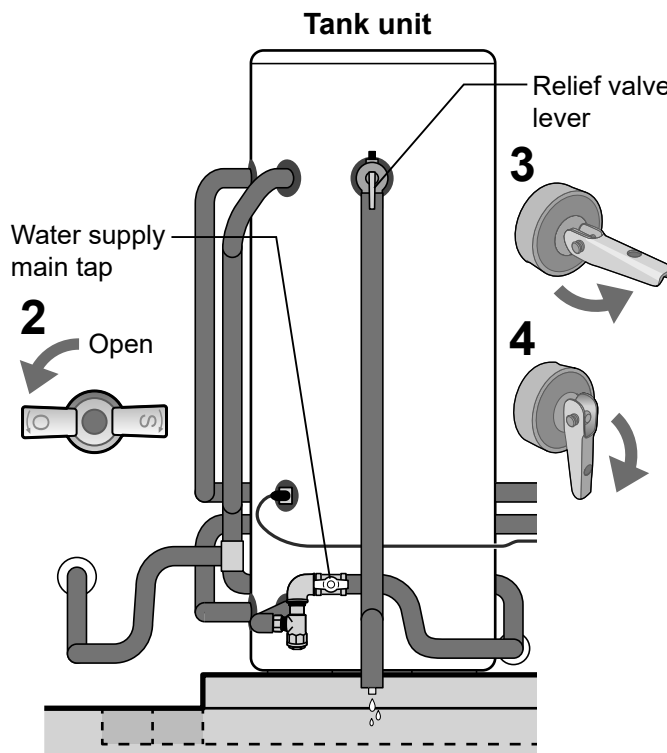

## Air-purging the piping using the controller

When air accumulates inside the piping of the CO<sub>2</sub>HPU due to the effect of water outage, water may not flow normally, resulting in heating suspension. Perform the following operation.

- 1 Press Menu . Select [General setting] with , and press Enter .

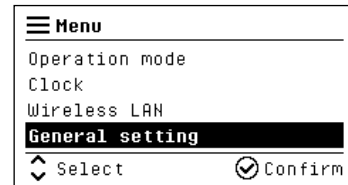

- 2 Select [Air purge] with , and press Enter .

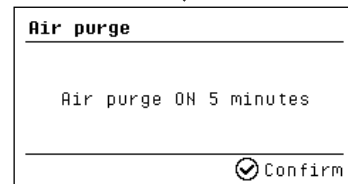
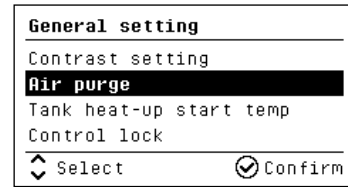

# Troubleshooting

## Symptom & cause

• These are not errors.

Symptom	Cause	Page
<b>■ Hot water supply</b>		
Hot water does not come out.	<ul style="list-style-type: none"> <li>● Is the water supply main tap closed? → Open it.</li> </ul>	P.15
	<ul style="list-style-type: none"> <li>● Has water outage occurred? → Take necessary measures after recovery.</li> </ul>	P.33
	<ul style="list-style-type: none"> <li>● Is the water supply pipe frozen? → Wait until the freezing condition is remedied.</li> </ul>	—
Enough hot water does not come out.	<ul style="list-style-type: none"> <li>● Is dust, etc. clogged in the strainer (filter) on the water supply port of the tank? → Refer to "Cleaning the tank two or three times a year", and clean the strainer (filter).</li> <li>● When enough hot water still does not come out even after cleaning, contact the dealer where the product has been purchased.</li> </ul>	P.28
Hot water is not hot enough.	<ul style="list-style-type: none"> <li>● Water remaining in the pipe may come out. → Wait until hot water comes out.</li> </ul>	—
	<ul style="list-style-type: none"> <li>● When hot water is not much used for several days, re-heating of the tank may not be performed, and the temperature of the entire tank decreases. → Perform re-heating with [BOOST].</li> <li>● If a power outage occurs for an extended period during heating operation, the tank may not be fully heated. → Perform re-heating with [BOOST].</li> </ul>	P.19
Hot water temperature is higher than usual	<ul style="list-style-type: none"> <li>● To prevent the growth of legionella bacteria, water may be heated automatically to a higher temperature than usual. As a result, the temperature of the hot water in the tank may rise.</li> </ul>	P.32
Hot water temperature fluctuates, or cold water comes out.	<ul style="list-style-type: none"> <li>● This symptom occurs when the volume of hot water from the mixing tap fluctuates, for example, when hot water is used at two or more locations. → Perform re-heating with [BOOST].</li> <li>● This symptom may occur when hot water is flowed out during heating.</li> </ul>	—
<b>■ Controller</b>		
The controller does not light up.	<ul style="list-style-type: none"> <li>● Is the earth leakage breaker turned "OFF" or is the power plug disconnected? → Make sure that the tank is filled up, and then turn on the power.</li> </ul>	P.16
The controller screen display is difficult to see. (Afterimage remains, the entire display looks blackish, etc.)	<ul style="list-style-type: none"> <li>● Due to the nature of LCD, the display may look dark in cold weather. The contrast (shading) of the controller screen display can be adjusted.</li> </ul>	P.27
Nothing is displayed on the controller.	<ul style="list-style-type: none"> <li>● The controller may turn off temporarily (approx. 10 seconds) due to lightning strike, etc.</li> </ul>	—
The tank temperature indication on the controller is low although the hot water is not used.	<ul style="list-style-type: none"> <li>● Even if hot water is not used, the temperature of the hot water may decrease due to heat dissipation of the tank.</li> </ul>	P.18
Heating is performed although the hot water is not used.	<ul style="list-style-type: none"> <li>● Heating may be performed for freeze protection.</li> </ul>	P.19
	<ul style="list-style-type: none"> <li>● To prevent the growth of legionella bacteria, water may be heated automatically to a higher temperature than usual. As a result, the temperature of the hot water in the tank may rise.</li> </ul>	P.32

## Symptom & cause

- These are not errors.

Symptom	Cause	Page
<b>■ Heating</b>		
Hot water has run out, or is running out.	<ul style="list-style-type: none"> <li>● The volume of hot water used is greater than the volume of water that has been set as a condition for heating automatically. → Perform re-heating with [BOOST] early. It is recommended to review the operation mode setting.</li> </ul>	P.18 - 19
Not much hot water is used, but the hot water shortage occurs.	<ul style="list-style-type: none"> <li>● When hot water is not much used for several days, re-heating of the tank may not be performed, and the temperature of the entire tank decreases. → Perform re-heating with [BOOST]. → Set the heating start temperature to higher degrees. Re-heating will become easy.</li> </ul>	
Shortage of hot water	<ul style="list-style-type: none"> <li>● The volume of hot water used is greater than the volume of water that has been set as a condition for heating automatically. → Perform re-heating with [BOOST] early. It is recommended to review the operation mode setting.</li> </ul>	
Hot water remains unused.	<ul style="list-style-type: none"> <li>● The volume of hot water used is less than the volume of water that has been set as a condition for heating automatically. → It is recommended to review the operation mode setting.</li> </ul>	
Water is heated to a temperature higher than usual. (The controller indicates 63 °C or higher.)	<ul style="list-style-type: none"> <li>● To prevent the growth of legionella bacteria, water may be heated automatically to a higher temperature than usual. As a result, the temperature of the hot water in the tank may rise.</li> </ul>	P.32
<b>■ Product units and operation sound</b>		
Water leakage occurs from the drain port of the tank unit relief valve.	<ul style="list-style-type: none"> <li>● While heating is in progress (The heating symbol  on the controller is lit): The water in the tank expands, the relief valve operates, and the water comes out. This is not a malfunction.</li> <li>● Other than while heating is in progress (The heating symbol on the controller is unlit): → Move the relief valve lever up and down several times, and then lower the relief valve lever to check that the water stops. → When the water does not stop even after the above operation is performed, contact the dealer where the product has been purchased.</li> <li>● If the water leakage is left as is, the water bill or electricity bill may go up due to lowered temperature of hot water or shortage of hot water.</li> </ul>	P.29, P.48
Water or steam comes out from the CO <sub>2</sub> heat pump unit.	<ul style="list-style-type: none"> <li>● Dew condensation water forms during operation. When defrosting is performed in winter, water or steam is generated. This is not a malfunction.</li> </ul>	—
Water is leaked from the bottom of the CO <sub>2</sub> heat pump unit.	<ul style="list-style-type: none"> <li>● When the drain hose is waved or has rising slope, dust may be clogged, causing water leakage. Contact the dealer where the product has been purchased.</li> </ul>	
The rear of the heat pump unit becomes whitish due to frost.	<ul style="list-style-type: none"> <li>● Frost may form during operation in winter.</li> </ul>	
A cracking sound is heard from the CO <sub>2</sub> heat pump unit in winter, etc.	<ul style="list-style-type: none"> <li>● Immediately after the heating operation starts, the temperature of the aluminium part on the rear side rapidly decreases, and a sound as if generated ice bursts may be heard. This is not a malfunction.</li> </ul>	

# Troubleshooting (Continued)

## Symptom & cause

• These are not errors.

Symptom	Cause	
<b>■ Product units and operation sound</b>		
		Page
The sound from the CO <sub>2</sub> heat pump unit becomes louder.	<ul style="list-style-type: none"> <li>● A sound is heard during heating operation or freeze protection operation.</li> <li>● When the ambient temperature is low in winter, etc., the operation sound may become louder.</li> <li>● A defrosting operation sound is heard. (Operation and suspension are repeated.)</li> </ul>	—
A sink or other areas around the water mixing tap become blue.	<ul style="list-style-type: none"> <li>● This symptom occurs due to copper ions contained in the hot water. No harm to human body.</li> </ul>	P.11
The hot water is turbid in white.	<ul style="list-style-type: none"> <li>● This symptom occurs since the air dissolved in water forms tiny bubbles. It is normal.</li> </ul>	
The hot water is oily or smells.	<ul style="list-style-type: none"> <li>● When using the system for the first time, oil or odour derived from plumbing work may be mixed in the hot water, however, they will disappear after a while. If you are concerned, please contact the dealer where the product has been purchased.</li> </ul>	—
An impulsive sound is heard when the hot water or water is stopped.	<ul style="list-style-type: none"> <li>● This sound occurs in a region where water pressure is high. → This symptom can be remedied by installing a water hammer prevention device or using a mixing tap of single lever equipped with a water hammer mitigation mechanism. Request the dealer where the product has been purchased.</li> </ul>	

## Q & A

• These are not errors.

Question	Answer	
<b>■ What measures should be taken?</b>		
		Page
When replacing the tap...	<ul style="list-style-type: none"> <li>● Even if the water supply main tap is closed, the hot water in the tank may come out. When replacing the tap or packing, contact the dealer where the product has been purchased</li> </ul>	—
When discontinuing use of the CO <sub>2</sub> heat pump hot water system...	<ul style="list-style-type: none"> <li>● Use the controller or the dedicated app to reset the settings and delete usage and wireless LAN connection information.</li> </ul>	P.16, P.77
When transferring or disposing of the unit...	<ul style="list-style-type: none"> <li>● Turn off the power to the CO<sub>2</sub> heat pump hot water system and drain the water.</li> </ul>	P.31

# When the controller indicates an error

- Check the following and take appropriate measures.

Controller display	Measures to be taken
--------------------	----------------------

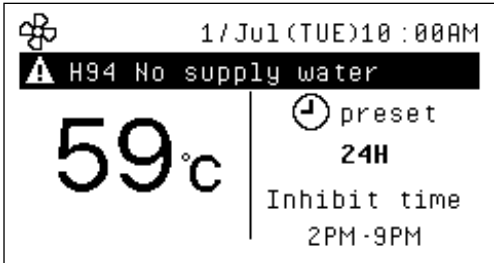

Error code	Error description
H94	No supply water

- Turn [OFF] the earth leakage breaker, and turn off the power for approx. one minute to recover from the error state. If the problem is not solved, take the following measures.
- Take necessary measures according to the procedures described in "First Time Use," "Filling up the tank," and "Discharge the air from the CO<sub>2</sub> heat pump unit" in this manual. (Refer to P.15.)
- The water supply pressure may be extremely low due to the main water supply tap of the tank unit being closed or a water outage. Take an appropriate measure to make the water supply pressure normal, such as by opening the water supply main tap.
- Water supply may be abnormal due to freezing of pipe or other reasons. Contact the dealer where the product has been purchased, and request an anti-freeze measure.

- If the problem persists, or an error other than the above indication appears, or water leakage occurs, check [Failure history], and notify the dealer where the product has been purchased.

## Checking [Failure history]

Check the error indication on the control screen, and contact the dealer where the product has been purchased.

- 1 Press Menu . Select [Failure history] with , and press Enter .

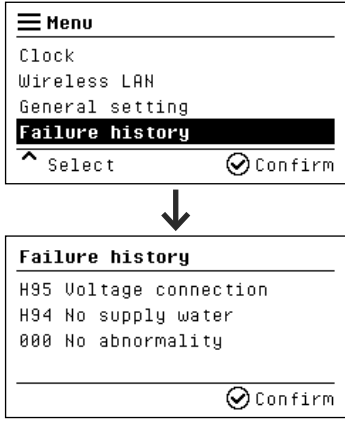

Up to three errors are displayed. The latest error is always displayed on top.  
If no error exists, [000 No abnormality] is displayed.

- 2 Press Enter to return to the main screen.

### Typical error indications and overview

Error code	Error description
H76	RC-HPU communication
H11	WLAN disconnection
F38	Tank temp sensor
F19	Outgoing water temp
F67	Circulation pump
F15	Fan motor locked
H95	Voltage connection

- NOTE:**
- Indications other than the above may be displayed. In that case, contact the dealer where the product has been purchased, or the Panasonic customer desk.

# Installation manual

## Contents

Page

<b>Determining the Installation Location</b>	<b>39</b>
Work flow	39
<b>1. Preparation</b>	<b>40</b>
Preparing required members	40
Precautions on construction	42
<b>2. Mounting</b>	<b>44</b>
Transporting and unpacking the product (tank unit)	44
Transporting and unpacking the product (CO <sub>2</sub> HPU)	45
Installing the tank unit	46
Installing the CO <sub>2</sub> heat pump unit (CO <sub>2</sub> HPU)	47
<b>3. Plumbing</b>	<b>48</b>
Performing drainage work	48
Pre-assembling the piping members	50
Laying the water supply pipe	51
Laying the hot water supply pipe	51
Laying the pipe of the CO <sub>2</sub> HPU	52
Performing warm-keeping construction work	53
<b>4. Wiring</b>	<b>54</b>
Installing the controller	54
Connecting the controller to the CO <sub>2</sub> heat pump unit	56
Installing the tank sensor	57
<b>5. Commissioning</b>	<b>58</b>
Filling up the tank	58
Cleaning the tank to confirm no problems	59
Checking the capacity of the power facility for conformity	59
Turning on the power	59
Checking the controller	59
Setting the date and time	59
Performing a test run for heating	60
<b>Adding an Option</b>	<b>61</b>
Linking up with solar power generation	61
<b>Construction Check List</b>	<b>62</b>

# Determining the Installation Location

Refer to the three construction examples (A, B, C) on the next page, and determine the installation location. The power cable (2.1 m), controller cable (1.3 m), and tank sensor (2.8 m) have been mounted on the product. No new installation is required. Install the hot water system within the range each unit can be connected to each other.

(If the connection range is exceeded, CO<sub>2</sub>HPU and controller cannot be installed.)

- Secure space required for maintenance to use the hot water system for long periods with a peace of mind.
- Hot water or water in the tank unit and CO<sub>2</sub>HPU needs to be discharged completely. Perform drainage work according to the regulations of the country and local governments.
- The anode rod of the tank unit may be replaced during periodical inspections. Secure replacement space (1.5 m) above the tank.
- Prepare correct members for each installation process, and secure installation quality.

## Work flow

- The following shows the standard construction work flow and processes. Depending on the condition, the order of processes may be switched. Before construction work, be sure to read the details described in this manual.

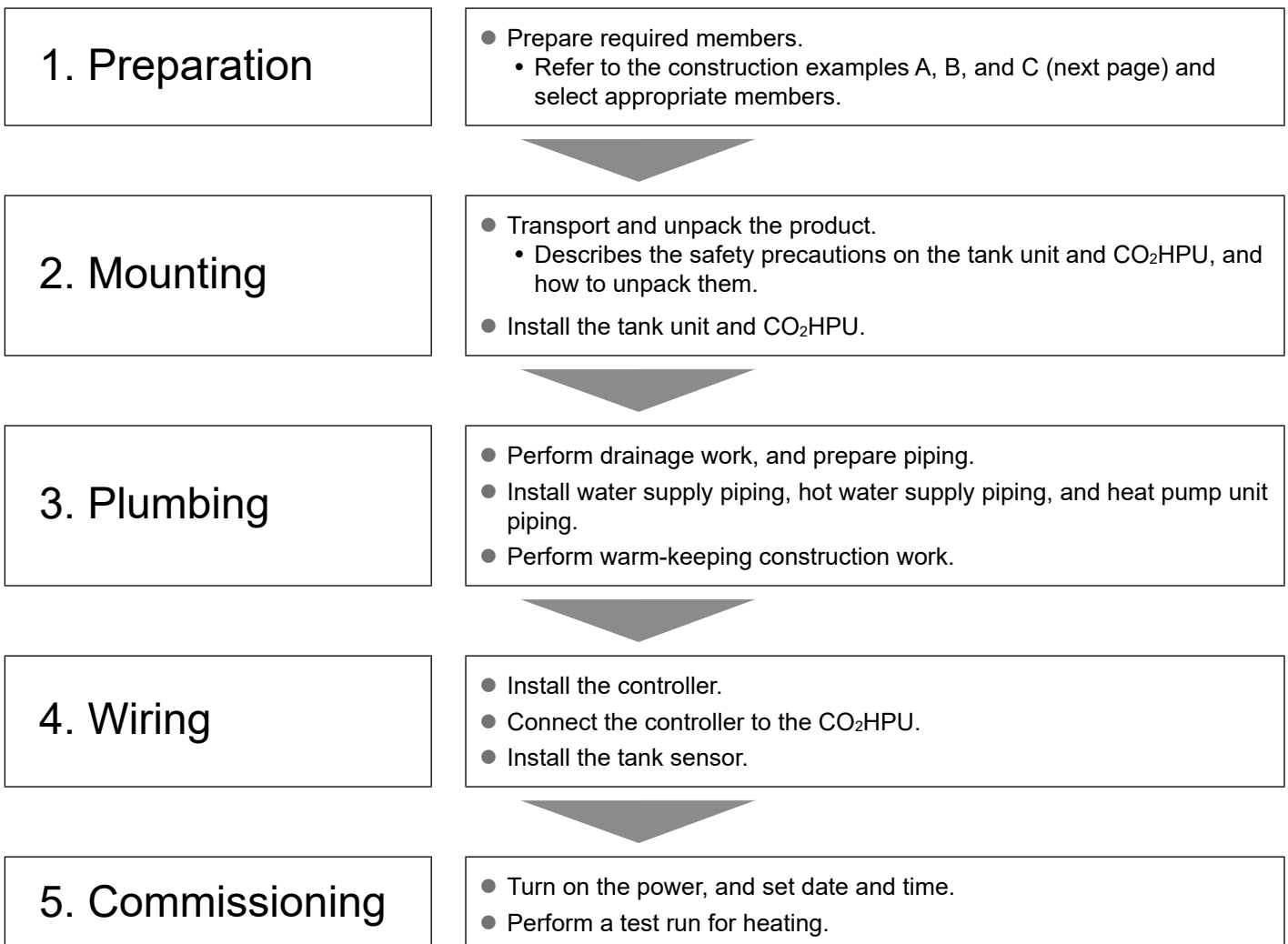

# 1. Preparation

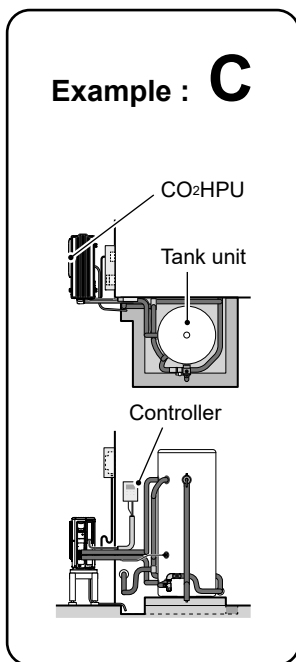
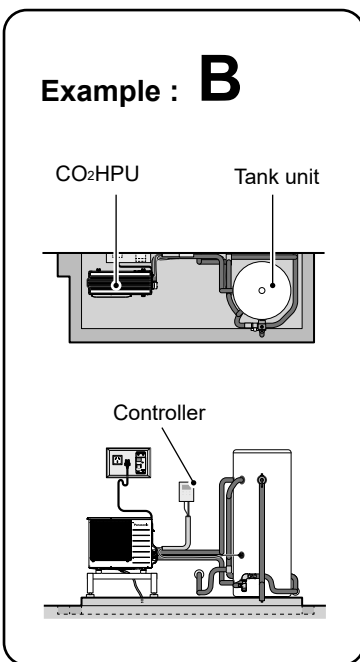
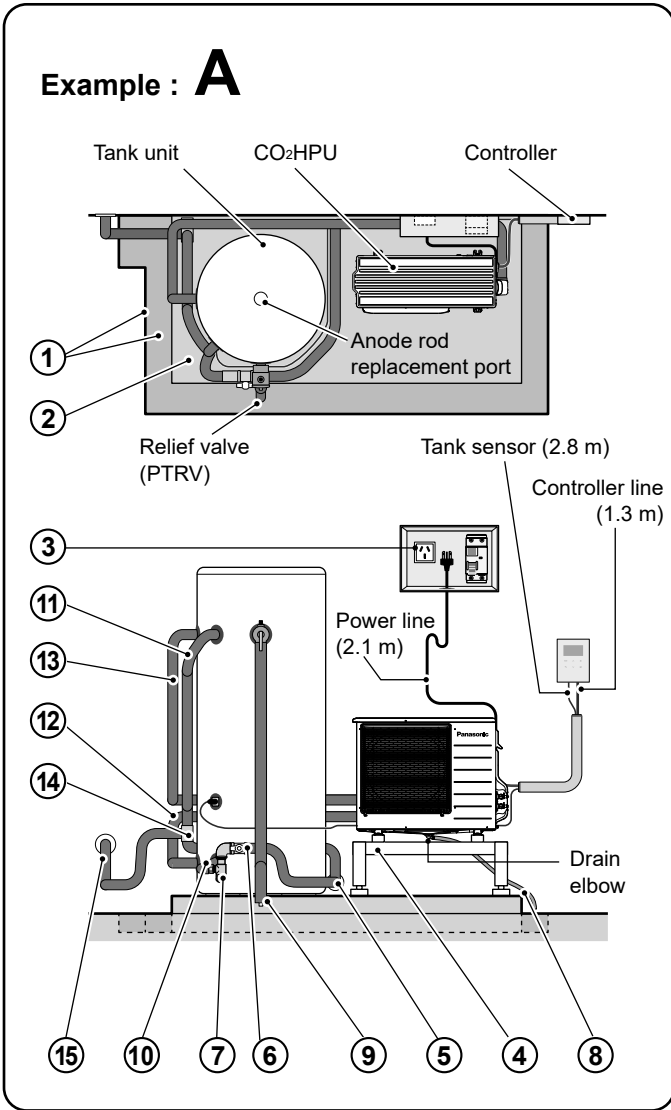

## Preparing required members

Select members and perform construction work according to each item shown in the figure.

### ■ Items for installation

Item	Requirement
① <b>Drainage ditch, waterproof wall</b>	Perform construction work correctly according to the laws and regulations of each local government.
② <b>Installation floor surface</b>	
③ <b>Power supply box</b>	Install it at a location where operation of the earth leakage breaker and insertion/removal of the power plug are easy, and the power plug state can be checked from a remote location.
④ <b>High-level base</b>	Place the CO <sub>2</sub> HPU on a level surface to ensure stable operation.
⑤ <b>Water supply pipe</b>	Secure a water supply pressure of 200 kPa or more for stable operation for the CO <sub>2</sub> HPU.
⑥ <b>Water supply main tap</b>	Providing any specific requirements and limitations relating to the installation, operation, periodic inspection and maintenance of the appliance to ensure continued safety.
⑦ <b>Strainer</b>	
⑧ <b>Drain hose</b>	Make sure to install it except in cold climates.

### ■ Preparations of the piping members

Item	Requirement
⑨ <b>Drainage pipe of the relief valve</b>	To prevent inclusion of foreign matter, protect the end of the pipe using a plastic bag, etc. until connection is made. This prevents failures such as water leak or clogging.
⑩ <b>Tank water inlet connection pipe</b>	
⑪ <b>Tank hot water outlet connection pipe</b>	Do not perform burying work for the CO <sub>2</sub> HPU piping. (Heating temperature may be lowered.)
⑫ <b>CO<sub>2</sub>HPU water pipe</b>	
⑬ <b>CO<sub>2</sub>HPU hot water pipe</b>	Do not connect check valves to the CO <sub>2</sub> HPU piping. (A malfunction may occur.)
⑭ <b>Hot water and water mixing control valve</b>	
⑮ <b>Hot water supply pipe</b>	

- For electrical work, follow the wiring rules AS/NZS 3000, national regulation, legislation and this installation instructions.  
An independent circuit and single outlet must be used. If electrical circuit capacity is not enough or defect found in the electrical work, it will cause electrical shock or fire. (When there is any uncertain point, contact the member manufacturers for details, and perform construction work.)
- This appliance's installation shall conform to the Plumbing Code of Australia (PCA).

Constraints or requirements	Additional Notes
<ul style="list-style-type: none"> <li>• Drainage capacity: 25 L/min</li> </ul>	<ul style="list-style-type: none"> <li>• A drainage pipe equipped with a hopper can be used for the construction work.</li> </ul>
<ul style="list-style-type: none"> <li>• Inclination of the tank unit filled up with water: Horizontal, using a level</li> </ul>	<ul style="list-style-type: none"> <li>• Make sure that the product has sufficient earthquake-resistance when filled up.</li> </ul>
<ul style="list-style-type: none"> <li>• Electrical capacitance: The specification exceeds the maximum current value.</li> <li>• A dedicated earth leakage breaker (RCD) is installed.</li> <li>• Earth leakage breaker electric capacity: 20A</li> </ul>	<ul style="list-style-type: none"> <li>• Make sure that electrical capacitances of all wiring devices have sufficient margins with respect to the maximum current of the CO<sub>2</sub>HPU.</li> </ul>
<ul style="list-style-type: none"> <li>• Allowable loading capacity: 50 kg or more</li> <li>• Inclination when CO<sub>2</sub>HPU is installed: Within 3°</li> </ul>	<ul style="list-style-type: none"> <li>• Make sure to perform a test run to check the operation sound of the CO<sub>2</sub>HPU.</li> <li>• Condensed water from the bottom of the product must be able to drain smoothly. Base height: 0.1 m or more</li> </ul>
<ul style="list-style-type: none"> <li>• Pressure reducing valve on the water supply side: Install 500 kPa.</li> <li>• Relief valve on the water supply side: Install 600 kPa.</li> </ul>	<ul style="list-style-type: none"> <li>• This appliance's installation shall conform to the Plumbing Code of Australia (PCA).</li> </ul>
<ul style="list-style-type: none"> <li>• Attaching the strainer: Attach it between the water supply main tap and tank in such a way that it can be removed downward.</li> <li>• Recommended filter: Stainless steel, 25-mesh equivalent, Opening Φ 2 mm or less, Area: 100 mm<sup>2</sup> or more</li> </ul>	<ul style="list-style-type: none"> <li>• Install the strainer in such a way that the tank water can be drained from the opening when the filter is removed, and the drained water can be led to the drainage ditch.</li> <li>• Be sure to attach the filter lower than the pipe so that attached dust does not drop and mix into the pipe when the filter is removed.</li> </ul>
<ul style="list-style-type: none"> <li>• Material: Weatherproof, low-density PE flexible pipe</li> <li>• Connection port: Inner diameter Φ15 mm or Φ16 mm</li> </ul>	<ul style="list-style-type: none"> <li>• Install the pipe in such a way that condensed water can be smoothly drained from the bottom of the product, and determine the length.</li> </ul>

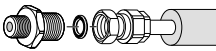
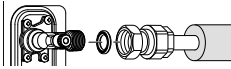
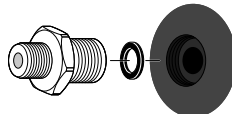
Pipe type	Connection method	Nipples and seals
<ul style="list-style-type: none"> <li>• Water supply copper pipe or water supply heat-resistant rubber hose</li> <li>• Copper pipe diameter: Φ12.7 mm to Φ15.0 mm</li> <li>• Hose: Same inner diameter as that of copper pipe</li> </ul>	<ul style="list-style-type: none"> <li>• Copper pipe diameter: G1/2 union nut</li> <li>• Hose: hose band</li> </ul>	<ul style="list-style-type: none"> <li>• Relief valve outlet: R1/2-G1/2 nipple, Sealing material: PTFE tape, flat plate gasket 1/2</li> <li>• Hose: R1/2 hose nipple</li> </ul> 
<ul style="list-style-type: none"> <li>• Water supply copper pipe</li> <li>• Copper pipe diameter: Φ12.7 mm to Φ15.0 mm</li> </ul>	<ul style="list-style-type: none"> <li>• Copper pipe diameter: G1/2 union nut</li> </ul> 	<ul style="list-style-type: none"> <li>• Directly attaching to the tank unit (water supply port, hot water supply port, CO<sub>2</sub>HPU: Common to four locations of water side and hot water side)</li> <li>• G1/2-G3/4 nipple (4 pcs)</li> <li>• Sealing material: Flat plate gasket 3/4 (4 pcs)</li> </ul>  <ul style="list-style-type: none"> <li>• Connection of CO<sub>2</sub>HPU pipe (CO<sub>2</sub>HPU: Common to four locations of both water side ends and both hot water side ends)</li> <li>• Nipple: Not required</li> <li>• Sealing material: Flat plate gasket 1/2 (4 pcs)</li> </ul>
<ul style="list-style-type: none"> <li>• Determine the piping specifications according to the building construction specifications at the site.</li> </ul>		

# 1. Preparation (Continued)

## Precautions on construction

Following are constraint conditions to use the CO<sub>2</sub> heat pump hot water system for household use. Be sure to observe the conditions.

- According to the laws and regulations including ordinances of local governments, the construction work can be performed only by a qualified piping construction engineer or electrical construction engineer. The following standards need to be observed. For details, refer to the standards.
  - AS/NZS 3000 – Electric equipment standard
  - AS/NZS 3500 – Piping and drainage piping standard
  - AS/NZS 2712.2007 – Heat pump hot water system design and structure standard
  - AS/NZS AS 3498 2020 – Water heater and hot water storage tank standard
  - AS/NZS 60335.1 – General safety standard for household appliances
  - AS/NZS 60335.2.21 – Safety standard for storage water heaters
  - AS/NZS 60335.2.40 – Safety standard for heat pumps
- The qualified piping construction engineer or electrical construction engineer needs to follow guidelines related to occupational safety and health, and general rules established by relevant industry associations.
- In any circumstances, read and understand this manual, and perform installation work correctly and safely.
- The Panasonic manufacturing division determines that only the system made by connecting one CO<sub>2</sub> heat pump unit (hereafter referred to as CO<sub>2</sub>HPU), one tank unit, and one controller among model numbers shown on the front page of this manual using appropriate members described in this manual are covered under warranty.
- This system is designed as a hot water system for household use in Australia or New Zealand. It is not intended for business use or other purposes such as hot-water heating. Therefore, using the system in applications other than the hot water system for household use is not included in the warranty.
- Piping used for water supply, hot water supply, and drainage of this system and other functional parts and equipment must comply with the Plumbing Code of Australia (PCA). The construction work needs to be carried out in accordance with laws and regulations established by the country or local governments.

- Make sure that the water quality satisfies the requirements shown in the table below. Prepare water complying with the water quality standard for drinking water. Even if the water complies with the water quality standard, water containing lots of chlorine ions, lime content, or other impurities may cause a malfunction. Note that a case judged that the requirements are not met is not covered by the product warranty.

Water quality standards	
Total Hardness (CaCO <sub>3</sub> )	< 200 mg/L or ppm
Chloride	< 200 mg/L or ppm
pH Level	Min. 6.5 to Max. 8.5

- Observe the piping conditions described in this manual to stabilize the temperature and pressure of hot water and prevent heat dissipation loss.
- Make sure that the water supply pressure is 200 kPa or more. Otherwise, the CO<sub>2</sub>HPU may malfunction.
- Be sure to use the relief valve (PTRV) mounted on the tank unit. (setting pressure: 850 kPa or less) Note that modifying this part may violate laws and regulations.
- Install a detachable water supply pipe on the water supply port of the tank unit using a tool. Connect the water supply pipe alone to the tank unit, and install a specified strainer and water shut-off valve on the water supply side. (for maintenance)
- The water supply passage of the water supply pipe needs to have a pressure reducing valve (pressure setting: 500 kPa or less) and relief valve on the water supply side (pressure setting: 600 kPa or less) installed.
- In maintenance and periodical inspections, cleaning the strainer and tank is important. Keeping the tank clean eliminates the cause of failure. A dedicated water supply main tap is required to drain water from the tank by cleaning the strainer and removing the water supply port of the tank unit.
  - Specifications of a recommended strainer: Stainless-steel strainer with an opening of  $\Phi 2$  mm in size, and a strainer area of 2,100 mm<sup>2</sup> or more 25-mesh equivalent

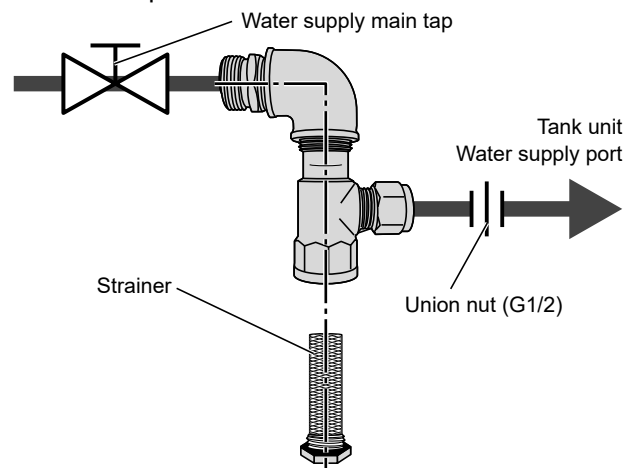

- In coastal regions, install the system in the following locations. (Otherwise, a malfunction may occur.)
  - Location not exposed to seawater or sea breeze
  - Well-drained location
  - Location where salt content, etc. attached on the main unit is thoroughly washed away by rain water.

[Location not exposed to seawater or sea breeze]

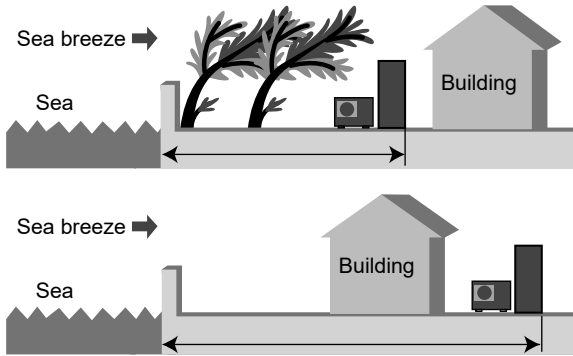

Install the heat pump unit at a location that satisfies the following conditions with the consent of the customer.

- Avoid installation at the following locations. (Otherwise, the unit may not operate normally.)
  - Indoors or closed location.
  - Location with the lowest temperature below  $-10^{\circ}\text{C}$
  - Location with high humidity or close to flame or combustibles
  - Location directly exposed to typhoon or strong wind
  - Special location such as hot spring resorts
- Install the unit at a location that is not affected by water flow, and set up a mechanism allowing for waterproof treatment and drainage.
  - Guide the drained water to the drain port.
- Install the unit at a location that allows sufficient space to be secured around the unit for loading and unloading of packages, piping work, maintenance and inspection, and performance maintenance.

### ■ Heat pump unit installation location

Construction workers must observe and consider the following.

#### NOTE:

When the heat pump unit is installed near neighborhood houses, the noise and vibration generated during operation of the unit may cause trouble to others. Avoid installation at the following locations.

- Location near a bedroom or window of neighborhood houses.
- Location near air vents of neighborhood houses, or where noise of the unit may enter
- Location where reverberation sounds from walls or fences reach the rooms

- If the vibrations during operation concern you, take appropriate measures such as installing a vibration-proof rubber on the stand of the heat pump unit.
- Observe noise-related environmental standards, and regulations of each local government.

[Height difference from the hot water supply tank]

- Check the piping conditions in case of height difference before determining the installation location.

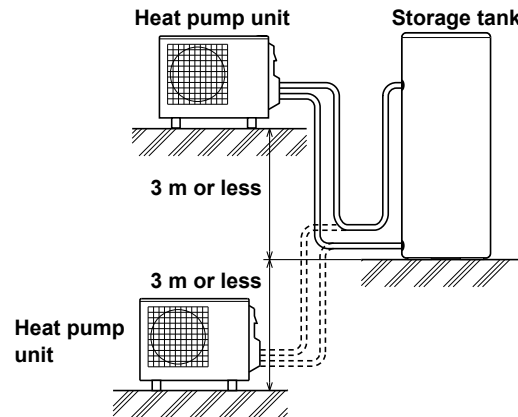

- Since cold air is blown out during operation, avoid installation at a location that may affect the surroundings.
- Install the heat pump unit at a well-ventilated location where there is no interference such as accumulated snow.
- Install the CO<sub>2</sub>HPU at least 3 m away from the antennas of TV or wireless devices, and at least 2 m away from the main units of TV and wireless devices and their cables.
- Do not install the unit at a location with a high concentration of hydrogen sulfide, or oily location with machine oil, etc. (Doing so may cause a malfunction to the heat pump unit.)
- Avoid installation at a location where strong wind constantly blows. (The fan rotates at high speed, which may cause a failure or damage to the unit.)
- Do not install the unit near an air supply and exhaust pipe of burning equipment. (Doing so may cause frost to form.)

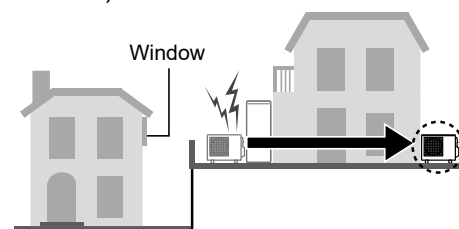

Avoid installation at a location where the operation sound may cause trouble to neighborhood. (The CO<sub>2</sub>HPU can be installed at a location away from the tank unit by conducting piping, wiring, and power supply construction work.)

# 2. Mounting

## Transporting and unpacking the product (tank unit)

Since the tank unit is a heavy load, handle the unit carefully considering the following precautions to secure safety of workers and prevent failures of unit.

### CAUTION

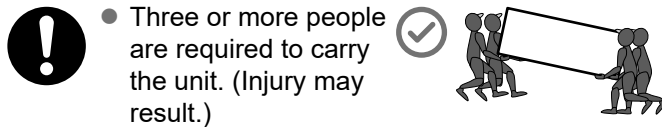

- Three or more people are required to carry the unit. (Injury may result.)

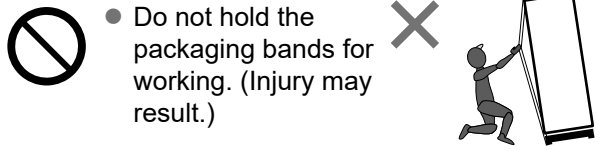

- Do not hold the packaging bands for working. (Injury may result.)

### NOTE:

Insert claws of the forklift in the gap of the lower wood frame before working. Handle the forklift and other machinery safely in a prescribed method. (Injury may result.)

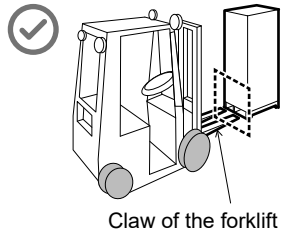

Claw of the forklift

## Bundled items and how to unpack them

- The relief valve and anode rod bundled with the product have been installed on the product.
- Three or more people are required for unpacking work. After carrying the unit to the side of the installation floor, remove the packaging bands. (If the bands are removed beforehand, the unit cannot be carried.)

**1** Remove the packaging bands (four locations).

**2** Remove the side cover, top cover, and cushioning material.

**3** With three or more people, hold the body of the product and tilt it slightly to remove all packaging materials and wooden frames.

**4** Carefully place the product on the installation floor surface to avoid scratching or soiling it.

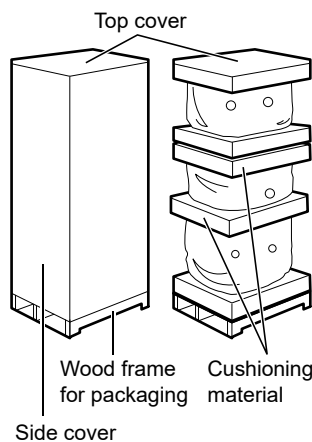

## Precautions for handling the load of product

- Do not stack the unit by two or more stages for storage. Use ropes or similar to support the unit from the side, and exercise caution not to tip over the unit.

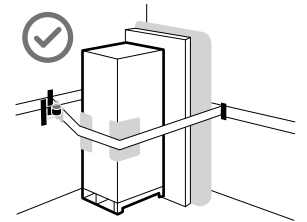

- Be careful during work not to be involved in transport accidents shown below. Do not handle the load in a wrong manner during work. If a transport accident occurs or wrong work is discovered, be sure to report to the owner of the load. Take appropriate measures by following the instructions of the owner of the load.

- Do not allow another load to make contact with the unit.

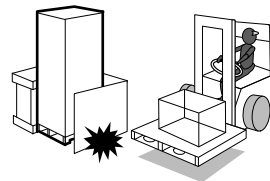

Curing protective board

- Do not laydown the unit.

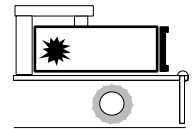

- Do not use a clamp lift.

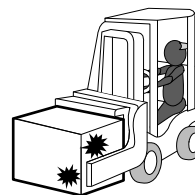

- Do not have an impact on the unit by laying it down.

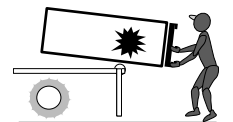

- When handling the unit with machinery, do not allow the machine to make contact with the unit. Do not allow the unit to make contact with the ceiling of the loading platform.

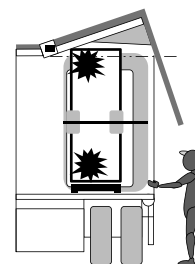

- Do not tip over the unit.

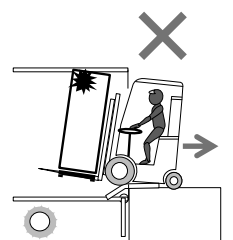
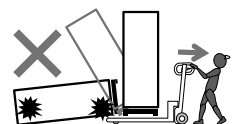

# Transporting and unpacking the product (CO<sub>2</sub>HPU)

Since the tank unit is a heavy load, handle the unit carefully considering the following precautions to secure safety of workers and prevent failures of unit.

## CAUTION



Must do

- Two or more people are required to carry the unit. (Injury may result.)

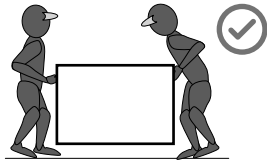

Don't do

- Do not hold the packaging bands for working. (Injury may result.)

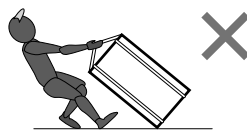

Must do

- Be sure to give the owner's operation & installation manual to the customer. These manuals are necessary to use the hot water system correctly and safely.

## Bundled items and how to unpack them

- The following a), b), and c) are included in the packaging.

a) Owner's operation & installation manual

b) Drain elbow

c) Power cable: Attached on the product.

- Two or more people are required for unpacking work. After carrying the unit to the side of the high-level base for installation, remove the packaging bands. (If the bands are removed beforehand, the unit cannot be carried.)

- Remove the packaging bands (four locations).
- Remove the side cover, top cover, and rear cover in this order.
- Two or more people shall hold the handle of the product and lift it. Then remove the bottom cover.
- Grip the handle of the product and transport it up to the installation high-level base.

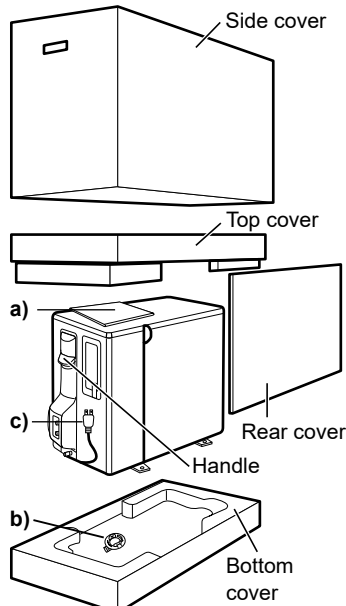

## Precautions for handling the load of product

- Stack the products in a standing position. Stacking is possible by up to three stages. Do not stack the products in parallel crosses. (Doing so may damage the unit.)

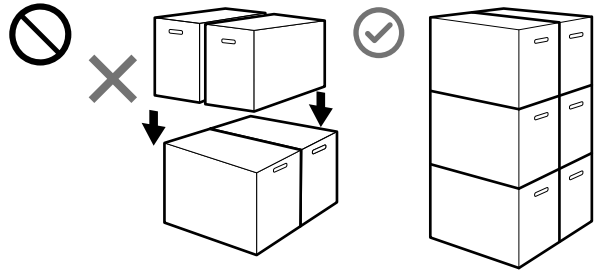

- Be careful during work not to be involved in transport accidents shown below. Do not handle the load in a wrong manner during work. If a transport accident occurs or wrong work is discovered, be sure to report to the owner of the load. Take appropriate measures by following the instructions of the owner of the load.



- Do not lay down the unit.

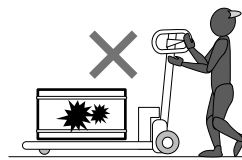

- Do not use a clamp lift.

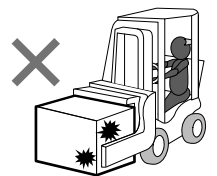

- Do not pull and drop the unit.

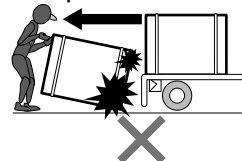

- Do not drop another load on the unit.

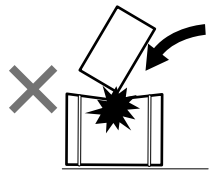

- When handling the unit with machinery, do not allow the machine to make contact with the unit.

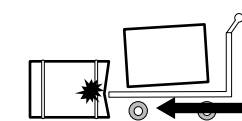

- Do not tip over the unit.

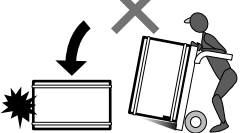

- Do not climb the unit.

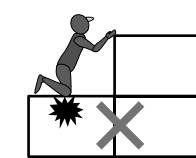

- Do not butt the knees against the unit. Do not carry the unit on the knees.



## 2. Mounting (Continued)

### Installing the tank unit

The weight of the tank filled up with water is approx. 530 kg. (400 L type)

Install the unit on a horizontal floor surface with a withstand load.

- Using a level, make sure that installation floor surface is horizontal.  
Occurrence of inclination due to the effect of the product weight may cause the unit to fall over.
- When installing the unit upstairs, consider the weight of the unit filled up with water, and implement an earthquake-resistance strength design of the building. Then install the unit according to the laws and standards of local governments. Take an appropriate fall prevention measure for the tank unit, and fix it.

#### NOTE:

After filling up the tank in “5. Commissioning”, make sure again that the tank unit is horizontal, using a level.

If it is not horizontal, be sure to remake the installation surface horizontal.

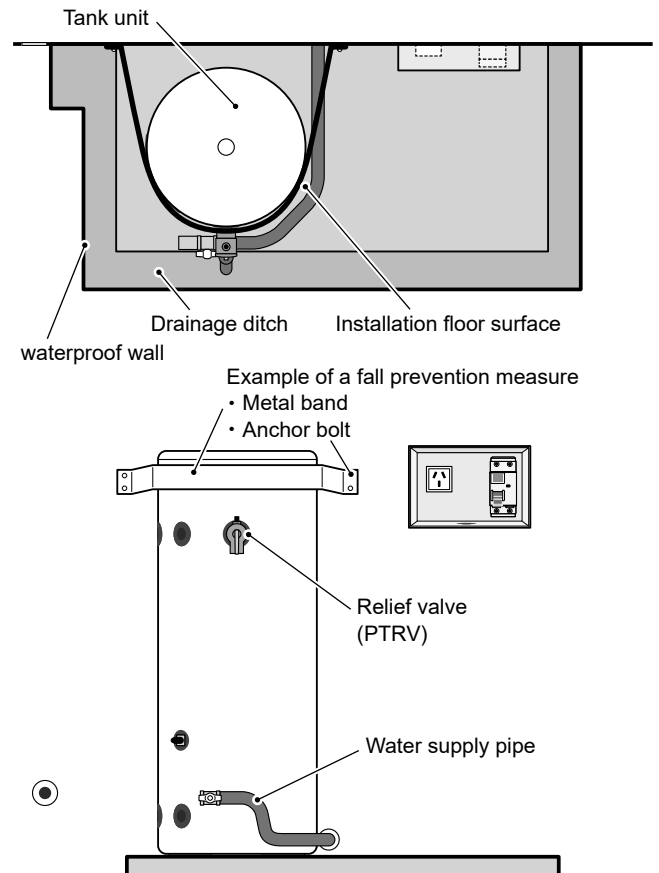

### Space for drainage path and piping maintenance (repair)

- After installation, perform construction work for the tank unit, considering the following points for maintenance.
  - Hot water or water in the tank unit may be discharged completely. Create a structure that does not allow the drained water to be spilled over from the tank water inlet port and strainer part.
  - While heating operation is in progress, expanded water is drained from the relief valve. Make sure that no problem is found in the drainage passage.
  - Ensure enough space, as shown in the figure on the right, for water supply and hot water piping work, installation of the main water supply tap and strainer, installation of CO<sub>2</sub>HPU piping, and maintenance of these pipes.
  - Secure space for replacing the anode rod. (figure at right)

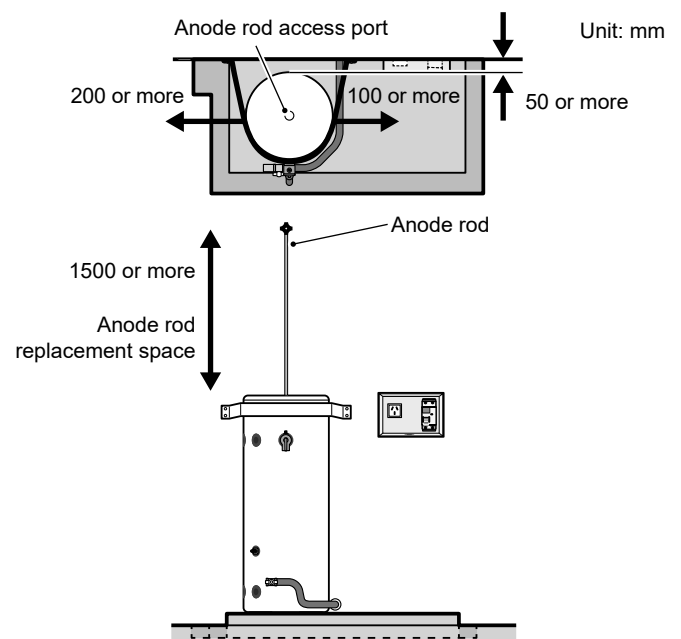

# Installing the CO<sub>2</sub> heat pump unit (CO<sub>2</sub>HPU)

## 1 Install a high-level base.

Install it on a horizontal floor surface.  
Select and install a base with a height of 0.1 m or more.  
Fix it with an anchor as necessary.

- Do not install the unit directly on the ground.  
(Drainage failure may occur, resulting in damage due to internal corrosion of the unit.)

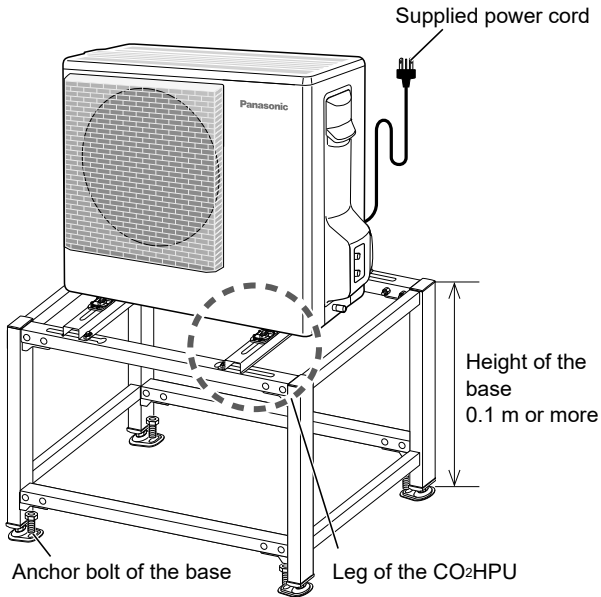

## 2 Fix the leg of the CO<sub>2</sub>HPU using a bolt and nut.

Refer to the installation manual of the high-level base during installation.

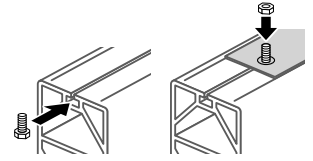

## 3 Using a level, make sure that the unit is installed horizontally.

### [Attention]

- Be careful not to damage the supplied power cord during work.
- Do not install the unit where a puddle forms in case of rain or snow, or snow drifting or falling of snow occurs. In a snow zone, install a snow prevention roof, etc. on the CO<sub>2</sub>HPU not to allow the fan part to be blocked by snow or ice.
- Do not install the unit where sewage gas flows backwards.
- When installing the unit in the following locations, adjust the height of the base so that water or corrosive substance does not penetrate into the inside the CO<sub>2</sub>HPU.
  - Location with lots of fallen leaves, a cloud of dust, or volcanic ash
  - Location where muddy water may flow in
  - Location where anti-freezing agent is sprayed
  - Location where pet food, hair, or urine may enter

## Space for maintaining performance and maintenance (repair)

- Open at least three directions among front, back, right, left, top, and bottom with respect to the air outlet side to secure ventilation passage. If two directions can only be opened, or the installation space is too narrow, frost or condensation water easily forms on the entire area of the aluminium fin of the CO<sub>2</sub>HPU, and the heating performance may be degraded.
- If there is any obstacle such as a wall in the surrounding area, follow the instructions in the figure below.

### ■ When there is no obstacle on the air outlet side

<Top view>

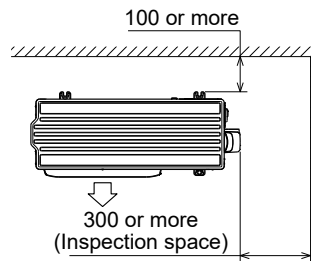
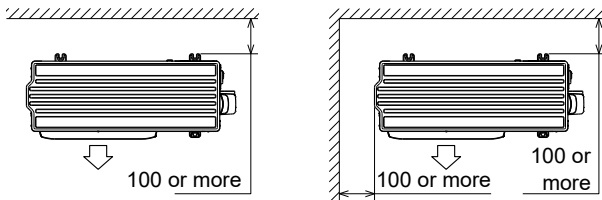

<Side view>

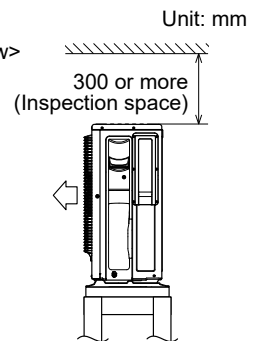

### ■ When there is no obstacle on the air outlet side

<Top view>

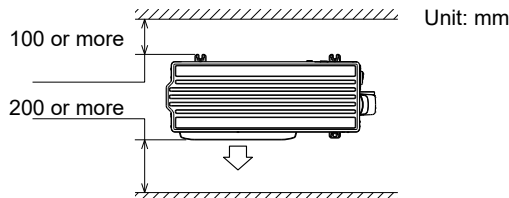

# 3. Plumbing

## Performing drainage work

Perform drainage work for the drainage pipe to be installed on the relief valve (PTRV) outlet of the tank unit, and drain hose to be installed on the drain port on the bottom plate of the CO<sub>2</sub>HPU.

If the pipe and hose are incorrectly installed, functional parts may be damaged. Exercise caution during construction work.

- 1** Install a bushing on the relief valve of the tank.
 

Attach a seal tape to the screw part of the nipple (R1/2-G1/2). Engage it straight with the screw part of the relief valve outlet, and tighten it manually until it stops.
- 2** Form the shape of the drainage pipe.
 

Form the shape of the pipe as shown in the figure at right.
- 3** Lay the pipe.
 

Engage the gasket (1/2) and drainage pipe straight with the screw part of the nipple (R1/2-G1/2), and tighten it manually until it stops.
- 4** Fix the end of the pipe.
 

Fix the end of the pipe using a band, etc.
- 5** Tighten the pipe.
 

Using two wrenches, tighten the relief valve and the union nut at the same time. For the tightening strength, check the value recommended by the packing manufacturer.

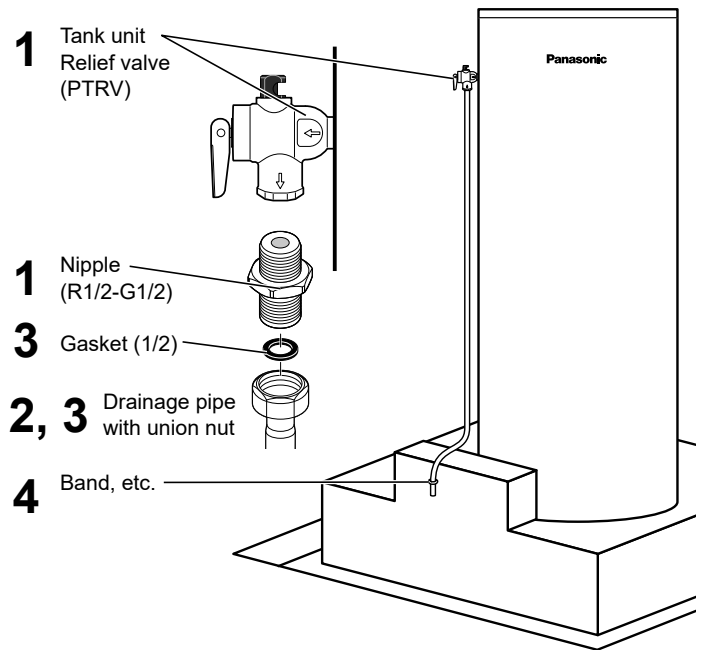
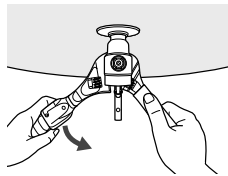

### [Attention]

● If water cannot be drained from the relief valve (PTRV) outlet, the unit may get damaged. Be careful not to cause the problems shown below.

- |   |   |  |   |
|---|---|--|---|
| <p> Do not lay the pipe horizontally. Do not allow the pipe to wave.</p> <p>Clogging may occur.</p> | <p> Do not allow the outlet to be submerged.</p> <p>Drained water may flow backwards.</p> | <p> Do not connect the pipe to another pipe.</p> <p>Drained water may flow backwards. Maintenance is impossible.</p> | <p> Do not place the pipe directly on the ground. Do not bury the pipe.</p> <p>Clogging may occur. Maintenance is impossible.</p> |
|---|---|--|---|

While the CO<sub>2</sub>HPU is operating, about up to 300 ml of drain water is generated per minute.

Observe the following steps to ensure the water is drained.

**1** Install a drain elbow on the bottom plate of the CO<sub>2</sub>HPU.

Insert the claw of the drain elbow into the drain port (Φ40 mm) on the bottom plate as shown at right.

\*: There is a gap between the bottom plate and the flange of the drain elbow. When water is not drained sufficiently, the water escapes from the gap to prevent the water from accumulating inside the unit. This prevents corrosion and damage to the unit.

**2** Connect a drain hose.

Set the drain hose (inner diameter Φ15 mm or Φ 16 mm) into the insertion port of the drain elbow.

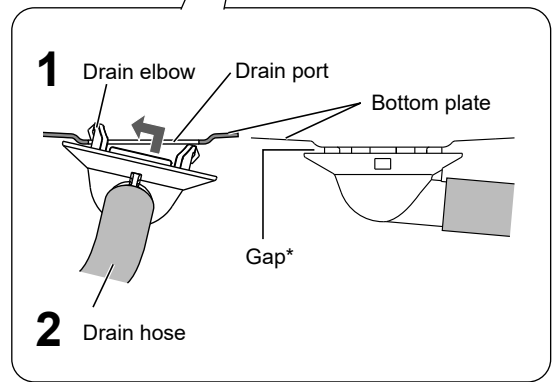
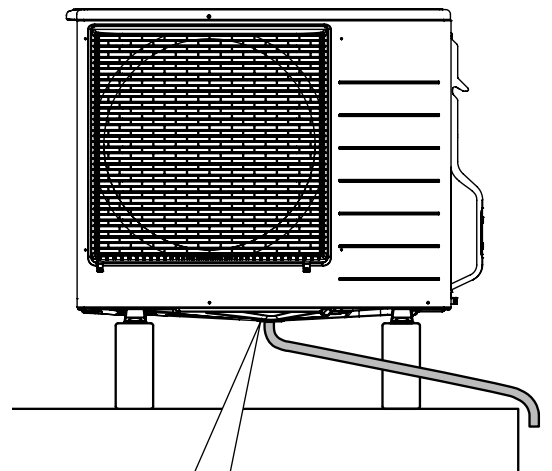





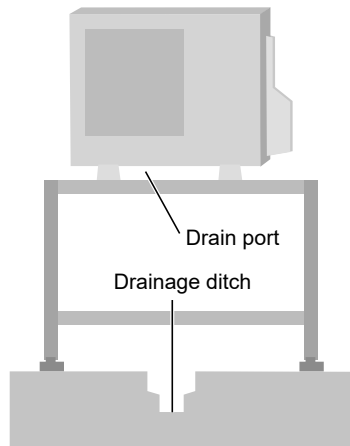

**NOTE:**

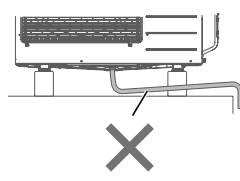
- In a freezing region, do not install the drain elbow since drainage of water may become impossible. Create a drainage ditch in the lower area to prevent drained water in the drain port from freezing and clogging.
- When humidity becomes high in winter, frost forms on the aluminium fin of the CO<sub>2</sub>HPU, and frost removal operation is automatically performed. At this time, a large amount of drain water is discharged. So perform drainage work not to cause any trouble in the surrounding area.

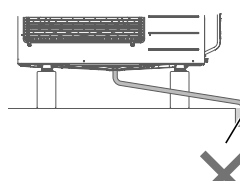

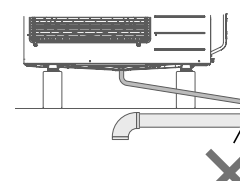
- If water cannot be drained, the unit may get damaged. Be careful not to cause the problems shown below.

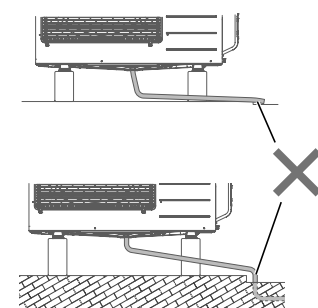
<p> Do not lay the pipe horizontally. Do not allow the pipe to wave.</p> <p>Clogging may occur due to freezing.</p> 	<p> Do not allow the outlet to be submerged.</p> <p>Drained water may flow backwards.</p> 	<p> Do not connect the pipe to another pipe.</p> <p>Drained water may flow backwards. Maintenance is impossible.</p> 	<p> Do not place the pipe directly on the ground. Do not bury the pipe.</p> <p>Clogging may occur. Maintenance is impossible.</p> 
---	--	--	--

# 3. Plumbing (Continued)

## Pre-assembling the piping members

Based on the regulations and other rules of each local government, a qualified piping construction operator shall perform piping construction work. According to the housing construction design of each household, prepare members necessary for the piping system as shown below.

For construction, use piping materials specified in national standards of AS/NZS2712:2007 and AS/NZS3498:2020 for functional parts and members.

(Parts indicated with  are included in the product.)

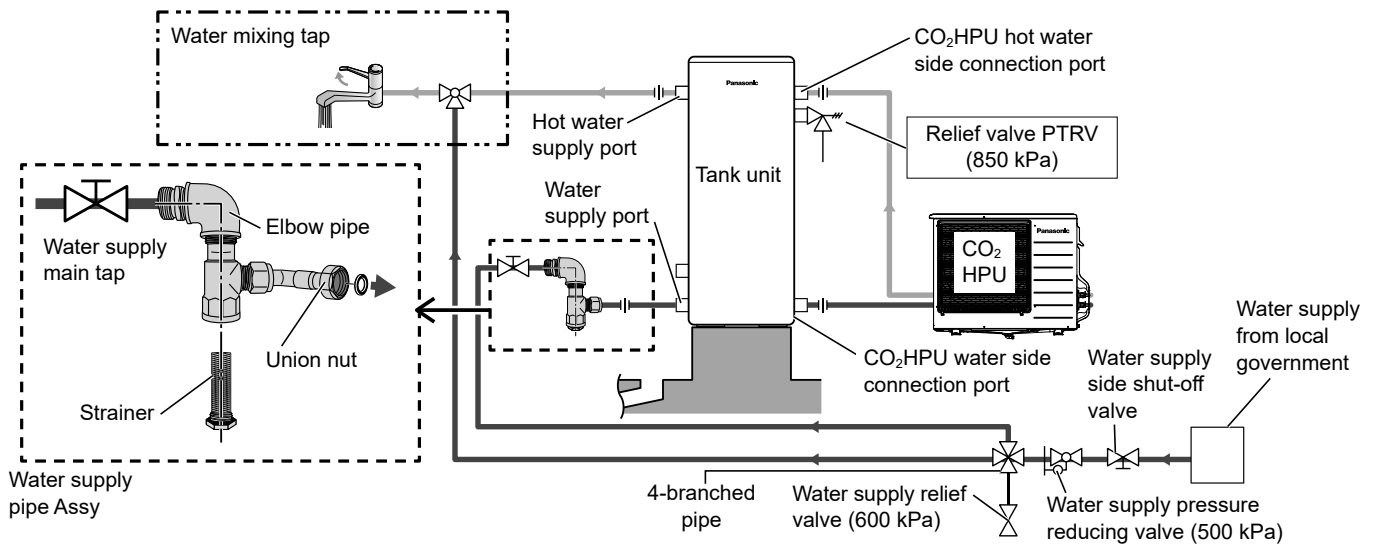

- Install a different diameter nipple (G3/4-1/2) on the pipe connection port of the tank unit. The same connection method is used for four locations of water supply port, hot water supply port, CO<sub>2</sub>HPU water side connection port, and CO<sub>2</sub>HPU hot water side connection port.

- 1** Set a flat packing (3/4) on the sealing surface at the innermost of the pipe connection port.  
Use one packing in the designated size for each location. Do not use a wrong size packing. Do not lay two packings. (Water leak may occur.)
- 2** Tighten the screw part of the different diameter nipple (G3/4-1/2) straight manually until it stops.
  - Tightening it at an angle may catch the screw part, resulting in water leak or damage to the tank unit.
- 3** Tighten the pipe screw with a torque of 15 to 25 N m using a torque wrench.
  - Tightening it with a strength exceeding the permissible range may cause water leak or damage to the tank unit.

- Do not connect to a solar water-heating system. The unit may malfunction due to the effect of high temperature water.

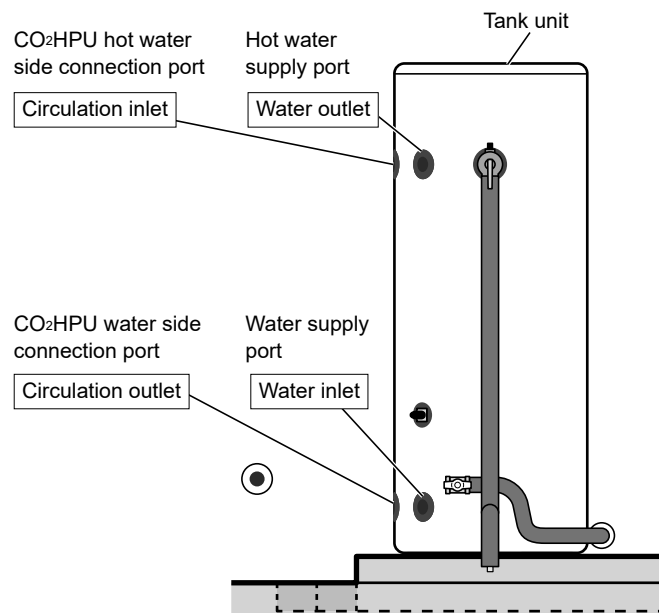
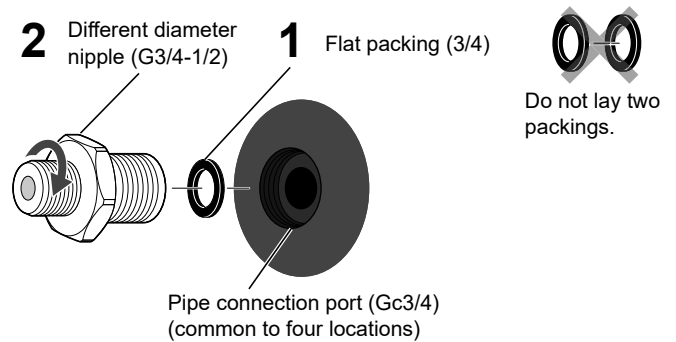

## Laying the water supply pipe

- A detachable strainer needs to be installed between the water supply main tap and water supply port for maintenance and periodical inspections of the hot water system. Complete the water supply piping members shown at right beforehand, and lay the pipe on the tank unit.

- 1 Complete the water supply piping members.
  - Lay the copper pipe (1/2) with a union nut (G1/2), and a strainer and elbow pipe in prescribed specifications. Then connect them to the water supply main tap.
  - Tighten the pipe screw as shown in the following figure.
- 2 Connect to the water supply port of the tank unit.
  - Set the flat packing (1/2) to the union nut (G1/2).
  - Install the strainer at the lower part as shown in the figure, and make sure that it can be removed and attached. (for cleaning the strainer and for draining the tank water.)
- 3 Tighten the pipe screw of the water supply port of the tank unit.
  - Tighten the pipe screw as shown in the following figure.

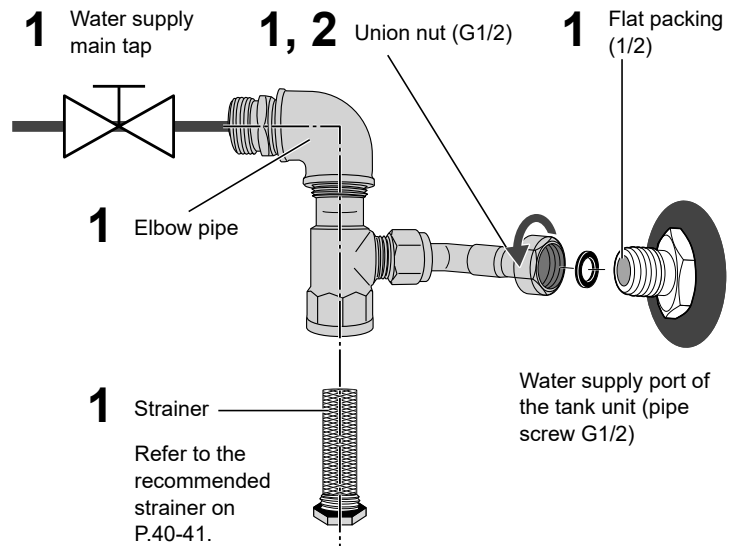

## Laying the hot water supply pipe

- 1 Connect the hot water supply pipe.
  - Connect the copper pipe (1/2) with a union nut (G1/2) to the hot water supply pipe.
  - Tighten the pipe screw as shown in the following figure.
- 2 Connect to the hot water supply port of the tank unit.
  - Set the flat packing (1/2) to the union nut (G1/2).
- 3 Tighten the pipe screw of the hot water supply port of the tank unit.
  - Tighten the pipe screw as shown in the following figure.

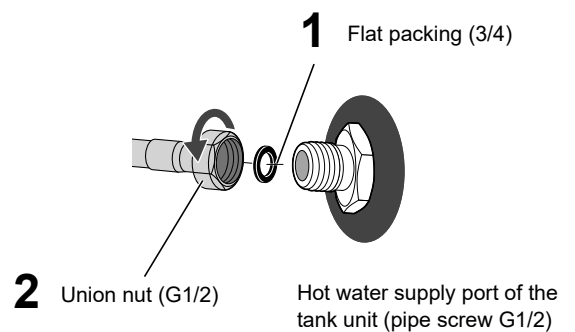

### [Tightening the pipe screw]

- Using two wrenches (piping tools) at the same time as shown in the figure, tighten the pipe screw within the tightening torque range of 15 to 25 N m. Note that if a recommended strength is specified by the manufacturer of piping seals (packing or seal ring) to be used, follow the instruction.

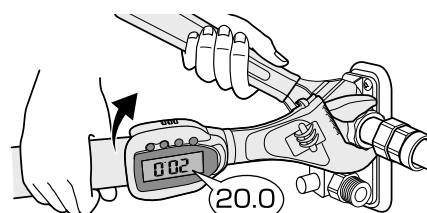

# 3. Plumbing (Continued)

## Laying the pipe of the CO<sub>2</sub>HPU

- The CO<sub>2</sub>HPU performs heating with highly efficient performance to make hot water. Observe the following constraint conditions to secure performance and durability. While considering the environment that uses hot water with corrosive nature containing chlorine ions, and the environment that uses very hot water for the hot water system, select members with a heat resisting temperature of 80°C or more, and lay the pipe using members that withstand long-term use. Use only members that have been confirmed by the piping member manufacturer that there is no problem with the specifications. (Water leak may occur.)
- When connecting the CO<sub>2</sub>HPU and tank unit, make sure that the water side and the hot water side are correctly connected as shown in the figure below. (A malfunction may occur.)

- Remove the pipe cover of the CO<sub>2</sub>HPU in the following steps to perform piping work. After the work is complete, attach the pipe cover.
- Do not use any pipes other than copper pipes certified for drinking water. Use a flexible stainless-steel pipe of 50 cm or less only when it is necessary to adjust the connection position. (Otherwise, problems such as CO<sub>2</sub>HPU malfunction, water leakage, or contamination of the hot water system with foreign matter or harmful substances may occur.)
- To prevent inclusion of foreign matter, cover the end of the pipe until connection is made.
- The restrictions for the pipe length and bend height of the pipe are shown in the following figure.

[Restriction of length]

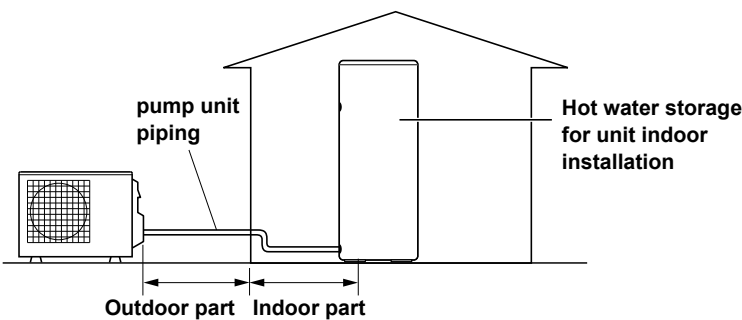

[Restriction of difference in bend height]

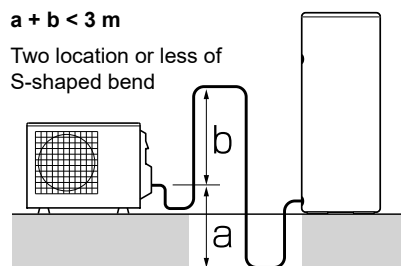

MATERIALS	PIPE LENGTH	PLACES USING AN ELBOW PIPE (ONE WAY)	THICKNESS OF THE INSULATION MATERIAL
Copper Pipes: Φ12.7	Standard: 5 m Maximum: up to 15 m	5 places or less	15 mm

- How to remove: Loosen the screw completely, and slide down the cover for removal.

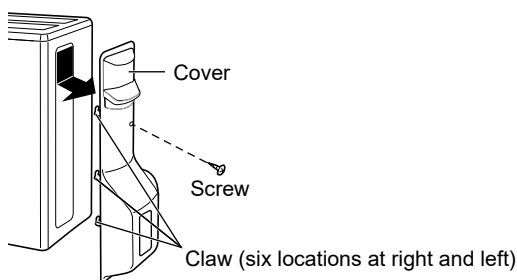

- How to attach: Slide the cover upward to attach it, and secure the cover with one screw.

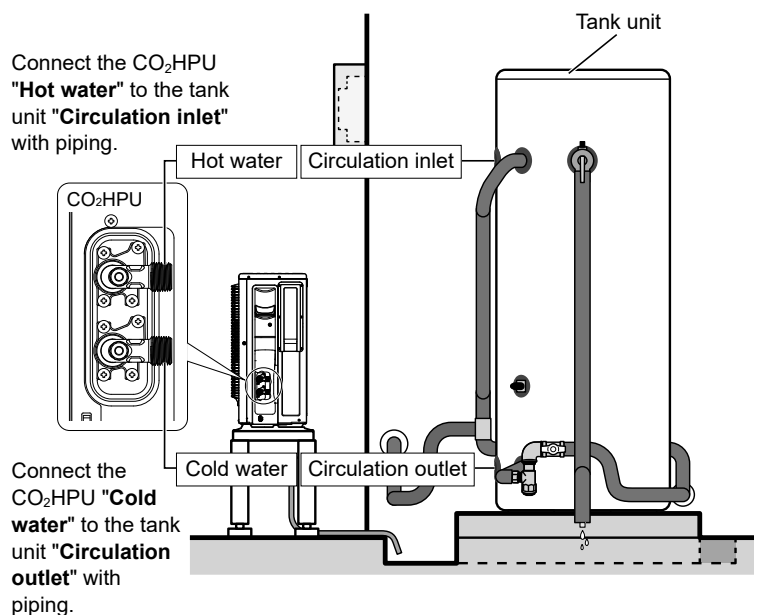
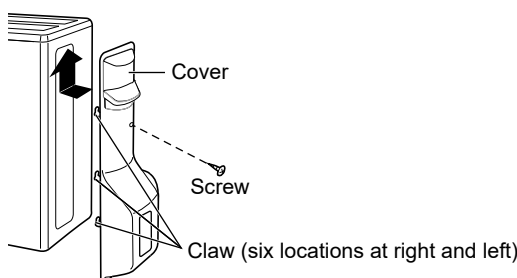

- Piping work is common to the CO<sub>2</sub>HPU and the tank unit.

- 1** Set the gasket to the pipe.
- Piping work is common to the CO<sub>2</sub>HPU and the tank unit. The illustrations show the piping work for the CO<sub>2</sub>HPU.

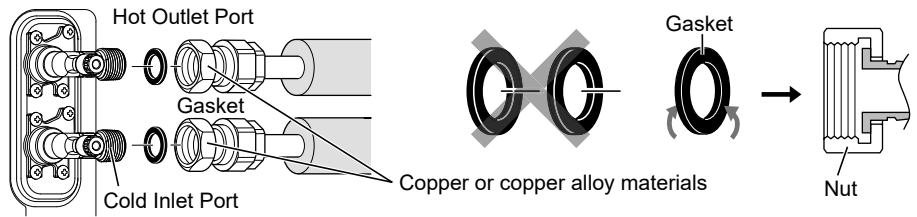

- 2** Tighten the screw part straight manually until it stops.
- Slightly pull the pipe, and check that the flange end of the pipe is attached firmly to the nut, and there is no wobbling. (Damage to screw, or water leak may occur.)

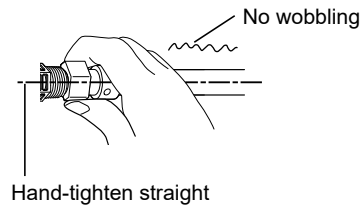

- 3** Tighten the pipe screw with a torque of 15 to 25 N m using a torque wrench.
- Tighten the pipe screw as shown in the figure.

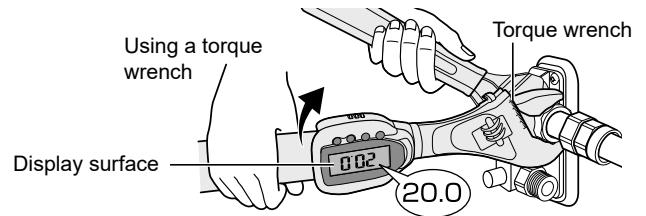

- 4** Perform thermal insulation treatment after water leak inspection.
- Attach a thermal insulation material on the connection part not to allow it to be exposed. This prevents heat loss and freezing.
  - Use a weather-resistant heat insulation material.

## Performing warm-keeping construction work

- Wrap all pipes in thermal insulation materials with a thickness of 15 mm. Since the roots of pipe connection parts of the tank unit and the CO<sub>2</sub>HPU in particular are likely to dissipate heat, ensure that the warm-keeping construction work is performed.

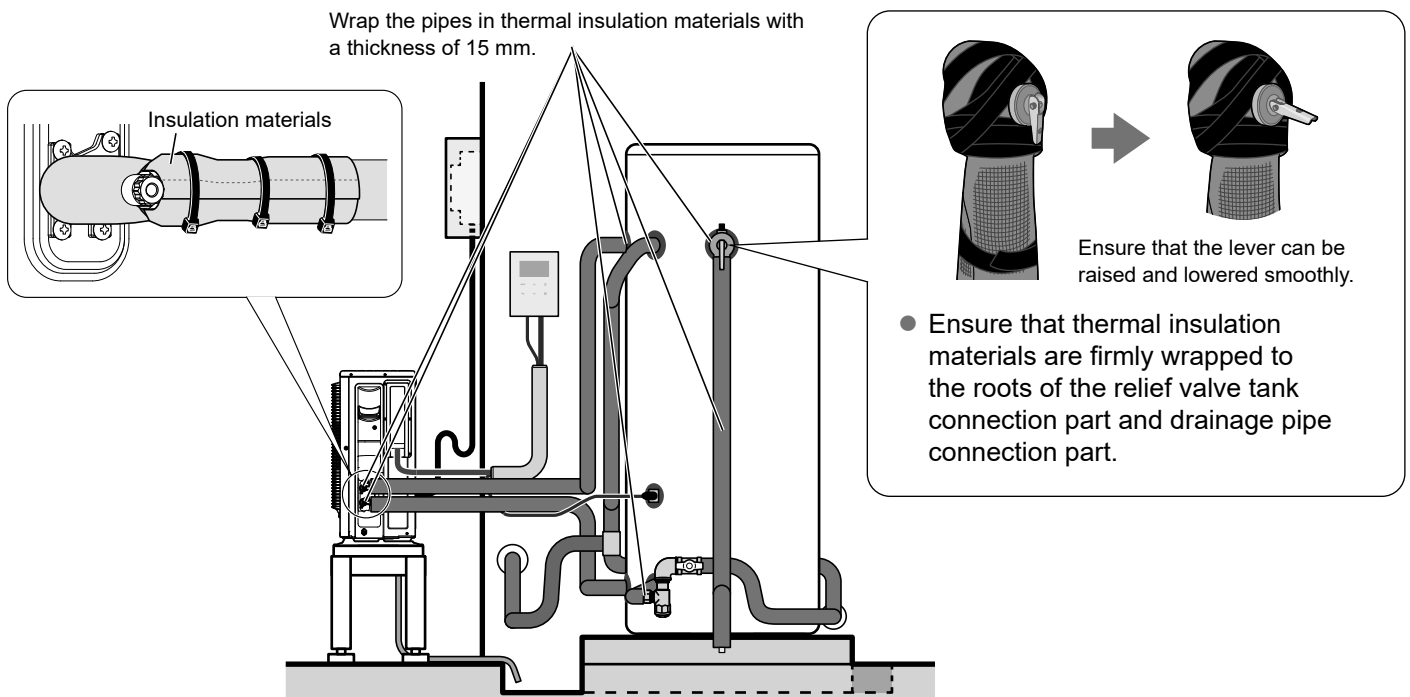

# 4. Wiring

## Installing the controller

### Precautions on construction

Observe the following constraint conditions for the installation location of the controller.

- Select a location where the display and switches are easy to see and operate.
- Do not install it on a metal wall since it incorporates a wireless communication device. (A communication failure may occur.)
- Do not install it near devices that emit radio waves, such as a microwave oven. Secure space of 0.2 m or more on top, bottom, right, and left of the controller. (A malfunction may occur.)
- Do not install it at a location that may become hot, such as a location near a stove or other combustion apparatuses.
- Do not install it at a location exposed to direct sunlight. (A malfunction may occur.)

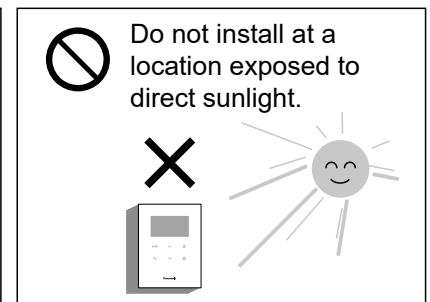
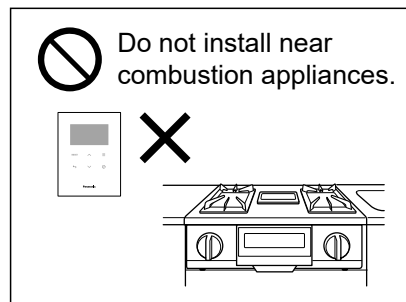
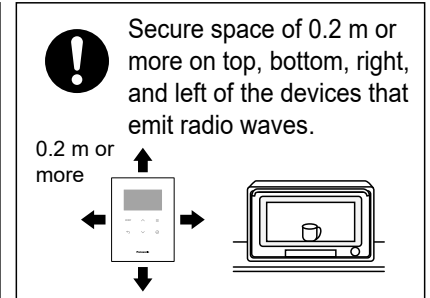
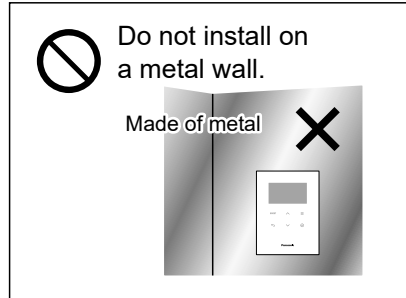

- The controller cable (5-core wire: 1.3 m) and tank sensor lead wire (2.8 m) have been incorporated in the product. Install the controller within a range where these cables can be connected correctly and safely.

### <Precautions during wiring work>

- Wire the controller cable and tank sensor with margins to prevent an external force from being applied during the installation work and at the completion of the wiring work. (A malfunction may occur.)
- When burying the wires in the wall or under the floor, use a sheath pipe or the like to protect the cable and lead wire from damage and make it easy to replace parts.
- Do not bundle them together with the power cable of the heat pump unit. Keep a distance of 50 mm or more for wiring.
- Do not conduct the installation work at an environment where water or mud spatters.

### Supplied accessories <Be sure to use the supplied accessories.>

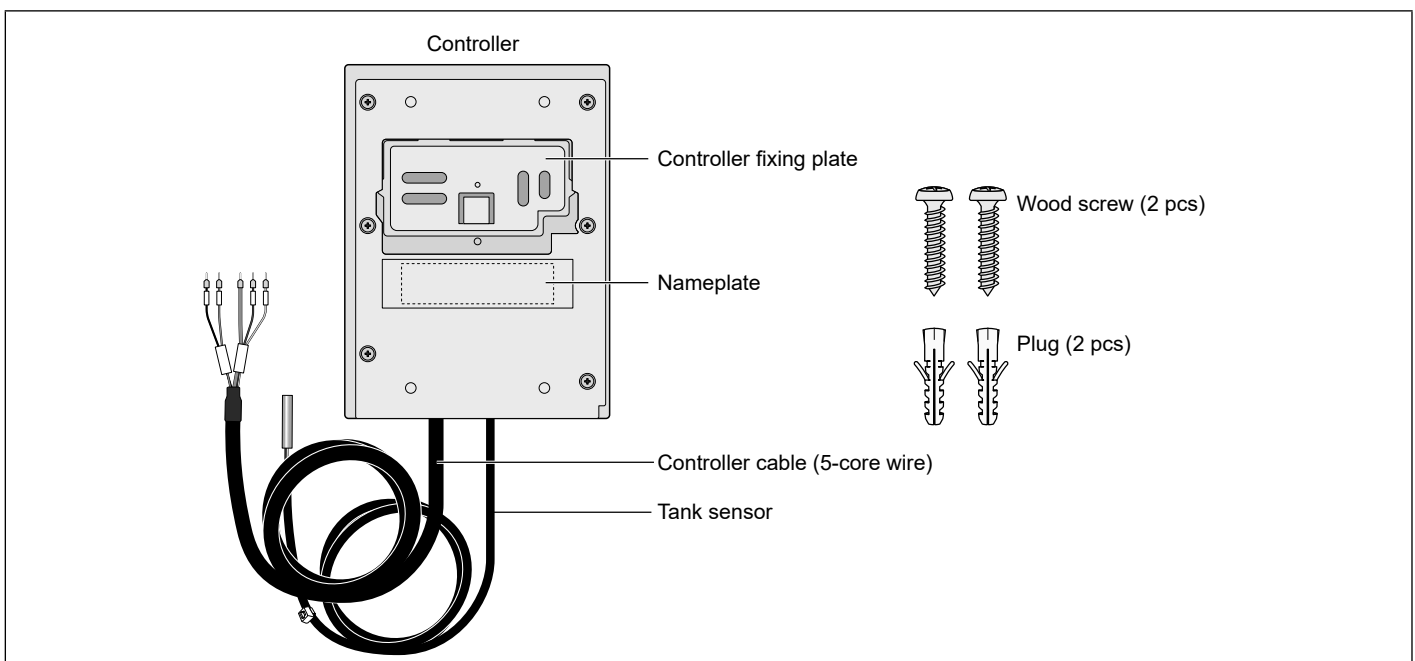

## Installing the controller

### 1 Remove the controller fixing plate.

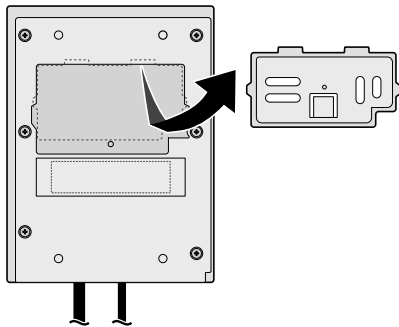

### 2 Mark the screw hole positions on the wall by referring to the figure below.

- Allow 5 mm of clearance above the controller for removal and attachment.

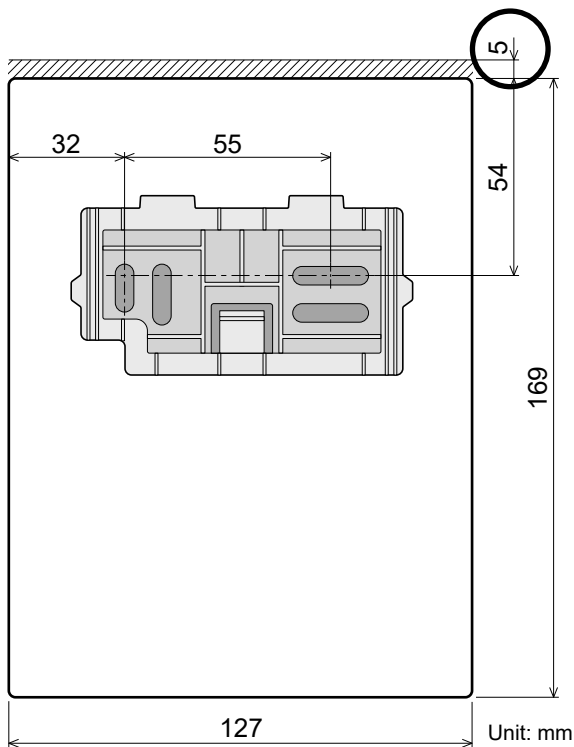

### 3 Drill a pilot hole as necessary.

Drill a pilot hole.  
(hole diameter  $\phi$  6 mm,  
depth approx. 30 mm)

Hammer the  
plug.

Use a wood  
screw for  
installation.

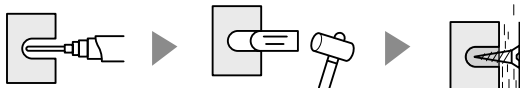

- When drilling a hole for a mounting screw on the wall of a building, be careful not to make the hole too large, considering the wall material.  
(A malfunction may occur due to dropping of the unit.)

### 4 Fix the fixing plate with wood screws.

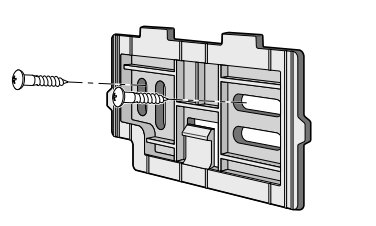

### 5 Attach the controller on the controller fixing plate.

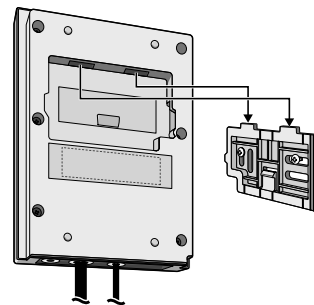

- Operate the controller's switches to ensure that there is no looseness or rattling in the case or surrounding parts.

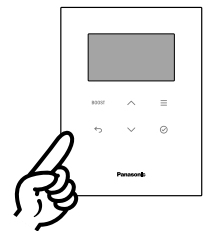

### NOTE:

- The name plate on the back of the controller includes important information. Perform construction work, ensuring that the name plate can be checked when the controller is removed even after installation.

### 6 Wire the controller cable and tank sensor.

- When inserting a sheath pipe for the cable, be careful not to allow it to make contact with the metal plate of the exterior of the main unit during wiring.
- Be careful when handling the cable end and tank sensor since they easily deform.

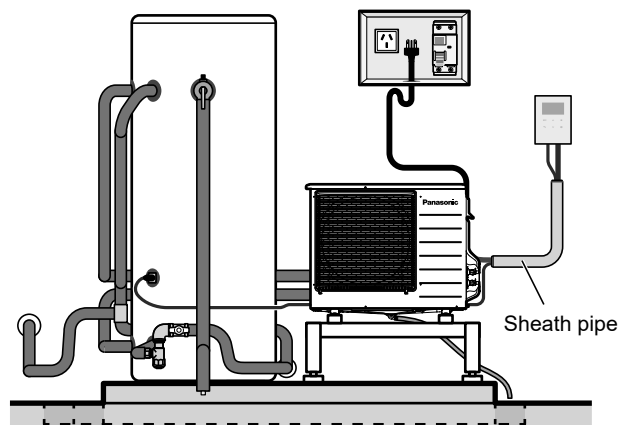

# 4. Wiring (Continued)

## Connecting the controller to the CO<sub>2</sub> heat pump unit

- 1** Remove the cover of the heat pump unit.
- Loosen the mounting screws (6) on the cover and remove it.

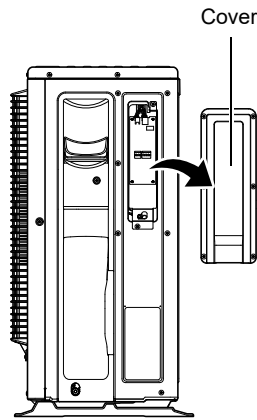

- 3** Secure the controller cable
- Loosen the screws, remove the fastener, pass the cable through it, and reattach it as shown in the figure.
  - Ensure the cable does not sag or touch the edge of the metal plate.

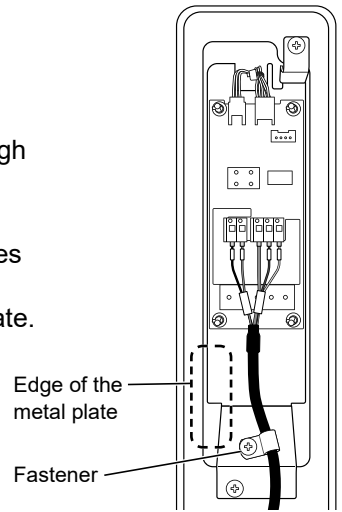

- 2** Connect the five controller cables to the specified terminal block as shown below.

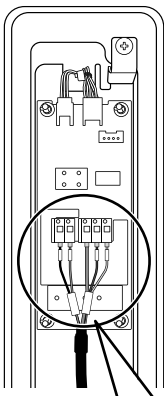

- 4** Attach the cover and secure it with the screws (6).

- Set the controller cable so that it passes through the center of the cover opening.

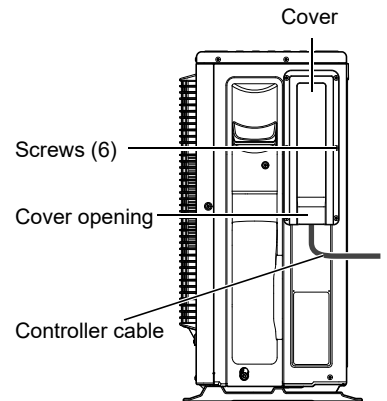

- 1** Insert each controller cable according to the color printed on the terminal block. (4-code and GRN (SG))

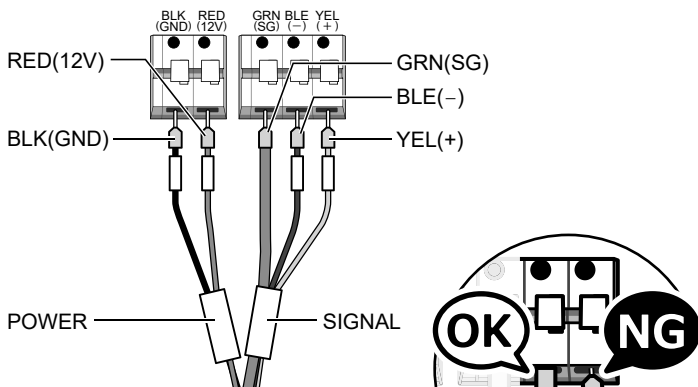

- 2** Insert the controller cable end to the innermost of the terminal hole firmly.

When removing the cable...

Press and hold the white button above the connector while removing the cable.

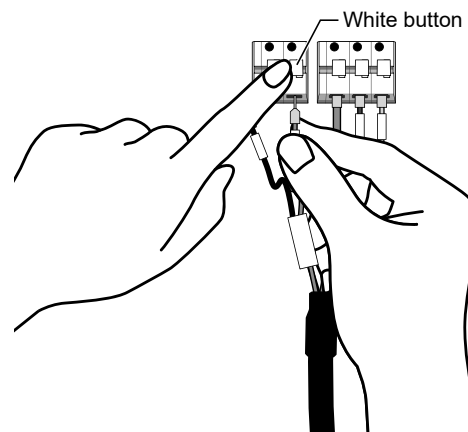

# Installing the tank sensor

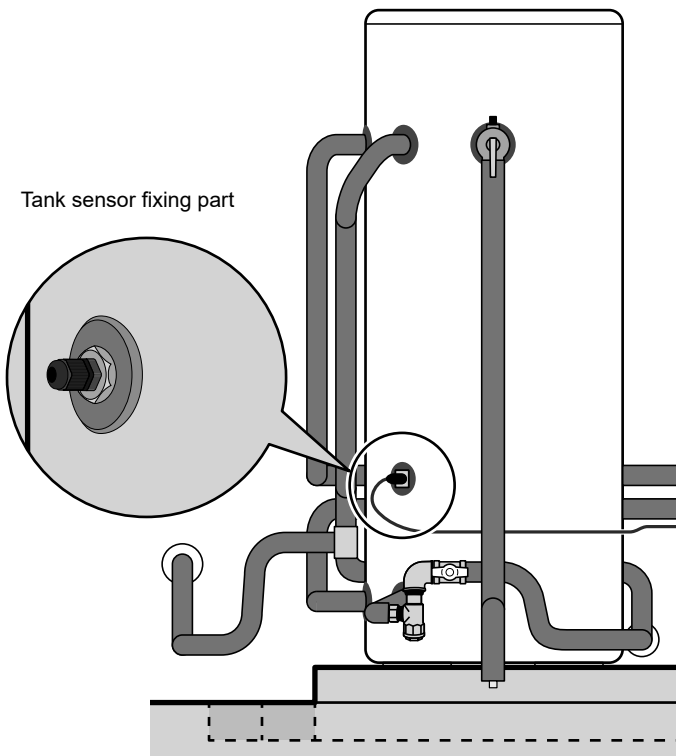

**1** Loosen the resin nut of the tank sensor fixing part, and insert the tank sensor.

- Insert it until the tip of the sensor reaches the innermost.

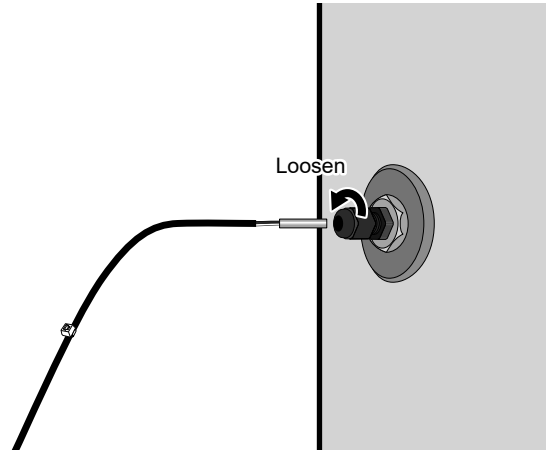

**2** While the tank sensor is butted against the innermost, tighten the resin nut, and fix the sensor so it does not come off.

When the tip of the sensor reaches the innermost, the band comes at this position (approximate position).

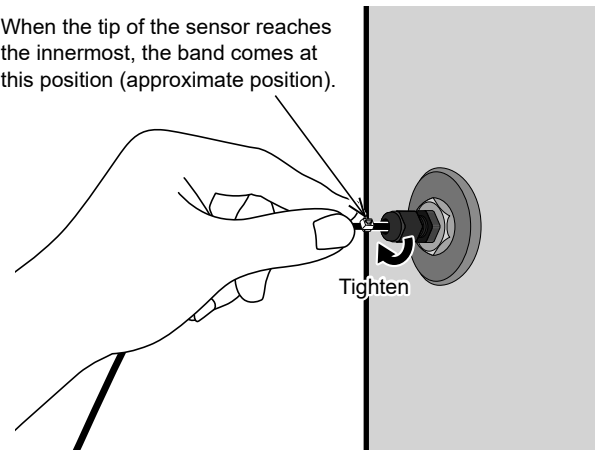

- Tightening the resin nut should be done without using tools, as there is a risk of damage. After tightening, please ensure that the cable does not move when lightly pulled.

# 5. Commissioning

## Filling up the tank

### Filling up the tank, and checking leakage

- Operate the piping members according to the following steps.

- 1 Operate the relief valve (PTRV) lever of the tank to open it.

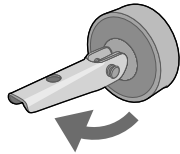

- 2 Open the water supply main tap.

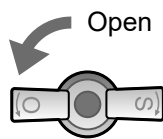

- 3 Confirm that water comes out from the outlet port of the relief valve (PTRV)
  - The tank is full of water if the water comes out successively. Up to approx. 40 minutes are taken.

- 4 Lower the relief valve (PTRV) lever of the tank to close it.

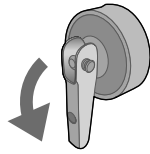

- 5 Open the tap on the hot water side of the household water mixing tap. When water containing air stops coming out and water begins to come out successively, close the water mixing tap.

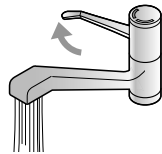

- 6 Make sure that there is no water leakage from all pipes.
  - After confirming that there is no leakage, cover the pipe completely with thermal insulation material up to the base.
  - Be sure to tell the customer the mounting position of the water supply main tap and the operation method.

#### NOTE:

- Using a level, make sure that the tank unit is horizontally installed. When the tank unit is inclined due to the effect of full water weight, correct it immediately.

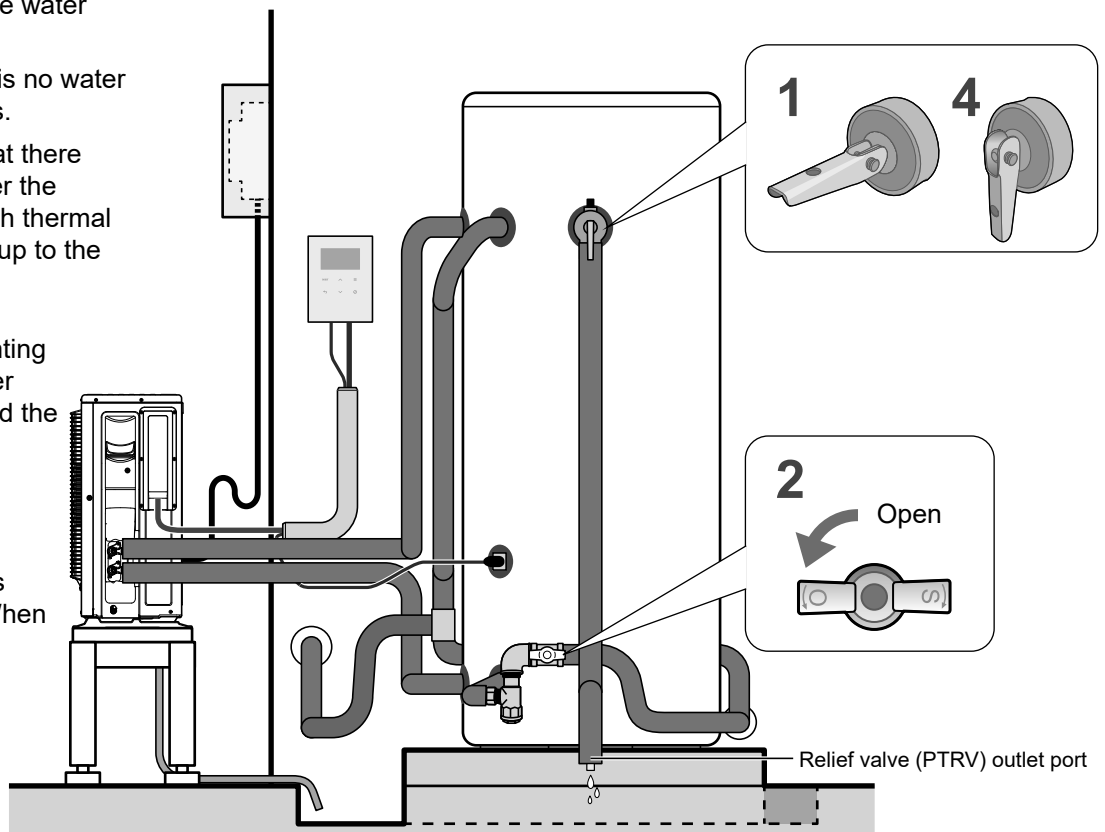

### Discharging the air from the CO<sub>2</sub>HPU

- Make sure that the following step has been completed. If the step is not completed correctly, the heat pump unit may malfunction.

- 7 Open the drain plugs (three locations). (Do not remove the drain plugs not to lose them.) Run water for at least one minute. Make sure that water containing air stops coming out and water begins to come out successively. Then close all drain plugs.

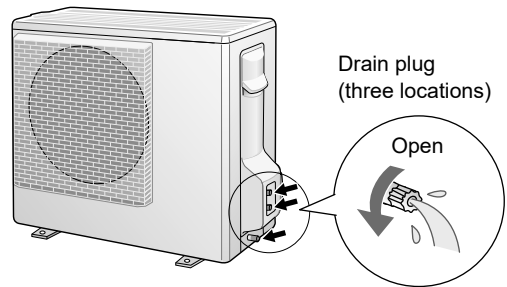

## Cleaning the tank to confirm no problems

A problem may occur at the beginning of use due to fragments or dirt of members entering inside the pipe during plumbing work.

Follow the instructions of "Cleaning the tank" in this operation manual for cleaning.

- ① Drain water to wash out sediments deposited at the bottom of the tank.
- ② Wash the strainer (filter) of the tank with water.
- ③ Operate the relief valve lever up and down, and make sure that there is no dirt attach on the valve and no leakage.

Refer to  
P.28

## Checking the capacity of the power facility for conformity

- ① Make sure that the earth leakage breaker, power line, and socket are wired exclusively to this hot water system. (An electric leakage or fire may occur.)
- ② Make sure that the capacities of all electric equipment are appropriate. Make sure that electric equipment satisfies the standards with respect to the CO<sub>2</sub>HPU specifications (rated voltage, maximum current value).
- ③ Read the user manual of the earth leakage breaker carefully, and make sure that the earth leakage breaker is normal.

Refer to  
P.64

## Turning on the power

- ① Insert the power plug of the CO<sub>2</sub>HPU to the prescribed socket.
- ② Turn [ON] the earth leakage breaker.
- ③ Confirm that the controller lights up.

Refer to  
P.16

## Checking the controller

- ① Make sure that the controller can be removed from the fixing plate and the description on the name plate on the back can be read.
- ② Be sure to remove the protective transparent film on the surface of the controller. If the film remains attached, the controller may malfunction due to the effect of sunlight, etc.
- ③ When the controller surface is dirty, wipe off the dirt carefully not to damage the surface.
- ④ When the shading contrast of the LED display needs correction, adjust the controller settings according to the steps described on the "Maintenance" page.

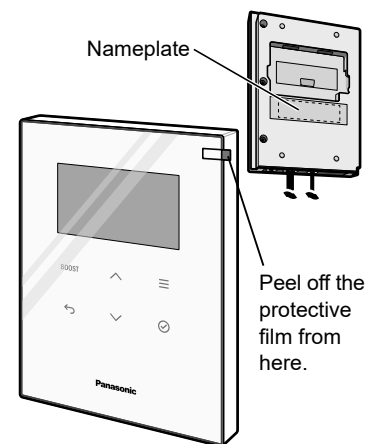

Refer to  
P.55

Refer to  
P.27

## Setting the date and time

- ① Set the current time correctly.
  - Note in particular that if the time is deviated, water cannot be heated, or an unexpected electric fee may be charged.

Refer to  
P.17

# 5. Commissioning (Continued)

## Performing a test run for heating

Heating operation is not performed when the power is turned on for the first time after the CO<sub>2</sub> heat pump hot water system is installed.

Therefore, be sure to perform a test run for heating to make sure there is no abnormality.

**1** With the main screen displayed, press and hold [BOOST] for five seconds.

- The [BOOST] function works only on the main screen of the controller. During [BOOST], the entire volume in the tank is heated to 63°C.

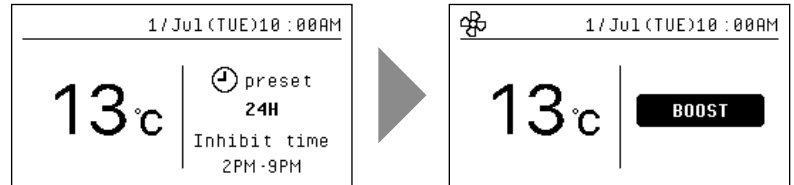

**2** Check the operation state of the CO<sub>2</sub>HPU and tank unit.

- Is there any abnormal sound from the CO<sub>2</sub>HPU or high-level base, or is there any annoying reflected sound from a remote location?
- Have the following construction work been performed correctly according to “Performing drainage work” on P.48 - 49 in this manual? Is there any water leakage?
  - Drainage of the CO<sub>2</sub>HPU
  - Relief valve and drainage pipe of the tank unit
- Are there any other failures such as water leakage from connection parts?

Check that there is no abnormal operation sound from the CO<sub>2</sub>HPU.

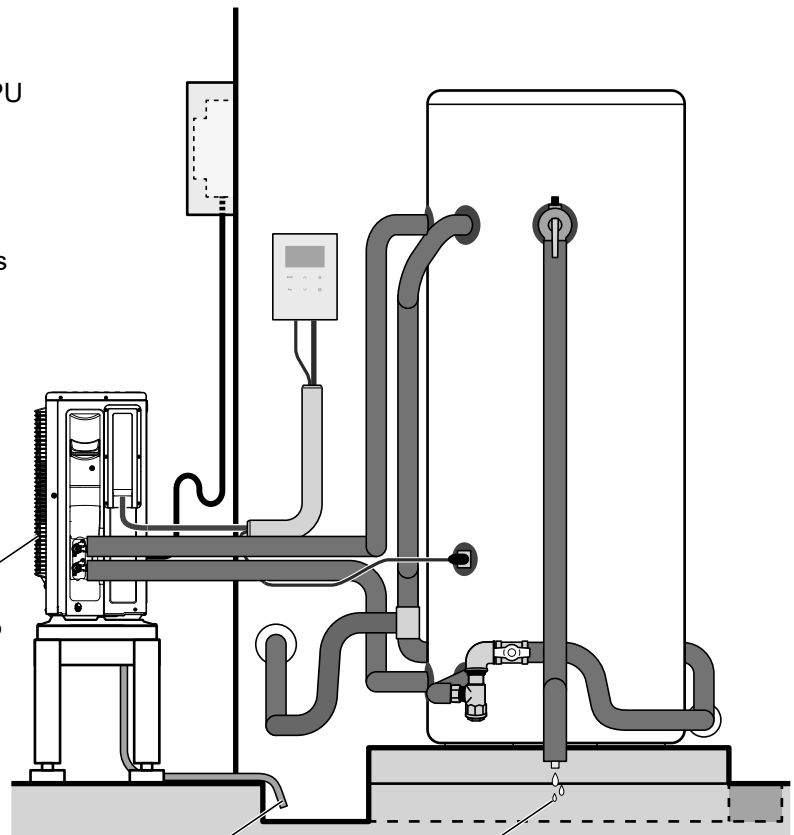

Check that there is no failure such as water leakage from the drainage part of the CO<sub>2</sub>HPU.

Check that there is no failure such as water leakage from the drainage pipe of the tank unit relief valve.

# Adding an Option

## Linking up with solar power generation

When a solar power generation system is installed at home, heating operation can be performed by utilizing electricity of solar power generation.

The heating operation is performed by connecting the PV-DRY output cable of the solar power generation system to the controller, and changing the setting of the controller to detect the supply of electricity from the solar power generation.

- Read the operation manual of the solar power generation system carefully, and prepare and wire the PV-DRY output cable.

### 1 Process the PV-DRY cable terminal.

- Use a correct tool for processing as shown below. (A malfunction may occur.)

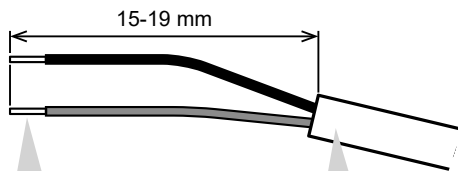

Form the PV-DRY cable end into a shape of  $\Phi 1 \text{ mm} \times 5 \text{ mm}$  (do not solder).

PV-DRY cable Recommended spec; Heat resistant round hammered PVC wire  $\Phi 4 \text{ mm}$

### 2 Turn [OFF] the power of the CO<sub>2</sub>HPU.

- Turn [OFF] the earth leakage breaker, and remove the power cord plug from the socket. (An electric shock or malfunction may occur.)

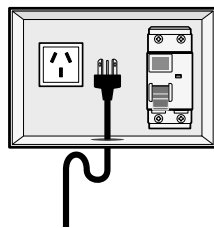

### 3 Loosen the screws (6 pcs) on the rear of the controller, and remove the case.

- Do not use an electric screwdriver for assembly and disassembly of the controller. (A malfunction may occur.)

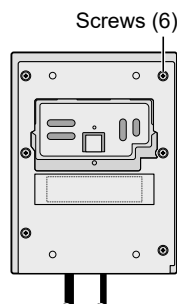

### 4 Penetrate the hole for the PV-DRY cable connection on the controller case

- Use a (+) screwdriver and drill the hole by gently pressing and turning at the indicated position in the figure.
- Handle with care, as all electronic components are easily damaged. (May cause malfunction)

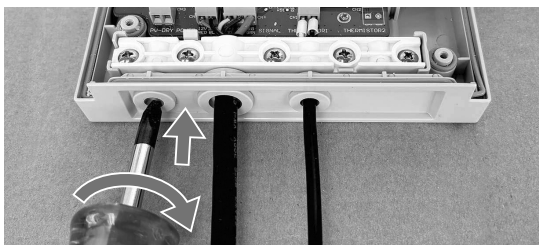

### 5 Loosen the five screws on the cable clamp, then release the two clips shown in the figure by pulling them outward to remove the cable clamp.

- Be careful not to damage the cables and screw parts during work.

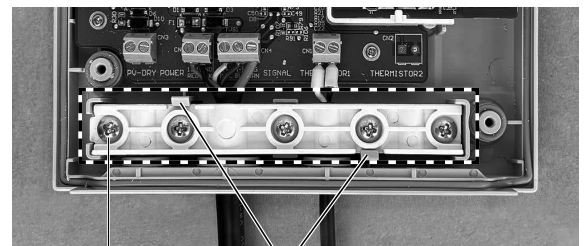

Screws (5) Two clips

### 6 Insert the PV-DRY cable through the PV-DRY cable port on the controller, and fully insert the cable end into the terminal block to make the connection.

- Use a flathead (-) micro screwdriver to tighten them to the terminal blocks (2).

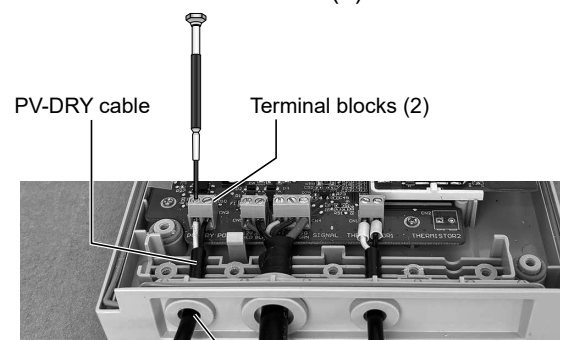

PV-DRY cable Terminal blocks (2)

Cable port

### 7 Set cable pressers on the wiring part, and tighten them with screws (5 pcs).

- Be careful not to damage the cables and screw parts during work.

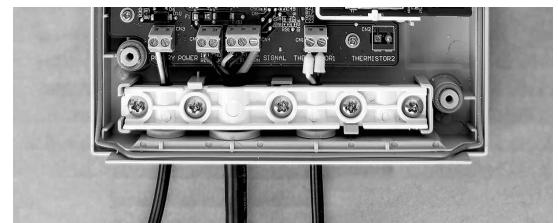

### 8 Attach the case.

- Set the seal packing and O-rings (6 pcs) around the outer circumference of the case at the specified positions. Be careful not to damage them during work. (A malfunction may occur.)

# Construction Check List

	Page	Check
<b>Installation</b>		
Is sufficient space secured for the CO <sub>2</sub> heat pump unit to maintain performance and for maintenance (repair)?	P.47	
Is the tank unit installed on a flat location that withstands the weight of the tank filled up with water?	P.46, P.58	
When draining the tank, is there any issue in the surrounding area? If a recommended strainer is installed, is it possible to drain the tank by removing the filter, allowing the water to flow smoothly to the drain?	P.40-41	
Is sufficient space secured for the tank unit for maintenance (repair)?	P.46	
Is it ensured that there is no gas containers or inflammable materials?	P.3	
Is each of the CO <sub>2</sub> heat pump unit, controller, and tank unit with model numbers described in this manual connected? Are all connections compliant with descriptions in this manual?	P.64-67	
<b>Piping construction</b>		
Is water supply compliant with the standards of water for drinking in local governments?	P.42	
Was an appropriate measure taken to prevent foreign substances from entering the inside the pipes before piping construction work?	P.52	
Is the drainage pipe for the relief valve outlet of the tank unit installed, complying with the descriptions in this installation manual?	P.48	
Is the drain hose of the CO <sub>2</sub> heat pump unit installed, complying with the descriptions in this installation manual?	P.49	
Is the dedicated water supply main tap and strainer mounted on the tank unit for maintenance (repair)?	P.51	
Are the materials of the piping members and the installation method compliant with the descriptions in this installation manual?	P.40-41	
Are the pipe connections on the hot water side and water side of the CO <sub>2</sub> heat pump unit and tank unit compliant with the descriptions in this installation manual?	P.52-53	
Is the warm-keeping construction for pipes and connection parts of the CO <sub>2</sub> heat pump unit and tank unit compliant with the descriptions in this installation manual?	P.53	

	Page	Check
<b>Wiring</b>		
Is the electrical capacity of all wiring devices sufficient in relation to the maximum current value of the CO <sub>2</sub> HPU?	P.40-41	
Is there a dedicated earth leakage breaker installed? Is there an earth leakage circuit breaker with a capacity of 20 A installed?	P.40-41	
<b>Inspection</b>		
Was no problem found as a result of water leak inspection of the tank unit and CO <sub>2</sub> heat pump unit conducted with water supplied and filled up?	P.58	
Was the air discharged from the inside the CO <sub>2</sub> heat pump unit?	P.58	
Was no problem found in heating operation of the tank unit and CO <sub>2</sub> heat pump unit after BOOST heating was performed in the test operation?	P.60	
Was water supply strainer connected to the tank unit cleaned?	P.28	
Was no problem found in the inspection of the earth leakage breaker for power source of the CO <sub>2</sub> heat pump unit?	P.59	
Is there any abnormal sound from the CO <sub>2</sub> heat pump unit or high-level base, or is there any annoying reflected sound from a remote location?	P.60	
Is the drained water from the CO <sub>2</sub> heat pump unit led to the drainage ditch normally?	P.49, P.60	
Is the date and time indication on the controller correct? If the time is shifted, the electric fee of the customer may become high.	P.17	
Is the controller securely installed and fixed on the wall?	P.55	
Was the screen display of the controller checked? Was the screen contrast adjusted?	P.27	
Is an impulsive sound heard when the hot water or water is stopped? Is there any vibration? Is there no abnormality with the water supply pressure?	P.36	
Was the flow rate of shower checked with the customer? Was the water supply pressure and strainer checked to see no problem according to the customer's intent?	—	

# Specifications

CO <sub>2</sub> HPU		HE-UM60CR	HE-UM40CR
Dimensional drawings			
Power supply		230 V-240 V (single-phase) ~ 50 Hz	
Current input (Max)		10.0 A	
AS 5125 Test condition 4 (*)	Heat output	5.06 kW	4.00 kW
	Electric input	0.83 kW	0.80 kW
	C.O.P.	6.11	5.00
	Noise level	37 dB(A)	37 dB(A)
Heating temperature		63 °C	
Power input (Max)		2.3 kW	2.0 kW
Heat output (Max)		6.5 kW	5.6 kW
Heat pump location		Outdoor	
Allowable installation outdoor temperature		-10 °C (Minimum)	
Ingress protection rating		IPX 4	
Power cord type		3-Pole (L, N, EARTH) : Connected to the power terminal block of CO <sub>2</sub> HPU	
Type of power plug		Type I	
Power circuit fuse		CO <sub>2</sub> HPU : 250 V 30 A	
Refrigerant		R744 (CO <sub>2</sub> )	
Charging amount		900 g	630 g
Design pressure: high/low		14 MPa / 9 MPa	
CO <sub>2</sub> HPU weight		46 kg	41 kg
Exterior color		Ivory white	
Water connection port (water side/hot water side)		G1/2 B	
Drain port		Drain elbow	
Applicable Hose Inner Diameter		Φ15 mm - Φ16 mm	

(\*) AS 5125 Test condition 4: DB32.5 °C / WB26.3 °C / Inlet Water 21.0 °C

Controller

HE-1MAHR

Dimensional drawings

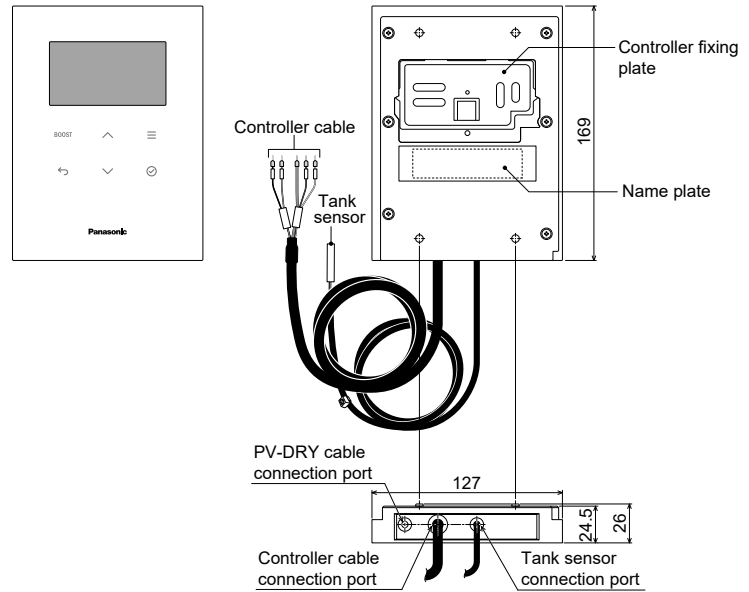

Power source	DC12.2 V
Rated power consumption	4 W
Wireless LAN	Module incorporated (See P.70 for details.)
Ingress protection rating	IPX 4
Controller cable	4-core (See P.56 for details.)
Terminal	Ferrule E 0508
Effective length	1.3 m
Tank sensor	Φ5 mm × 24 mm
Sensor cable	2-core
Effective length	2.8 m

# Specifications (Continued)

## Glass Lined Tank Unit

### Dimensional drawings

HE-TM400AHR

HE-TM315AHR

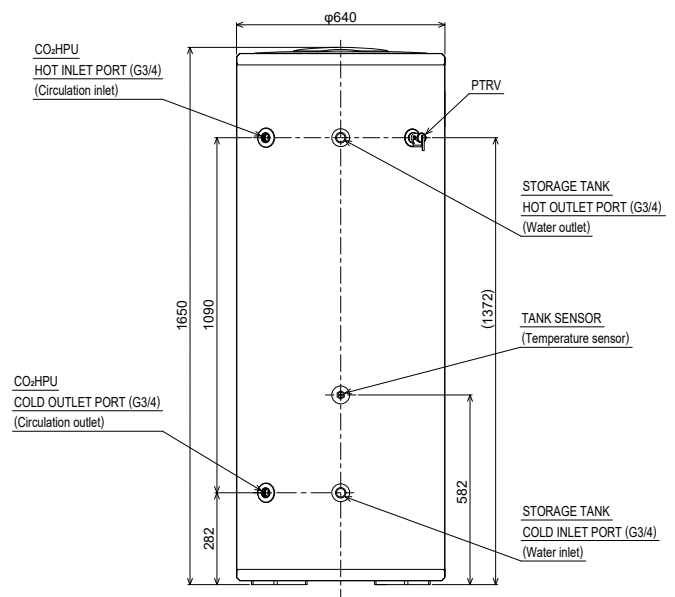
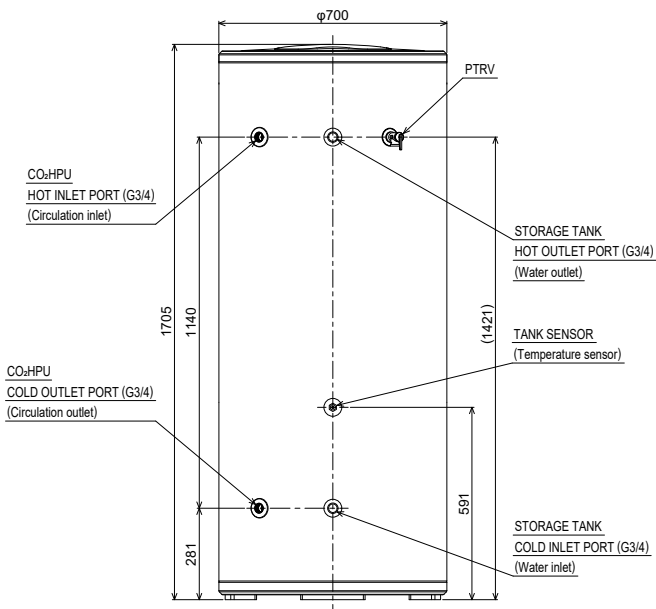
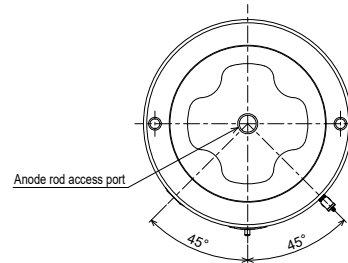
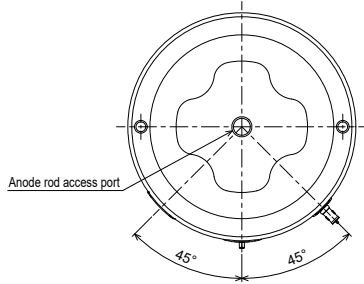

Tank capacity minimum value	400 L	315 L
Total physical volume	408 L	318 L
Weight (Empty)	130 kg	97 kg
Enamel grade	Y grade	
Anode rod material	Magnesium	
Anode rod shape	Φ21 mm / 1450 mm	
Relief valve	PTRV	
Set pressure	850 kPa	
Set temperature	99 °C	

Glass Lined Tank Unit

Dimensional drawings

HE-TM250AHR

Relief Valve (PTRV) Mounting Details

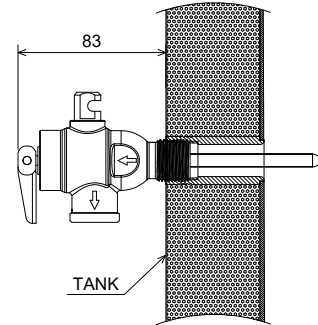
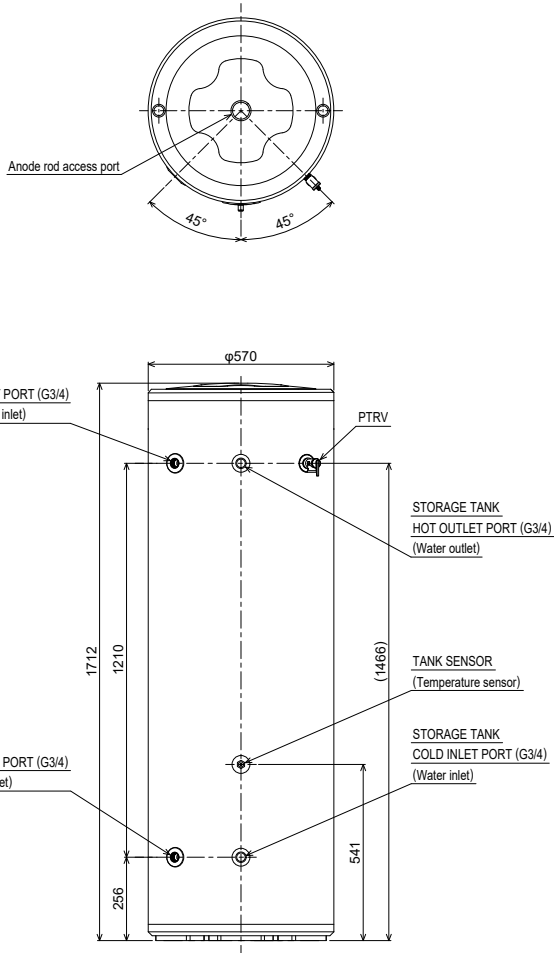

250 L

253 L

90 kg

Y grade

Magnesium

$\Phi 21$  mm / 1450 mm

PTRV

850 kPa

99 °C

# Specifications (Continued)

## Wiring diagram

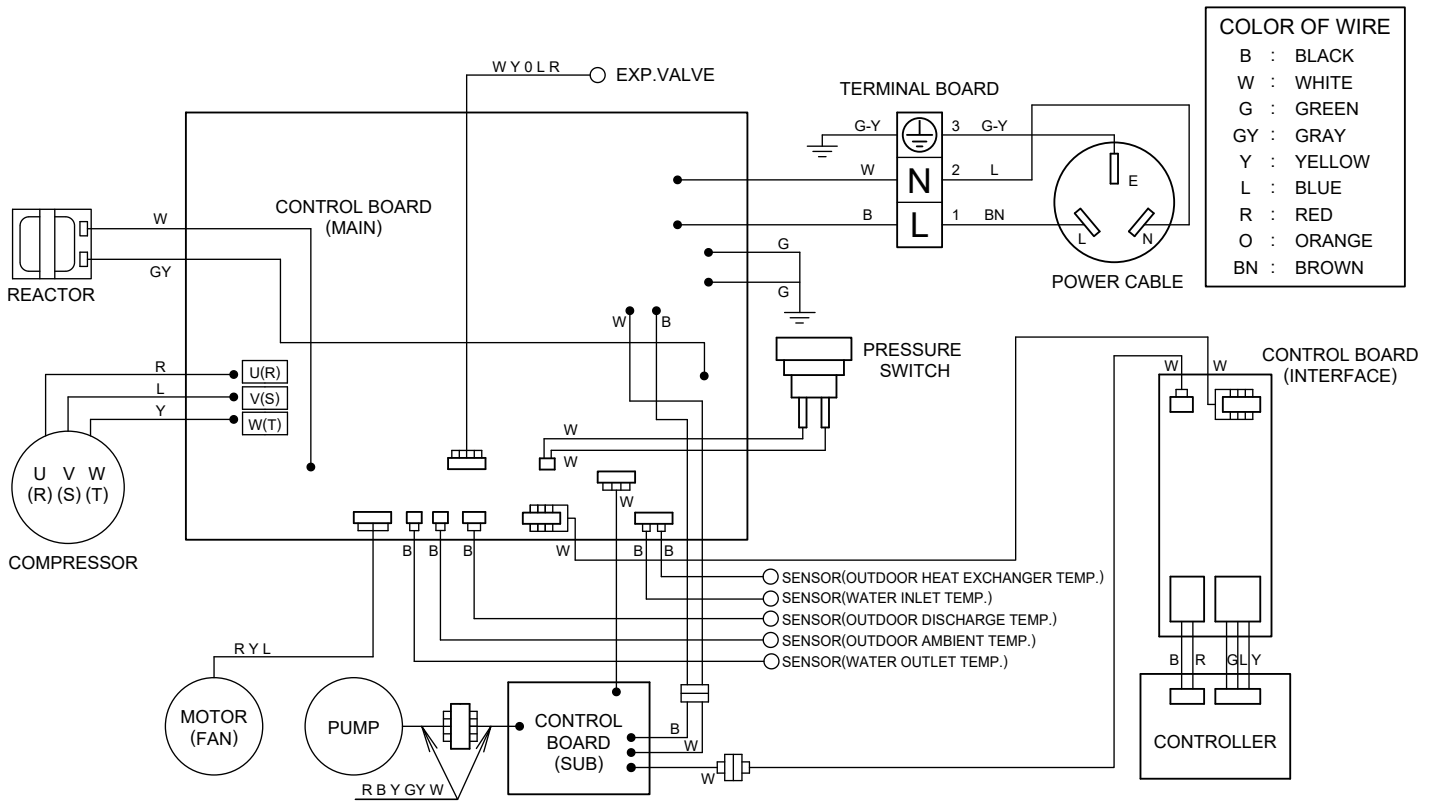

### WARNING

Warning when you fix electric components!



Don't do

- Do not touch electrically charged parts, as electric shock may occur even if they are switched off.



Must do

- Be sure to wait at least 5 min. after turning off the power.



### CAUTION



Don't do

- Do not touch any part of the electric circuit (including the wiring of thermistor and others), as it has high voltage against the ground.



Must do

- Pay attention not to damage the insulated wire when you tighten the screw, as the exposed wire may cause electric shock or malfunction.



Don't do

- Do not ground the oscilloscope when you operate. You might destroy it. Also do not touch any metal part of the oscilloscope while operating.

### How to detach locking terminal

Pull out while holding the housing.

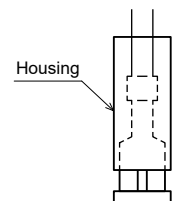

# Using “Panasonic Comfort Cloud” app

“Panasonic Comfort Cloud” app aims to create a comfortable living environment for households using Panasonic products such as the CO<sub>2</sub> heat pump hot water system by providing smart tools that leverage IoT technology.

With this app, you can remotely operate the CO<sub>2</sub> heat pump hot water system anytime, from anywhere. In addition, the app displays the time when hot water was heated and the amount of power consumed, allowing you to clearly see the energy-saving effect.

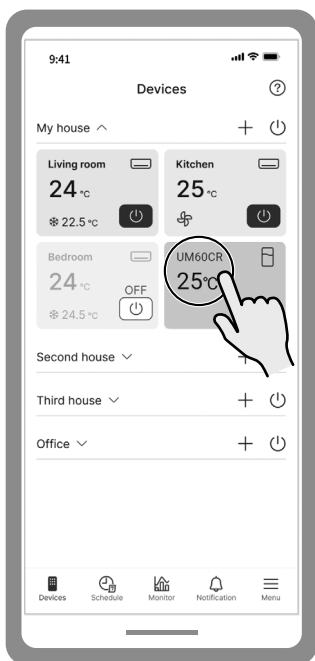

The dedicated app for Panasonic appliances which is registered with the cloud server will be displayed.

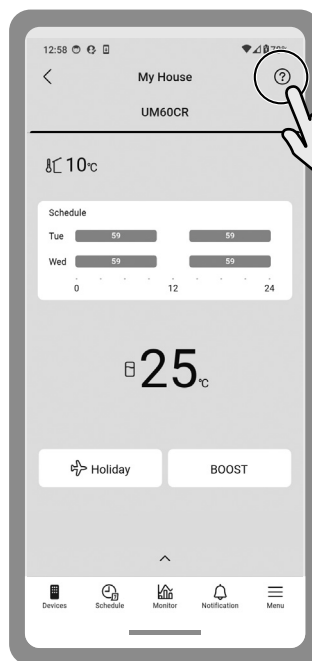

Tap the  icon at the top right of the screen to access the help guide page, where you can check the latest instructions for using the app.

## Contents

### Page

<b>Preparing for Wireless LAN Connection</b>	<b>70</b>
Requirements for using the service	71
Information on wireless LAN function	71
Install the dedicated app	71
<b>Initial Connection</b>	<b>72</b>
Create a Panasonic ID	72
Register with the cloud server via scan setting	72
<b>Add Family Members as Users</b>	<b>74</b>
Share the device	74
Owner	74
Family member	74
<b>Controller Wireless LAN Functions</b>	<b>75</b>
When scan setting cannot be performed	75
Connect to wireless LAN (ON)	76
Disconnect wireless LAN (OFF)	76
Initialise wireless LAN registration information	77
Check wireless LAN signal strength	77
<b>Q&amp;A on Wireless LAN Function</b>	<b>78</b>
When the following message appears on the app	78
Q&A on the app	79

# Preparing for Wireless LAN Connection

By connecting to a wireless LAN and registering the CO<sub>2</sub> heat pump hot water system with the cloud server, you can operate the hot water system from the app on your smartphone.

The first person to create a Panasonic ID and register the CO<sub>2</sub> heat pump hot water system becomes its owner.

You can set the operating schedule of the hot water system via the app according to your family's lifestyle patterns, such as cooking and washing dishes in the kitchen, taking showers, or washing hands.

You can also add family members as users, enabling remote operation of the hot water system from each family member's smartphone.

Wireless LAN icon

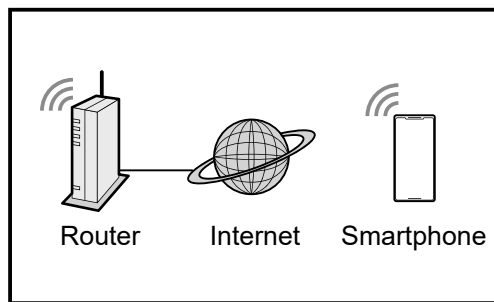
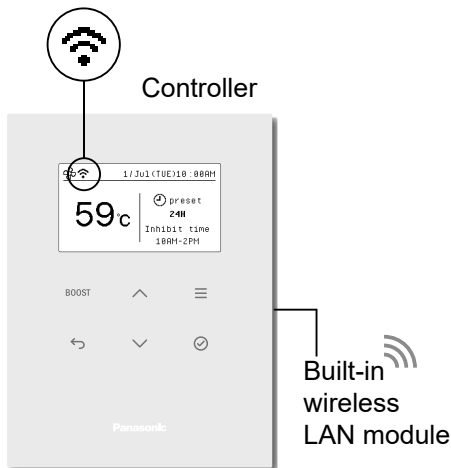

Comfort Cloud

You can operate the hot water system remotely using the "Panasonic Comfort Cloud" app.

## Specifications for the built-in network adapter

Model	PIOTV2 (WA)
Input Voltage	DC 5V (From Controller)
Current Consumption	Tx/Rx max.190/70 mA
Wireless standard	IEEE 802.11 b/g/n; BT 5.0 Low Energy (BLE)
Frequency range	2.4 GHz band
Encryption	WPA™/WPA2™/WPA3™

## Maximum wireless frequency output in the frequency band PIOT-V2(WA)

Type of wireless	Frequency band	Max. EIRP (dBm)
WLAN	2412 - 2472 MHz	20 dBm
BLE	2402 - 2480 MHz	20 dBm

 The wireless LAN icon (lit, flashing, or off) shows the communication status with the wireless LAN router.

Wireless LAN icon 	Communication with Wireless LAN Router
Lights	Normal
Blinks	Not connected / Unstable
Turns off	Wireless LAN : OFF

- If the wireless LAN icon is flashing, wireless communication is either unavailable or unstable. Check that the wireless LAN router is powered on. Also, check the wireless LAN signal strength (P.77) and, if necessary, move the router closer to the controller or take other measures to improve communication.

## NOTE:

- Do not attempt to disassemble or modify the network adapter inside the hot water system (controller).
- Data sent or received over the wireless frequency wave may be intercepted or monitored.
- The dedicated app is free, but installation and communication charges for the service are charged.

## Requirements for using the service

### ■ Internet Environment

A stable internet connection is required. Use a wireless LAN router for the connection. For details, check your contract with your provider or network operator.

- The controller of the hot water system is equipped with a wireless LAN module. Install the wireless LAN router where it can communicate with the controller.

### ■ Wireless LAN Router

(Wireless LAN broadband router)

- Use a wireless LAN router that supports the 2.4 GHz band (communication standards: IEEE802.11b, IEEE802.11g, IEEE802.11n). Routers other than those listed above cannot be used.
- For security, use a wireless LAN router that supports one of the following encryption methods: WPA3, WPA2, or WPA.
  - WPA3 or WPA2 (AES) encryption is recommended.
  - Encryption using TKIP is not supported.
  - For setup instructions, refer to the router's user manual.
- Routers that support only WEP are not compatible.
- Mobile routers are not guaranteed to work.

### ■ Smartphone

To install and use the "Panasonic Comfort Cloud" app on your smartphone, check the OS (Operating System).

- Confirm the compatible OS versions for iOS (iPhone) and Android on the app store installation page. Update the OS version if necessary.
- Use the app after agreeing to the latest terms of use.

## Information on wireless LAN function

### ■ Firmware update function

This product has a function to automatically update the firmware of the device to the latest version by connecting to the Panasonic firmware update server via Internet.

To update the firmware, the device checks once a day whether its own firmware is the latest version after the power is turned on. When the update is required, the update is applied, and the device automatically restarts. Operation is not available while the device is restarting. (Approx. one to five minutes will be taken.)

## Install the dedicated app

- 1 Use your smartphone to install the dedicated app.

### For Android\*<sup>1</sup> user

Launch "Google Play"\*<sup>1</sup> and search for "Panasonic Comfort Cloud".

### For iOS user

Launch "App Store"\*<sup>2</sup> and search for "Panasonic Comfort Cloud".

\*1: Android and Google Play are trademarks or registered trademarks of Google LLC.

\*2: App Store is a service mark of Apple Inc.

You can also check the latest information about the dedicated app and install it from the following URL:

<https://www.panasonic.com/au/hvac/product-top/comfort-cloud.html>



- 2 Install "Panasonic Comfort Cloud".



Comfort Cloud

### NOTE:

- "Panasonic Comfort Cloud" app is free of charge. Please note that communication fees incurred during installation or operation are the responsibility of the customer.

# Initial Connection

## Create a Panasonic ID

The person who mainly uses the dedicated app “Panasonic Comfort Cloud” should register first. The registered ID holder becomes the “owner” of the CO<sub>2</sub> heat pump hot water system.

- 1 Launch the dedicated “Panasonic Comfort Cloud” app and tap “Start”.



- 2 Select “Create account” and enter the required information such as your email address to register.

- If you are already registered, this step is not necessary.
- You can use a “Google account” or “Apple ID” as your Panasonic ID.

- 3 Log in and proceed to the terms of use screen for “Panasonic Comfort Cloud”.

- Agree to the terms of use to start using the app.

## Register with the cloud server via scan setting

The “owner” of the CO<sub>2</sub> heat pump hot water system should register it with the cloud server.

- 1 Initialise the wireless LAN registration information on the CO<sub>2</sub> heat pump hot water system controller.
  - Perform initialisation if previous registration information remains, such as when the system was used by a former resident.
  - Follow the steps in “Initialising the wireless LAN connection information” (P.77).



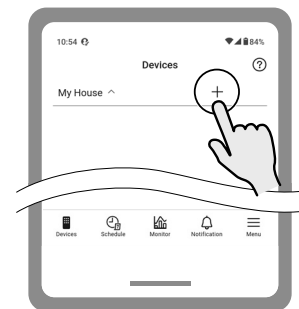

- 2 On the app’s home screen, tap “+” at the top right of “Devices” and proceed to the “Add new device” screen.

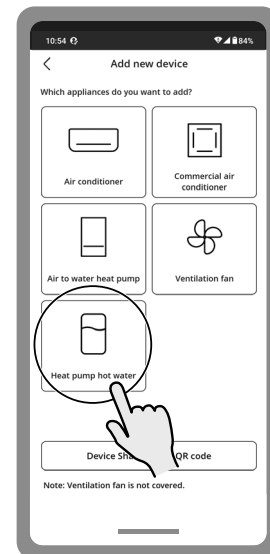

- 3 Tap “Heat pump hot water”.





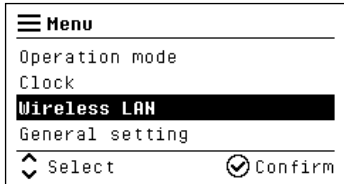

**4** Follow the instructions on the app screen to operate the controller and perform “Scan setting”.

**1** Press Menu .  
Select [Wireless LAN] with  , and press Enter .

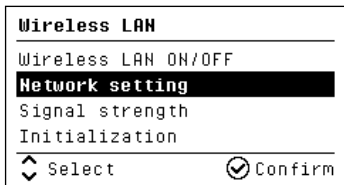

**2** Press Enter  when [Network setting] is displayed.



**3** Select [Scan setting] with  , and press Enter .

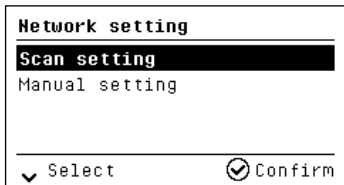

- Follow the instructions on the app screen and scan the QR code\* displayed on the controller screen using your smartphone.
- When the SSID of the wireless LAN router to be connected to the controller is displayed, enter the password.
- If the QR code cannot be scanned, perform “Manual setting”. (Refer to P.75 “When scan setting cannot be performed”)

\*: QR Code is a registered trademark of DENSO WAVE INCORPORATED.

**5** When the model number of the CO<sub>2</sub> heat pump unit starting with “HE-” appears on the app screen, enter the required information and register the “Device Password”.

- The device password is required when performing “Owner settings”.

**6** Set the tank unit capacity, time zone of the installation location, and daylight saving time information.

- When the following message appears on the app screen, cloud server registration is complete. Tap **Start Using** to display the main screen.



- When the controller returns to the main screen and the wireless LAN icon  changes from flashing to lit, remote operation from the dedicated app becomes available.

Wireless LAN icon ON

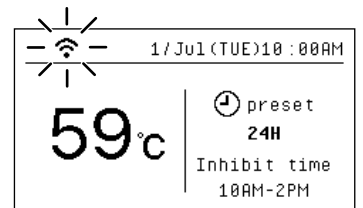

# Add Family Members as Users

## Share the device

Scan the QR code displayed on the app screen of the CO<sub>2</sub> heat pump hot water system owner, and register family members as users. Family members will then be able to use the dedicated app immediately.

## Owner

- 1 Tap  at the bottom of the app's main screen to go to the **Owner settings** screen, then tap **Device Sharing with QR code**.

- Main screen of the app

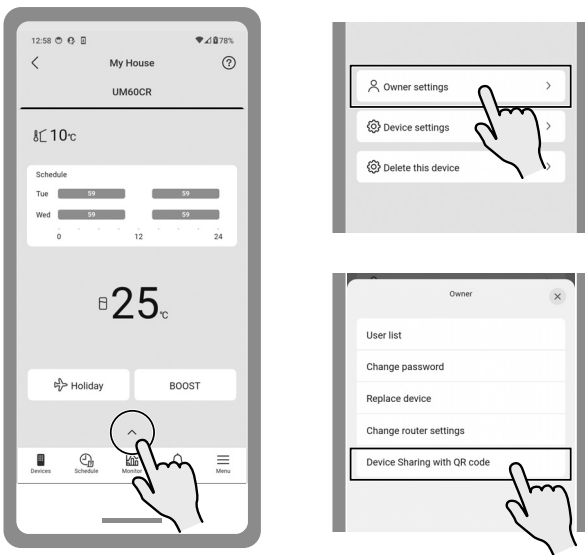

- 2 Set the family member's username and usage permissions.

- After entering the required information, tap **Share this device** at the bottom of the screen. A QR code will be displayed; show it to the family member.

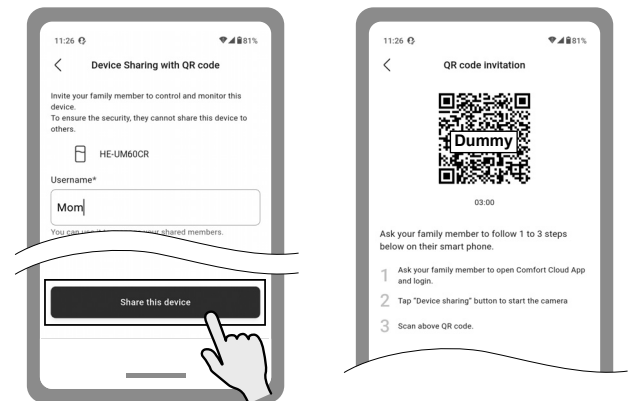

- Share the device one person at a time.
- A new QR code will be displayed after 3 minutes.
- The same QR code cannot be used to register multiple users.

### NOTE:

- You can also share the device via email. For details, follow the instructions on the app screen.

## Family member

- 1 On the app's home screen, tap "+" at the top right of "Devices," then proceed to the "Add new device" screen and tap **Device Sharing with QR code**.

- Home screen "Devices"



- 2 Follow the instructions on the app screen and scan the QR code displayed on the owner's smartphone (see step 2 in "Owner").

- When the main screen appears, device sharing is complete. Remote operation of the CO<sub>2</sub> heat pump hot water system is now available.

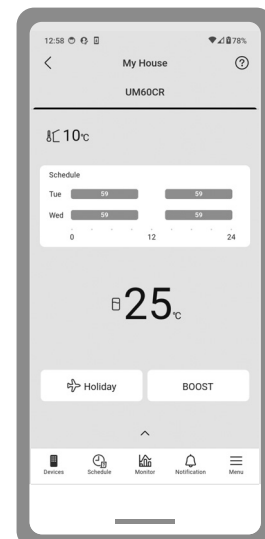

# Controller Wireless LAN Functions

## When scan setting cannot be performed

If the QR code cannot be scanned correctly during “Scan setting,” perform initial connection using “Manual setting”.

- 1 Press Menu 2 times.  
Select [Wireless LAN] with , and press Enter .

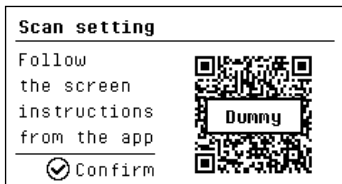

- 2 Press Enter when [Network setting] is displayed.

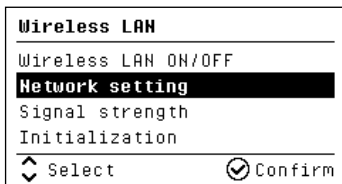

- 3 Select [Manual setting] with , and press Enter .

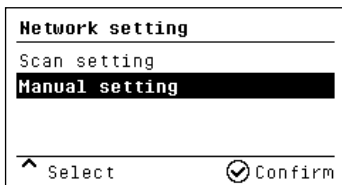

- 4 Follow the instructions on the app screen and press .

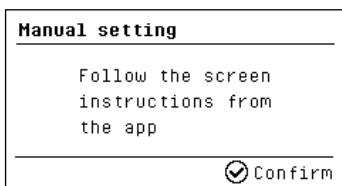

- When the SSID of the wireless LAN router to be connected to the controller is displayed, enter the password.

- 5 When the model number of the CO<sub>2</sub> heat pump unit starting with “HE-” appears on the app screen, enter the required information and register the “Device Password”.

- The device password is required when performing “Owner settings”.

- 6 Set the tank unit capacity, time zone of the installation location, and daylight saving time information.

- When the following message appears on the app screen, cloud server registration is complete.

Tap **Start Using** to display the main screen.



- When the controller returns to the main screen and the wireless LAN icon changes from flashing to lit, remote operation from the dedicated app becomes available.



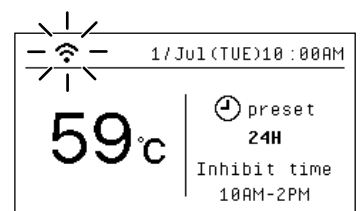

Wireless LAN icon ON





# Controller Wireless LAN Functions (Continued)

## Connect to wireless LAN (ON)

Turn [ON] the power of the wireless LAN module built into the hot water system.

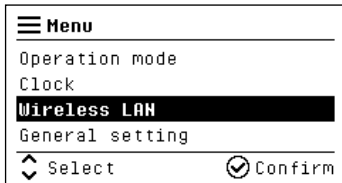
- 1 Press Menu .  
Select [Wireless LAN] with  , and press Enter .



- 2 Press Enter  when [Wireless LAN ON/OFF] is displayed.

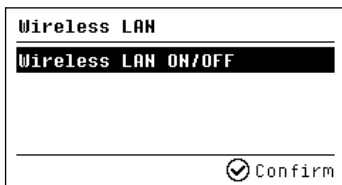

- 3 Select [ON] with  , and press Enter .

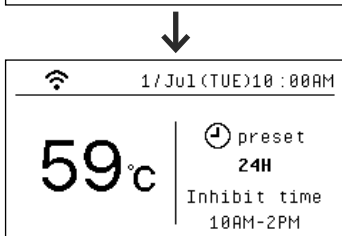
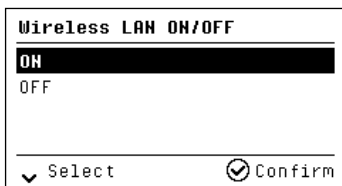



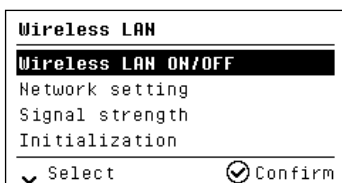

- The wireless LAN icon  is displayed at the top left of the main screen.
- The screen in step 2 changes as shown below after setting the wireless LAN to [ON].



## Disconnect wireless LAN (OFF)

Turn [OFF] the power of the wireless LAN module.

- 1 Press Menu .  
Select [Wireless LAN] with  , and press Enter .

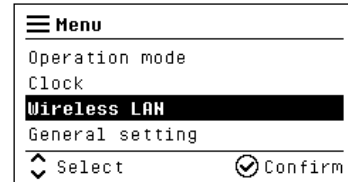

- 2 Press Enter  when [Wireless LAN ON/OFF] is displayed.

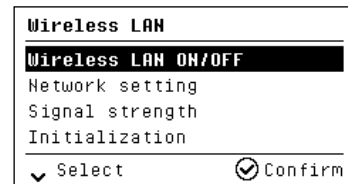

- 3 Select [OFF] with  , and press Enter .

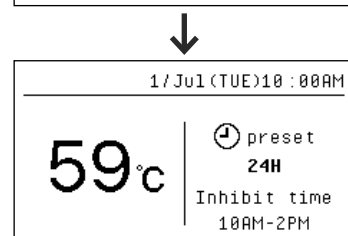
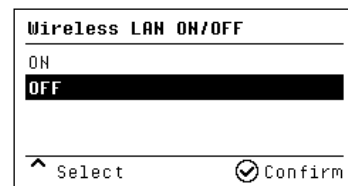

- The wireless LAN icon  at the top left of the main screen turns off.





### NOTE:

- Even if the wireless LAN is set to [OFF], the registration information of the CO<sub>2</sub> heat pump hot water system on the "Panasonic Comfort Cloud" server is not deleted.



## Initialise wireless LAN registration information

Do not perform this operation except the cases shown below. Otherwise, the important information of the CO<sub>2</sub> heat pump hot water system registered on the "Panasonic Comfort Cloud" server is all deleted.

- When deleting all information of the CO<sub>2</sub> heat pump hot water system registered on the server
- When discarding or transferring the hot water system
- When receiving the hot water system from a third party

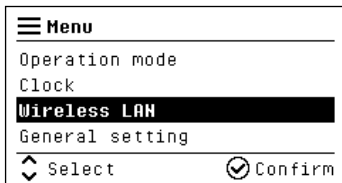
- 1 Press Menu .  
Select [Wireless LAN] with  , and press Enter .



- 2 Select [Initialization] with  , and press Enter .

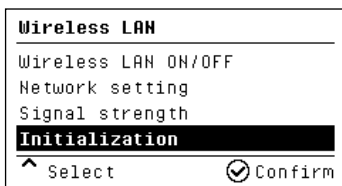



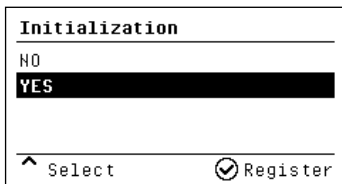

- 3 Select [YES] with  , and press Enter .





## Check wireless LAN signal strength

You can check the signal strength of the wireless LAN communication.

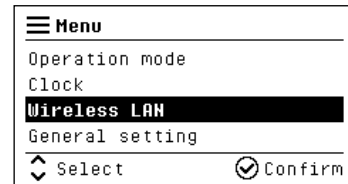



- 1 Press Menu .  
Select [Wireless LAN] with  , and press Enter .

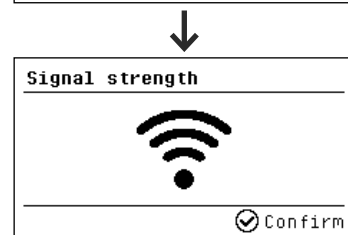
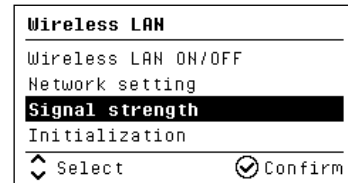

- 2 Select [Signal strength] with  , and press Enter .



- Signal strength is displayed in three levels.



Strong	
Medium	
Weak	
Not detected	

### NOTE:



- Check the wireless LAN signal strength after the initial connection between the controller, CO<sub>2</sub> heat pump hot water system, and wireless LAN router is complete. If the initial connection is not complete,  is displayed regardless of signal strength.

# Q&A on Wireless LAN Function

When the following message appears on the app

Symptom	Cause	Page
<p>“QR code scanning error.” is displayed</p>	<ul style="list-style-type: none"> <li>● The QR code shown on the CO<sub>2</sub> heat pump hot water system controller could not be scanned by the smartphone. Follow the instructions on the app screen and perform “Scan setting” again. → If the error still appears, perform “Manual setting”.</li> </ul>	<p>P.72 - 73  P.75</p>
<p>“Failed to connect to heat pump hot water.” is displayed</p>	<ul style="list-style-type: none"> <li>● Devices that emit radio waves, such as microwave ovens or mobile phones, may use the same 2.4 GHz frequency band. Using them simultaneously may interrupt communication with the hot water system controller. Avoid using such devices nearby at the same time. → Follow the instructions on the app screen and try again.</li> </ul>	<p>P.72 - 73</p>
<p> “H94 No water supply” is displayed</p>	<ul style="list-style-type: none"> <li>● Refer to “When the controller indicates an error.” for troubleshooting. → If the error still appears, contact your dealer.</li> </ul>	<p>P.37</p>
<p> Error messages such as H____, F____ are displayed</p>	<ul style="list-style-type: none"> <li>● Check the error indication on the control screen, and contact the dealer where the product has been purchased.</li> </ul>	<p>P.37</p>

## Q&A on the app

Symptom	Cause	Page
"Panasonic Comfort Cloud" app cannot be installed	<ul style="list-style-type: none"> <li>● The smartphone OS (Operating System) may not be compatible with the dedicated app. Check the compatible OS versions for iOS (iPhone) and Android on the installation page of each app store. → Update the OS version if necessary.</li> </ul>	P.71
Cannot connect the hot water system controller to the wireless LAN router	<ul style="list-style-type: none"> <li>● Make sure the wireless LAN router is set to connect using the 2.4 GHz frequency band. 5.0 GHz cannot be used.</li> <li>● Connection methods and security settings may vary depending on the router. For details, refer to the router's user manual.</li> </ul>	P.71
Cannot register with the cloud server	<ul style="list-style-type: none"> <li>● Business networks that require server login are not supported. → If the IP address is filtered or blocked, the system cannot be used. Prepare another wireless LAN router. Set the router as follows: Port: 443 URL: <a href="http://ldcws.pcpf.panasonic.com">ldcws.pcpf.panasonic.com</a></li> </ul>	—
Wireless LAN icon  on the controller screen is flashing (Cloud server registration is complete)	<ul style="list-style-type: none"> <li>● Check "Wireless LAN signal strength" on the controller. If the signal strength does not show "Strong", communication may be unstable. → Improve communication by changing the installation position of the wireless LAN router.</li> </ul>	P.77
Suspicious access such as unexpected changes to controller settings or the dedicated app	<ul style="list-style-type: none"> <li>● Performing "Initialising the hot water system" will restore the controller to factory settings.</li> </ul>	P.16
	<ul style="list-style-type: none"> <li>● Perform "Initialise wireless LAN registration information" using the CO<sub>2</sub> heat pump hot water system controller. → Cloud server registration information for the owner and family users will be erased, so perform initial connection again.</li> </ul>	P.77 P.72 - 74
Daylight saving time is not displayed correctly	<ul style="list-style-type: none"> <li>● Daylight saving time must be set from the dedicated app. Tap  at the bottom of the main screen, go to "Device settings", and set "Time zone" and "Summer Time" correctly.</li> </ul>	—
	<ul style="list-style-type: none"> <li>● Operate the CO<sub>2</sub> heat pump hot water system controller to set "Date and time" correctly.</li> </ul>	P.17
When changing your smartphone model	<ul style="list-style-type: none"> <li>● Make sure the smartphone OS (Operating System) version is compatible with the dedicated app. Install and launch the "Panasonic Comfort Cloud" app and log in with your Panasonic ID. → The dedicated app can continue to be used.</li> </ul>	P.71
When adding family members as users	<ul style="list-style-type: none"> <li>● The owner of the CO<sub>2</sub> heat pump hot water system must launch the dedicated app and perform "Device Sharing". (Only the owner can do this.) → Refer to "Add Family Members as Users" for instructions.</li> </ul>	P.74
When changing the wireless LAN router	<ul style="list-style-type: none"> <li>● The owner of the CO<sub>2</sub> heat pump hot water system must perform connection settings again using the dedicated app. (Only the owner can do this.) → Tap  at the bottom of the main screen, go to "Owner settings" &gt; "Change router settings", and follow the instructions on the app screen.</li> </ul>	—

# Q&A on Wireless LAN Function (Continued)

## Q&A on the app (Continued)

Symptom	Cause	Page
When the controller is replaced during repair (including simultaneous replacement of other parts or CO <sub>2</sub> heat pump unit)	<ul style="list-style-type: none"> <li>● Controller replacement must be performed by a Panasonic authorised service provider.</li> <li>● The owner of the CO<sub>2</sub> heat pump hot water system must perform connection settings again using the dedicated app. (Only the owner can do this.) → Tap  at the bottom of the main screen, go to “Owner settings” &gt; “Replace device”, and follow the instructions on the app screen.</li> </ul>	—
When parts or units other than the controller are replaced during repair (including CO <sub>2</sub> heat pump unit or tank unit replacement)	<ul style="list-style-type: none"> <li>● Part replacement must be performed by a Panasonic authorised service provider.</li> </ul>	—
When discontinuing use of the CO <sub>2</sub> heat pump hot water system... When transferring or disposing of the unit...	<ul style="list-style-type: none"> <li>● Use the controller or the dedicated app to reset the settings and delete usage and wireless LAN connection information</li> <li>● Turn off the power to the CO<sub>2</sub> heat pump hot water system and drain the water.</li> </ul>	P.16 P.77  P.31

# Copyrights, etc. (OSS)

- Software licence information.
  - App Store is a service mark of Apple Inc.
  - iPhone is a trademark of Apple Inc. in the United States and other countries.
  - Android and Google Play are trademarks or registered trademarks of Google LLC.
  - "WPA™", "WPA2™", and "WPA3™" are trademarks of "Wi-Fi Alliance®".
  - Panasonic uses these marks under respective licences. Other trademarks and trade names are the properties of their respective owners.
  - Other names, company names, product names, etc. that appear in this manual are trademarks or registered trademarks of respective companies. Some of the TMs and ® marks may not be described in the main texts.
- The software embedded into this product is shown below.
  - 1) Software independently developed by Panasonic Corporation or developed for the company,
  - 2) Software owned by a third party and licenced to Panasonic Corporation,
  - 3) Open source software licenced under the condition that the source code disclosure is not demanded.

The software classified into (3) above is distributed to be made available as a standalone product, however, there is no guarantee. All types of guarantees including an implicit guarantee related to especially merchantability and compatibility with specific purposes are denied.

```
{cJSON}
Copyright (c) 2009 Dave Gamble
Copyright (c) 2009-2017 Dave Gamble and cJSON contributors
```

Permission is hereby granted, free of charge, to any person obtaining a copy of this software and associated documentation files (the "Software"), to deal in the Software without restriction, including without limitation the rights to use, copy, modify, merge, publish, distribute, sublicense, and/or sell copies of the Software, and to permit persons to whom the Software is furnished to do so, subject to the following conditions:

The above copyright notice and this permission notice shall be included in all copies or substantial portions of the Software.

THE SOFTWARE IS PROVIDED "AS IS", WITHOUT WARRANTY OF ANY KIND, EXPRESS OR IMPLIED, INCLUDING BUT NOT LIMITED TO THE WARRANTIES OF MERCHANTABILITY, FITNESS FOR A PARTICULAR PURPOSE AND NONINFRINGEMENT. IN NO EVENT SHALL THE AUTHORS OR COPYRIGHT HOLDERS BE LIABLE FOR ANY CLAIM, DAMAGES OR OTHER LIABILITY, WHETHER IN AN ACTION OF CONTRACT, TORT OR OTHERWISE, ARISING FROM, OUT OF OR IN CONNECTION WITH THE SOFTWARE OR THE USE OR OTHER DEALINGS IN THE SOFTWARE.

```
{wpa_supplicant}
Copyright (c) 2005-2009, Jouni Malinen <j@w1.fi>
Copyright (c) 2008, Jouni Malinen <j@w1.fi>
```

```
wpa_supplicant
=====
```

Copyright (c) 2003-2019, Jouni Malinen <j@w1.fi> and contributors  
All Rights Reserved.

This program is licensed under the BSD license (the one with advertisement clause removed).

If you are submitting changes to the project, please see CONTRIBUTIONS file for more instructions.

License

```
-----
This software may be distributed, used, and modified under the terms of BSD license:
```

Redistribution and use in source and binary forms, with or without modification, are permitted provided that the following conditions are met:

1. Redistributions of source code must retain the above copyright notice, this list of conditions and the following disclaimer.
2. Redistributions in binary form must reproduce the above copyright notice, this list of conditions and the following disclaimer in the documentation and/or other materials provided with the distribution.
3. Neither the name(s) of the above-listed copyright holder(s) nor the names of its contributors may be used to endorse or promote products derived from this software without specific prior written permission.

THIS SOFTWARE IS PROVIDED BY THE COPYRIGHT HOLDERS AND CONTRIBUTORS "AS IS" AND ANY EXPRESS OR IMPLIED WARRANTIES, INCLUDING, BUT NOT LIMITED TO, THE IMPLIED WARRANTIES OF MERCHANTABILITY AND FITNESS FOR A PARTICULAR PURPOSE ARE DISCLAIMED. IN NO EVENT SHALL THE COPYRIGHT OWNER OR CONTRIBUTORS BE LIABLE FOR ANY DIRECT, INDIRECT, INCIDENTAL, SPECIAL, EXEMPLARY, OR CONSEQUENTIAL DAMAGES (INCLUDING, BUT NOT LIMITED TO, PROCUREMENT OF SUBSTITUTE GOODS OR SERVICES; LOSS OF USE, DATA, OR PROFITS; OR BUSINESS INTERRUPTION) HOWEVER CAUSED AND ON ANY THEORY OF LIABILITY, WHETHER IN CONTRACT, STRICT LIABILITY, OR TORT (INCLUDING NEGLIGENCE OR OTHERWISE) ARISING IN ANY WAY OUT OF THE USE OF THIS SOFTWARE, EVEN IF ADVISED OF THE POSSIBILITY OF SUCH DAMAGE.

```
{CMSIS}
Copyright (c) 2017 STMicroelectronics. All rights reserved.
Copyright (c) 2009-2017 ARM Limited. All rights reserved.
Copyright (c) 2009-2018 Arm Limited. All rights reserved.
Copyright (c) 2017-2018 Arm Limited. All rights reserved.
```

# Copyrights, etc. (OSS) (Continued)

Copyright (c) 2017-2018 IAR Systems

{Mbed TLS}

Copyright (C) 2006-2015, ARM Limited, All Rights Reserved  
Copyright (C) 2006-2016, ARM Limited, All Rights Reserved  
Copyright (C) 2006-2017, ARM Limited, All Rights Reserved  
Copyright (C) 2006-2018, ARM Limited, All Rights Reserved  
Copyright (C) 2006-2018, Arm Limited (or its affiliates), All Rights Reserved  
Copyright (C) 2006-2018, Arm Limited (or its affiliates), All Rights Reserved.  
Copyright (C) 2006-2019, ARM Limited, All Rights Reserved  
Copyright (C) 2006-2019, Arm Limited (or its affiliates), All Rights Reserved  
Copyright (C) 2016, ARM Limited, All Rights Reserved  
Copyright (C) 2016-2018, ARM Limited, All Rights Reserved  
Copyright (C) 2018, Arm Limited (or its affiliates), All Rights Reserved  
Copyright (C) 2018, Arm Limited, All Rights Reserved  
Copyright The Mbed TLS Contributors

{RealtekSDK}

(C) COPYRIGHT 2011 STMicroelectronics  
(c) COPYRIGHT 2017 Realtek Semiconductor Corporation  
Copyright (C) 2019 Amazon.com, Inc. or its affiliates. All Rights Reserved.  
Copyright (c) 2006-2013 ARM Limited  
Copyright (c) 2009-2016 ARM Limited. All rights reserved.  
Copyright (c) 2009-2017 ARM Limited. All rights reserved.  
Copyright (c) 2009-2018 Arm Limited. All rights reserved.  
Copyright (c) 2013 ARM LIMITED All rights reserved.  
Copyright (c) 2013 Realtek Semiconductor Corp.  
Copyright (c) 2013-2016 Realtek Semiconductor Corp.  
Copyright (c) 2014, Realtek Semiconductor Corp. All rights reserved.  
Copyright (c) 2015, Realsil Semiconductor Corporation. All rights reserved.  
Copyright (c) 2015, Realtek Semiconductor Corp. All rights reserved.  
Copyright (c) 2015, Realtek Semiconductor Corporation. All rights reserved.  
Copyright (c) 2017, Realsil Semiconductor Corporation. All rights reserved.  
Copyright (c) 2017, Realtek Semiconductor Corporation. All rights reserved.  
Copyright (c) 2017-2018 Arm Limited. All rights reserved.  
Copyright 2014 Tencent. All rights reserved.  
Copyright(c) 2007 - 2012 Realtek Corporation. All rights reserved.  
Copyright(c) 2007 - 2016 Realtek Corporation. All rights reserved.  
Copyright(c) 2007 - 2017 Realtek Corporation. All rights reserved.  
Copyright(c) 2007 - 2018 Realtek Corporation. All rights reserved.  
Copyright(c) 2014, Realtek Semiconductor Corporation. All rights reserved.  
Copyright(c) 2015, Realtek Semiconductor Corporation. All rights reserved.  
Copyright(c) 2016, Realtek Semiconductor Corporation. All rights reserved.  
Copyright(c) 2017, Realtek Semiconductor Corporation. All rights reserved.  
Copyright(c) 2019, Realtek Semiconductor Corporation. All rights reserved.  
copyright Kulesh Shanmugasundaram (kulesh [squiggly] isis.poly.edu)

Apache License  
Version 2.0, January 2004  
<http://www.apache.org/licenses/>

## TERMS AND CONDITIONS FOR USE, REPRODUCTION, AND DISTRIBUTION

### 1. Definitions.

"License" shall mean the terms and conditions for use, reproduction, and distribution as defined by Sections 1 through 9 of this document.

"Licensor" shall mean the copyright owner or entity authorized by the copyright owner that is granting the License.

"Legal Entity" shall mean the union of the acting entity and all other entities that control, are controlled by, or are under common control with that entity. For the purposes of this definition, "control" means (i) the power, direct or indirect, to cause the direction or management of such entity, whether by contract or otherwise, or (ii) ownership of fifty percent (50%) or more of the outstanding shares, or (iii) beneficial ownership of such entity.

"You" (or "Your") shall mean an individual or Legal Entity exercising permissions granted by this License.

"Source" form shall mean the preferred form for making modifications, including but not limited to software source code, documentation source, and configuration files.

"Object" form shall mean any form resulting from mechanical transformation or translation of a Source form, including but not limited to compiled object code, generated documentation, and conversions to other media types.

"Work" shall mean the work of authorship, whether in Source or Object form, made available under the License, as indicated by a copyright notice that is included in or attached to the work (an example is provided in the Appendix below).

"Derivative Works" shall mean any work, whether in Source or Object form, that is based on (or derived from) the Work and for which the editorial revisions, annotations, elaborations, or other modifications represent, as a whole, an original work of authorship. For the purposes of this License, Derivative Works shall not include works that remain separable from, or merely link (or bind by name) to the interfaces of, the Work and Derivative Works thereof.

"Contribution" shall mean any work of authorship, including the original version of the Work and any modifications or additions to that Work or Derivative Works thereof, that is intentionally submitted to Licensor for inclusion in the Work by the copyright owner or by an individual or Legal Entity authorized to submit on behalf of the copyright owner. For the purposes of this definition, "submitted" means any form of electronic, verbal, or written communication sent to the Licensor or its representatives, including but not limited to communication on electronic mailing lists, source code control systems, and issue tracking systems that are managed by, or on behalf of, the Licensor for the purpose of discussing and improving the Work, but excluding communication that is conspicuously marked or otherwise designated in writing by the copyright owner as "Not a Contribution."

"Contributor" shall mean Licensor and any individual or Legal Entity on behalf of whom a Contribution has been received by Licensor and subsequently incorporated within the Work.

2. Grant of Copyright License. Subject to the terms and conditions of this License, each Contributor hereby grants to You a perpetual, worldwide, non-exclusive, no-charge, royalty-free, irrevocable copyright license to reproduce, prepare Derivative Works of, publicly display, publicly perform, sublicense, and distribute the Work and such Derivative Works in Source or Object form.
3. Grant of Patent License. Subject to the terms and conditions of this License, each Contributor hereby grants to You a perpetual, worldwide, non-exclusive, no-charge, royalty-free, irrevocable (except as stated in this section) patent license to make, have made, use, offer to sell, sell, import, and otherwise transfer the Work, where such license applies only to those patent claims licensable by such Contributor that are necessarily infringed by their Contribution(s) alone or by combination of their Contribution(s) with the Work to which such Contribution(s) was submitted. If You institute patent litigation against any entity (including a cross-claim or counterclaim in a lawsuit) alleging that the Work or a Contribution incorporated within the Work constitutes direct or contributory patent infringement, then any patent licenses granted to You under this License for that Work shall terminate as of the date such litigation is filed.
4. Redistribution. You may reproduce and distribute copies of the Work or Derivative Works thereof in any medium, with or without modifications, and in Source or Object form, provided that You meet the following conditions:
  - (a) You must give any other recipients of the Work or Derivative Works a copy of this License; and
  - (b) You must cause any modified files to carry prominent notices stating that You changed the files; and
  - (c) You must retain, in the Source form of any Derivative Works that You distribute, all copyright, patent, trademark, and attribution notices from the Source form of the Work, excluding those notices that do not pertain to any part of the Derivative Works; and
  - (d) If the Work includes a "NOTICE" text file as part of its distribution, then any Derivative Works that You distribute must include a readable copy of the attribution notices contained within such NOTICE file, excluding those notices that do not pertain to any part of the Derivative Works, in at least one of the following places: within a NOTICE text file distributed as part of the Derivative Works; within the Source form or documentation, if provided along with the Derivative Works; or, within a display generated by the Derivative Works, if and wherever such third-party notices normally appear. The contents of the NOTICE file are for informational purposes only and do not modify the License. You may add Your own attribution notices within Derivative Works that You distribute, alongside or as an addendum to the NOTICE text from the Work, provided that such additional attribution notices cannot be construed as modifying the License.

You may add Your own copyright statement to Your modifications and may provide additional or different license terms and conditions for use, reproduction, or distribution of Your modifications, or for any such Derivative Works as a whole, provided Your use, reproduction, and distribution of the Work otherwise complies with the conditions stated in this License.

5. Submission of Contributions. Unless You explicitly state otherwise, any Contribution intentionally submitted for inclusion in the Work by You to the Licensor shall be under the terms and conditions of this License, without any additional terms or conditions. Notwithstanding the above, nothing herein shall supersede or modify the terms of any separate license agreement you may have executed with Licensor regarding such Contributions.
6. Trademarks. This License does not grant permission to use the trade names, trademarks, service marks, or product names of the Licensor, except as required for reasonable and customary use in describing the origin of the Work and reproducing the content of the NOTICE file.
7. Disclaimer of Warranty. Unless required by applicable law or agreed to in writing, Licensor provides the Work (and each Contributor provides its Contributions) on an "AS IS" BASIS, WITHOUT WARRANTIES OR CONDITIONS OF ANY KIND, either express or implied, including, without limitation, any warranties or conditions of TITLE, NON-INFRINGEMENT, MERCHANTABILITY, or FITNESS FOR A PARTICULAR PURPOSE. You are solely responsible for determining the appropriateness of using or redistributing the Work and assume any risks associated with Your exercise of permissions under this License.
8. Limitation of Liability. In no event and under no legal theory, whether in tort (including negligence), contract, or otherwise, unless required by applicable law (such as deliberate and grossly negligent acts) or agreed to in writing, shall any Contributor be liable to You for damages, including any direct, indirect, special, incidental, or consequential damages of any character arising as a result of this License or out of the use or inability to use the Work (including but not limited to damages for loss of goodwill, work stoppage, computer failure or malfunction, or any and all other commercial damages or losses), even if such Contributor has been advised of the possibility of such damages.
9. Accepting Warranty or Additional Liability. While redistributing the Work or Derivative Works thereof, You may choose to offer, and charge a fee for, acceptance of support, warranty, indemnity, or other liability obligations and/or rights consistent with this License. However, in accepting such obligations, You may act only on Your own behalf and on Your sole responsibility, not on behalf of any other Contributor, and only if You agree to indemnify, defend, and hold each Contributor harmless for any liability incurred by, or claims asserted against, such Contributor by reason of your accepting any such warranty or additional liability.

## END OF TERMS AND CONDITIONS

### APPENDIX: How to apply the Apache License to your work.

To apply the Apache License to your work, attach the following boilerplate notice, with the fields enclosed by brackets "[]" replaced with your own identifying information. (Don't include the brackets!) The text should be enclosed in the appropriate comment syntax for the file format. We also recommend that a file or class name and description of purpose be included on the same "printed page" as the copyright notice for easier identification within third-party archives.

Copyright [yyyy] [name of copyright owner]

Licensed under the Apache License, Version 2.0 (the "License"); you may not use this file except in compliance with the License.

You may obtain a copy of the License at

<http://www.apache.org/licenses/LICENSE-2.0>

Unless required by applicable law or agreed to in writing, software distributed under the License is distributed on an "AS IS" BASIS, WITHOUT WARRANTIES OR CONDITIONS OF ANY KIND, either express or implied. See the License for the specific language governing permissions and limitations under the License.

{lwIP}

Copyright (c) 1997 Global Election Systems Inc.

Copyright (c) 2001-2003 Swedish Institute of Computer Science.

Copyright (c) 2001-2003 Swedish Institute of Computer Science. All rights reserved.

Copyright (c) 2001-2004 Axon Digital Design B.V., The Netherlands. All rights reserved.

Copyright (c) 2001-2004 Leon Woestenberg <leon.woestenberg@gmx.net>

Copyright (c) 2001-2004 Swedish Institute of Computer Science. All rights reserved.

Copyright (c) 2002 CITEL Technologies Ltd. All rights reserved.

Copyright (c) 2002-2003, Adam Dunkels.

Copyright (c) 2002-2003, Adam Dunkels. All rights reserved.

Copyright (c) 2003 by Marc Boucher, Services Informatiques (MBSI) inc.

Copyright (c) 2003-2004 Axon Digital Design B.V., The Netherlands. All rights reserved.

Copyright (c) 2003-2004 Leon Woestenberg <leon.woestenberg@axon.tv>

Copyright (c) 2007 Dominik Spies <kontakt@dspies.de> All rights reserved.

Copyright (c) 2010 Inico Technologies Ltd. All rights reserved.

Copyright (c) 2016 The MINIX 3 Project. All rights reserved.

/\*

\* Copyright (c) 2001, 2002 Swedish Institute of Computer Science.

\* All rights reserved.

\*

\* Redistribution and use in source and binary forms, with or without modification, are permitted provided that the following conditions are met:

\*

\* 1. Redistributions of source code must retain the above copyright notice, this list of conditions and the following disclaimer.

\* 2. Redistributions in binary form must reproduce the above copyright notice, this list of conditions and the following disclaimer in the documentation and/or other materials provided with the distribution.

\* 3. The name of the author may not be used to endorse or promote products derived from this software without specific prior written permission.

\*

\* THIS SOFTWARE IS PROVIDED BY THE AUTHOR "AS IS" AND ANY EXPRESS OR IMPLIED WARRANTIES, INCLUDING, BUT NOT LIMITED TO, THE IMPLIED WARRANTIES OF MERCHANTABILITY AND FITNESS FOR A PARTICULAR PURPOSE ARE DISCLAIMED. IN NO EVENT SHALL THE AUTHOR BE LIABLE FOR ANY DIRECT, INDIRECT, INCIDENTAL, SPECIAL, EXEMPLARY, OR CONSEQUENTIAL DAMAGES (INCLUDING, BUT NOT LIMITED TO, PROCUREMENT OF SUBSTITUTE GOODS OR SERVICES; LOSS OF USE, DATA, OR PROFITS; OR BUSINESS INTERRUPTION) HOWEVER CAUSED AND ON ANY THEORY OF LIABILITY, WHETHER IN CONTRACT, STRICT LIABILITY, OR TORT (INCLUDING NEGLIGENCE OR OTHERWISE) ARISING IN ANY WAY OUT OF THE USE OF THIS SOFTWARE, EVEN IF ADVISED OF THE POSSIBILITY OF SUCH DAMAGE.

\*

\* This file is part of the lwIP TCP/IP stack.

\*

\*/ Author: Adam Dunkels <adam@sics.se>

{FreeRTOS}

Copyright (C) 2017 Amazon.com, Inc. or its affiliates. All Rights Reserved.

Copyright (C) 2019 Amazon.com, Inc. or its affiliates. All Rights Reserved.

The FreeRTOS kernel is released under the MIT open source license, the text of which is provided below.

This license covers the FreeRTOS kernel source files, which are located in the /FreeRTOS/Source directory of the official FreeRTOS kernel download. It also covers most of the source files in the demo application projects, which are located in the /FreeRTOS/Demo directory of the official FreeRTOS download. The demo projects may also include third party software that is not part of FreeRTOS and is licensed separately to FreeRTOS. Examples of third party software includes header files provided by chip or tools vendors, linker scripts, peripheral drivers, etc. All the software in subdirectories of the /FreeRTOS directory is either open source or distributed with permission, and is free for use. For the avoidance of doubt, refer to the comments at the top of each source file.

License text:

-----

Copyright (C) 2019 Amazon.com, Inc. or its affiliates. All Rights Reserved.

# Copyrights, etc. (OSS) (Continued)

Permission is hereby granted, free of charge, to any person obtaining a copy of this software and associated documentation files (the "Software"), to deal in the Software without restriction, including without limitation the rights to use, copy, modify, merge, publish, distribute, sublicense, and/or sell copies of the Software, and to permit persons to whom the Software is furnished to do so, subject to the following conditions:

The above copyright notice and this permission notice shall be included in all copies or substantial portions of the Software.

THE SOFTWARE IS PROVIDED "AS IS", WITHOUT WARRANTY OF ANY KIND, EXPRESS OR IMPLIED, INCLUDING BUT NOT LIMITED TO THE WARRANTIES OF MERCHANTABILITY, FITNESS FOR A PARTICULAR PURPOSE AND NONINFRINGEMENT. IN NO EVENT SHALL THE AUTHORS OR COPYRIGHT HOLDERS BE LIABLE FOR ANY CLAIM, DAMAGES OR OTHER LIABILITY, WHETHER IN AN ACTION OF CONTRACT, TORT OR OTHERWISE, ARISING FROM, OUT OF OR IN CONNECTION WITH THE SOFTWARE OR THE USE OR OTHER DEALINGS IN THE SOFTWARE.

{easy-ec}
Copyright (c) 2013, Kenneth MacKay
All rights reserved.

Redistribution and use in source and binary forms, with or without modification, are permitted provided that the following conditions are met:
\* Redistributions of source code must retain the above copyright notice, this list of conditions and the following disclaimer.
\* Redistributions in binary form must reproduce the above copyright notice, this list of conditions and the following disclaimer in the documentation and/or other materials provided with the distribution.

THIS SOFTWARE IS PROVIDED BY THE COPYRIGHT HOLDERS AND CONTRIBUTORS "AS IS" AND ANY EXPRESS OR IMPLIED WARRANTIES, INCLUDING, BUT NOT LIMITED TO, THE IMPLIED WARRANTIES OF MERCHANTABILITY AND FITNESS FOR A PARTICULAR PURPOSE ARE DISCLAIMED. IN NO EVENT SHALL THE COPYRIGHT HOLDER OR CONTRIBUTORS BE LIABLE FOR ANY DIRECT, INDIRECT, INCIDENTAL, SPECIAL, EXEMPLARY, OR CONSEQUENTIAL DAMAGES (INCLUDING, BUT NOT LIMITED TO, PROCUREMENT OF SUBSTITUTE GOODS OR SERVICES; LOSS OF USE, DATA, OR PROFITS; OR BUSINESS INTERRUPTION) HOWEVER CAUSED AND ON ANY THEORY OF LIABILITY, WHETHER IN CONTRACT, STRICT LIABILITY, OR TORT (INCLUDING NEGLIGENCE OR OTHERWISE) ARISING IN ANY WAY OUT OF THE USE OF THIS SOFTWARE, EVEN IF ADVISED OF THE POSSIBILITY OF SUCH DAMAGE.

{STM32CubeF4 HAL}
Copyright (c) 2016 STMicroelectronics. All rights reserved.
Copyright (c) 2017 STMicroelectronics. All rights reserved.
Copyright (c) 2018 STMicroelectronics. All rights reserved.
Copyright (c) 2021 STMicroelectronics. All rights reserved.

Redistribution and use in source and binary forms, with or without modification, are permitted provided that the following conditions are met:

1. Redistributions of source code must retain the above copyright notice, this list of conditions and the following disclaimer.
2. Redistributions in binary form must reproduce the above copyright notice, this list of conditions and the following disclaimer in the documentation and/or other materials provided with the distribution.
3. Neither the name of the copyright holder nor the names of its contributors may be used to endorse or promote products derived from this software without specific prior written permission.

THIS SOFTWARE IS PROVIDED BY THE COPYRIGHT HOLDERS AND CONTRIBUTORS "AS IS" AND ANY EXPRESS OR IMPLIED WARRANTIES, INCLUDING, BUT NOT LIMITED TO, THE IMPLIED WARRANTIES OF MERCHANTABILITY AND FITNESS FOR A PARTICULAR PURPOSE ARE DISCLAIMED. IN NO EVENT SHALL THE COPYRIGHT HOLDER OR CONTRIBUTORS BE LIABLE FOR ANY DIRECT, INDIRECT, INCIDENTAL, SPECIAL, EXEMPLARY, OR CONSEQUENTIAL DAMAGES (INCLUDING, BUT NOT LIMITED TO, PROCUREMENT OF SUBSTITUTE GOODS OR SERVICES; LOSS OF USE, DATA, OR PROFITS; OR BUSINESS INTERRUPTION)

HOWEVER CAUSED AND ON ANY THEORY OF LIABILITY, WHETHER IN CONTRACT, STRICT LIABILITY, OR TORT (INCLUDING NEGLIGENCE OR OTHERWISE) ARISING IN ANY WAY OUT OF THE USE OF THIS SOFTWARE, EVEN IF ADVISED OF THE POSSIBILITY OF SUCH DAMAGE.

{STM32CubeF4 Core}
©Copyright (c) 2017 STMicroelectronics. All rights reserved.
©Copyright (c) 2020 STMicroelectronics. All rights reserved.
©Copyright (c) 2021 STMicroelectronics. All rights reserved.
Copyright (c) 2022 STMicroelectronics. All rights reserved.

SLA0048 Rev4/March 2018

BY INSTALLING COPYING, DOWNLOADING, ACCESSING OR OTHERWISE USING THIS SOFTWARE PACKAGE OR ANY PART THEREOF (AND THE RELATED DOCUMENTATION) FROM STMICROELECTRONICS INTERNATIONAL N.V, SWISS BRANCH AND/OR ITS AFFILIATED COMPANIES (STMICROELECTRONICS), THE RECIPIENT, ON BEHALF OF HIMSELF OR HERSELF, OR ON BEHALF OF ANY ENTITY BY WHICH SUCH RECIPIENT IS EMPLOYED AND/OR ENGAGED AGREES TO BE BOUND BY THIS SOFTWARE PACKAGE LICENSE AGREEMENT.

Under STMicroelectronics' intellectual property rights and subject to applicable licensing terms for any third-party software incorporated in this software package and applicable Open Source Terms (as defined here below), the redistribution, reproduction and use in source and binary forms of the software package or any part thereof, with or without modification, are permitted provided that the following conditions are met:

1. Redistribution of source code (modified or not) must retain any copyright notice, this list of conditions and the following disclaimer.
2. Redistributions in binary form, except as embedded into microcontroller or microprocessor device manufactured by or for STMicroelectronics or a software update for such device, must reproduce the above copyright notice, this list of conditions and the following disclaimer in the documentation and/or other materials provided with the distribution.
3. Neither the name of STMicroelectronics nor the names of other contributors to this software package may be used to endorse or promote products derived from this software package or part thereof without specific written permission.
4. This software package or any part thereof, including modifications and/or derivative works of this software package, must be used and execute solely and exclusively on or in combination with a microcontroller or a microprocessor devices manufactured by or for STMicroelectronics.
5. No use, reproduction or redistribution of this software package partially or totally may be done in any manner that would subject this software package to any Open Source Terms (as defined below).
6. Some portion of the software package may contain software subject to Open Source Terms (as defined below) applicable for each such portion ("Open Source Software"), as further specified in the software package. Such Open Source Software is supplied under the applicable Open Source Terms and is not subject to the terms and conditions of license hereunder. "Open Source Terms" shall mean any open source license which requires as part of distribution of software that the source code of such software is distributed therewith or otherwise made available, or open source license that substantially complies with the Open Source definition specified at www.opensource.org and any other comparable open source license such as for example GNU General Public License (GPL), Eclipse Public License (EPL), Apache Software License, BSD license and MIT license.
7. This software package may also include third party software as expressly specified in the software package subject to specific license terms from such third parties. Such third party software is supplied under such specific license terms and is not subject to the terms and conditions of license hereunder. By installing copying, downloading, accessing or otherwise using this software package, the recipient agrees to be bound by such license terms with regard to such third party software.
8. STMicroelectronics has no obligation to provide any maintenance, support or updates for the software package.
9. The software package is and will remain the exclusive property of STMicroelectronics and its licensors. The recipient will not take any action that jeopardizes STMicroelectronics and its licensors' proprietary rights or acquire any rights in the software package, except the limited rights specified hereunder.
10. The recipient shall comply with all applicable laws and regulations affecting the use of the software package or any part thereof including any applicable

export control law or regulation.  
11. Redistribution and use of this software package partially or any part thereof other than as permitted under this license is void and will automatically terminate your rights under this license.

THIS SOFTWARE PACKAGE IS PROVIDED BY STMICROELECTRONICS AND CONTRIBUTORS "AS IS" AND ANY EXPRESS, IMPLIED OR STATUTORY WARRANTIES, INCLUDING, BUT NOT LIMITED TO, THE IMPLIED WARRANTIES OF MERCHANTABILITY, FITNESS FOR A PARTICULAR PURPOSE AND NON-INFRINGEMENT OF THIRD PARTY INTELLECTUAL PROPERTY RIGHTS ARE DISCLAIMED TO THE FULLEST EXTENT PERMITTED BY LAW. IN NO EVENT SHALL STMICROELECTRONICS OR CONTRIBUTORS BE LIABLE FOR ANY DIRECT, INDIRECT, INCIDENTAL, SPECIAL, EXEMPLARY, OR CONSEQUENTIAL DAMAGES (INCLUDING, BUT NOT LIMITED TO, PROCUREMENT OF SUBSTITUTE GOODS OR SERVICES; LOSS OF USE, DATA, OR PROFITS; OR BUSINESS INTERRUPTION) HOWEVER CAUSED AND ON ANY THEORY OF LIABILITY, WHETHER IN CONTRACT, STRICT LIABILITY, OR TORT (INCLUDING NEGLIGENCE OR OTHERWISE) ARISING IN ANY WAY OUT OF THE USE OF THIS SOFTWARE PACKAGE, EVEN IF ADVISED OF THE POSSIBILITY OF SUCH DAMAGE. EXCEPT AS EXPRESSLY PERMITTED HEREUNDER AND SUBJECT TO THE APPLICABLE LICENSING TERMS FOR ANY THIRD-PARTY SOFTWARE INCORPORATED IN THE SOFTWARE PACKAGE AND OPEN SOURCE TERMS AS APPLICABLE, NO LICENSE OR OTHER RIGHTS, WHETHER EXPRESS OR IMPLIED, ARE GRANTED UNDER ANY PATENT OR OTHER INTELLECTUAL PROPERTY RIGHTS OF STMICROELECTRONICS OR ANY THIRD PARTY.

{QR Code generator}  
Copyright (c) 2022 Project Nayuki.

Permission is hereby granted, free of charge, to any person obtaining a copy of this software and associated documentation files (the "Software"), to deal in the Software without restriction, including without limitation the rights to use, copy, modify, merge, publish, distribute, sublicense, and/or sell copies of the Software, and to permit persons to whom the Software is furnished to do so, subject to the following conditions:

The above copyright notice and this permission notice shall be included in all copies or substantial portions of the Software.

THE SOFTWARE IS PROVIDED "AS IS", WITHOUT WARRANTY OF ANY KIND, EXPRESS OR IMPLIED, INCLUDING BUT NOT LIMITED TO THE WARRANTIES OF MERCHANTABILITY, FITNESS FOR A PARTICULAR PURPOSE AND NON-INFRINGEMENT. IN NO EVENT SHALL THE AUTHORS OR COPYRIGHT HOLDERS BE LIABLE FOR ANY CLAIM, DAMAGES OR OTHER LIABILITY, WHETHER IN AN ACTION OF CONTRACT, TORT OR OTHERWISE, ARISING FROM, OUT OF OR IN CONNECTION WITH THE SOFTWARE OR THE USE OR OTHER DEALINGS IN THE SOFTWARE.

{newlib}  
The newlib subdirectory is a collection of software from several sources.

Each file may have its own copyright/license that is embedded in the source file. Unless otherwise noted in the body of the source file(s), the following copyright notices will apply to the contents of the newlib subdirectory:

(1) Red Hat Incorporated

Copyright (c) 1994-2009 Red Hat, Inc. All rights reserved.

This copyrighted material is made available to anyone wishing to use, modify, copy, or redistribute it subject to the terms and conditions of the BSD License. This program is distributed in the hope that it will be useful, but WITHOUT ANY WARRANTY expressed or implied, including the implied warranties of MERCHANTABILITY or FITNESS FOR A PARTICULAR PURPOSE. A copy of this license is available at <http://www.opensource.org/licenses>. Any Red Hat trademarks that are incorporated in the source code or documentation are not subject to the BSD License and may only be used or replicated with the express permission of Red Hat, Inc.

(2) University of California, Berkeley

Copyright (c) 1981-2000 The Regents of the University of California.  
All rights reserved.

Redistribution and use in source and binary forms, with or without modification, are permitted provided that the following conditions are met:

- \* Redistributions of source code must retain the above copyright notice, this list of conditions and the following disclaimer.
- \* Redistributions in binary form must reproduce the above copyright notice, this list of conditions and the following disclaimer in the documentation and/or other materials provided with the distribution.
- \* Neither the name of the University nor the names of its contributors may be used to endorse or promote products derived from this software without specific prior written permission.

THIS SOFTWARE IS PROVIDED BY THE COPYRIGHT HOLDERS AND CONTRIBUTORS "AS IS" AND ANY EXPRESS OR IMPLIED WARRANTIES, INCLUDING, BUT NOT LIMITED TO, THE IMPLIED WARRANTIES OF MERCHANTABILITY AND FITNESS FOR A PARTICULAR PURPOSE ARE DISCLAIMED. IN NO EVENT SHALL THE COPYRIGHT OWNER OR CONTRIBUTORS BE LIABLE FOR ANY DIRECT, INDIRECT, INCIDENTAL, SPECIAL, EXEMPLARY, OR CONSEQUENTIAL DAMAGES (INCLUDING, BUT NOT LIMITED TO, PROCUREMENT OF SUBSTITUTE GOODS OR SERVICES; LOSS OF USE, DATA, OR PROFITS; OR BUSINESS INTERRUPTION) HOWEVER CAUSED AND ON ANY THEORY OF LIABILITY, WHETHER IN CONTRACT, STRICT LIABILITY, OR TORT (INCLUDING NEGLIGENCE OR OTHERWISE) ARISING IN ANY WAY OUT OF THE USE OF THIS SOFTWARE, EVEN IF ADVISED OF THE POSSIBILITY OF SUCH DAMAGE.

(3) David M. Gay (AT&T 1991, Lucent 1998)

The author of this software is David M. Gay.

Copyright (c) 1991 by AT&T.

Permission to use, copy, modify, and distribute this software for any purpose without fee is hereby granted, provided that this entire notice is included in all copies of any software which is or includes a copy or modification of this software and in all copies of the supporting documentation for such software.

THIS SOFTWARE IS BEING PROVIDED "AS IS", WITHOUT ANY EXPRESS OR IMPLIED WARRANTY. IN PARTICULAR, NEITHER THE AUTHOR NOR AT&T MAKES ANY REPRESENTATION OR WARRANTY OF ANY KIND CONCERNING THE MERCHANTABILITY OF THIS SOFTWARE OR ITS FITNESS FOR ANY PARTICULAR PURPOSE.

-----  
The author of this software is David M. Gay.

Copyright (C) 1998-2001 by Lucent Technologies  
All Rights Reserved

Permission to use, copy, modify, and distribute this software and its documentation for any purpose and without fee is hereby granted, provided that the above copyright notice appear in all copies and that both that the copyright notice and this permission notice and warranty disclaimer appear in supporting documentation, and that the name of Lucent or any of its entities not be used in advertising or publicity pertaining to distribution of the software without specific, written prior permission.

LUCENT DISCLAIMS ALL WARRANTIES WITH REGARD TO THIS SOFTWARE, INCLUDING ALL IMPLIED WARRANTIES OF MERCHANTABILITY AND FITNESS. IN NO EVENT SHALL LUCENT OR ANY OF ITS ENTITIES BE LIABLE FOR ANY SPECIAL, INDIRECT OR CONSEQUENTIAL DAMAGES OR ANY DAMAGES WHATSOEVER RESULTING FROM LOSS OF USE, DATA OR PROFITS, WHETHER IN AN ACTION OF CONTRACT, NEGLIGENCE OR OTHER TORTIOUS ACTION, ARISING OUT OF OR IN CONNECTION WITH THE USE OR PERFORMANCE OF THIS SOFTWARE.

(4) Advanced Micro Devices

Copyright 1989, 1990 Advanced Micro Devices, Inc.

This software is the property of Advanced Micro Devices, Inc (AMD) which specifically grants the user the right to modify, use and distribute this software provided this notice is not removed or altered. All other rights are reserved by AMD.

# Copyrights, etc. (OSS) (Continued)

AMD MAKES NO WARRANTY OF ANY KIND, EXPRESS OR IMPLIED, WITH REGARD TO THIS SOFTWARE. IN NO EVENT SHALL AMD BE LIABLE FOR INCIDENTAL OR CONSEQUENTIAL DAMAGES IN CONNECTION WITH OR ARISING FROM THE FURNISHING, PERFORMANCE, OR USE OF THIS SOFTWARE.

So that all may benefit from your experience, please report any problems or suggestions about this software to the 29K Technical Support Center at 800-29-29-AMD (800-292-9263) in the USA, or 0800-89-1131 in the UK, or 0031-11-1129 in Japan, toll free. The direct dial number is 512-462-4118.

Advanced Micro Devices, Inc.  
29K Support Products  
Mail Stop 573  
5900 E. Ben White Blvd.  
Austin, TX 78741  
800-292-9263

(7) Sun Microsystems

Copyright (C) 1993 by Sun Microsystems, Inc. All rights reserved.

Developed at SunPro, a Sun Microsystems, Inc. business.  
Permission to use, copy, modify, and distribute this software is freely granted, provided that this notice is preserved.

(8) Hewlett Packard

(c) Copyright 1986 HEWLETT-PACKARD COMPANY

To anyone who acknowledges that this file is provided "AS IS" without any express or implied warranty:  
permission to use, copy, modify, and distribute this file for any purpose is hereby granted without fee, provided that the above copyright notice and this notice appears in all copies, and that the name of Hewlett-Packard Company not be used in advertising or publicity pertaining to distribution of the software without specific, written prior permission. Hewlett-Packard Company makes no representations about the suitability of this software for any purpose.

(9) Hans-Peter Nilsson

Copyright (C) 2001 Hans-Peter Nilsson

Permission to use, copy, modify, and distribute this software is freely granted, provided that the above copyright notice, this notice and the following disclaimer are preserved with no changes.

THIS SOFTWARE IS PROVIDED "AS IS" AND WITHOUT ANY EXPRESS OR IMPLIED WARRANTIES, INCLUDING, WITHOUT LIMITATION, THE IMPLIED WARRANTIES OF MERCHANTABILITY AND FITNESS FOR A PARTICULAR PURPOSE.

(11) Christopher G. Demetriou

Copyright (c) 2001 Christopher G. Demetriou  
All rights reserved.

Redistribution and use in source and binary forms, with or without modification, are permitted provided that the following conditions are met:

1. Redistributions of source code must retain the above copyright notice, this list of conditions and the following disclaimer.
2. Redistributions in binary form must reproduce the above copyright notice, this list of conditions and the following disclaimer in the documentation and/or other materials provided with the distribution.
3. The name of the author may not be used to endorse or promote products derived from this software without specific prior written permission.

THIS SOFTWARE IS PROVIDED BY THE AUTHOR "AS IS" AND ANY EXPRESS OR IMPLIED WARRANTIES, INCLUDING, BUT NOT LIMITED TO, THE IMPLIED WARRANTIES OF MERCHANTABILITY AND FITNESS FOR A PARTICULAR PURPOSE ARE DISCLAIMED. IN NO EVENT SHALL THE AUTHOR BE LIABLE FOR ANY DIRECT, INDIRECT, INCIDENTAL, SPECIAL, EXEMPLARY, OR CONSEQUENTIAL DAMAGES (INCLUDING, BUT NOT LIMITED TO, PROCUREMENT OF SUBSTITUTE GOODS OR SERVICES; LOSS OF USE, DATA, OR PROFITS; OR BUSINESS INTERRUPTION) HOWEVER CAUSED

AND ON ANY THEORY OF LIABILITY, WHETHER IN CONTRACT, STRICT LIABILITY, OR TORT (INCLUDING NEGLIGENCE OR OTHERWISE) ARISING IN ANY WAY OUT OF THE USE OF THIS SOFTWARE, EVEN IF ADVISED OF THE POSSIBILITY OF SUCH DAMAGE.

(12) SuperH, Inc.

Copyright 2002 SuperH, Inc. All rights reserved

This software is the property of SuperH, Inc (SuperH) which specifically grants the user the right to modify, use and distribute this software provided this notice is not removed or altered. All other rights are reserved by SuperH.

SUPERH MAKES NO WARRANTY OF ANY KIND, EXPRESS OR IMPLIED, WITH REGARD TO THIS SOFTWARE. IN NO EVENT SHALL SUPERH BE LIABLE FOR INDIRECT, SPECIAL, INCIDENTAL OR CONSEQUENTIAL DAMAGES IN CONNECTION WITH OR ARISING FROM THE FURNISHING, PERFORMANCE, OR USE OF THIS SOFTWARE.

So that all may benefit from your experience, please report any problems or suggestions about this software to the SuperH Support Center via e-mail at [softwaresupport@superh.com](mailto:softwaresupport@superh.com).

SuperH, Inc.  
405 River Oaks Parkway  
San Jose  
CA 95134  
USA

(13) Royal Institute of Technology

Copyright (c) 1999 Kungliga Tekniska Högskolan  
(Royal Institute of Technology, Stockholm, Sweden).  
All rights reserved.

Redistribution and use in source and binary forms, with or without modification, are permitted provided that the following conditions are met:

1. Redistributions of source code must retain the above copyright notice, this list of conditions and the following disclaimer.
2. Redistributions in binary form must reproduce the above copyright notice, this list of conditions and the following disclaimer in the documentation and/or other materials provided with the distribution.
3. Neither the name of KTH nor the names of its contributors may be used to endorse or promote products derived from this software without specific prior written permission.

THIS SOFTWARE IS PROVIDED BY KTH AND ITS CONTRIBUTORS "AS IS" AND ANY EXPRESS OR IMPLIED WARRANTIES, INCLUDING, BUT NOT LIMITED TO, THE IMPLIED WARRANTIES OF MERCHANTABILITY AND FITNESS FOR A PARTICULAR PURPOSE ARE DISCLAIMED. IN NO EVENT SHALL KTH OR ITS CONTRIBUTORS BE LIABLE FOR ANY DIRECT, INDIRECT, INCIDENTAL, SPECIAL, EXEMPLARY, OR CONSEQUENTIAL DAMAGES (INCLUDING, BUT NOT LIMITED TO, PROCUREMENT OF SUBSTITUTE GOODS OR SERVICES; LOSS OF USE, DATA, OR PROFITS; OR BUSINESS INTERRUPTION) HOWEVER CAUSED AND ON ANY THEORY OF LIABILITY, WHETHER IN CONTRACT, STRICT LIABILITY, OR TORT (INCLUDING NEGLIGENCE OR OTHERWISE) ARISING IN ANY WAY OUT OF THE USE OF THIS SOFTWARE, EVEN IF ADVISED OF THE POSSIBILITY OF SUCH DAMAGE.

(14) Alexey Zelkin

Copyright (c) 2000, 2001 Alexey Zelkin <[phantom@FreeBSD.org](mailto:phantom@FreeBSD.org)>  
All rights reserved.

Redistribution and use in source and binary forms, with or without modification, are permitted provided that the following conditions are met:

1. Redistributions of source code must retain the above copyright notice, this list of conditions and the following disclaimer.
2. Redistributions in binary form must reproduce the above copyright notice, this list of conditions and the following disclaimer in the documentation and/or other materials provided with the distribution.

THIS SOFTWARE IS PROVIDED BY THE AUTHOR AND CONTRIBUTORS "AS IS" AND ANY EXPRESS OR IMPLIED WARRANTIES, INCLUDING, BUT NOT LIMITED TO, THE IMPLIED WARRANTIES OF MERCHANTABILITY AND FITNESS FOR A PARTICULAR PURPOSE ARE DISCLAIMED. IN NO EVENT SHALL THE AUTHOR OR CONTRIBUTORS BE LIABLE FOR ANY DIRECT, INDIRECT, INCIDENTAL, SPECIAL, EXEMPLARY, OR CONSEQUENTIAL DAMAGES (INCLUDING, BUT NOT LIMITED TO, PROCUREMENT OF SUBSTITUTE GOODS OR SERVICES; LOSS OF USE, DATA, OR PROFITS; OR BUSINESS INTERRUPTION) HOWEVER CAUSED AND ON ANY THEORY OF LIABILITY, WHETHER IN CONTRACT, STRICT LIABILITY, OR TORT (INCLUDING NEGLIGENCE OR OTHERWISE) ARISING IN ANY WAY OUT OF THE USE OF THIS SOFTWARE, EVEN IF ADVISED OF THE POSSIBILITY OF SUCH DAMAGE.

(15) Andrey A. Chernov

Copyright (C) 1997 by Andrey A. Chernov, Moscow, Russia.  
All rights reserved.

Redistribution and use in source and binary forms, with or without modification, are permitted provided that the following conditions are met:

1. Redistributions of source code must retain the above copyright notice, this list of conditions and the following disclaimer.
2. Redistributions in binary form must reproduce the above copyright notice, this list of conditions and the following disclaimer in the documentation and/or other materials provided with the distribution.

THIS SOFTWARE IS PROVIDED BY THE AUTHOR "AS IS" AND ANY EXPRESS OR IMPLIED WARRANTIES, INCLUDING, BUT NOT LIMITED TO, THE IMPLIED WARRANTIES OF MERCHANTABILITY AND FITNESS FOR A PARTICULAR PURPOSE ARE DISCLAIMED. IN NO EVENT SHALL THE REGENTS OR CONTRIBUTORS BE LIABLE FOR ANY DIRECT, INDIRECT, INCIDENTAL, SPECIAL, EXEMPLARY, OR CONSEQUENTIAL DAMAGES (INCLUDING, BUT NOT LIMITED TO, PROCUREMENT OF SUBSTITUTE GOODS OR SERVICES; LOSS OF USE, DATA, OR PROFITS; OR BUSINESS INTERRUPTION) HOWEVER CAUSED AND ON ANY THEORY OF LIABILITY, WHETHER IN CONTRACT, STRICT LIABILITY, OR TORT (INCLUDING NEGLIGENCE OR OTHERWISE) ARISING IN ANY WAY OUT OF THE USE OF THIS SOFTWARE, EVEN IF ADVISED OF THE POSSIBILITY OF SUCH DAMAGE.

(16) FreeBSD

Copyright (c) 1997-2002 FreeBSD Project.  
All rights reserved.

Redistribution and use in source and binary forms, with or without modification, are permitted provided that the following conditions are met:

1. Redistributions of source code must retain the above copyright notice, this list of conditions and the following disclaimer.
2. Redistributions in binary form must reproduce the above copyright notice, this list of conditions and the following disclaimer in the documentation and/or other materials provided with the distribution.

THIS SOFTWARE IS PROVIDED BY THE AUTHOR AND CONTRIBUTORS "AS IS" AND ANY EXPRESS OR IMPLIED WARRANTIES, INCLUDING, BUT NOT LIMITED TO, THE IMPLIED WARRANTIES OF MERCHANTABILITY AND FITNESS FOR A PARTICULAR PURPOSE ARE DISCLAIMED. IN NO EVENT SHALL THE AUTHOR OR CONTRIBUTORS BE LIABLE FOR ANY DIRECT, INDIRECT, INCIDENTAL, SPECIAL, EXEMPLARY, OR CONSEQUENTIAL DAMAGES (INCLUDING, BUT NOT LIMITED TO, PROCUREMENT OF SUBSTITUTE GOODS OR SERVICES; LOSS OF USE, DATA, OR PROFITS; OR BUSINESS INTERRUPTION) HOWEVER CAUSED AND ON ANY THEORY OF LIABILITY, WHETHER IN CONTRACT, STRICT LIABILITY, OR TORT (INCLUDING NEGLIGENCE OR OTHERWISE) ARISING IN ANY WAY OUT OF THE USE OF THIS SOFTWARE, EVEN IF ADVISED OF THE POSSIBILITY OF SUCH DAMAGE.

(17) S. L. Moshier

Author: S. L. Moshier.

Copyright (c) 1984,2000 S.L. Moshier

Permission to use, copy, modify, and distribute this software for any purpose without fee is hereby granted, provided that this entire notice is included in all

copies of any software which is or includes a copy or modification of this software and in all copies of the supporting documentation for such software.

THIS SOFTWARE IS BEING PROVIDED "AS IS", WITHOUT ANY EXPRESS OR IMPLIED WARRANTY. IN PARTICULAR, THE AUTHOR MAKES NO REPRESENTATION OR WARRANTY OF ANY KIND CONCERNING THE MERCHANTABILITY OF THIS SOFTWARE OR ITS FITNESS FOR ANY PARTICULAR PURPOSE.

(18) Citrus Project

Copyright (c)1999 Citrus Project,  
All rights reserved.

Redistribution and use in source and binary forms, with or without modification, are permitted provided that the following conditions are met:

1. Redistributions of source code must retain the above copyright notice, this list of conditions and the following disclaimer.
2. Redistributions in binary form must reproduce the above copyright notice, this list of conditions and the following disclaimer in the documentation and/or other materials provided with the distribution.

THIS SOFTWARE IS PROVIDED BY THE AUTHOR AND CONTRIBUTORS "AS IS" AND ANY EXPRESS OR IMPLIED WARRANTIES, INCLUDING, BUT NOT LIMITED TO, THE IMPLIED WARRANTIES OF MERCHANTABILITY AND FITNESS FOR A PARTICULAR PURPOSE ARE DISCLAIMED. IN NO EVENT SHALL THE AUTHOR OR CONTRIBUTORS BE LIABLE FOR ANY DIRECT, INDIRECT, INCIDENTAL, SPECIAL, EXEMPLARY, OR CONSEQUENTIAL DAMAGES (INCLUDING, BUT NOT LIMITED TO, PROCUREMENT OF SUBSTITUTE GOODS OR SERVICES; LOSS OF USE, DATA, OR PROFITS; OR BUSINESS INTERRUPTION) HOWEVER CAUSED AND ON ANY THEORY OF LIABILITY, WHETHER IN CONTRACT, STRICT LIABILITY, OR TORT (INCLUDING NEGLIGENCE OR OTHERWISE) ARISING IN ANY WAY OUT OF THE USE OF THIS SOFTWARE, EVEN IF ADVISED OF THE POSSIBILITY OF SUCH DAMAGE.

(19) Todd C. Miller

Copyright (c) 1998 Todd C. Miller <Todd.Miller@courtesan.com>  
All rights reserved.

Redistribution and use in source and binary forms, with or without modification, are permitted provided that the following conditions are met:

1. Redistributions of source code must retain the above copyright notice, this list of conditions and the following disclaimer.
2. Redistributions in binary form must reproduce the above copyright notice, this list of conditions and the following disclaimer in the documentation and/or other materials provided with the distribution.
3. The name of the author may not be used to endorse or promote products derived from this software without specific prior written permission.

THIS SOFTWARE IS PROVIDED "AS IS" AND ANY EXPRESS OR IMPLIED WARRANTIES, INCLUDING, BUT NOT LIMITED TO, THE IMPLIED WARRANTIES OF MERCHANTABILITY AND FITNESS FOR A PARTICULAR PURPOSE ARE DISCLAIMED. IN NO EVENT SHALL THE AUTHOR BE LIABLE FOR ANY DIRECT, INDIRECT, INCIDENTAL, SPECIAL, EXEMPLARY, OR CONSEQUENTIAL DAMAGES (INCLUDING, BUT NOT LIMITED TO, PROCUREMENT OF SUBSTITUTE GOODS OR SERVICES; LOSS OF USE, DATA, OR PROFITS; OR BUSINESS INTERRUPTION) HOWEVER CAUSED AND ON ANY THEORY OF LIABILITY, WHETHER IN CONTRACT, STRICT LIABILITY, OR TORT (INCLUDING NEGLIGENCE OR OTHERWISE) ARISING IN ANY WAY OUT OF THE USE OF THIS SOFTWARE, EVEN IF ADVISED OF THE POSSIBILITY OF SUCH DAMAGE.

(20) DJ Delorie (i386)

Copyright (C) 1991 DJ Delorie  
All rights reserved.

Redistribution, modification, and use in source and binary forms is permitted provided that the above copyright notice and following paragraph are duplicated in all such forms.

This file is distributed WITHOUT ANY WARRANTY; without even the implied warranty of MERCHANTABILITY or FITNESS FOR A PARTICULAR PURPOSE.

# Copyrights, etc. (OSS) (Continued)

(23) Intel (i960)

Copyright (c) 1993 Intel Corporation

Intel hereby grants you permission to copy, modify, and distribute this software and its documentation. Intel grants this permission provided that the above copyright notice appears in all copies and that both the copyright notice and this permission notice appear in supporting documentation. In addition, Intel grants this permission provided that you prominently mark as "not part of the original" any modifications made to this software or documentation, and that the name of Intel Corporation not be used in advertising or publicity pertaining to distribution of the software or the documentation without specific, written prior permission.

Intel Corporation provides this AS IS, WITHOUT ANY WARRANTY, EXPRESS OR IMPLIED, INCLUDING, WITHOUT LIMITATION, ANY WARRANTY OF MERCHANTABILITY OR FITNESS FOR A PARTICULAR PURPOSE. Intel makes no guarantee or representations regarding the use of, or the results of the use of, the software and documentation in terms of correctness, accuracy, reliability, currentness, or otherwise; and you rely on the software, documentation and results solely at your own risk.

IN NO EVENT SHALL INTEL BE LIABLE FOR ANY LOSS OF USE, LOSS OF BUSINESS, LOSS OF PROFITS, INDIRECT, INCIDENTAL, SPECIAL OR CONSEQUENTIAL DAMAGES OF ANY KIND. IN NO EVENT SHALL INTEL'S TOTAL LIABILITY EXCEED THE SUM PAID TO INTEL FOR THE PRODUCT LICENSED HEREUNDER.

(26) Mike Barcroft

Copyright (c) 2001 Mike Barcroft <mike@FreeBSD.org>  
All rights reserved.

Redistribution and use in source and binary forms, with or without modification, are permitted provided that the following conditions are met:

1. Redistributions of source code must retain the above copyright notice, this list of conditions and the following disclaimer.
2. Redistributions in binary form must reproduce the above copyright notice, this list of conditions and the following disclaimer in the documentation and/or other materials provided with the distribution.

THIS SOFTWARE IS PROVIDED BY THE AUTHOR AND CONTRIBUTORS "AS IS" AND ANY EXPRESS OR IMPLIED WARRANTIES, INCLUDING, BUT NOT LIMITED TO, THE IMPLIED WARRANTIES OF MERCHANTABILITY AND FITNESS FOR A PARTICULAR PURPOSE ARE DISCLAIMED. IN NO EVENT SHALL THE AUTHOR OR CONTRIBUTORS BE LIABLE FOR ANY DIRECT, INDIRECT, INCIDENTAL, SPECIAL, EXEMPLARY, OR CONSEQUENTIAL DAMAGES (INCLUDING, BUT NOT LIMITED TO, PROCUREMENT OF SUBSTITUTE GOODS OR SERVICES; LOSS OF USE, DATA, OR PROFITS; OR BUSINESS INTERRUPTION) HOWEVER CAUSED AND ON ANY THEORY OF LIABILITY, WHETHER IN CONTRACT, STRICT LIABILITY, OR TORT (INCLUDING NEGLIGENCE OR OTHERWISE) ARISING IN ANY WAY OUT OF THE USE OF THIS SOFTWARE, EVEN IF ADVISED OF THE POSSIBILITY OF SUCH DAMAGE.

(27) Konstantin Chuguev (--enable-newlib-iconv)

Copyright (c) 1999, 2000  
Konstantin Chuguev. All rights reserved.

Redistribution and use in source and binary forms, with or without modification, are permitted provided that the following conditions are met:

1. Redistributions of source code must retain the above copyright notice, this list of conditions and the following disclaimer.
2. Redistributions in binary form must reproduce the above copyright notice, this list of conditions and the following disclaimer in the documentation and/or other materials provided with the distribution.

THIS SOFTWARE IS PROVIDED BY THE AUTHOR AND CONTRIBUTORS "AS IS" AND ANY EXPRESS OR IMPLIED WARRANTIES, INCLUDING, BUT NOT LIMITED TO, THE IMPLIED WARRANTIES OF MERCHANTABILITY AND FITNESS FOR A PARTICULAR PURPOSE ARE DISCLAIMED. IN NO EVENT SHALL THE AUTHOR OR CONTRIBUTORS BE LIABLE FOR ANY DIRECT, INDIRECT, INCIDENTAL, SPECIAL, EXEMPLARY, OR CONSEQUENTIAL DAMAGES (INCLUDING, BUT NOT LIMITED TO, PROCUREMENT OF SUBSTITUTE GOODS OR SERVICES; LOSS OF USE, DATA, OR PROFITS; OR BUSINESS INTERRUPTION) HOWEVER CAUSED AND ON ANY THEORY

OF LIABILITY, WHETHER IN CONTRACT, STRICT LIABILITY, OR TORT (INCLUDING NEGLIGENCE OR OTHERWISE) ARISING IN ANY WAY OUT OF THE USE OF THIS SOFTWARE, EVEN IF ADVISED OF THE POSSIBILITY OF SUCH DAMAGE.

iconv (Charset Conversion Library) v2.0

(28) Artem Bityuckiy (--enable-newlib-iconv)

Copyright (c) 2003, Artem B. Bityuckiy, SoftMine Corporation.  
Rights transferred to Franklin Electronic Publishers.

Redistribution and use in source and binary forms, with or without modification, are permitted provided that the following conditions are met:

1. Redistributions of source code must retain the above copyright notice, this list of conditions and the following disclaimer.
2. Redistributions in binary form must reproduce the above copyright notice, this list of conditions and the following disclaimer in the documentation and/or other materials provided with the distribution.

THIS SOFTWARE IS PROVIDED BY THE AUTHOR AND CONTRIBUTORS "AS IS" AND ANY EXPRESS OR IMPLIED WARRANTIES, INCLUDING, BUT NOT LIMITED TO, THE IMPLIED WARRANTIES OF MERCHANTABILITY AND FITNESS FOR A PARTICULAR PURPOSE ARE DISCLAIMED. IN NO EVENT SHALL THE AUTHOR OR CONTRIBUTORS BE LIABLE FOR ANY DIRECT, INDIRECT, INCIDENTAL, SPECIAL, EXEMPLARY, OR CONSEQUENTIAL DAMAGES (INCLUDING, BUT NOT LIMITED TO, PROCUREMENT OF SUBSTITUTE GOODS OR SERVICES; LOSS OF USE, DATA, OR PROFITS; OR BUSINESS INTERRUPTION) HOWEVER CAUSED AND ON ANY THEORY OF LIABILITY, WHETHER IN CONTRACT, STRICT LIABILITY, OR TORT (INCLUDING NEGLIGENCE OR OTHERWISE) ARISING IN ANY WAY OUT OF THE USE OF THIS SOFTWARE, EVEN IF ADVISED OF THE POSSIBILITY OF SUCH DAMAGE.

(30) - Alex Tatmanjants (targets using libc/posix)

Copyright (c) 1995 Alex Tatmanjants <alex@elvisti.kiev.ua>  
at Electronni Visti IA, Kiev, Ukraine.  
All rights reserved.

Redistribution and use in source and binary forms, with or without modification, are permitted provided that the following conditions are met:

1. Redistributions of source code must retain the above copyright notice, this list of conditions and the following disclaimer.
2. Redistributions in binary form must reproduce the above copyright notice, this list of conditions and the following disclaimer in the documentation and/or other materials provided with the distribution.

THIS SOFTWARE IS PROVIDED BY THE AUTHOR "AS IS" AND ANY EXPRESS OR IMPLIED WARRANTIES, INCLUDING, BUT NOT LIMITED TO, THE IMPLIED WARRANTIES OF MERCHANTABILITY AND FITNESS FOR A PARTICULAR PURPOSE ARE DISCLAIMED. IN NO EVENT SHALL THE AUTHOR BE LIABLE FOR ANY DIRECT, INDIRECT, INCIDENTAL, SPECIAL, EXEMPLARY, OR CONSEQUENTIAL DAMAGES (INCLUDING, BUT NOT LIMITED TO, PROCUREMENT OF SUBSTITUTE GOODS OR SERVICES; LOSS OF USE, DATA, OR PROFITS; OR BUSINESS INTERRUPTION) HOWEVER CAUSED AND ON ANY THEORY OF LIABILITY, WHETHER IN CONTRACT, STRICT LIABILITY, OR TORT (INCLUDING NEGLIGENCE OR OTHERWISE) ARISING IN ANY WAY OUT OF THE USE OF THIS SOFTWARE, EVEN IF ADVISED OF THE POSSIBILITY OF SUCH DAMAGE.

(31) - M. Warner Losh (targets using libc/posix)

Copyright (c) 1998, M. Warner Losh <imp@freebsd.org>  
All rights reserved.

Redistribution and use in source and binary forms, with or without modification, are permitted provided that the following conditions are met:

1. Redistributions of source code must retain the above copyright notice, this list of conditions and the following disclaimer.
2. Redistributions in binary form must reproduce the above copyright notice, this list of conditions and the following disclaimer in the documentation and/or other materials provided with the distribution.

THIS SOFTWARE IS PROVIDED BY THE AUTHOR AND CONTRIBUTORS "AS IS" AND ANY EXPRESS OR IMPLIED WARRANTIES, INCLUDING, BUT

NOT LIMITED TO, THE IMPLIED WARRANTIES OF MERCHANTABILITY AND FITNESS FOR A PARTICULAR PURPOSE ARE DISCLAIMED. IN NO EVENT SHALL THE AUTHOR OR CONTRIBUTORS BE LIABLE FOR ANY DIRECT, INDIRECT, INCIDENTAL, SPECIAL, EXEMPLARY, OR CONSEQUENTIAL DAMAGES (INCLUDING, BUT NOT LIMITED TO, PROCUREMENT OF SUBSTITUTE GOODS OR SERVICES; LOSS OF USE, DATA, OR PROFITS; OR BUSINESS INTERRUPTION) HOWEVER CAUSED AND ON ANY THEORY OF LIABILITY, WHETHER IN CONTRACT, STRICT LIABILITY, OR TORT (INCLUDING NEGLIGENCE OR OTHERWISE) ARISING IN ANY WAY OUT OF THE USE OF THIS SOFTWARE, EVEN IF ADVISED OF THE POSSIBILITY OF SUCH DAMAGE.

(32) - Andrey A. Chernov (targets using libc/posix)

Copyright (C) 1996 by Andrey A. Chernov, Moscow, Russia.  
All rights reserved.

Redistribution and use in source and binary forms, with or without modification, are permitted provided that the following conditions are met:

1. Redistributions of source code must retain the above copyright notice, this list of conditions and the following disclaimer.
2. Redistributions in binary form must reproduce the above copyright notice, this list of conditions and the following disclaimer in the documentation and/or other materials provided with the distribution.

THIS SOFTWARE IS PROVIDED BY THE AUTHOR "AS IS" AND ANY EXPRESS OR IMPLIED WARRANTIES, INCLUDING, BUT NOT LIMITED TO, THE IMPLIED WARRANTIES OF MERCHANTABILITY AND FITNESS FOR A PARTICULAR PURPOSE ARE DISCLAIMED. IN NO EVENT SHALL THE REGENTS OR CONTRIBUTORS BE LIABLE FOR ANY DIRECT, INDIRECT, INCIDENTAL, SPECIAL, EXEMPLARY, OR CONSEQUENTIAL DAMAGES (INCLUDING, BUT NOT LIMITED TO, PROCUREMENT OF SUBSTITUTE GOODS OR SERVICES; LOSS OF USE, DATA, OR PROFITS; OR BUSINESS INTERRUPTION) HOWEVER CAUSED AND ON ANY THEORY OF LIABILITY, WHETHER IN CONTRACT, STRICT LIABILITY, OR TORT (INCLUDING NEGLIGENCE OR OTHERWISE) ARISING IN ANY WAY OUT OF THE USE OF THIS SOFTWARE, EVEN IF ADVISED OF THE POSSIBILITY OF SUCH DAMAGE.

(33) - Daniel Eischen (targets using libc/posix)

Copyright (c) 2001 Daniel Eischen <deischen@FreeBSD.org>.  
All rights reserved.

Redistribution and use in source and binary forms, with or without modification, are permitted provided that the following conditions are met:

1. Redistributions of source code must retain the above copyright notice, this list of conditions and the following disclaimer.
2. Redistributions in binary form must reproduce the above copyright notice, this list of conditions and the following disclaimer in the documentation and/or other materials provided with the distribution.

THIS SOFTWARE IS PROVIDED BY THE AUTHOR AND CONTRIBUTORS "AS IS" AND ANY EXPRESS OR IMPLIED WARRANTIES, INCLUDING, BUT NOT LIMITED TO, THE IMPLIED WARRANTIES OF MERCHANTABILITY AND FITNESS FOR A PARTICULAR PURPOSE ARE DISCLAIMED. IN NO EVENT SHALL THE REGENTS OR CONTRIBUTORS BE LIABLE FOR ANY DIRECT, INDIRECT, INCIDENTAL, SPECIAL, EXEMPLARY, OR CONSEQUENTIAL DAMAGES (INCLUDING, BUT NOT LIMITED TO, PROCUREMENT OF SUBSTITUTE GOODS OR SERVICES; LOSS OF USE, DATA, OR PROFITS; OR BUSINESS INTERRUPTION) HOWEVER CAUSED AND ON ANY THEORY OF LIABILITY, WHETHER IN CONTRACT, STRICT LIABILITY, OR TORT (INCLUDING NEGLIGENCE OR OTHERWISE) ARISING IN ANY WAY OUT OF THE USE OF THIS SOFTWARE, EVEN IF ADVISED OF THE POSSIBILITY OF SUCH DAMAGE.

(35) - ARM Ltd (arm and thumb variant targets only)

Copyright (c) 2009-2015 ARM Ltd  
All rights reserved.

Redistribution and use in source and binary forms, with or without modification, are permitted provided that the following conditions are met:

1. Redistributions of source code must retain the above copyright notice, this list of conditions and the following disclaimer.
2. Redistributions in binary form must reproduce the above copyright notice, this

list of conditions and the following disclaimer in the documentation and/or other materials provided with the distribution.

3. The name of the company may not be used to endorse or promote products derived from this software without specific prior written permission.

THIS SOFTWARE IS PROVIDED BY ARM LTD "AS IS" AND ANY EXPRESS OR IMPLIED WARRANTIES, INCLUDING, BUT NOT LIMITED TO, THE IMPLIED WARRANTIES OF MERCHANTABILITY AND FITNESS FOR A PARTICULAR PURPOSE ARE DISCLAIMED. IN NO EVENT SHALL ARM LTD BE LIABLE FOR ANY DIRECT, INDIRECT, INCIDENTAL, SPECIAL, EXEMPLARY, OR CONSEQUENTIAL DAMAGES (INCLUDING, BUT NOT LIMITED TO, PROCUREMENT OF SUBSTITUTE GOODS OR SERVICES; LOSS OF USE, DATA, OR PROFITS; OR BUSINESS INTERRUPTION) HOWEVER CAUSED AND ON ANY THEORY OF LIABILITY, WHETHER IN CONTRACT, STRICT LIABILITY, OR TORT (INCLUDING NEGLIGENCE OR OTHERWISE) ARISING IN ANY WAY OUT OF THE USE OF THIS SOFTWARE, EVEN IF ADVISED OF THE POSSIBILITY OF SUCH DAMAGE.

(41) Ed Schouten - Free BSD

Copyright (c) 2008 Ed Schouten <ed@FreeBSD.org>  
All rights reserved.

Redistribution and use in source and binary forms, with or without modification, are permitted provided that the following conditions are met:

1. Redistributions of source code must retain the above copyright notice, this list of conditions and the following disclaimer.
2. Redistributions in binary form must reproduce the above copyright notice, this list of conditions and the following disclaimer in the documentation and/or other materials provided with the distribution.

THIS SOFTWARE IS PROVIDED BY THE AUTHOR AND CONTRIBUTORS "AS IS" AND ANY EXPRESS OR IMPLIED WARRANTIES, INCLUDING, BUT NOT LIMITED TO, THE IMPLIED WARRANTIES OF MERCHANTABILITY AND FITNESS FOR A PARTICULAR PURPOSE ARE DISCLAIMED. IN NO EVENT SHALL THE AUTHOR OR CONTRIBUTORS BE LIABLE FOR ANY DIRECT, INDIRECT, INCIDENTAL, SPECIAL, EXEMPLARY, OR CONSEQUENTIAL DAMAGES (INCLUDING, BUT NOT LIMITED TO, PROCUREMENT OF SUBSTITUTE GOODS OR SERVICES; LOSS OF USE, DATA, OR PROFITS; OR BUSINESS INTERRUPTION) HOWEVER CAUSED AND ON ANY THEORY OF LIABILITY, WHETHER IN CONTRACT, STRICT LIABILITY, OR TORT (INCLUDING NEGLIGENCE OR OTHERWISE) ARISING IN ANY WAY OUT OF THE USE OF THIS SOFTWARE, EVEN IF ADVISED OF THE POSSIBILITY OF SUCH DAMAGE.

(46)

Copyright (c) 2016, Synopsys, Inc. All rights reserved.

Redistribution and use in source and binary forms, with or without modification, are permitted provided that the following conditions are met:

- 1) Redistributions of source code must retain the above copyright notice, this list of conditions and the following disclaimer.
- 2) Redistributions in binary form must reproduce the above copyright notice, this list of conditions and the following disclaimer in the documentation and/or other materials provided with the distribution.
- 3) Neither the name of the Synopsys, Inc., nor the names of its contributors may be used to endorse or promote products derived from this software without specific prior written permission.

THIS SOFTWARE IS PROVIDED BY THE COPYRIGHT HOLDERS AND CONTRIBUTORS "AS IS" AND ANY EXPRESS OR IMPLIED WARRANTIES, INCLUDING, BUT NOT LIMITED TO, THE IMPLIED WARRANTIES OF MERCHANTABILITY AND FITNESS FOR A PARTICULAR PURPOSE ARE DISCLAIMED. IN NO EVENT SHALL THE COPYRIGHT HOLDER OR CONTRIBUTORS BE LIABLE FOR ANY DIRECT, INDIRECT, INCIDENTAL, SPECIAL, EXEMPLARY, OR CONSEQUENTIAL DAMAGES (INCLUDING, BUT NOT LIMITED TO, PROCUREMENT OF SUBSTITUTE GOODS OR SERVICES; LOSS OF USE, DATA, OR PROFITS; OR BUSINESS INTERRUPTION) HOWEVER CAUSED AND ON ANY THEORY OF LIABILITY, WHETHER IN CONTRACT, STRICT LIABILITY, OR TORT (INCLUDING NEGLIGENCE OR OTHERWISE) ARISING IN ANY WAY OUT OF THE USE OF THIS SOFTWARE, EVEN IF ADVISED OF THE POSSIBILITY OF SUCH DAMAGE.

# Copyrights, etc. (OSS) (Continued)

(47)

Copyright (c) 2016 Joel Sherrill <joel@rtems.org>. All rights reserved.

Redistribution and use in source and binary forms, with or without modification, are permitted provided that the following conditions are met:

1. Redistributions of source code must retain the above copyright notice, this list of conditions and the following disclaimer.
2. Redistributions in binary form must reproduce the above copyright notice, this list of conditions and the following disclaimer in the documentation and/or other materials provided with the distribution.

THIS SOFTWARE IS PROVIDED BY THE AUTHOR AND CONTRIBUTORS "AS IS" AND ANY EXPRESS OR IMPLIED WARRANTIES, INCLUDING, BUT NOT LIMITED TO, THE IMPLIED WARRANTIES OF MERCHANTABILITY AND FITNESS FOR A PARTICULAR PURPOSE ARE DISCLAIMED. IN NO EVENT SHALL THE AUTHOR OR CONTRIBUTORS BE LIABLE FOR ANY DIRECT, INDIRECT, INCIDENTAL, SPECIAL, EXEMPLARY, OR CONSEQUENTIAL DAMAGES (INCLUDING, BUT NOT LIMITED TO, PROCUREMENT OF SUBSTITUTE GOODS OR SERVICES; LOSS OF USE, DATA, OR PROFITS; OR BUSINESS INTERRUPTION) HOWEVER CAUSED AND ON ANY THEORY OF LIABILITY, WHETHER IN CONTRACT, STRICT LIABILITY, OR TORT (INCLUDING NEGLIGENCE OR OTHERWISE) ARISING IN ANY WAY OUT OF THE USE OF THIS SOFTWARE, EVEN IF ADVISED OF THE POSSIBILITY OF SUCH DAMAGE.

(48)

From musl include/elf.h

Copyright © 2005-2014 Rich Felker, et al.

Permission is hereby granted, free of charge, to any person obtaining a copy of this software and associated documentation files (the "Software"), to deal in the Software without restriction, including without limitation the rights to use, copy, modify, merge, publish, distribute, sublicense, and/or sell copies of the Software, and to permit persons to whom the Software is furnished to do so, subject to the following conditions:

The above copyright notice and this permission notice shall be included in all copies or substantial portions of the Software.

THE SOFTWARE IS PROVIDED "AS IS", WITHOUT WARRANTY OF ANY KIND, EXPRESS OR IMPLIED, INCLUDING BUT NOT LIMITED TO THE WARRANTIES OF MERCHANTABILITY, FITNESS FOR A PARTICULAR PURPOSE AND NONINFRINGEMENT. IN NO EVENT SHALL THE AUTHORS OR COPYRIGHT HOLDERS BE LIABLE FOR ANY CLAIM, DAMAGES OR OTHER LIABILITY, WHETHER IN AN ACTION OF CONTRACT, TORT OR OTHERWISE, ARISING FROM, OUT OF OR IN CONNECTION WITH THE SOFTWARE OR THE USE OR OTHER DEALINGS IN THE SOFTWARE.

(49)

Copyright (c) 2008 Otto Moerbeek <otto@drijf.net>

Permission to use, copy, modify, and distribute this software for any purpose with or without fee is hereby granted, provided that the above copyright notice and this permission notice appear in all copies.

THE SOFTWARE IS PROVIDED "AS IS" AND THE AUTHOR DISCLAIMS ALL WARRANTIES WITH REGARD TO THIS SOFTWARE INCLUDING ALL IMPLIED WARRANTIES OF MERCHANTABILITY AND FITNESS. IN NO EVENT SHALL THE AUTHOR BE LIABLE FOR ANY SPECIAL, DIRECT, INDIRECT, OR CONSEQUENTIAL DAMAGES OR ANY DAMAGES WHATSOEVER RESULTING FROM LOSS OF USE, DATA OR PROFITS, WHETHER IN AN ACTION OF CONTRACT, NEGLIGENCE OR OTHER TORTIOUS ACTION, ARISING OUT OF OR IN CONNECTION WITH THE USE OR PERFORMANCE OF THIS SOFTWARE.

(50)

Copyright (c) 2017 embedded brains GmbH  
All rights reserved.

Redistribution and use in source and binary forms, with or without modification, are permitted provided that the following conditions are met:

1. Redistributions of source code must retain the above copyright notice, this list

of conditions and the following disclaimer.

2. Redistributions in binary form must reproduce the above copyright notice, this list of conditions and the following disclaimer in the documentation and/or other materials provided with the distribution.

THIS SOFTWARE IS PROVIDED BY THE AUTHOR AND CONTRIBUTORS "AS IS" AND ANY EXPRESS OR IMPLIED WARRANTIES, INCLUDING, BUT NOT LIMITED TO, THE IMPLIED WARRANTIES OF MERCHANTABILITY AND FITNESS FOR A PARTICULAR PURPOSE ARE DISCLAIMED. IN NO EVENT SHALL THE AUTHOR OR CONTRIBUTORS BE LIABLE FOR ANY DIRECT, INDIRECT, INCIDENTAL, SPECIAL, EXEMPLARY, OR CONSEQUENTIAL DAMAGES (INCLUDING, BUT NOT LIMITED TO, PROCUREMENT OF SUBSTITUTE GOODS OR SERVICES; LOSS OF USE, DATA, OR PROFITS; OR BUSINESS INTERRUPTION) HOWEVER CAUSED AND ON ANY THEORY OF LIABILITY, WHETHER IN CONTRACT, STRICT LIABILITY, OR TORT (INCLUDING NEGLIGENCE OR OTHERWISE) ARISING IN ANY WAY OUT OF THE USE OF THIS SOFTWARE, EVEN IF ADVISED OF THE POSSIBILITY OF SUCH DAMAGE.

(51)

From musl src/string/strverscmp.c

Copyright © 2005-2014 Rich Felker, et al.

Permission is hereby granted, free of charge, to any person obtaining a copy of this software and associated documentation files (the "Software"), to deal in the Software without restriction, including without limitation the rights to use, copy, modify, merge, publish, distribute, sublicense, and/or sell copies of the Software, and to permit persons to whom the Software is furnished to do so, subject to the following conditions:

The above copyright notice and this permission notice shall be included in all copies or substantial portions of the Software.

THE SOFTWARE IS PROVIDED "AS IS", WITHOUT WARRANTY OF ANY KIND, EXPRESS OR IMPLIED, INCLUDING BUT NOT LIMITED TO THE WARRANTIES OF MERCHANTABILITY, FITNESS FOR A PARTICULAR PURPOSE AND NONINFRINGEMENT. IN NO EVENT SHALL THE AUTHORS OR COPYRIGHT HOLDERS BE LIABLE FOR ANY CLAIM, DAMAGES OR OTHER LIABILITY, WHETHER IN AN ACTION OF CONTRACT, TORT OR OTHERWISE, ARISING FROM, OUT OF OR IN CONNECTION WITH THE SOFTWARE OR THE USE OR OTHER DEALINGS IN THE SOFTWARE.

(52)

++Copyright++ 1983, 1993

-

Copyright (c) 1983, 1993

The Regents of the University of California. All rights reserved.

Redistribution and use in source and binary forms, with or without modification, are permitted provided that the following conditions are met:

1. Redistributions of source code must retain the above copyright notice, this list of conditions and the following disclaimer.
2. Redistributions in binary form must reproduce the above copyright notice, this list of conditions and the following disclaimer in the documentation and/or other materials provided with the distribution.
3. Neither the name of the University nor the names of its contributors may be used to endorse or promote products derived from this software without specific prior written permission.

THIS SOFTWARE IS PROVIDED BY THE REGENTS AND CONTRIBUTORS "AS IS" AND ANY EXPRESS OR IMPLIED WARRANTIES, INCLUDING, BUT NOT LIMITED TO, THE IMPLIED WARRANTIES OF MERCHANTABILITY AND FITNESS FOR A PARTICULAR PURPOSE ARE DISCLAIMED. IN NO EVENT SHALL THE REGENTS OR CONTRIBUTORS BE LIABLE FOR ANY DIRECT, INDIRECT, INCIDENTAL, SPECIAL, EXEMPLARY, OR CONSEQUENTIAL DAMAGES (INCLUDING, BUT NOT LIMITED TO, PROCUREMENT OF SUBSTITUTE GOODS OR SERVICES; LOSS OF USE, DATA, OR PROFITS; OR BUSINESS INTERRUPTION) HOWEVER CAUSED AND ON ANY THEORY OF LIABILITY, WHETHER IN CONTRACT, STRICT LIABILITY, OR TORT (INCLUDING NEGLIGENCE OR OTHERWISE) ARISING IN ANY WAY OUT OF THE USE OF THIS SOFTWARE, EVEN IF ADVISED OF THE POSSIBILITY OF SUCH DAMAGE.

-

Portions Copyright (c) 1993 by Digital Equipment Corporation.

Permission to use, copy, modify, and distribute this software for any purpose with or without fee is hereby granted, provided that the above copyright notice and this permission notice appear in all copies, and that the name of Digital Equipment Corporation not be used in advertising or publicity pertaining to distribution of the document or software without specific, written prior permission.

THE SOFTWARE IS PROVIDED "AS IS" AND DIGITAL EQUIPMENT CORP. DISCLAIMS ALL WARRANTIES WITH REGARD TO THIS SOFTWARE, INCLUDING ALL IMPLIED WARRANTIES OF MERCHANTABILITY AND FITNESS. IN NO EVENT SHALL DIGITAL EQUIPMENT CORPORATION BE LIABLE FOR ANY SPECIAL, DIRECT, INDIRECT, OR CONSEQUENTIAL DAMAGES OR ANY DAMAGES WHATSOEVER RESULTING FROM LOSS OF USE, DATA OR PROFITS, WHETHER IN AN ACTION OF CONTRACT, NEGLIGENCE OR OTHER TORTIOUS ACTION, ARISING OUT OF OR IN CONNECTION WITH THE USE OR PERFORMANCE OF THIS SOFTWARE.

-  
--Copyright--

(53)  
Copyright (c) 2015 John Baldwin <jhb@FreeBSD.org>.  
All rights reserved.

Redistribution and use in source and binary forms, with or without modification, are permitted provided that the following conditions are met:

1. Redistributions of source code must retain the above copyright notice, this list of conditions and the following disclaimer.
2. Redistributions in binary form must reproduce the above copyright notice, this list of conditions and the following disclaimer in the documentation and/or other materials provided with the distribution.
3. Neither the name of the author nor the names of its contributors may be used to endorse or promote products derived from this software without specific prior written permission.

THIS SOFTWARE IS PROVIDED BY THE REGENTS AND CONTRIBUTORS "AS IS" AND ANY EXPRESS OR IMPLIED WARRANTIES, INCLUDING, BUT NOT LIMITED TO, THE IMPLIED WARRANTIES OF MERCHANTABILITY AND FITNESS FOR A PARTICULAR PURPOSE ARE DISCLAIMED. IN NO EVENT SHALL THE REGENTS OR CONTRIBUTORS BE LIABLE FOR ANY DIRECT, INDIRECT, INCIDENTAL, SPECIAL, EXEMPLARY, OR CONSEQUENTIAL DAMAGES (INCLUDING, BUT NOT LIMITED TO, PROCUREMENT OF SUBSTITUTE GOODS OR SERVICES; LOSS OF USE, DATA, OR PROFITS; OR BUSINESS INTERRUPTION) HOWEVER CAUSED AND ON ANY THEORY OF LIABILITY, WHETHER IN CONTRACT, STRICT LIABILITY, OR TORT (INCLUDING NEGLIGENCE OR OTHERWISE) ARISING IN ANY WAY OUT OF THE USE OF THIS SOFTWARE, EVEN IF ADVISED OF THE POSSIBILITY OF SUCH DAMAGE.

(54)  
Copyright (C) 1995, 1996, 1997, and 1998 WIDE Project.  
All rights reserved.

Redistribution and use in source and binary forms, with or without modification, are permitted provided that the following conditions are met:

1. Redistributions of source code must retain the above copyright notice, this list of conditions and the following disclaimer.
2. Redistributions in binary form must reproduce the above copyright notice, this list of conditions and the following disclaimer in the documentation and/or other materials provided with the distribution.
3. Neither the name of the project nor the names of its contributors may be used to endorse or promote products derived from this software without specific prior written permission.

THIS SOFTWARE IS PROVIDED BY THE PROJECT AND CONTRIBUTORS "AS IS" AND ANY EXPRESS OR IMPLIED WARRANTIES, INCLUDING, BUT NOT LIMITED TO, THE IMPLIED WARRANTIES OF MERCHANTABILITY AND FITNESS FOR A PARTICULAR PURPOSE ARE DISCLAIMED. IN NO EVENT SHALL THE PROJECT OR CONTRIBUTORS BE LIABLE FOR ANY DIRECT, INDIRECT, INCIDENTAL, SPECIAL, EXEMPLARY, OR CONSEQUENTIAL DAMAGES (INCLUDING, BUT NOT LIMITED TO, PROCUREMENT OF SUBSTITUTE GOODS OR SERVICES; LOSS OF USE, DATA, OR PROFITS; OR BUSINESS INTERRUPTION) HOWEVER CAUSED AND ON ANY THEORY OF LIABILITY, WHETHER IN CONTRACT, STRICT LIABILITY, OR TORT

(INCLUDING NEGLIGENCE OR OTHERWISE) ARISING IN ANY WAY OUT OF THE USE OF THIS SOFTWARE, EVEN IF ADVISED OF THE POSSIBILITY OF SUCH DAMAGE.

\$KAME: in6.h,v 1.89 2001/05/27 13:28:35 itojun Exp \$

(55)  
Copyright (c) 2008, Jeffrey Roberson <jeff@freebsd.org>  
All rights reserved.

Copyright (c) 2008 Nokia Corporation  
All rights reserved.

Redistribution and use in source and binary forms, with or without modification, are permitted provided that the following conditions are met:

1. Redistributions of source code must retain the above copyright notice unmodified, this list of conditions, and the following disclaimer.
2. Redistributions in binary form must reproduce the above copyright notice, this list of conditions and the following disclaimer in the documentation and/or other materials provided with the distribution.

THIS SOFTWARE IS PROVIDED BY THE AUTHOR "AS IS" AND ANY EXPRESS OR IMPLIED WARRANTIES, INCLUDING, BUT NOT LIMITED TO, THE IMPLIED WARRANTIES OF MERCHANTABILITY AND FITNESS FOR A PARTICULAR PURPOSE ARE DISCLAIMED. IN NO EVENT SHALL THE AUTHOR BE LIABLE FOR ANY DIRECT, INDIRECT, INCIDENTAL, SPECIAL, EXEMPLARY, OR CONSEQUENTIAL DAMAGES (INCLUDING, BUT NOT LIMITED TO, PROCUREMENT OF SUBSTITUTE GOODS OR SERVICES; LOSS OF USE, DATA, OR PROFITS; OR BUSINESS INTERRUPTION) HOWEVER CAUSED AND ON ANY THEORY OF LIABILITY, WHETHER IN CONTRACT, STRICT LIABILITY, OR TORT (INCLUDING NEGLIGENCE OR OTHERWISE) ARISING IN ANY WAY OUT OF THE USE OF THIS SOFTWARE, EVEN IF ADVISED OF THE POSSIBILITY OF SUCH DAMAGE.

\$FreeBSD: head/sys/sys/\_bitset.h 299184 2016-05-06 16:41:23Z royger \$

(56)  
Copyright (c) 1982, 1986, 1990, 1993, 1994  
The Regents of the University of California. All rights reserved.  
(c) UNIX System Laboratories, Inc.

All or some portions of this file are derived from material licensed to the University of California by American Telephone and Telegraph Co. or Unix System Laboratories, Inc. and are reproduced herein with the permission of UNIX System Laboratories, Inc.

Redistribution and use in source and binary forms, with or without modification, are permitted provided that the following conditions are met:

1. Redistributions of source code must retain the above copyright notice, this list of conditions and the following disclaimer.
2. Redistributions in binary form must reproduce the above copyright notice, this list of conditions and the following disclaimer in the documentation and/or other materials provided with the distribution.
3. Neither the name of the University nor the names of its contributors may be used to endorse or promote products derived from this software without specific prior written permission.

THIS SOFTWARE IS PROVIDED BY THE REGENTS AND CONTRIBUTORS "AS IS" AND ANY EXPRESS OR IMPLIED WARRANTIES, INCLUDING, BUT NOT LIMITED TO, THE IMPLIED WARRANTIES OF MERCHANTABILITY AND FITNESS FOR A PARTICULAR PURPOSE ARE DISCLAIMED. IN NO EVENT SHALL THE REGENTS OR CONTRIBUTORS BE LIABLE FOR ANY DIRECT, INDIRECT, INCIDENTAL, SPECIAL, EXEMPLARY, OR CONSEQUENTIAL DAMAGES (INCLUDING, BUT NOT LIMITED TO, PROCUREMENT OF SUBSTITUTE GOODS OR SERVICES; LOSS OF USE, DATA, OR PROFITS; OR BUSINESS INTERRUPTION) HOWEVER CAUSED AND ON ANY THEORY OF LIABILITY, WHETHER IN CONTRACT, STRICT LIABILITY, OR TORT (INCLUDING NEGLIGENCE OR OTHERWISE) ARISING IN ANY WAY OUT OF THE USE OF THIS SOFTWARE, EVEN IF ADVISED OF THE POSSIBILITY OF SUCH DAMAGE.

@(#)filio.h 8.1 (Berkeley) 3/28/94  
\$FreeBSD: head/sys/sys/filio.h 314436 2017-02-28 23:42:47Z imp \$

# Copyrights, etc. (OSS) (Continued)

---

(57)

Configuration for math routines.  
Copyright (c) 2017 ARM Ltd. All rights reserved.

Redistribution and use in source and binary forms, with or without modification, are permitted provided that the following conditions are met:

1. Redistributions of source code must retain the above copyright notice, this list of conditions and the following disclaimer.
2. Redistributions in binary form must reproduce the above copyright notice, this list of conditions and the following disclaimer in the documentation and/or other materials provided with the distribution.
3. The name of the company may not be used to endorse or promote products derived from this software without specific prior written permission.

THIS SOFTWARE IS PROVIDED BY ARM LTD "AS IS AND ANY EXPRESS OR IMPLIED WARRANTIES, INCLUDING, BUT NOT LIMITED TO, THE IMPLIED WARRANTIES OF MERCHANTABILITY AND FITNESS FOR A PARTICULAR PURPOSE ARE DISCLAIMED. IN NO EVENT SHALL ARM LTD BE LIABLE FOR ANY DIRECT, INDIRECT, INCIDENTAL, SPECIAL, EXEMPLARY, OR CONSEQUENTIAL DAMAGES (INCLUDING, BUT NOT LIMITED TO, PROCUREMENT OF SUBSTITUTE GOODS OR SERVICES; LOSS OF USE, DATA, OR PROFITS; OR BUSINESS INTERRUPTION) HOWEVER CAUSED AND ON ANY THEORY OF LIABILITY, WHETHER IN CONTRACT, STRICT LIABILITY, OR TORT (INCLUDING NEGLIGENCE OR OTHERWISE) ARISING IN ANY WAY OUT OF THE USE OF THIS SOFTWARE, EVEN IF ADVISED OF THE POSSIBILITY OF SUCH DAMAGE.

(58)

Copyright (c) 2007 The NetBSD Foundation, Inc.  
All rights reserved.

This code is derived from software written by Stephen L. Moshier.  
It is redistributed by the NetBSD Foundation by permission of the author.

Redistribution and use in source and binary forms, with or without modification, are permitted provided that the following conditions are met:

1. Redistributions of source code must retain the above copyright notice, this list of conditions and the following disclaimer.
2. Redistributions in binary form must reproduce the above copyright notice, this list of conditions and the following disclaimer in the documentation and/or other materials provided with the distribution.

THIS SOFTWARE IS PROVIDED BY THE NETBSD FOUNDATION, INC. AND CONTRIBUTORS "AS IS" AND ANY EXPRESS OR IMPLIED WARRANTIES, INCLUDING, BUT NOT LIMITED TO, THE IMPLIED WARRANTIES OF MERCHANTABILITY AND FITNESS FOR A PARTICULAR PURPOSE ARE DISCLAIMED. IN NO EVENT SHALL THE FOUNDATION OR CONTRIBUTORS BE LIABLE FOR ANY DIRECT, INDIRECT, INCIDENTAL, SPECIAL, EXEMPLARY, OR CONSEQUENTIAL DAMAGES (INCLUDING, BUT NOT LIMITED TO, PROCUREMENT OF SUBSTITUTE GOODS OR SERVICES; LOSS OF USE, DATA, OR PROFITS; OR BUSINESS INTERRUPTION) HOWEVER CAUSED AND ON ANY THEORY OF LIABILITY, WHETHER IN CONTRACT, STRICT LIABILITY, OR TORT (INCLUDING NEGLIGENCE OR OTHERWISE) ARISING IN ANY WAY OUT OF THE USE OF THIS SOFTWARE, EVEN IF ADVISED OF THE POSSIBILITY OF SUCH DAMAGE.

(59)

(c) Copyright 2017 Michael R. Neilly  
All rights reserved.

Redistribution and use in source and binary forms, with or without modification, are permitted provided that the following conditions are met:

\* Redistributions of source code must retain the above copyright notice, this list of conditions and the following disclaimer.

\* Redistributions in binary form must reproduce the above copyright notice, this list of conditions and the following disclaimer in the documentation and/or other materials provided with the distribution.

\* Neither the names of the copyright holders nor the names of their contributors may be used to endorse or promote products derived from this software without specific prior written permission.

THIS SOFTWARE IS PROVIDED BY THE COPYRIGHT HOLDERS AND CONTRIBUTORS "AS IS" AND ANY EXPRESS OR IMPLIED WARRANTIES, INCLUDING, BUT NOT LIMITED TO, THE IMPLIED WARRANTIES OF MERCHANTABILITY AND FITNESS FOR A PARTICULAR PURPOSE ARE DISCLAIMED. IN NO EVENT SHALL THE COPYRIGHT OWNER OR CONTRIBUTORS BE LIABLE FOR ANY DIRECT, INDIRECT, INCIDENTAL, SPECIAL, EXEMPLARY, OR CONSEQUENTIAL DAMAGES (INCLUDING, BUT NOT LIMITED TO, PROCUREMENT OF SUBSTITUTE GOODS OR SERVICES; LOSS OF USE, DATA, OR PROFITS; OR BUSINESS INTERRUPTION) HOWEVER CAUSED AND ON ANY THEORY OF LIABILITY, WHETHER IN CONTRACT, STRICT LIABILITY, OR TORT (INCLUDING NEGLIGENCE OR OTHERWISE) ARISING IN ANY WAY OUT OF THE USE OF THIS SOFTWARE, EVEN IF ADVISED OF THE POSSIBILITY OF SUCH DAMAGE.

# Warranty policy

---

This warranty is provided in accordance with applicable Australian or New Zealand legislation and does not exclude, restrict or modify any rights you may have under the relevant laws.

Subject to the conditions stated in this document, if Panasonic or its authorised service centre determines that any of the above-listed items are defective within the applicable warranty period, the component will be repaired or replaced free of charge.

## Australia:

This warranty applies only to Panasonic products purchased in Australia from Panasonic Australia or its authorised distributors or dealers and used and serviced within Australia or its territories.

For more information, please visit the Panasonic website. (Back cover)

## New Zealand:

This warranty applies only to Panasonic products purchased in New Zealand from Panasonic New Zealand or its authorised distributors or dealers and used and serviced within New Zealand or its territories.

For more information, please visit the Panasonic website. (Back cover)

# MEMO

---



# Helpdesks

---

## Australia

---

Please search for 'Customer helpdesks' on the website below and contact us.

<https://www.panasonic.com/au/>

## New Zealand

---

Please search for 'Customer helpdesks' on the website below and contact us.

<https://www.panasonic.com/nz/>

## To all our valued customers

---

Please record the following details in preparation for any future installation or service requirements.  
(Check the box next to the model number.)

■ Purchase Date:

---

■ Retailer and Contractor:

---

---

■ Covering Model Number:

**CO<sub>2</sub> HEAT PUMP UNIT**

HE-UM60CR

HE-UM40CR

**CONTROLLER**

HE-1MAHR

**TANK UNIT**

HE-TM400AHR

HE-TM315AHR

HE-TM250AHR

**Panasonic Corporation**

1006, Oaza Kadoma, Kadoma City, Osaka 571-8501, Japan

© Panasonic Corporation 2025