

# Operating Instructions

**Household Use** | **IH** Electronic Rice Cooker

**Model No. SR-HNS151**

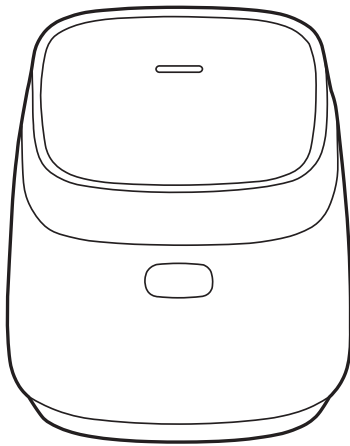

As the pictures in these Instructions are only schematic diagrams, please refer to the actual product.  
中文请参考P21-封底。

- Thank you for purchasing this Panasonic product.
- This appliance is intended to be used in household and similar applications.
  - Please read these Operating Instructions carefully for safe and proper use of this product.
  - **Be sure to read the "Safety Precautions" (page 2-3) before use.**
  - Keep the operating instructions for future use.



Keep for future use

## Contents

<p><b>Safety Precautions</b> ..... 2-3</p> <p><b>Instructions for Use</b> ..... 4</p> <p><b>Parts Identification</b></p> <ul style="list-style-type: none"> <li>● Main body .....5</li> <li>● Control panel/Adjust the current time .....6</li> </ul>	Before Use
<p><b>Preparation</b></p> <ul style="list-style-type: none"> <li>● Wash rice and add water ..... 7</li> <li>● Function selecting/Setting cooking time/ Tips to cook delicious rice .....8</li> </ul> <p><b>Menu Functions</b></p> <ul style="list-style-type: none"> <li>● Cook Rice/Keep warm/Reheat .....9</li> <li>● Congee · Steam · Soup · Stew .....10</li> <li>● Cake · Ferment/Timer .....11</li> </ul> <p><b>Cleaning and Maintenance</b> ..... 12-13</p> <p><b>Recipes</b> ..... 14-15</p>	
<p><b>Troubleshooting</b> ..... 16-17</p> <p><b>Error Codes Indication</b> ..... 18</p> <p><b>When you want to improve(optimize)</b>..... 19</p> <p><b>Specifications</b> ..... 20</p>	Troubleshooting

# Safety Precautions

Be sure to observe the following precautions

To prevent personal injury, injury to others and property damage, the following instructions must be followed.

■ The following symbols show the damage or harm level caused by incorrect operation.

 **WARNING:** Indicate a potential hazard which could result in death or serious injury.

 **CAUTION:** Indicate a potential hazard which could result in injury or damage to property.



■ Classification and description of symbols are as follows.

 This symbol indicates an action that is prohibited.

 This symbol indicates an action that must be followed.

## WARNING





### ■ Power supply · Power cord · Power plug

-  ● **Do not use the appliance if the power cord or power plug is damaged or the power plug is loosely connected to the power outlet.**  
(To avoid causing an electric shock, or a fire due to a short circuit.)  
→ If the power cord is damaged, it must be replaced by a special cord or assembly available from the manufacturer or its service agent.
- **Do not damage the power cord or power plug.**  
· The following actions are strictly prohibited:  
Damaging, processing, making contact with or near high temperature surfaces or heating elements, forcibly bending, twisting, pulling, hanging/pulling over sharp corners, placing heavy objects on it, tying into bundles, sandwiching, pulling the power cord to move.  
(So as to avoid electric shock due to damaged power cord and power plug or avoid fire due to short circuit.)
- **Do not connect or disconnect the power plug with wet hands.**  
· Make sure your hands are dry before touching the power plug or the product.  
(To avoid causing an electric shock or injury.)
- **Please do not let anyone lick the plug.**  
(To avoid causing an electric shock or injury.)  
· Pay special attention to infants and young children.
- **Do not spill water or other liquids on the instrument plug.**  
(To avoid causing an electric shock, or fire due to a short circuit.)
-  ● **Please use an alternating current power socket with the voltage of 10 A, 230 V.**  
(Using the unit together with other equipment on the same outlet can cause overheating and fire.)  
· Only use a power strip rated at least 10 amperes.
- **Make sure that the power plug and the instrument plug are fully inserted in place.**  
(To avoid causing smoke, fire or electric shock.)
- **Single-phase bipolar grounded power outlets should be used for this appliance to ensure reliable grounding. If a grounding device is not installed, electrostatic induction of other metal parts such as housing may occur.**  
(To avoid causing the risk of electric shock due to failure or electric leakage.)

### ● Clean the power plug regularly.

(To avoid causing a fire due to poor insulation of the power plug due to accumulation of moisture and foreign matter.)  
→ Disconnect the power plug and wipe it with a dry cloth.

### ■ Main body

-  ● **Do not insert anything into intake port, exhaust port or gap.**  
· Especially pin or other metal objects.  
(To avoid causing an electric shock or abnormal operation.)  

- **Do not place items which may clog the hole on the inner lid into the pan.**  
(To avoid causing burns or injuries resulting from steam or cooked food blowing out.)  
Cooking methods which involve ingredients and seasonings that are placed into a plastic bag to heat cannot be done with this appliance.  

- **Do not modify, disassemble, or repair this appliance.**  
(To avoid causing a fire, electric shock or injury.)  
→ For repair, please contact a Panasonic authorized service center.
- **Do not use this appliance for any purpose other than those described in the Operating Instructions.**  
(To avoid causing a fire, burn, injury or electric shock.)  
· Panasonic shall not assume any responsibility for improper use or failure to follow the operating instructions.
- **Do not immerse the appliance in water or splash it with water.**  
(To avoid causing an electric shock, or a fire due to a short circuit.)  
→ Please contact a Panasonic authorized service center if water gets inside the appliance.  

# ! WARNING

## ■ Use

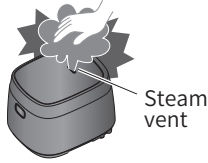

- **When in use or after cooking, do not put your face or hands near the steam vent. Special attention must be paid to children and infants.**  
(To avoid causing a burn.)



- **Keep the appliance out of reach of small children.**  
(To avoid causing burns, injury or electric shock.)
- **If an abnormality or malfunction occurs, stop using the appliance immediately and unplug the power plug.**  
(To avoid causing smoke, fire or electric shock.)

- **Do not open the lid or move the main body during cooking.**  
→If you need to open the lid halfway, please be careful.  
(So as to avoid burns or injuries resulting from steam or cooked food blowing out.)



- **This appliance is not intended for use by persons (including children) with reduced physical, sensory or mental capabilities, or lack of experience and knowledge, unless they have been given supervision or instruction concerning use of the appliance by a person responsible for their safety. Children should be supervised to ensure that they do not play with the appliance.**  
(To avoid causing burns, injury or electric shock.)

### Abnormalities - Malfunction Cases:

- The power plug and cord become abnormally hot.
  - The power cord is damaged or there are intermittent power outages when being touched.
  - The main body is deformed or abnormally hot.
  - The main body emits smoke or a burning smell.
  - The main body is broken, loose or makes abnormal noise.
  - The fan at the bottom does not rotate during cooking.
- Please contact a Panasonic authorized service center for inspection and repair immediately.

# ! CAUTION



- **Do not use a non-dedicated pan or a deformed pan.**  
(To avoid causing burns or injury due to overheating or malfunction.)

- **Do not use the appliance in the following places:**

- Near heat or in high humidity environments.  
(To avoid causing electric shock, electric leakage or fire.)
- On uneven surfaces or a mat which is not heat-resistant.  
(To avoid causing injury, burns or fire.)
- In places close to walls or furniture, etc.  
(To avoid bumping into them when opening the outer lid, or causing discoloration, deformation and breakage of the furniture.)
- On an aluminum plate or an electronic mat.  
(Aluminum material may generate heat and cause smoke or fire.)

- **Do not move the main body while in use.**  
(So as to avoid burns caused by the opening of the outer lid due to touching the hook button.)

- **Do not touch the hot surfaces while the appliance is in use or after cooking.**

- The main body has a high temperature.  
In particular, the metal parts such as the inner lid, the pan.  
(To avoid causing a burn.)



- **Do not use the power cord not specified for use with this appliance or using the power cord provided with this appliance for any other device.**  
(So as to avoid malfunctions or electric shock, electric leakage or fire.)

- **Do not expose the power plug to the steam.**

- (To avoid causing an electric shock, or fire due to a short circuit.)  
→When using a cabinet with sliding table, use the appliance where the power plug cannot be exposed to steam.



- **Do not let the appliance operate in an empty state.**  
(To avoid causing burns.)

- **Do not connect the appliance to an external timing device or operate the appliance using a separate remote control system.**  
(To avoid fire.)



- **When you unplug the power plug, be sure to hold the plug itself, and never pull the power cord.**  
(To avoid causing an electric shock, or a fire due to a short circuit.)

- **When taking out the pan or when the pan is not in use, remember to turn off the power and unplug the power plug.**

- (To avoid causing burns, injury, or an electric shock, leakage, fire due to insulation aging.)

- **Wait for the main body to cool down sufficiently before cleaning.**  
(To avoid causing burns.)

- **When used within a cupboard or other enclosed spaces, make sure that the steam can emit outward.**  
(To avoid causing discoloration or deformation of the cupboard.)

- **If you have an implantable cardiac pacemaker in your body, please consult a physician before using this appliance.**  
(This appliance may have an impact on a pacemaker when it is operated.)

- **This appliance is intended to be used in household and similar applications such as:**

- staff kitchen areas in shops, offices and other working environments;
- farm houses;
- by clients in hotels, motels and other residential type environments;
- bed and breakfast type environments.

## If a power outage occurs during use

This includes unplugging of the power plug, trip, etc.

- In case of an instantaneous power outage, the rice cooker will return to the state before the power outage.
- If the power outage lasts for a long time, the following will happen after the power is turned on again.  
Cooking: Continue to cook.  
It may affect the cooking effect.  
Keeping warm: Continue to keep warm.

# Instructions for Use

## About the Main Body

- If the product is on a cabinet with sliding table, make sure that the load capacity of the table is greater than 12 kg.  
(To avoid dropping the product.)

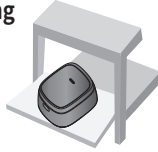

- Do not cover the outer lid with a cloth or other objects when the product is in use.

(To avoid causing the steam from being blocked, resulting in deformation, discoloration of the outer lid and malfunction of the product.)



- Periodically check the intake port and the exhaust port at the bottom of the rice cooker, and remove dust.  
(Refer to "Cleaning and Maintenance" on P13)

- Please clean rice and other foreign objects that become stuck on the main body (bottom sensor, bottom of pan and supporting rubber of pan).

(To avoid error displays, scorched rice, half-cooked rice, etc.)

Edge or bottom



(Pan)

Supporting rubber of pan (3 places)

Bottom sensor

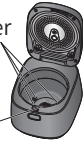

- Do not place the product near a device susceptible to electromagnetic interference.

· Radio, television and hearing aids, etc.  
(So as to avoid noise or reduce the volume.)  
· IC cards, bank cards  
(So as not to damage the magnetic.)

- Do not place the magnet near the product.  
(So as to avoid abnormal operation.)

- Do not use the product on an induction cooker.  
(So as not to damage the induction cooker or cause abnormal operation of the product.)

- Do not use the product outdoors.  
(Unstable power supply may result in product failure.)

- Avoid using the product under direct sunlight.  
(So as to avoid color change/discoloration.)

- Do not use the rice cooker where the bottom of the product (the intake port and the exhaust port) may be clogged.  
For example: on carpet, plastic bag, aluminum foil or fabric, etc.  
(So as not to damage the product.)

## About the Pan

- Do not use the pan in places other than the rice cooker.



- Do not use it on a gas stove or induction cooker or in a microwave.



- Avoid hitting the pan against hard objects.



( Doing so may cause scratches or dents on the outer surface. )



### Daily use

- Avoid dry cooking or containing food with strong acidity and alkalinity for a long time.
- Do not use a metal spoon.  
(While cooking congee and other food).
- This product contains a stainless steel pan. During use, the surface of the pan will be subject to white spots and slight discoloration due to water quality and high temperature, which however will not affect health and use.

### After the cooking is complete



- Do not touch or strike the pan.  
(While filling a bowl with rice)

### During cleaning and maintenance(P12)

- Do not use the pan as a washing container.
- Do not place spoons or other utensils into the pan.
- After cooking with seasoning, do not leave food inside the pan.  
→Please clean out the food in the pan as soon as possible and then clean the pan.
- Do not put the pan onto other utensils to dry after washing.
- For stubborn stains, soak them in hot water and then clean with detergent. You can use a scouring pad for cleaning. After cleaning, dry the pan with a dry cloth.



### Notes

The following will not affect product performance or personal health.  
[Outer surface] superficial scratches, small dents or collisions.  
[Inner surface] scale, white spots or slight discoloration.  
→If the pan is deformed or if you are worried about its condition, please purchase a new pan.

### Tips for non-stick pan

- Before cooking, add a small amount of cooking oil to the pan to effectively reduce the rice sticking to the pan.
- Add rice and water according to the waterline on the pan to effectively reduce the rice sticking to the pan.
- After the rice is cooked, eat it as soon as possible. Long-term keep warm, secondary heating and cold rice are easy to cause rice sticking to the pan.

# Parts Identification

For the first use, clean the pan, inner lid, accessories. (👉 P12-13)

## Main body

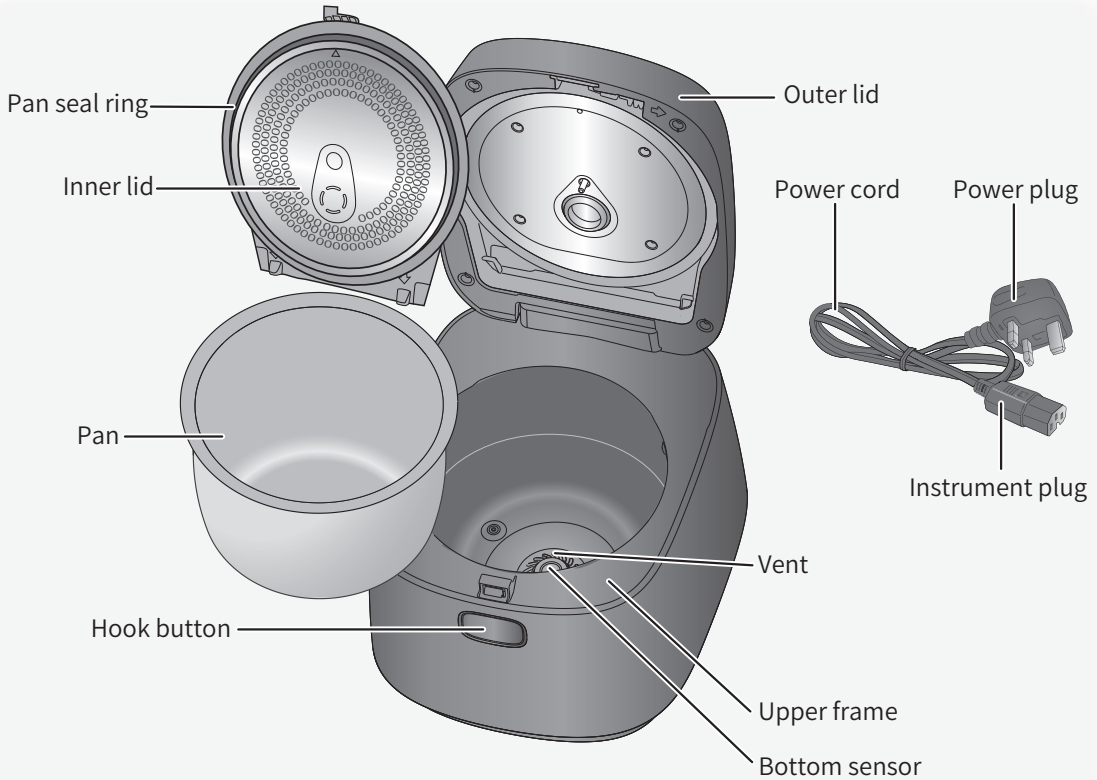
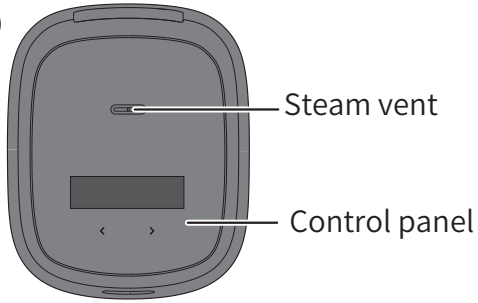

Before Use

## Accessories

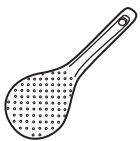

Rice scoop(1)



Porridge [Soup]  
scoop(1)



Measuring cup(1)  
(Approx.180 mL)

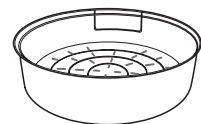

Steaming basket(1)

# Parts Identification/Adjust the current time

**Control panel**

**Off/Cancel**

- Cancel incorrect operation, or turn off keep warm.

**Timer**

- Press this key to use the timer.

**< or >**

- It is used to select the function.
- It is used to adjust the current time, set the preset time and cooking time.
- When setting time, press and hold the key to quickly add or subtract time.

**Start/Reheat**

- Press this key to start cooking or end the setting of the preset time.
- Press it twice for reheat.

**White Regular**

- Press this key to cook white rice in regular mode.

**Time**

- Press this key first to set the cooking time.
- Press and hold this key for 3 seconds to adjust the clock.
- Press this key to check the cooking time in the timer state.

**Keep Warm**

- Press this key to keep food warm.

## Adjust the current time

**Example: To change 7:00 a.m. to 8:30 a.m.**

① Connect the power plug.

② Press and hold the [Time] key for more than 3 seconds. (When hearing the buzzer beep, release the key.) When the "Minute" flashes on the LCD screen, press the [Time] key, and the "Hour" flashes. ※ Only flashing numbers can be adjusted.

③ Press [ < ] or [ > ] to adjust the time. Every time you press the [ < ] or [ > ] key, the "minute" is increased or decreased in units of 1 minute unit, and the "hour" is increased or decreased in units of 1 hour. (After the time is adjusted, if the number flashes several times and then stop automatically, the time adjustment is completed.)

※ Time cannot be adjusted under working condition.  
 ※ Press and hold the [ < ] or [ > ] key to quickly add or subtract time.  
 ※ The clock is with 24 hour display, and 24:00 is expressed by 0:00.  
 ※ If there is an error in time display, there will be an error in the scheduled cooking time and the cooking end time. Please adjust it in time.

# Preparation

## Wash rice and add water

Before using for the first time

Boil a pan of water, then drained it.

- ① Add water to the maximum waterline of "Long-grain" and close the outer lid.
- ② Select the "Steam" function, and set the cooking time to 15 minutes.
- ③ When you hear the buzzer, remove the pan, and pour away the water inside it.

# 1

Measure rice with the measuring cup provided

- Check the maximum quantity of rice that can be cooked at once, (👉 "Specifications" on P20.

○ Correct



About 180 mL  
(about 150 g)

✗ Incorrect

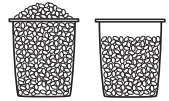

# 2

Wash the rice until the water turns relatively clear

- ① Wash the rice quickly with plenty of water, changing the water as you go.
  - ② Stir the rice gently, and repeat washing several times → rinse with water until the water turns relatively clear.
- Wash the rice thoroughly. Otherwise, rice crust may appear and the residual rice bran may affect the taste of the rice.

①

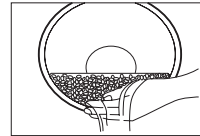

②



# 3

Place the washed rice into the pan

Add water up to the corresponding waterline (👉 P8) and dry the outside of the pan.

- When cooking rice, please select the appropriate waterline according to the rice type.  
**"Long-grain"**: For elongated long-grain rice with a grain length of more than 5 mm.  
**"Short-grain"**: For short and round short-grain rice with a grain length of less than 5 mm.
- When adding water, place the pan on a flat surface and flatten the surface of the rice.  
 (Confirm that the right amount of water is added based on the correct scale.)
- The above water quantities can be increased or decreased according to personal preference.  
 (When too much water is added, it may overflow when cooking.)

Example) When cooking 4 cups of rice, add water to the waterline "4" for "Long-grain".

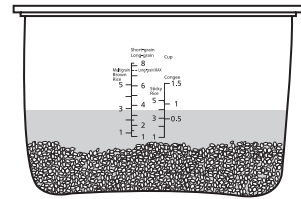

# 4

Put the pan into the body and close the outer lid

- When closing the outer lid, please make sure that a "click" closing sound is heard. If the inner lid is not installed correctly, the outer lid cannot be closed. (👉 P12 inner lid)

①

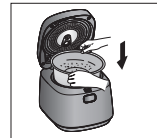

②

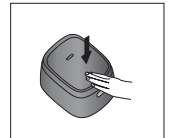

# 5

Connect the plugs

- Plug in the instrument plug, then the power plug, and make sure both are connected securely.

①

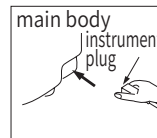

②

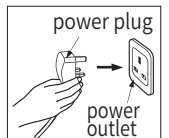

Attention

When cooking rice and steaming food with a steaming basket, the maximum cooking capacity of rice is 4 cups.

# Preparation Function selecting/Setting cooking time/Tips to cook delicious rice

## ■ Function selecting

Table 2

Categories of food to cook	Menu select	Waterline	<sup>1</sup> Cooking time (Approx.)	<sup>2</sup> Keep Warm(auto)	<sup>3</sup> Preset timer options
White Rice	White Regular	Long-grain	37 minutes	○	More than 50 minutes
	Enhanced Taste		48 minutes	○	More than 60 minutes
	Quick/Quinoa <sup>4</sup>		27 minutes	○	More than 40 minute
Short-grain	Short-grain	Short-grain	47 minutes	○	More than 60 minute
Congee	Congee	Congee	Table 3	×	Cooking time + 1 minute - 24hours
Sticky rice	Sticky Rice	Sticky rice	37 minutes	×	More than 50 minutes
Brown rice	Brown Rice	Brown Rice	1 hour 30 minutes	×	More than 2 hours
Steam	Steam	Please add 4 cups of water when steaming for more than 60 minutes	Table 3	×	Cooking time + 20 minutes - 24 hours
Ferment	Ferment	-		×	-
Slow cook	Slow Cook	To the maximum waterline of "Congee"		×	-
Cake	Cake	-		×	-
Stew	Stew	To the maximum waterline of "Congee"		×	-
Soup	Soup			×	-
Reheat	Reheat	Refer to P9 Table 4		15 minutes	○

\*1 · These cooking times are based on a room temperature of 20°C and a water temperature of 20°C, and with a medium amount of rice (4 cups) and at a voltage of 230 V.

· The actual cooking time will vary according to the amount of rice, water, voltage, temperature, water temperature and rice quality.

· The cooking time of sticky rice will vary according to the ingredients used.

\*2 · At the end of cooking, the unit will automatically change to "Keep Warm". It is not recommended that foods marked with "x" are kept warm with this function. Please press the [Off/Cancel] key as soon as possible after cooking has ended.

\*3 · The Soup, Stew, Cake, Ferment and Reheat functions do not have a timer function. · When the preset time is less than the cooking time, cooking will be carried out directly. · In summer when temperature is high, the preset time should not be greater than 8 hours to avoid rice deterioration.

\*4 · Quinoa can only be cooked one cup at a time, requires 1.5 cups of water (Approx 270 mL).

## ■ Setting cooking time

Table 3

Categories of food to cook	Menu select	Cooking time range	Setting increments	Initial value	Time display	Time memory*
Cook congee	Congee	40 minutes-2 hours	10 minutes	1 hour	Back to 40 minutes after 2 hours	○
Steam	Steam	1 minute-60 minutes	1 minute	5 minutes	Back to 1 minute after 60 minutes	○
Soup	Soup	40 minutes-2 hours	10 minutes	1 hour	Back to 40 minutes after 2 hours	○
Stew	Stew	1 hour-4 hours	10 minutes	1 hour	Back to 1 hour after 4 hours	○
Cake	Cake	40 minutes-60 minutes	1 minute	60 minutes	Back to 40 minutes after 60 minutes	○
Ferment	Ferment	30 minutes-12 hours	30 minutes	2 hours	Back to 30 minutes after 12 hours	○
Slow Cook	Slow Cook	1 hour-12 hours	30 minutes	1 hour	Back 12 hours after 1 hour	○

## ★ Tips to cook delicious rice

- ① ● Measure water and rice correctly.
- ② ● Wash rice gently and quickly. ● Do not place rice in a sieve. (To avoid rice fragmentation or rice sticking to the pan.)
- ③ ● Add water to the pan on a flat countertop. ● Do not use hot water or alkaline water with a pH higher than 9. (So as to avoid rice from sticking to the pan or becoming burned.)



# Menu Functions Cook Rice/Keep warm/Reheat

## ※When cooking with "Enhanced Taste" function

- 1 Press or to select "Enhanced Taste".
  - The selected function flashes.
  - The "Start" indicator flashes.
  - The rice function used last time can be memorized.

- 2 Press to start cooking.

- The "Start" indicator lights up.
- The remaining time decreases in units of 1 minute, and the "Quick/Quinoa" function starts to display the remaining time about 6 minutes before the end of cooking.
- After entering the cooking stage, the remaining cooking time displayed will be automatically adjusted depending on the rice volume. For example, it may sometimes drop from "after 18 minutes" to "after 15 minutes", rather than decreasing in units of 1 minute.

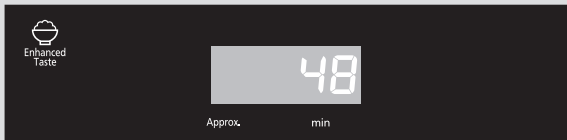

- 3 When cooking is over, loosen the rice.

- After the buzzer rings, cooking has finished. The function will automatically change to keep warm status. To prevent the rice from sticking together, please loosen the rice after cooking.
- For Quinoa, brown rice and sticky rice, please press the [Off/Cancel] key as soon as possible to avoid affecting the taste.

### ■ Please note

- When cooking with the White Regular mode, press and then press "Start".
- When cooking with "Quick/Quinoa", as the cooking time is shortened, the rice may be harder or there may be rice crust. →Soak the rice in water in advance, and you can make the cooked rice become soft.
- Using the "Enhanced Taste" function will make the rice softer and more delicious.
- Do not mix brown rice with white rice, as this may affect the cooking result.

### Keep Warm

- The keeping warm time is displayed for 24 hours from to . After 24 hours, the current time will be displayed but it is still to keep warm. When within 1 hour, it shows hour.
- If the "Keep Warm" function is used for longer than 96 hours, it will automatically stop, and the display will show "U14." To continue use, press the [Off/Cancel] button first.
- Cooked rice should be consumed within 5 hours of keeping warm to avoid discoloration or becoming stale.
- When using the keep warm function, there may be some droplets at the edge of the pan.
- The rice taste may be affected if the rice scoop is left in the pan when the rice is in keep warm function.

## ※When reheating cooled rice Preparation

- Stir the cooled rice in the pan to make it even.
- Please refer to the following table for the amount of water to be added.

Table 4

Cooled rice quantity (Waterline)	Water volume (measuring cup)
0.5	-
1	-
2	1/2
3	1/2
4	1

### ■ Maximum amount of reheat:

Long-grain 4 waterline.

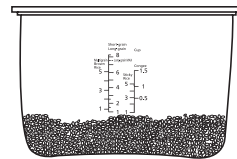

- 1 Press twice to start cooking.

- The "Start" indicator lights up.
- No matter how much cooled rice there is to reheat, the heating time is about 15 minutes.

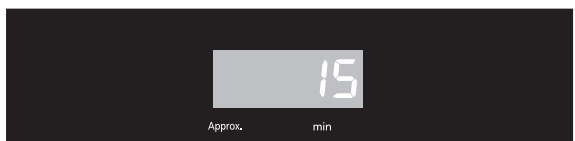

- 2 After the buzzer rings, reheating has finished. The function will automatically change to keep warm status.

- Please loosen the rice as soon as possible, as it will be more delicious.

### ■ Please note

- When adding cooled rice, do not exceed the maximum amount (as shown in Table 4).
- It is recommended to reheat cooled rice only once to avoid affecting the taste of the rice.
- Do not reheat sticky rice, brown rice, or quinoa to avoid affecting the taste.

# Menu Functions

Congee · Steam · Soup · Stew

※When cooking porridge for 1.5 hours

**1** Press or key to select "Congee".

- The selected function menu flashes.
- The [Start] indicator lights up.

**2** Press **Time** and then press or key to set the cooking time.

- Press and hold the [ < ] or [ > ] key to quickly add or subtract time.

- The last cooking time can be memorized.

※For details about what cooking time can be set, P8 Table 3.

**3** Press to start cooking.

- The "Start" indicator lights up.
- The remaining time decreases in unit of 1 minute.



**4** After the buzzer rings, cooking has finished. The function will automatically change to keep warm status.

- Keep warm function will affect taste, press 「Off/Cancel」 key as soon as possible.

## ■ Please note

- Opening the lid during cooking will increase the amount of condensation.
- Incorrect water quantity or rice quantity may lead to overflow of rice water from the steam vent.
- When the porridge is kept in keep warm function for an excessively long time, it will get thicker.
- Soup may overflow if exceeding the "Congee" maximum waterline. ( Specifications on P20)
- After each use, the inner lid should be removed and washed to avoid odor.

※When steaming for 10 minutes

Preparation

- ① Put a proper amount of water into the pan.
- ② Put in a steaming basket.
- ③ Put in the food to be steamed.
- ④ Close the outer lid.



**1** Press or key to select "Steam".

- The selected function menu flashes.
- The [Start] indicator lights up.

**2** Press **Time** and then press or key to set the cooking time.

- Press and hold the [ < ] or [ > ] key to quickly add or subtract time.
- The last cooking time can be memorized.

※For details about what cooking time can be set, P8 Table 3.

**3** Press to start cooking.

- After water boils, the remaining time decreases in units of 1 minute.
- The time shown on the display is the remaining time after the water in the pan boils.



**4** After the buzzer rings, cooking has finished. The function will automatically change to keep warm status.

- Keep warm function will affect taste, press 「Off/Cancel」 key as soon as possible. The steaming basket becomes very hot at this time, so be sure to avoid burning your hands when removing it.

## ■ Please note

- For longer steaming time (over 60 minutes), add 4 cups of water to avoid dry heating.

※When baking a cake with the "Cake" function (50 minutes)

## Preparation

- According to the requirements of cake mix, stir all ingredients evenly.
- Coat a layer of butter (or cooking oil) on the wall of the pan, then pour the stirred cake batter into the pan and close the outer lid.

1 Press or key to select "Cake".

2 Press and then press or key to set the cooking time.

※For details about what cooking time can be set, P8 Table 3.

3 Press to start cooking.

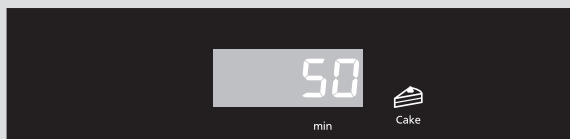

4 After the buzzer rings, cooking has finished. The function will automatically change to keep warm status.

- Keep warm function will affect taste, press 「Off/Cancel」 key as soon as possible.
- Take out the pan and cool it for a few minutes, then turn the pan upside down and pour out the cake. Please be careful when taking out the pan.

### ■ Please note

- Maximum amount of cake batter: 700 g (total weight of cake mix, milk, eggs, etc.), exceeding which may cause the cake to be undercooked.
- Besides cake mix, you can also make cakes with ordinary low-gluten flour. Recipe on P15.
- When baking the largest amount of cake batter, please set the cooking time to 60 minutes to avoid the cake being undercooked.
- Please disinfect the pan and container before fermentation to avoid fermentation failure.

※When "Enhanced Taste" of "White Rice" is finished at 11:30 with "Timer 1" function

- First, confirm whether the current time is correct. If not, please adjust it to the correct time. ( P6)

1 Select the function according to P9~P10.

- The selected function menu flashes.
- The [Start] indicator lights up.

2 Press , and select "Timer 1".

- When using the timer function to cook congee, set the cooking time according to Step 2 in P10, and then press the [Timer] key.
- This product can set two different preset times (such as breakfast and dinner), press the [Timer] key each time, and Timer 1 → Timer 2 → Timer 1 will be displayed alternately.

3 Press or key to set the preset time.

- Press and hold the [ < ] or [ > ] key to quickly add or subtract time.
- When the preset time is less than the cooking time, cooking will be carried out directly.

※ For the functions and time range which apply to the timer P8 Table 2.

4 Press , Timer cooking starts.

- The "Start" indicator goes out, the "Timer" indicator lights up, and the timer setting is completed.
- Please press the [Time] key when confirming the congee cooking time in the timer state.
- When viewing the current time, please press the [Timer] key.

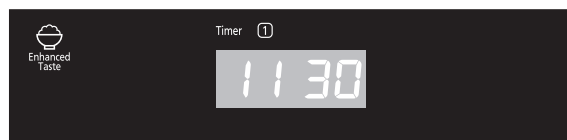

### ■ Please note

- When cooking sticky rice, please do not use the timer function to avoid the deterioration of ingredients or affecting the performance.
- In summer when temperature is high, the preset time should not be greater than 8 hours to avoid rice deterioration.
- The time set by the timer function is the time when cooking is finished.
- The last timer time and cooking time can be memorized.

# Cleaning and Maintenance

## Attention

- Before cleaning, pull out the power plug first. Do not clean the main body until it cools down.
- When cleaning the main body, do not immerse it in water, or clean it with lacquer thinner, gasoline, alcohol, cleaning powder or abrasive materials, etc.

## Inner lid/Pan seal ring

Use neutral detergent for kitchen cleaning.

### ■ When dismantling

- ① Move the inner lid dismantling lever to the right. (The inner lid will tip forward.)
- ② Remove it.

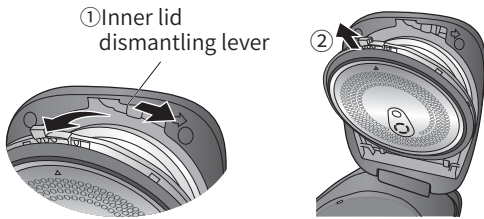

### ■ When installing

- ① Insert the inner lid into the slot. (Both Sides)
- ② Press in the outer lid until you hear a click

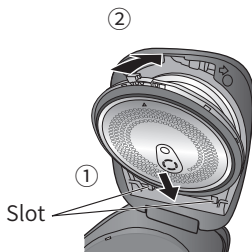

### Notes

- Do not pull the seal ring.
- After each cooking, the inner lid shall be removed for washing. (to avoid odor.)
- Clean it promptly after cooking with seasonings. (Failure to do so may result in odor, deterioration or rusting.)

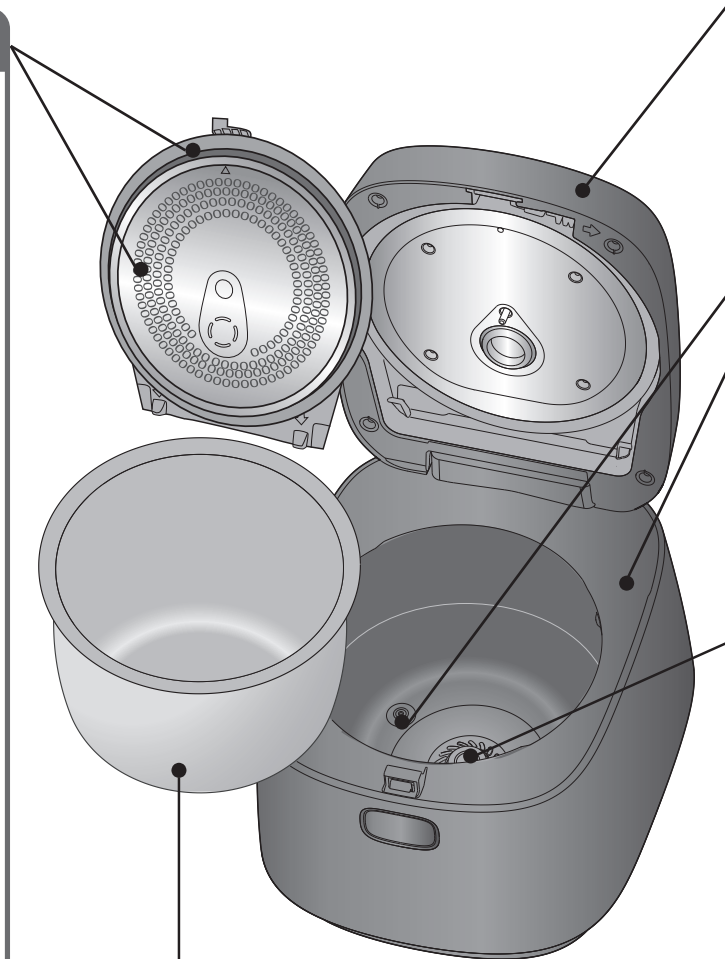

## Pan

- For stubborn stains, soak them in hot water and then clean with detergent. You may use a scouring pad for cleaning. After cleaning, dry the pan with a dry cloth.
- If there are white spots or yellowing on the inner wall of the pan, wipe it with a little edible vinegar or lemon slices; If there are rainbow spots, you can wipe them with vinegar or cola, then rinse and dry it.

# Cleaning and Maintenance

## Inner surface of outer lid

Wipe it with a wrung damp towel.

- Wipe the inner surface of the outer lid.

## Upper frame/Support rubber of pan(3 places)

Wipe with a damp towel.

### Notes

- Do not pour water in to wash.

## Bottom sensor

Wipe with a wet towel wrung.

- If the dirt is difficult to remove, clean with a little kitchen dedicated neutral detergent, and then gently wipe a nylon brush.

### Notes

- If you do not clean the bottom sensor and lid sensor, the rice may get burnt or cooked badly.

## Accessories

Clean with diluted detergent, soft sponge and water.

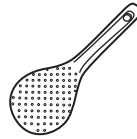

Rice scoop

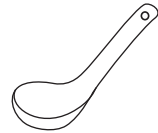

Porridge [Soup] scoop



Measuring cup(1)  
(About 180 mL)

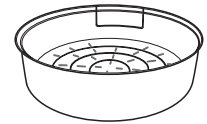

Steaming basket(1)

## Periodic inspection

- Inspect about once a month, and wash immediately if there is dirt.

The bottom of the rice cooker  
(Intake port/exhaust port)

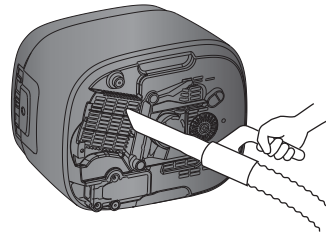

Suck garbage and other foreign objects with a vacuum cleaner.

# Recipes

Note: · The rice may get burnt at the bottom depending on the ingredients added.  
· To use white fungus soup or other ingredients that will get thicker, use the "Congee" function and do not exceed the "Congee" maximum waterline. Otherwise, the soup may overflow.

※1 cup (Measuring cup): approx. 150 g

## Spicy Curry Beef Ribs

Ingredients:	Carrot	150 g	Seasoning:	Oil	15 g
	Potato	300 g		Water	200-300 ml
	Onion	350 g	Group A	Commercially available curry blocks (spicy)	90 g
	Beef ribs	800 g		Satay sauce	20 ml
				Dark soy sauce	30 ml
				Peanut butter	30 ml
				Light soy sauce	30 ml

- Steps: 1) Wash all ingredients, cut carrots, onions and potatoes into chunks, and dry the surface of the beef ribs with kitchen paper.
- 2) Pour oil into a hot pot, and when the oil is hot, turn the heat down and pour in the beef ribs, fry until the beef ribs are lightly browned on both sides, then pour in the onions, and stir fry them.
- 3) Stir fry until onions become soft, then pour in seasonings of group A. Stir fry until there is a nice flavor, then add appropriate amount of water and cook until the water boils.
- 4) Pour the food from the pot into the pan, add potatoes and carrots, and add water until the water is slightly over the ingredients.
- 5) Select the "Strew" function, and set the cooking time to 1 hour 30 minutes.
- 6) After cooking, serve and enjoy.

## Pumpkin Porridge

Ingredients:	Pumpkin	70 g
	Long-grain rice	1 measuring cup

- Steps: 1) Wash and peel the pumpkin, then break it into pieces with a food processor.
- 2) Wash one cup of long grain rice, pour the rice and pumpkin to the pan and add water to the "1" waterline for "Congee".
- 3) Select the "Congee" function, and set the cooking time to 1 hour 30 minutes.
- 4) After cooking, press the "Off/Cancel" key.

## Tomato chicken wings

Ingredients:	chicken wings	8	Seasoning:	Tomato ketchup	10 mL	Soy sauce	15 mL
	Mushrooms	100 g		Oyster oil	10 mL	Water	50 mL
	Tomatoes	2		Salt	2.5 g	Sugar	5 g

- Steps: 1) Score both sides of the wings twice with a knife, peel and dice the tomatoes, wash the shitake mushrooms.
- 2) Put all ingredients and seasoning in the pan then close the outer lid.
- 3) Press the [ < ] or [ > ] key to select "Slow Cook", set the cooking time to 25 minutes, and then press the [Start] key.

# Recipes

## Mushroom soup

Ingredients:	White beech mushroom	70 g	Seasoning:	Salt	Suitable amount
	Crab mushroom	70 g		Ground white pepper	Small amount
	King oyster mushroom	60 g			
	Chopped scallion	Suitable amount			

- Steps:
- 1) Soak the three species of mushrooms in lightly salted water for 10 minutes. Wash them clean, cut off the roots, and cut the king oyster mushrooms into small pieces.
  - 2) Put all the mushrooms into the pan, add water to the "Congee" maximum waterline, and close the outer lid.
  - 3) Press the [ < ] or [ > ] keys, select "Soup", set the cooking time to 1 hour and 30 minutes, and then press the [Start] key.
  - 4) After the cooking is complete, open the outer lid, add a suitable amount of salt, ground white pepper and chopped scallion to taste.
- Note: You can choose your favorite species of mushrooms.

## Cake (Low-gluten flour)

Ingredients:	Low-gluten flour	100 g	Butter	30 g
	Egg	3-4	Milk	25 g
	White sugar	100 g		

- Steps:
- 1) Separate the egg whites and yolks into two bowls (without water or oil), add 20 g of white sugar to the yolks and stir them until smooth and particle-free.
  - 2) Add 80 g of white sugar to the egg whites, beat them with a whisk until the chopsticks can stand upright in the egg whites, add the egg yolks to the egg whites, and stir well left and right.
  - 3) Add the sifted low-gluten flour to the cake batter in batches and stir well until smooth and particle-free.
  - 4) Add melted butter to the cake batter and stir well until smooth and particle-free.
  - 5) Add milk to the cake batter and stir well until smooth and particle-free.
  - 6) Thinly spread butter on the inside of the pan. Pour the cake batter into the pan and close the outer lid.
  - 7) Press the [ < ] or [ > ] keys, select "Cake", set the cooking time to 50 minutes, and then press the [Start] key.
  - 8) When the buzzer sounds, it means that the cake is baked.
  - 9) Press the [Off/Cancel] key, take out the pan and let it cool for 2 minutes. Then reverse the pan to pour the cake onto a plate or disk and let it cool.
- ※ Do not exceed the specified weight of cake batter. Otherwise, the cake may be undercooked.

## Greek thick yogurt

Ingredients:	Yogurt	25 mL
	Milk	125 mL
	White sugar	10 g

- Steps:
- 1) Disinfect glasses and spoons with hot water\* (※ Soak in hot water above 95°C for 5 minutes).
  - 2) Put the yogurt, milk and sugar into the cooled glass and stir them with a spoon.
  - 3) Seal the glass rim with plastic wrap.
  - 4) Put 500 mL of water into the pan, then put the cup in 3), and close the outer lid.
  - 5) Press the [ < ] or [ > ] keys, select "Ferment", set the cooking time to 6 hours, and then press the [Start] key.
  - 6) After the cooking is complete, put gauze in a container with a filter (similar to a coffee cup), pour the prepared yogurt, and put it in the refrigerator for 8 hours to get a mellow and delicious yogurt.

# Troubleshooting

Please check before requesting a repair.

Scenario	Possible Cause	Ref. page
Start cooking as soon as a timer is set	<ul style="list-style-type: none"> <li>● Is the clock accurate? (24 hour display)</li> <li>● Is the preset time not within "Time range to preset"?</li> </ul>	6 8
Does not cook during preset time	<ul style="list-style-type: none"> <li>● Is the current time displayed correctly? (24 hour display)</li> <li>● Check if the [Start] key has been pressed.</li> </ul>	6 11
Cooking time is long	<ul style="list-style-type: none"> <li>● If cooking is done continuously, the cooking time will be longer (by up to 30 minutes).</li> <li>● Due to the different amounts of rice and water, the remaining time displayed may be stopped for adjustment in the middle of cooking.</li> <li>● Is "U12" displayed?</li> </ul>	— — 18
Cooking time is short	<ul style="list-style-type: none"> <li>● Due to the different amounts of rice and water, the remaining time display may be adjusted in the middle of cooking.</li> </ul>	—
The appliance makes a noise	<ul style="list-style-type: none"> <li>● The "pu" sound is the sound given by fan to dissipate the heat during rotation.</li> <li>● The "grumble" sound is the sound given by IH (induction heating) during energizing. Sometimes you may hear these sounds during keep warm.</li> <li>● "xiu" sound is the sound of the steam ejection.</li> </ul>	— — —
Steam vapor leaks from a place other than the steam vent	<ul style="list-style-type: none"> <li>● Is foreign object attached to the pan seal ring of the inner lid and along the pan, or is the pan deformed?</li> <li>● Is the inner lid cleaned and installed correctly after each use?</li> </ul>	— 12
Key operation can not be performed	<ul style="list-style-type: none"> <li>● Check if the lights above the keys are on. →Key operation can not be performed during cooking, while using the timer, or when using the "Keep Warm" function. Press the [Off/Cancel] key before operation.</li> </ul>	—
When a power outage occurs during cooking	<ul style="list-style-type: none"> <li>● The end of cooking may be delayed.</li> <li>● Depending on the length of the power outage, sometimes delicious rice may not be cooked.</li> </ul>	— —
Sparks occur from the power plug	<ul style="list-style-type: none"> <li>● When plugging or pulling the power plug, small sparks may sometimes emerge. This is the inherent characteristics of IH (induction heating) mode, and is not a malfunction.</li> </ul>	—
There is a plastic smell	<ul style="list-style-type: none"> <li>● There may be a plastic smell at the beginning of use. This will be eliminated after several more uses. It is not abnormal.</li> </ul>	—
When the display disappears	<ul style="list-style-type: none"> <li>● Is "8:30" displayed when the power plug is plugged in? [Display] The lithium battery has been exhausted. As long as the power plug is plugged in, you can cook and keep warm, but to use the timer function for cooking, you must check the clock every time. Please replace the new battery at this time. The battery is fixed inside the body, and the customer cannot replace it himself/herself. [No display] The circuit board is faulty. →For battery replacement or fault repair, please contact a Panasonic authorized service center.</li> </ul>	—

## Notice

- If you are careless to put water and rice into the main body without the pan, please consult the Panasonic authorized service center.





# Troubleshooting

It is not a fault, please check it before requesting a repair.

Phenomenon	Possible Cause
Rice is glutinous (soft)	<ul style="list-style-type: none"> <li>● Rice quantity and water volume may be incorrect.</li> <li>● There may be broken rice mixed in.</li> <li>● The rice may have been immersed in water for a long time (e.g. preset time is too long, etc.). →When using the timer function to cook, you need to put less water.</li> <li>● Hot water was used to wash the rice.</li> <li>● The rice was not loosened immediately after cooking.</li> <li>● Too much water was added into new rice for cooking.</li> </ul>
Rice is dry (hard)	<ul style="list-style-type: none"> <li>● Rice quantity and water volume may be incorrect.</li> <li>● Is "Quick/Quinoa" function used to cook?</li> </ul>
Porridge is mushy	<ul style="list-style-type: none"> <li>● The rice was soaked in water for a long time while using the cooking timer function.</li> <li>● The "Keep Warm" function has been used.</li> <li>● There is too much broken rice.</li> </ul>
Rice is scorched	<ul style="list-style-type: none"> <li>● Rice was not washed adequately.</li> <li>● Is there any foreign object at the bottom of the pan, on the bottom sensor and inside the main body?</li> <li>● The cooking timer hasn't been set.</li> <li>● Broken rice has been mixed in.</li> <li>● Spices have been added for cooking.</li> <li>● Yellowish paste formed on the bottom of the pan is not a malfunction. → If it is not improved after the above has been confirmed, refer to "To improve scorched rice". ( P19 ) .</li> </ul>
There is condensation There is odor Rice is yellow	<ul style="list-style-type: none"> <li>● Rice has not been loosened immediately after cooking.</li> <li>● The "keep Warm" function has been used for longer than 5 hours.</li> <li>● Cooled rice has been added into the pan and the "Keep Warm" function has been used.</li> <li>● Rice was not washed adequately.</li> <li>● The rice scoop has been left in the pan while using the "Keep Warm" function.</li> <li>● Different types of rice or water quality may cause cooked rice to be yellowish in colour.</li> <li>● If seasonings are used during cooking, you may notice a smell. → Carefully clean the pan, inner lid after use.</li> </ul>
Rice is dry	<ul style="list-style-type: none"> <li>● The "Keep Warm" function is used for longer than 5 hours.</li> <li>● Rice is reheated several times.</li> <li>● Is rice attached to the pan seal ring of the inner lid and along the pan, or is the pan deformed?</li> </ul>
Rice sticks onto the pan	<ul style="list-style-type: none"> <li>● Due to the different varieties of rice, soft rice might easily stick to the pan.</li> <li>● Is there any foreign objects attached to the vent?</li> </ul>
A thin film is formed	<ul style="list-style-type: none"> <li>● A paper-like film is the result of dry starch dissolution, and it is harmless. If rice is not washed sufficiently prior to cooking, such a film may form.</li> </ul>
Cooked rice has bumpy surface	<ul style="list-style-type: none"> <li>● Did you make the surface of rice smooth before cooking?</li> <li>● The powerful fi repower of IH (induction heating) caused this. This is not an anomaly. Under the following circumstances, rice tends to have uneven surface. <ul style="list-style-type: none"> <li>· When rice has not been sufficiently washed.</li> <li>· When a lot of broken rice is mixed in.</li> <li>· When rice has been broken due to excessive force used to wash it.</li> </ul> </li> </ul>

# Error Codes Indication

Please check before requesting a repair.

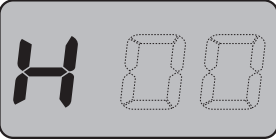
Error display	Please check	Ref. page
	<ul style="list-style-type: none"> <li>● Has the pan being set? → Press the [Off/Cancel] key until the error display disappears. Put the dedicated pan in, and perform the operation Again. (If you don't press the [Off/Cancel] key, the error display will disappear automatically after a moment.)</li> </ul>	—
	<ul style="list-style-type: none"> <li>● Is any foreign object attached to the bottom of the pan or the bottom sensor? → Press the [Off/Cancel] key, unplug the power cord, and remove foreign objects and stains after the pan has cooled down completely.</li> <li>● Has too much water been added? → Press the [Off/Cancel] key. (For continuous cooking, you can slightly reduce the amount of water)</li> </ul>	4 8
	<ul style="list-style-type: none"> <li>● Was the "Keep Warm" duration set to more than 96 hours? → Please press [Off/Cancel] key.</li> </ul>	9
	<ul style="list-style-type: none"> <li>● Has any dust or other foreign object clogged the intake port and the exhaust port at the bottom of the rice cooker? → Remove dust according to the following steps. ① Press the [Off/Cancel] key, and then unplug the power plug. ② Remove the pan until the rice cooker cools down. ③ Clear the dust in the intake port/exhaust port at the bottom of the rice cooker. (  P13)</li> <li>● Is the rice cooker used on the carpet? → Do not use the rice cooker where the bottom of the rice cooker may be clogged.</li> </ul>	— 4
<p>If the appliance is still not back to normal after the above is confirmed, contact a Panasonic authorized service center for repair.</p>		
	<ul style="list-style-type: none"> <li>● Try to unplug the power plug, wait for more than 3 seconds and plug it again. If "H※※" still appears, then there is a fault. → Please consult a Panasonic authorized service center, and advise what the error code says (two digits after "H").</li> </ul>	—

# When you want to improve (optimize)

## Change the temperature of keep warm (default temperature is 74)

When the rice keeping warm has odor, please change to "76", when it changes color or is drying, change to "72". (74→76→72)

1 < > ▶ 2 (Press in order)  
Keep Warm Time Keep Warm

3 Start Reheat Press x 2

4 > ..... 76  
When odor is given

4 > ..... 72  
When rice changes color or becomes dry

The default is "74"

(Setting is automatically done after 10 seconds.)

(Select "Quick/Quinoa", at this time the indicator of the selected function lights up.)

## To improve scorched rice

1 < > ▶ 2 (Press in order)  
Keep Warm Time Keep Warm

3 > >

4 Start Reheat Press x 2

5 >

(Setting is automatically done after 10 seconds.)

(Select "Quick/Quinoa", at this time the indicator of the selected function lights up.)

## To eliminate the beep during cooking, reheat (end the beep)

1 < > ▶ 2 (Press and hold for 5 seconds)  
Keep Warm

(This does not turn off the key tone.)  
Repeat the same step 1 and 2 to turn the beep ON

(Select "Quick/Quinoa", at this time the indicator of the selected function lights up.)

# Specifications

Model No.		SR-HNS151
Rated voltage		230 V $\sim$
Rated frequency		50 Hz
Rated power input		1180 W
Cooking volume(Approx)		1.5 L
Nominal volume of the pan		4.0 L
Cooking quantity (Rice)L [cup]	White Regular	0.18-1.35 [ 1-7.5 ]
	Enhanced Taste	
	Quick	
	Quinoa	0.18 [ 1 ], add 1.5 cups of water
	Short-grain	0.18-1.49 [ 1-8.3 ]
	Brown Rice	0.18-0.9 [ 1-5 ]
	Sticky rice	0.18-0.9 [ 1-5 ]
Porridge cooking volume(Rice)L [cup]		0.09-0.27 [ 0.5-1.5]
Maximum cooking capacity for cuisines (ingredients + water) (approx.) L		1.9 <sup>*1</sup>
Maximum amount of cake batter (approx.) g		700
Power cord length (Approx)m		0.9
Weight (Approx)kg		4.8
Size (Approx)mm	Length	314
	Width	258
	Height	225 (468 <sup>*2</sup> )

- (\*1) The cooking capacity of the maximum waterline of "Congee".
- (\*2) The height when the outer lid is opened.
- Please make sure to use this product in areas under 2000 meters above sea level to avoid affecting cooking performance.

## 使用说明书

家庭用 IH 电磁加热电饭煲

型号 SR-HNS151

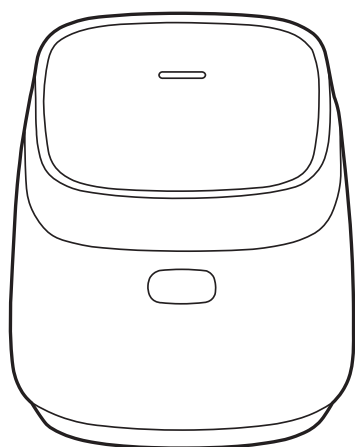

本使用说明书中的图片仅为示意图，  
请以实物为准。

非常感谢您购买Panasonic的产品

- 本产品只限于家庭使用。
- 使用产品前，请仔细阅读本使用说明书，  
以确保正确安全使用本产品。
- 特别要留意【**安全注意事项**】(第22-23页)。
- 请妥善保管本使用说明书，以便日后查阅。

## 目次

<b>安全注意事项</b> .....	22-23
<b>使用注意事项</b> .....	24
<b>零件名称</b>	
● 本体 .....	25
● 操作面板/调整当前时间 .....	26
<b>准 备</b>	
● 洗米、加水 .....	27
● 功能的选择/烹调时间的设定/ 煮出美味米饭的诀窍 .....	28
<b>关于各功能</b>	
● 米饭烹调/保温/冷饭加热 .....	29
● 煮粥·蒸煮·炖汤·卤煮 .....	30
● 蛋糕·发酵/预约功能 .....	31
<b>清洁保养</b> .....	32-33
<b>食谱</b> .....	34-35
<b>故障排除</b> .....	36-37
当出现这样的显示时 .....	38
想要改善时 (优化功能) .....	39
<b>规格</b> .....	40

使用  
前

使用  
方法

困  
惑  
时

# 安全注意事项

请务必遵守!

为防止造成人身伤害、财产损失，请务必遵守以下安全注意事项。

■以下图标表示错误操作可能导致的伤害程度。

 **警告**：表示如不可避免，则可能导致死亡或严重伤害的某种潜在危害情况。

 **注意**：表示如不可避免，则可能导致轻微或中度伤害的某种潜在危害情况。

■符号的分类及解释如下。

 此符号表示不能进行，即“禁止”的内容。

 此符号表示务必执行，即“强制”的内容。

## 警告



### ■电源·电源线·电源插头

- 如电源线或电源插头已损坏或电源插座与电源插头的接口松脱，请勿使用产品。  
(以免导致触电或因短路导致火灾。)  
→如果电源线损坏，必须用专用电源线或从制造厂或维修部买到的专用组件来更换。
- 请勿损坏电源线或电源插头。
  - 绝对禁止进行以下操作：  
损伤、加工、使其接触或靠近高温部、强行弯曲、扭转、拉拔、挂在角上、在其上放置重物、扎成束、夹入、拉动电源线移动。  
(以免因电线和电源插头破损而触电，或因短路导致火灾。)
- 请勿以湿手插入或拔掉电源插头。
  - 接触电源插头或产品前请务必确保手是干燥的。  
(以免导致触电或受伤。)
- 请勿让任何人舔本体插头。  
(以免导致触电或受伤。)
  - 特别要留意婴幼儿。
- 请勿将水或其它液体溅到本体插头上。  
(以免导致触电或因短路导致火灾。)
- 务必要单独使用规格为AC 230 V/10 A的交流电的电源插座。  
(以免与其他电器并用，因发热而引起火灾。)
  - 务必使用规格至少为10 A的接线板。
- 务必要将本体插头、电源插头切实插到底。  
(以免导致冒烟、火灾或触电。)
- 本产品应使用单向两极带接地的电源插座，并保证其可靠接地。未安装接地装置，可能会引起箱体等其他金属部件带有感应静电。  
(以免发生故障或漏电时有触电的危险。)

### ● 定期清洁电源插头。

(以免电源插头因湿气及外物积聚而导致绝缘不良，从而引起火灾。)  
→拔掉电源插头然后使用干布擦拭。

### ■本体

- 请勿在吸气口、排气口或缝隙间插入任何物件。
  - 特别是针及其他金属物件。  
(以免导致触电或异常动作。)
- 请勿将可能堵塞内盖上的孔的物品放入内锅。  
(以免因蒸汽泄漏或烹调物喷出而导致烫伤或受伤。)  
<禁止的烹调例>
  - 将配料和调味料放入塑料袋中等进行加热的烹调方法。
- 请勿自行更改、拆解或修理产品。  
(以免导致火灾、触电或受伤。)  
→如需修理，请与Panasonic授权的服务中心联系咨询。
- 请勿将产品用于使用说明书记载以外的任何用途。  
(否则可能会导致火灾、烧伤、受伤或触电。)
  - 对于使用不当或未能遵守使用说明书而导致的情况，Panasonic将不承担任何责任。
- 请勿淋水、直接用水清洗或把产品浸在水中。  
(以免导致触电或因短路导致火灾。)  
→如水进入产品内，请联络Panasonic授权的服务中心。

## 警告

### ■使用



- 使用中或刚使用后，请勿将脸或手靠近蒸汽口处，对小孩要格外注意。  
(以免导致烫伤。)



- 请勿在烹调时打开外盖或移动本体。  
→如需中途开盖，请务必小心。  
(以免因蒸汽泄漏或烹调物喷出而导致烫伤或受伤。)
- 本产品不适合供下列人士(包括孩童)使用：  
身体官能或心智能力退化者，或是经验与使用知识缺乏者，除非有负责他们安全的人员在旁监督或指导，方可使用。请注意避免让孩童戏玩本产品。  
(以免导致烧伤、受伤或触电。)

- 请务必将产品放置于孩童触碰不到的位置。  
(以免导致烫伤、受伤或触电。)
- 发生异常或故障时，请立即停止使用并拔掉电源插头。  
(以免导致冒烟、火灾或触电。)  
异常·故障例
  - 电源插头及电源线异常发热。
  - 电源线已损坏或碰到电源线后发生间歇性断电。
  - 本体变形或异常发热。
  - 本体冒烟或发出焦味。
  - 本体破裂、松动或发出异响。
  - 烹调时底部风扇不旋转。→请立即与Panasonic授权的服务中心联系，咨询检查及修理事宜。

## 注意



- 请勿使用非专用内锅或变形后的内锅。  
(以免因过热或故障导致烫伤或受伤。)

- 请勿在下记地方使用本产品。
  - 靠近热源或高湿环境中。  
(以免导致触电、漏电或火灾。)
  - 不平稳的台面或不耐热的垫子上。  
(以免导致受伤、烫伤或火灾。)
  - 靠近墙壁或家具等处。  
(以免开盖时碰到，或导致家具等变色、变形及破损。)
  - 铝板或电子垫子上。  
(铝质材料可能会产生热量并导致冒烟或火灾。)

- 搬运本体时，请勿触碰开盖按钮。  
(以免使外盖打开，从而导致受伤。)

- 使用中或烹调刚结束时，请勿触摸高温部。
  - 本体温度很高。特别是内盖、内锅等金属部。  
(以免导致烫伤。)



- 禁止使用非本产品自带的电源线，并禁止把本电源线转用到其他地方。  
(以免发生故障或导致触电、漏电或火灾。)

- 请勿将电源插头暴露在蒸汽中。  
(以免导致触电或因短路导致火灾。)  
→使用有拉桌的橱柜时，请在电源插头不会接触到蒸汽的地方使用产品。

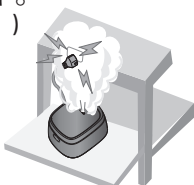

- 请勿空烧。  
(以免导致烫伤。)
- 请勿将本产品外接定时器或在独立的遥控控制系统的方式下运行。  
(以免发生故障，导致受伤。)



- 拔掉电源插头或本体插头时，请确保握住插头本身。  
(以免导致触电，或因短路引起火灾。)
- 取出内锅或不使用时，切记关闭电源并拔下电源插头。  
(以免导致烫伤、受伤或因绝缘老化而引起触电、漏电、火灾。)
- 请等到本体充分冷却后再进行清洗。  
(以免导致烫伤。)
- 在橱柜等封闭空间使用时，请确保蒸汽能向外散发。  
(以免导致橱柜等变色或变形。)
- 如您装有植入式心脏起搏器，使用本产品前请向医生咨询。  
(本产品在工作时可能会对心脏起搏器有影响。)
- 本产品用于家庭和类似用途，例如：
  - 商店、办公室或其他工作环境下的员工厨房区域；
  - 农场住所；
  - 在酒店、旅馆和其他住宅类型的环境中，供顾客使用；
  - 仅提供床位和早餐的类似环境。

### 在使用过程中发生停电时

- 包括在中途拔掉电源插头，跳闸等情况。
- 发生瞬间停电时，会返回停电前的状态。
  - 如果停电时间很长，则重新通电后会出现以下情况。
    - 烹调中：继续烹调。  
可能会影响烹调效果。
    - 保温中：继续保温。

# 使用注意事项

## 关于本体

- 放在滑动式拉桌上时，请务必确认桌子的负荷强度在12 kg以上。  
(以免产品掉落。)

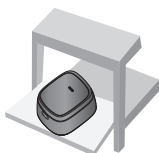

- 使用中请勿将布或其他物品盖在外盖上。  
(以免蒸汽无法释放，导致外盖变形、变色或发生故障。)



- 定期检查电饭煲底部的吸气口及排气口，并清除灰尘。  
(参照P33清洁保养)

- 请及时清理粘在本体上(底传感器、内锅底部、内锅支撑橡胶)的饭粒等异物。  
(以免出现错误显示，或有饭焦、饭烧不熟等情况。)

边缘或底部



(内锅)

内锅支撑橡胶  
(3处)

底传感器

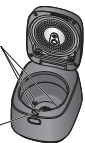

- 请勿将产品放在容易受电磁干扰的装置附近。
  - 无线电、电视、助听器等。  
(以免产生噪音或减低音量。)
  - IC卡、银行卡  
(以免损坏磁性。)

- 请勿将磁铁放在产品附近。  
(以免导致动作异常。)

- 请勿在电磁炉上使用产品。  
(以免损坏电磁炉或导致本产品动作异常。)

- 请勿在户外使用产品。  
(不稳定的电源可能会导致产品发生故障。)

- 请勿在阳光直射下使用。  
(以免导致变色。)

- 请勿在可能会堵塞产品底部(吸气口及排气口)的地方使用电饭煲。  
例如：地毯、塑料袋、铝箔及布料等的上面。  
(以免损坏产品。)

## 关于内锅

- 请勿在电饭煲以外的地方使用内锅。



- 请勿在煤气灶或电磁炉及微波炉内使用。



- 请勿将内锅与硬物撞击。



- (以免导致外层表面刮伤或产生凹痕。)



### 日常使用

- 避免空锅干烧或者长时间放置酸碱性强度的食物。
- 请勿使用金属勺子。(烹调粥等食物)。
- 本产品使用不锈钢内锅，使用过程中会因为水质、高温等情况使内锅表面产生水垢白斑、轻微变色等现象，但不影响健康及使用。

### 烹调结束后



- 请勿轻触或击打内锅。(盛饭时)

### 清洁保养时(P32)

- 请勿将内锅作为洗碗容器。
- 请勿将汤匙或其他餐具放入内锅中。
- 使用调味料烹调后，请勿将食物留在内锅中。  
→ 请尽快清除内锅中的食物然后进行清洗。
- 请勿在清洗后将内锅放在其他餐具上晾干。
- 针对顽固污渍，热水浸泡后再用清洁剂清洗，可使用百洁布辅助清洗，清洗干净后，用干布擦干。



### 提示

以下情况不会影响产品性能或人身健康。  
[外层表面] 浅的刮痕、细小凹痕或碰撞。  
[内层表面] 产生水垢白斑或轻微变色等现象。  
→ 如内锅变形或您担心其状况，请购买新的内锅。

### 不粘锅小提示

- 烹调前，在内锅中加入少量食用油，可以有效减少粘锅现象。
- 根据内锅上的水位线添加米和水，可以有效减少粘锅现象。
- 米饭烹调完成后，尽快食用，长时间保温、二次加热、米饭变凉容易引起粘锅。

# 零件名称

● 首次使用时, 请清洗内锅、内盖、附属品。( P32-33 )

## 本体

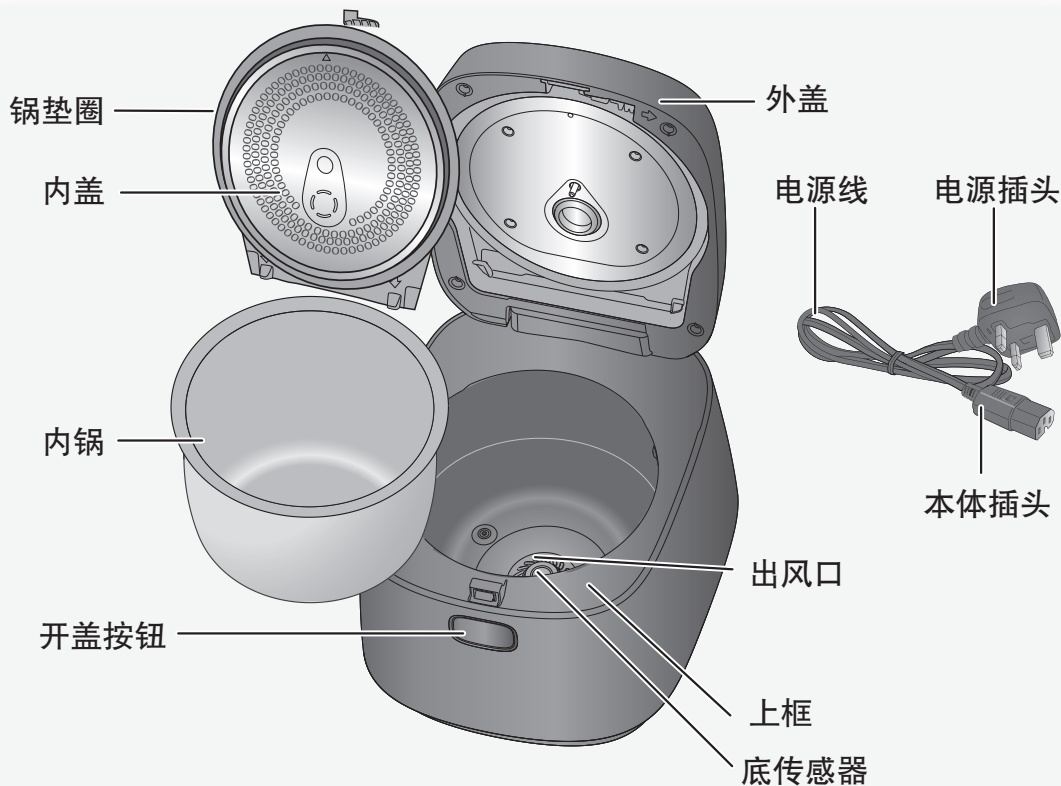
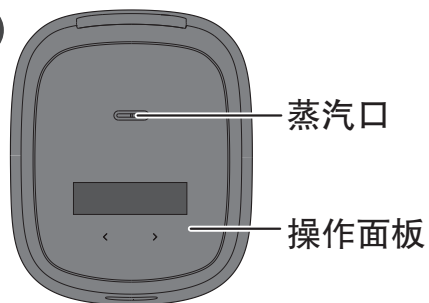

使用前

## 附属品

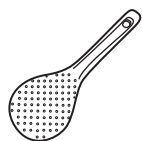

饭勺 (1个)



粥(汤)勺 (1个)



计量杯 (1个)  
(约180 mL)

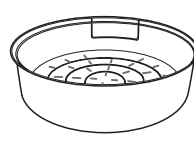

蒸笼 (1个)

# 零件名称/调整当前时间

**操作面板**

**关/取消 按键**

- 可取消不正确的操作，或关闭保温。

**预约 按键**

- 要预约时，按此按键。

**< > 按键**

- 要选择功能时使用。
- 要调整当前时间、设置预约时间和烹调时间时使用。
- 长按按键则可快速前进或后退。

**开/冷饭加热 按键**

- 开始烹调或预约时间设置结束时按此按键。
- 冷饭加热按2次。

**标准煮 按键**

- 要用标准模式烹调短粒米时，按此按键。

**时间 按键**

- 要设置烹调时间时，需先按此按键。
- 要调整时钟时，需长按此按键3秒。
- 要在预约状态下查看烹调时间时，按此按键。

**保温 按键**

- 要保温时，按此按键。

## 调整当前时间

**例：要将上午7:00调到上午8:30时**

①插好电源插头。

②按住「时间」按键,保持3秒钟以上。  
(当听到蜂鸣器发出“哔”的声音时，放开按键)  
液晶显示屏上“分”位数字闪烁，再按一下「时间」按键，  
则“时”位数字闪烁。  
※只能调整闪烁的数字。

③按「<」和「>」按键调整时间。  
每按一次「<」和「>」按键，“分”位时间便以1分钟位单位，  
“时”位数字以1小时位单位增加或减少。  
(时间调整后，数字闪烁几下自动停止，则时间调整完成。)

※工作状态下无法调整时间。  
※长按「<」或「>」按键，则时间可快速前进或后退。  
※时钟为24小时制，24:00以0:00表示。  
※时间显示有误差时，则预约烹调的时间和烹调结束时间均会出现误差，敬请及时调准时间。

# 准备 洗米、加水

## 初次使用前

请先烧开一锅水，再倒掉。

- ①加水至“Long-grain”（长粒米）的最高水位线，闭合外盖。
- ②选择“Steam(蒸煮)”功能，烹调时间设定为15分钟。
- ③蜂鸣器响后，取出内锅，倒掉里面的水。

## 1 用附属的计量杯量米

- 一次可煮的米量，请参考 P40 “规格”。

○正确

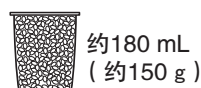

×不正确



## 2 将米洗至水清

- ①加入充分的水，快速搓洗后立即倒掉水。
  - ②轻轻揉搓淘洗后的米，重复数次揉搓→淘洗，直至水清为止。
- 请把米洗干净。否则会有产生锅巴的可能，而且残留的米糠会影响米饭的味道。

①

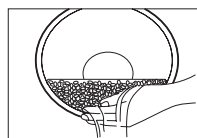

②



## 3 将洗好的米放入内锅

根据需要加水至相应的水位线（请参考 P28），并擦干内锅外表面。

- 煮煮米饭时，请根据米饭种类选择合适的水位线。  
“White Rice”（白米）：适用于外形细长，米粒长度长于 5 mm 的长粒米。  
“Short-grain”（短粒米）：适用于外形短而圆，米粒长度短于 5 mm 的短粒米。
- 放在平坦的台面上加水，并整平米的表面。  
（确认水位线，加水至相同的高度）
- 以上水量可根据个人喜好适当增减。  
（水加得过多时，烹调时可能会沸腾溢出。）

例）烹调4计量杯米时，加水至“Long-grain”（长粒米）的水位线“4”处。

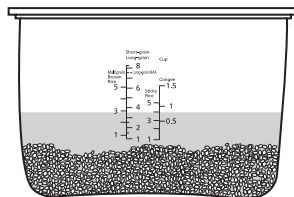

## 4 将内锅放入本体内，闭合外盖

- 闭合外盖时，请确认发出“咔嗒”的闭合音，若未正确安装内盖，则外盖无法闭合。（请参考 P32 内盖）

①

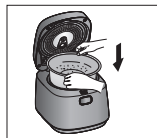

②

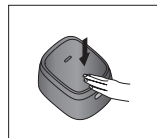

## 5 插上插头

- 请先插上本体插头，再插电源插头，并确保两者均已插到底。

①

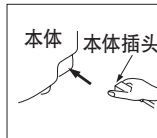

②

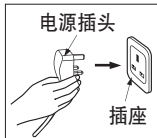

## 注意

在煮饭的同时使用蒸笼蒸煮食物时，白米最大烹调容量：4杯。

# 准备 功能的选择/烹调时间的设定/煮出美味米饭的诀窍

## ■功能的选择

表2

烹调类别	功能选择	水位线	<sup>1</sup> 烹调时间(约)	<sup>2</sup> 保温(自动)	<sup>3</sup> 预约时的可设定范围
烹调白米	White Regular(白米)	Long-grain(长粒米)	37分钟	○	50分钟以上
	Enhanced Taste(精煮)		48分钟	○	60分钟以上
	Quick/Quinoa <sup>4</sup> (超快速/藜麦饭)		27分钟	○	40分钟以上
烹调短粒米	Short-grain(短粒米)	Short-grain(短粒米)	47分钟	○	60分钟以上
烹调粥	Congee(粥)	Congee(粥)	表3	×	烹调时间+1分钟-24小时
烹调糯米饭	Sticky Rice(糯米饭)	Sticky Rice(糯米饭)	37分钟	×	50分钟以上
烹调糙米	Brown Rice(糙米)	Brown Rice(糙米)	1小时30分钟	×	2小时以上
蒸煮	Steam(蒸煮)	蒸煮60分钟以上时 请加4计量杯水	表3	×	烹调时间+20分钟-24小时
发酵	Ferment(发酵)	-		×	-
慢炖	Slow Cook(慢炖)	至“Congee”(粥)的 最大水位线		×	-
蛋糕	Cake(蛋糕)	-		×	-
卤煮	Stew(卤煮)	至“Congee”(粥)的 最大水位线		×	-
炖汤	Soup(炖汤)			×	-
冷饭加热	Reheat(冷饭加热)	参照P29 表4		15分钟	○

\*1 · 在电压为230 V，室温20℃，水温20℃，米量为中间量(4杯)时，烹调所需的参考时间。  
 · 烹调的实际时间会根据米量、水量、电压、室温、水温、米质的不同而变化。  
 · 糯米饭的烹调时间会根据使用的食材而变化。  
 \*2 · 所有功能在烹调结束后都自动转为保温。打“×”的功能不建议保温，烹调结束后请尽快按「关/取消」。  
 \*3 · 炖汤、卤煮、蛋糕、发酵、冷饭加热功能不能预约。  
 · 当设定的预约时间少于烹调时间时，将直接进行烹调。  
 · 夏季等高温天气下，预约时间请勿超过8小时，以免米粒等变质。  
 \*4 · 纯藜麦饭时，只能烹煮1杯，需加1.5杯水(约270 mL)。

## ■烹调时间的设定

表3

烹调类别	功能选择	烹调时间 设定范围	设定单位	初期值	调理时间的显示	调理时间的 记忆
烹调粥	congee(粥)	40分钟-2小时	10分钟	1小时	到2小时后又回到40分钟	○
蒸煮	Steam(蒸煮)	1分钟-60分钟	1分钟	5分钟	到60分钟后又回到1分钟	○
炖汤	Soup(炖汤)	40分钟-2小时	10分钟	1小时	到2小时后又回到40分钟	○
卤煮	Stew(卤煮)	1小时-4小时	10分钟	1小时	到4小时后又回到1小时	○
蛋糕	Cake(蛋糕)	40分钟-60分钟	1分钟	60分钟	到60分钟后又回到40分钟	○
发酵	Ferment(发酵)	30分钟-12小时	30分钟	2小时	到12小时后又回到30分钟	○
慢炖	Slow Cook(慢炖)	1小时-12小时	30分钟	1小时	到12小时后又回到1小时	○

### ★煮出美味米饭的诀窍

① ●正确量水及量米。



② ●轻柔并快速地洗米。  
●勿将米放置在洗米箩内。  
(以免米粒碎裂或米饭粘锅。)



③ ●在平坦的台面加水。  
●勿用热水及pH9以上的碱性水。  
(以免米饭粘锅或变黄。)



# 关于各功能 米饭烹调/保温/冷饭加热

## ※用“Enhanced Taste(精煮)”功能煮饭时

1 按 **<** 或 **>**，选择“Enhanced Taste (精煮)”。

- 所选择的功能闪烁。
- “开”指示灯闪烁。
- 能记忆上一次使用的米饭功能。

2 按 ，烹调开始。

- “开”指示灯点亮。
- 剩余时间以1分钟为单位递减，“Quick/Quinoa(超快速/藜麦饭)”功能在烹调结束前约6分钟开始显示剩余时间。
- 进入焖煮阶段后，会根据饭量的多少自动调整显示的剩余煮饭时间。如：有时可能会从“18分后”一下跳到“15分后”，而不是逐分递减。

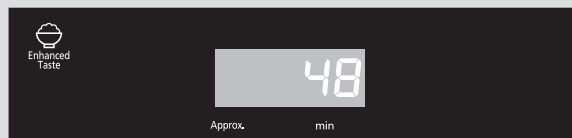



3 烹调结束，翻松米饭。

- 蜂鸣器响后，烹调结束，自动转入保温状态。为防止米饭粘在一起，请尽快翻松米饭。
- 藜麦饭、糙米饭、糯米饭，请尽快按「关/取消」按键，以免影响口感。

### ■温馨提示

- 使用标准模式烹调白米时，按 ，再按「开」。
- 用“Quick/Quinoa(超快速/藜麦饭)”煮饭时，因时间缩短，米饭会稍硬或有锅巴产生。  
→ 预先将米浸泡在水中，则可以使煮好的米饭变软。
- 用“Enhanced Taste(精煮)”功能会使米饭更松软可口。
- 请不要将糙米与白米（短粒米、长粒米）混合煮饭，以免影响煮饭效果。

### 保 温

- 保温时间显示从  到  共24小时，超过24小时后，显示当前时间但仍然继续保温。  
1小时以内时，显示  小时。
- 保温超过96小时，保温将自动停止，显示屏显示“U14”，要继续使用时，请先按「关/取消」按键。
- 米饭以在保温5小时以内食用为佳，以免米饭变色或变味。
- 保温时，内锅的边缘部有时会出现少量水珠。
- 保温时内锅中如放有饭勺等盛饭用具则会影响米饭的味道。

## ※冷饭加热时

准备 ● 请将锅内的冷饭搅拌均匀，使之平整。  
● 冷饭加热时，请参照下记水量表的标准加水。

表4

冷饭量 (水位线)	水量 ( 计量杯 )
0.5	-
1	-
2	1/2
3	1/2
4	1

■冷饭加热的最大量：长粒米4水位线。

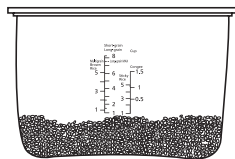

1 按两下 ，烹调开始。

- “开”指示灯点亮。
- 不管冷饭量多少，加热时间都约15分钟。



2 蜂鸣器响后，烹调结束，自动转入保温状态。

- 请尽快翻松米饭，米饭将更美味。

### ■温馨提示

- 加入冷饭时，请不要超出最大冷饭量(如表4所示)。
- 建议冷饭加热的次数为一次，以免影响米饭的口感。
- 请不要加热糯米饭、糙米饭、藜麦饭，以免影响口感。

## ※用1.5小时烹调粥时

1 按 **<** 或 **>**，选择“Congee(粥)”。

- 所选择的功能闪烁。
- “开”指示灯闪烁。

2 按 **Time**，再按 **<** 或 **>**，设定烹调时间。

- 长按「<」或「>」按钮，时间可快速前进或后退。
  - 能记忆上一次的烹调时间。
- ※ 烹调时间的可设定范围  P28表3。

3 按 ，烹调开始。

- “开”指示灯点亮。
- 剩余时间以1分钟为单位递减。

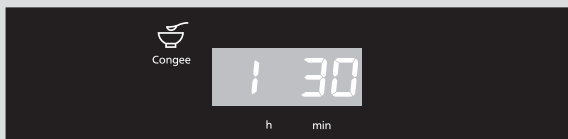

4 蜂鸣器响后，烹调结束，自动转入保温状态。

- 为避免因保温而影响口感，请尽快按「关/取消」按键。

### ■温馨提示

- 烹调中打开外盖，会增加结露量。
- 水量、米量不正确，可能会导致米汤从蒸汽口中溢出。
- 如保温时间过长，粥将会变稠。
- 炖汤时，如超过“Congee”(粥)的最大水位线，可能会造成溢出。(  P40规格)
- 每次使用完毕后，应取下内盖冲洗，以免产生异味。

## ※要蒸煮10分钟时

准备 ①向锅内放入适量的水。  
②放入蒸笼。  
③放入需蒸煮的食物。  
④闭合外盖。

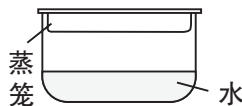

1 按 **<** 或 **>**，选择“Steam(蒸煮)”。

- 所选择的功能闪烁。
- “开”指示灯闪烁。

2 按 **Time**，再按 **<** 或 **>**，设定烹调时间。

- 长按「<」或「>」按钮，时间可快速前进或后退。
  - 能记忆上一次的烹调时间。
- ※ 烹调时间的可设定范围  P28表3。

3 按 ，烹调开始。

- 水沸腾后，剩余时间以1分钟为单位递减。
- 显示屏内显示的时间为内锅中的水沸腾后的剩余时间。



4 蜂鸣器响后，烹调结束，自动转入保温状态。

- 为避免因保温而影响口感，请尽快按「关/取消」按键。  
此时，蒸笼变的非常烫，取出时请务必当心烫手。

### ■温馨提示

- 如选择了较长的蒸煮时间(如蒸60分钟以上)，加水4计量杯，以免水被蒸干。

# 关于各功能 蛋糕·发酵 / 预约功能

## ※用“Cake(蛋糕)”功能烘烤蛋糕(50分钟)时准备

- 按照蛋糕粉的要求，将所有食材搅拌均匀。
- 在内锅壁上涂一层黄油(或食用油)，然后将搅拌好的蛋糕糊倒入内锅并闭合外盖。

1 按<或>，选择“Cake(蛋糕)”。

2 按Time，再按<或>，设定烹调时间。

※烹调时间的可设定范围 P28表3。

3 按 ，烹调开始。

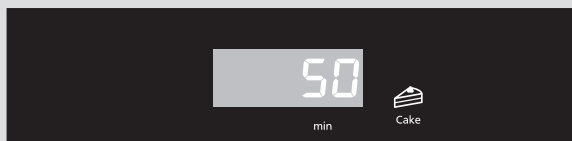

4 蜂鸣器响后，烹调结束，自动转入保温状态。

- 为避免因保温而影响口感，请尽快按「关/取消」按键。
- 取出内锅并冷却几分钟，然后倒扣内锅，倒出蛋糕即可食用。取出内锅时，请小心烫手。

### ■温馨提示

- 蛋糕糊的最大量：700 g (蛋糕粉、牛奶、鸡蛋等的总重量)，超过此量可能会导致蛋糕烘烤不熟。
- 除了蛋糕粉，还可以用普通的低筋粉做蛋糕，食谱 P35。
- 烘烤大量的蛋糕糊时，烹调时间请设定为60分钟，以免蛋糕不熟。
- 发酵前请先将内锅、容器进行消毒，以免发酵失败。

## ※用“Timer<sup>1</sup>”功能在11:30完成“短粒米”的“Enhanced Taste(精煮)”时

- 首先确认当前时间是否正确。如果不正确，请调整到正确时间。(P26)

1 按P29~P30的方法选择功能。

- 所选择的功能闪烁。
- “开”指示灯闪烁。

2 按 ，选择“Timer<sup>1</sup>”。

- 预约煮粥时，先按P30步骤2设定烹调时间，再按「预约」按键。
- 本产品可以设定两个不同的预约时间(如早饭和晚饭)，每按一次「预约」按键，

Timer<sup>1</sup> → Timer<sup>2</sup> → Timer<sup>1</sup>将交替显示。

3 按<或>，设定预约时间。

- 长按「<」或「>」按钮，时间可快速前进或后退。
- 当设定的预约时间少于烹调时间时，将直接进行烹调。

※可以预约的功能和时间范围 P28表2。

4 按 ，预约烹调开始。

- “开”指示灯熄灭，“预约”指示灯点亮，预约设定完成。
- 预约状态下确认煮粥时间时，请按「时间」按键。
- 查看当前时间时，请按「预约」按键。



### ■温馨提示

- 烹调糯米饭时，请勿使用预约功能，以免食材变质或影响性能。
- 夏季等高温天气下，预约时间请勿超过8小时，以免米粒等变质。
- 预约功能设定的时间为烹调结束的时间。
- 能记忆上一次的预约时间及烹调时间。

# 清洁保养

## 注意

- 清洁前，务必拔掉电源插头，等本体冷却后再进行清洗。
- 清洁时，切勿将本体浸入水中，不要使用香蕉水，汽油、酒精，去污粉，硬质刷等擦拭。

## 内盖/锅垫圈

使用厨房专用中性清洗剂清洗。

### ■ 拆除时

- ① 向右移动内盖拆装拨杆。  
(内盖会向前面方向倾倒。)
- ② 取出。

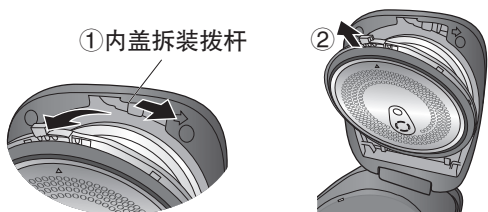

### ■ 安装时

- ① 将内盖插入槽位内。(两侧)
- ② 向外盖按入，直至听到“咔哒”一声

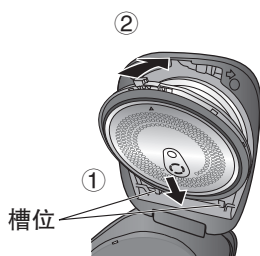

### 提示

- 请勿拉扯垫圈。
- 每次烹调完后，应取下内盖进行冲洗。  
(以免产生异味。)
- 使用调味料后，请及时清洗。  
(以免产生异味、变质或锈蚀。)

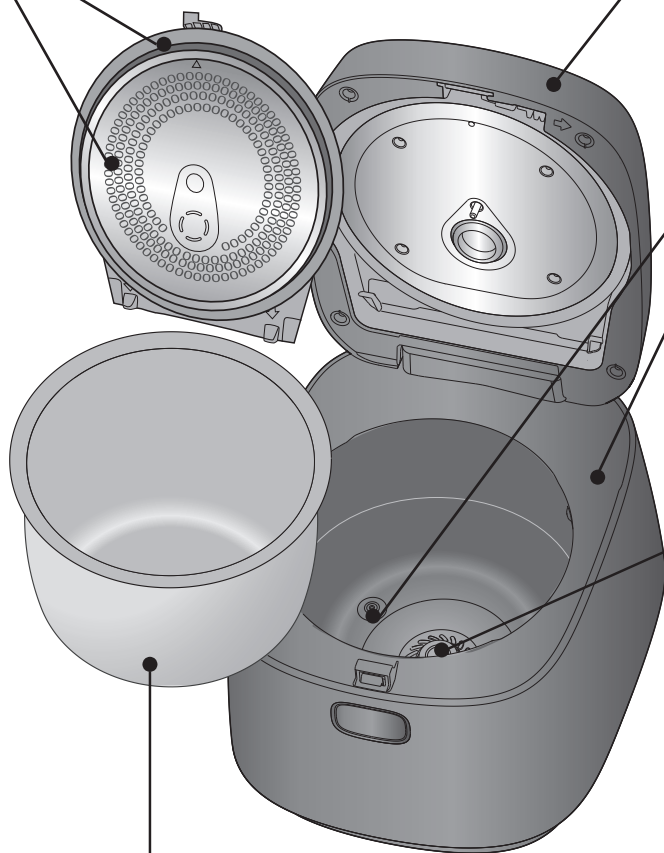

## 内 锅

- 针对顽固污渍，可使用热水浸泡后再用清洁剂清洗，可使用百洁布辅助清洗，清洗干净后，用干布擦干。
- 若内锅内壁有白色斑点或发黄，用少许食用醋或柠檬片擦拭；若出现彩虹色斑点，可用食用醋或可乐擦拭，擦拭后需冲净并擦干。

# 清洁保养

## 外盖内表面

用拧干的湿毛巾擦拭。

- 擦拭外盖内表面。

## 上框 / 内锅支撑橡胶 (3处)

用拧干的湿毛巾擦拭。

### 提示

- 请勿将水倒入进行清洗。

## 底传感器

用拧干的湿毛巾擦拭。

- 如污垢很难清除，用少量厨房专用中性洗涤剂，再用尼龙刷轻轻擦拭。

### 提示

- 如果不擦干净底传感器，则米饭可能会被烧焦，煮不好。

## 附属品

用稀释后的餐具清洗剂和海绵清洗

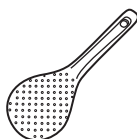

饭勺



粥(汤)勺



计量杯 (1个)  
(约180 mL)

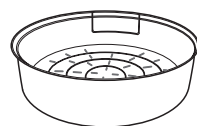

蒸笼 (1个)

## 定期检查

- 大约每月检查一次，如有污垢请及时清除。

### 产品底部

(吸气口/排气口)

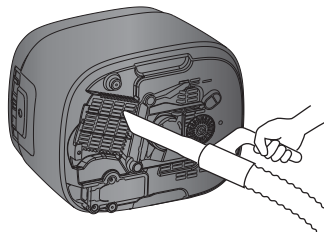

用吸尘器吸除垃圾及异物等。

# 食谱

注意：·根据加入米饭内的食材不同，饭的底部可能有烧焦的现象。  
·煮银耳汤等会变浓稠的食材时，请使用“Congee(粥)”功能，最大烹调量至“Congee”最高水位线，以免溢出。

※1杯(计量杯)：约150g

## 辣咖喱牛肋排

食材：胡萝卜	150 g	调味料：油	15 g
土豆	300 g	水	200-300 ml
洋葱	350 g	A组 { 市售咖喱块 (辣味) 90 g 沙茶酱 20 ml 老抽 30 ml 花生酱 30 ml 生抽 30 ml	
牛肋排	800 g		

- 做法：1) 洗净所有食材，胡萝卜、洋葱、土豆切块，牛肋排用厨房纸擦干表面水分。  
2) 热锅倒入油，油热后转小火倒入牛肋排，煎至两面微微焦黄后，倒入洋葱翻炒。  
3) 洋葱炒软后，倒入A组调料，炒香调料后加入适量水，煮至水开。  
4) 将锅中食物倒入内锅，加入土豆、胡萝卜，加水至微微没过食材。  
5) 选择“Stew(卤煮)”功能，设定烹调时间为1小时30分钟。  
6) 烹调结束后，盛出即可食用。

## 金瓜粥

食材：金瓜(南瓜)	70 g
长粒米	1计量杯

- 做法：1) 金瓜洗净去皮后，用料理机打碎。  
2) 淘洗一杯长粒米，同金瓜一起倒入内锅，并加水至“Congee(粥)”的“1”刻度线处。  
3) 选择“粥”功能，设定烹调时间1小时30分钟。  
4) 烹调结束，按“关/取消”按键。

## 番茄鸡翅

食材：鸡翅	8个	调味料：番茄酱	10 mL	酱油	15mL
香菇	100 g	蚝油	10 mL	水	50 mL
番茄	2个	盐	2.5 g	糖	5 g

- 做法：1) 将鸡翅两面划两刀，番茄去皮切丁，香菇洗净。  
2) 将所有食材和调味料放入内锅，闭合外盖。  
3) 按「<」和「>」按键，选择“Slow Cook(慢炖)”，烹调时间设定为25分钟，再按下「开」按键。

## 菌菇汤

食材：白玉菇	70 g	调味料：盐	适量
蟹味菇	70 g	白胡椒粉	少许
杏鲍菇	60 g		
葱花	适量		

- 做法：1) 三种菌菇在加了适量盐的淡盐水中浸泡10分钟，洗净，切去根部，杏鲍菇切小段。  
2) 将所有菌菇放入内锅，加水至“粥”的最大水位线，并闭合外盖。  
3) 按「<」和「>」按键，选择“Soup(炖汤)”，烹调时间设定为1小时30分钟，再按下「开」按键。  
4) 烹调结束后，打开外盖，加入适量盐、白胡椒粉及葱花调味即可。  
注：菌菇可选用自己喜欢的种类。

## 蛋糕（低筋粉版）

食材：低筋面粉	100 g	黄油	30 g
鸡蛋	3-4 个	牛奶	25 g
白糖	100 g		

- 做法：1) 将鸡蛋的蛋清和蛋黄分开到两个盆中(无水无油)，在蛋黄中加入20 g白糖，把白糖和蛋黄搅拌均匀至顺滑无颗粒。  
2) 在蛋清中加入白糖80 g，用打蛋器打发至筷子可以直立在蛋清中不倒，将蛋黄加入到蛋清中，左右搅拌均匀。  
3) 分次在蛋糕糊中加入过筛的低筋面粉，搅拌均匀至顺滑无颗粒。  
4) 在蛋糕糊中加入融化的黄油搅拌至顺滑无颗粒。  
5) 在蛋糕糊中加入牛奶搅拌均匀至顺滑无颗粒。  
6) 将蛋糕糊倒入内锅，闭合外盖。  
7) 按「<」和「>」按键，选择“Cake(蛋糕)”，烹调时间设定为50分钟，再按下「开」按键。  
8) 蜂鸣器响后，表示蛋糕已经烤熟。  
9) 按「关/取消」按键，从电饭煲取出内锅并冷却2分钟，再倒转内锅把蛋糕倒入盘中或碟上，等它冷却后即可切开享用。  
※请注意不要倒入超过指定重量的蛋糕糊，否则蛋糕会烘烤不熟。

## 希腊厚酸奶

食材：酸奶	25 mL
牛奶	125 mL
白糖	10 g

- 做法：1) 将玻璃杯、勺子用热水消毒\*（※用95℃以上的水泡5分钟）。  
2) 将酸奶、牛奶、白糖放入冷却后的玻璃杯，用勺子充分搅拌。  
3) 用保鲜膜将玻璃杯口密封。  
4) 将内锅放入500 mL水，再放入3)的杯子，并闭合外盖。  
5) 按「<」和「>」按键，选择“Ferment(发酵)”，烹调时间设定为6小时，再按下「开」按键。  
6) 烹调结束后，将纱布铺在带过滤口的容器（类似咖啡漏杯）里面，倒入制作好的酸奶，放入冰箱静置8小时即可得到醇厚可口的酸奶。

# 故障排除

在委托维修之前请先进行检查。

现象	请检查	参考页码
一开始预约就开始烹调	<ul style="list-style-type: none"><li>● 时钟是否准确？（24小时制显示）</li><li>● 预约时间是否在“预约时的可设定范围”之外。</li></ul>	26 28
不在预约时间烹调	<ul style="list-style-type: none"><li>● 当前时间显示是否正确？（24小时制显示）</li><li>● 是否已按了「开」按键？</li></ul>	26 31
烹调时间长	<ul style="list-style-type: none"><li>● 如果连续烹调，则烹调时间将会变长。（最多可能会延长30分钟左右）</li><li>● 因米饭量和水量不同，在烹调中途，可能会停止剩余时间显示并进行调整。</li><li>● 是否显示“U12”？</li></ul>	— — 38
烹调时间短	<ul style="list-style-type: none"><li>● 可能会因米饭量和水量不同，在烹调途中调整剩余时间显示。</li></ul>	—
发出声音	<ul style="list-style-type: none"><li>● “卍”音…是风扇驱散热量的转动声音。</li><li>● “叽”音…是IH（电磁加热）的通电声音。保温中有时会听到这样的声音。</li><li>● “咻”音…是蒸汽喷出的声音。</li></ul>	— — —
蒸汽从蒸汽口以外的部位漏出	<ul style="list-style-type: none"><li>● 内盖的锅垫圈部和内锅的锅沿上是否附有异物，或内锅是否已变形？</li><li>● 内盖是否每次使用后都进行清洗，并正确安装？</li></ul>	— 32
不能进行按键操作	<ul style="list-style-type: none"><li>● 按键的指示灯是否点亮着？ →烹调、预约、保温中途，无法进行按键操作。 请按「关/取消」按键后再进行操作。</li></ul>	—
在烹调中发生停电时	<ul style="list-style-type: none"><li>● 烹调结束的时间可能会延后。</li><li>● 根据停电时间长短的不同，有时可能会煮不出美味可口的米饭。</li></ul>	— —
从电源插头冒出火花	<ul style="list-style-type: none"><li>● 在插、拔电源插头时，有时可能会冒出小火花。这是IH（电磁加热）方式固有的特点，不是故障。</li></ul>	—
有塑料异味	<ul style="list-style-type: none"><li>● 刚开始使用时可能会有塑料的味道，多使用几次后便会消除，不是异常。</li></ul>	—
当显示消失	<ul style="list-style-type: none"><li>● 插入电源插头时，是否显示“8：30”？ [显示] 锂电池已耗尽。 只要插入电源插头就可以进行烹调及保温操作，但想要预约烹调时，每次必须进行时钟的核对。此时请更换新电池。 电池固定于本体内部，客户自己无法进行更换。 [不显示] 电路板发生故障。 →电池的更换或故障的修理，请联系Panasonic授权的服务中心。</li></ul>	—

## 须知

- 不小心误将水和大米直接倒入未放置内锅的本体时，请联系Panasonic授权的服务中心。

# 故障排除

并非故障，在委托维修之前请先进行检查。

现象	原因
发粘（较软）	<ul style="list-style-type: none"><li>●米量和水量是否正确？</li><li>●是否混入较多碎米？</li><li>●是否长时间浸泡水中？（预约时间太长等） →使用预约功能烹调时，需少放些水。</li><li>●是否使用热水洗米？</li><li>●煮好后，是否立即将米饭翻松？</li><li>●新米是否放入较多水进行烹调？</li></ul>
发干（较硬）	<ul style="list-style-type: none"><li>●米量和水量是否正确？</li><li>●是否用“Quick/Quinoa(超快速/藜麦饭)”功能进行烹调？</li></ul>
粥变糊状	<ul style="list-style-type: none"><li>●预约定时烹调时，是否让米长时间浸泡于水中？</li><li>●是否对粥进行了保温？</li><li>●是否碎米太多？</li></ul>
饭烧焦	<ul style="list-style-type: none"><li>●洗米是否充分？</li><li>●内锅底部、底传感器及本体内部是否附有异物？</li><li>●是否进行了预约定时烹调？</li><li>●是否混入较多碎米？</li><li>●是否放入调料进行烹调？</li><li>●锅底形成的淡黄色的糊焦，不是故障。 →确认上述内容后仍未改善，请参考“如要改善饭焦”（P39）。</li></ul>
结露 有气味 带黄色	<ul style="list-style-type: none"><li>●煮好后，是否立即将米饭翻松？</li><li>●是否保温超过5小时？</li><li>●是否把冷饭添加到内锅里并进行了保温？</li><li>●洗米是否充分？</li><li>●是否在放入饭勺的状态下进行了保温？</li><li>●因米的种类或所用水质的不同，煮熟的饭可能会带黄色。</li><li>●在放入调料烹调后，可能有气味。 →请仔细清洗内锅、内盖。</li></ul>
米饭干燥	<ul style="list-style-type: none"><li>●是否保温超过5小时？</li><li>●是否反复加热冷饭？</li><li>●内盖的锅垫圈部和内锅的锅沿上是否附有米饭，或内锅是否已变形？</li></ul>
米饭粘在内锅上	<ul style="list-style-type: none"><li>●因大米品种不同，柔软的米饭和粘性好的米饭可能会容易粘锅。</li><li>●出风口是否有异物附着？</li></ul>
形成一层薄膜	<ul style="list-style-type: none"><li>●是否残留着糠皮？ 糯米纸状的薄膜是由于淀粉溶解后干燥所生成的，对人体无害，米没有洗干净则容易生成这种薄膜。</li></ul>
煮好的米饭表面 凹凸不平	<ul style="list-style-type: none"><li>●是否在煮饭前未将米的表面整平？</li><li>●是IH（电磁加热）特有的强大火力造成的。不是异常现象。 下记情况下，容易变得凹凸不平。<ul style="list-style-type: none"><li>·淘米不充分时。</li><li>·混有许多碎米时。</li><li>·由于洗米时用力过大，米粒已经破碎。</li></ul></li></ul>

# 当出现这样的显示时

在委托维修之前请先进行检查。

错误显示	请检查	参考页码
	<ul style="list-style-type: none"> <li>● 是否已将内锅放入？ → 请按「关/取消」按键，待错误显示消失后，放入专用的内锅，再次进行操作。 (若不按「关/取消」，稍等片刻后会自动消失)</li> </ul>	—
	<ul style="list-style-type: none"> <li>● 锅底或底传感器上是否附有异物？ → 请清除异物及污渍，然后按「关/取消」按键。</li> <li>● 水量是否太多？ → 请按「关/取消」按键。 (连续烹调时，可稍微减少一些水)</li> </ul>	24 28
	<ul style="list-style-type: none"> <li>● 保温时间是否在96小时以上？ → 请按「关/取消」按键。</li> </ul>	29
	<ul style="list-style-type: none"> <li>● 电饭煲底部的吸气口及排气口是否有灰尘等异物阻塞？ → 请按下記步骤清除灰尘。 ① 按「关/取消」按键，然后拔掉电源插头。 ② 待电饭煲冷却后，取出内锅。 ③ 清除电饭煲底部的吸气口/排气口中的灰尘。( P33 )</li> <li>● 电饭煲是否有在地毯等物品上使用？ → 请勿在可能会堵塞电饭煲底部的地方使用电饭煲。</li> </ul>	— 24
<p>当进行了上述处理后仍不能恢复正常时，请联系Panasonic授权的服务中心修理。</p>		
	<ul style="list-style-type: none"> <li>● 尝试拔下电源插头，等待3秒以上，再重新插入。 如仍出现“H※※”，则表示存在故障。 → 请联系Panasonic授权的服务中心，并告知错误代码（“H”后的两位数字）。</li> </ul>	—

# 想要改善时（优化功能）

## ■ 如要变更保温温度（默认的保温温度为74）

当保温的米饭发出气味时请变更为“76”，变色或干燥时请变更为“72”。（74→76→72）

1 < > ▶ 2 (依次按) Keep Warm Time Keep Warm 3 Start Reheat Press x 2 4 > ..... 76 发出气味时 4 > ..... 72 变色或干燥时

默认为“74”

(10秒后, 设定自动完成。)

(选择“Quick/Quinoa(超快速/藜麦饭)”，此时选中的功能闪烁)

## ■ 如要改善饭焦

1 < > ▶ 2 (依次按) Keep Warm Time Keep Warm 3 > > 4 Start Reheat Press x 2 5 > >

(选择“Quick/Quinoa(超快速/藜麦饭)”，此时选中的功能闪烁)

(10秒后, 设定自动完成。)

## ■ 如要在烹调、冷饭加热时消除蜂鸣声(结束提示音)

1 < > ▶ 2 (长按约5秒) Keep Warm

(此操作不会关掉按键音。) 重复步骤1和2打开蜂鸣器

(选择“Quick/Quinoa(超快速/藜麦饭)”，此时选中的功能闪烁)

# 规格

型号		SR-HNS151
额定电压		230 V~
额定频率		50 Hz
额定输入功率		1180 W
烹调额定容积(约)		1.5 L
内锅的额定容积		4.0 L
煮饭容量 (米量) L [杯]	White Regular (白米)	0.18-1.35 [ 1-7.5 ]
	Enhanced Taste (精煮)	
	Quick (超快速)	
	Quinoa (藜麦饭)	0.18 [ 1 ], 加水1.5杯
	Short-grain (短粒米)	0.18-1.49 [ 1-8.3 ]
	Brown Rice (糙米)	0.18-0.9 [ 1-5 ]
	Sticky rice (糯米饭)	0.18-0.9 [ 1-5 ]
煮粥容量 (米量) L [杯]		0.09-0.27 [ 0.5-1.5 ]
料理类最大烹调容量 (食材+水) (约) L		1.9*1
蛋糕糊的最大量 (约) g		700
电源线长度 (约) m		0.9
产品重量 (约) kg		4.8
外形尺寸 (约) mm	长	314
	宽	258
	高	225 ( 468*2 )

- (※1) 为“Congee” (粥) 最大水位线的烹调容量。
- (※2) 为打开外盖时的高度。
- 请勿在海拔2000米以上的地区使用本产品, 以免影响烹调效果。