

Panasonic®

Basic Operating Instructions

4K Video Camera

Model No. **HC-X1**

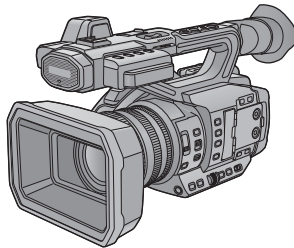

More detailed operating instructions are available in "Operating Instructions (PDF format)". To read it, download it from the website.

<https://www.pavc.panasonic.co.jp/hdw/oi/HC-X1/>

- Click the desired language.

* You will need Adobe Reader to browse or print the Operating Instructions (PDF format).

You can download and install a version of Adobe Reader that you can use with your OS from the following website. (As of November 2016)

<http://www.adobe.com/products/acrobat/readstep2.html>

Please read these instructions carefully before using this product, and save this manual for future use.

AVCHD™
Progressive

HDMI

SDXC™
U3
I

DOLBY
DIGITAL

LEICA
DICOMAR

DVQX1102YA

F1116YF1078

Information for Your Safety



For the AC mains plug of three pins

■ Caution for AC mains lead

For your safety, please read the following text carefully.

This appliance is supplied with a moulded three pin mains plug for your safety and convenience. A 5-ampere fuse is fitted in this plug.

Should the fuse need to be replaced please ensure that the replacement fuse has a rating of 5-ampere and that it is approved by ASTA or BSI to BS1362.

Check for the ASTA mark  or the BSI mark  on the body of the fuse.

If the plug contains a removable fuse cover you must ensure that it is refitted when the fuse is replaced.

If you lose the fuse cover the plug must not be used until a replacement cover is obtained.

A replacement fuse cover can be purchased from your local dealer.

Before use

Remove the connector cover.

How to replace the fuse

The location of the fuse differ according to the type of AC mains plug (figures A and B). Confirm the AC mains plug fitted and follow the instructions below.

Illustrations may differ from actual AC mains plug.

1. Open the fuse cover with a screwdriver.

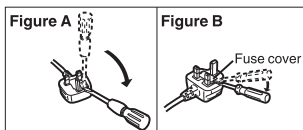

2. Replace the fuse and close or attach the fuse cover.

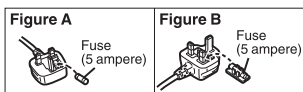

WARNING:

To reduce the risk of fire, electric shock or product damage,

- Do not expose this unit to rain, moisture, dripping or splashing.
- Do not place objects filled with liquids, such as vases, on this unit.
- Use only the recommended accessories.
- Do not remove covers.
- Do not repair this unit by yourself. Refer servicing to qualified service personnel.

CAUTION!

To reduce the risk of fire, electric shock or product damage,

- Do not install or place this unit in a bookcase, built-in cabinet or in another confined space. Ensure this unit is well ventilated.
- Do not obstruct this unit's ventilation openings with newspapers, tablecloths, curtains, and similar items.
- Do not place sources of naked flames, such as lighted candles, on this unit.

The mains plug is the disconnecting device. Install this unit so that the mains plug can be unplugged from the socket outlet immediately.

This unit is intended for use in moderate climates. (HC-X1E)

This unit is intended for use in moderate and tropical climates. (HC-X1GC)

■ Concerning the battery

Warning

Risk of fire, explosion and burns. Do not disassemble, heat above 60 °C or incinerate.

CAUTION

- Danger of explosion if battery is incorrectly replaced. Replace only with the type recommended by the manufacturer.
- When disposing of the batteries, please contact your local authorities or dealer and ask for the correct method of disposal.

For Europe only

■ EMC Electric and magnetic compatibility

This symbol (CE) is located on the rating plate.

■ Product identification marking

| Product | Location |
|-----------------|----------|
| 4K Video Camera | Bottom |
| Battery charger | Bottom |
| AC adaptor | Bottom |

■ Disposal of Old Equipment and Batteries Only for European Union and countries with recycling systems



These symbols on the products, packaging, and/or accompanying documents mean that used electrical and electronic products and batteries must not be mixed with general household waste.

For proper treatment, recovery and recycling of old products and used batteries, please take them to applicable collection points in accordance with your national legislation.

By disposing of them correctly, you will help to save valuable resources and

prevent any potential negative effects on human health and the environment. For more information about collection and recycling, please contact your local municipality.

Penalties may be applicable for incorrect disposal of this waste, in accordance with national legislation.



Note for the battery symbol (bottom symbol):

This symbol might be used in combination with a chemical symbol. In this case it complies with the requirement set by the

Directive for the chemical involved.

AEEE Yönetmeliğine Uygundur.

AEEE Complies with Directive of Turkey.

Note regarding the Power Management function specified under COMMISSION REGULATION (EC) No 1275/2008 implementing Directive 2009/125/EC of the European Parliament and of the Council.

This device is designed and manufactured for use at a broadcasting station and/or in a similar environment.

This device is not equipped with a Power Management function or the Power Management function is set to OFF as it will prevent the device from fulfilling its intended purpose for the reasons below.

1. If the device is a Studio Camera, a Weather Camera, a Mixer or other processor: A Power Management function may cause the device to suddenly stop during recording or while On Air.
2. If the device is a Studio Monitor: A Power Management function may cause video for the confirmation of whether a signal is normal, or whether the signal has been lost, to be unviewable.
3. If the device is a Camera Recorder: A professional camera recorder must be able to start quickly at any time, but a Power Management function will cause an increase in the time taken to resume from Stand-by mode.

■ Cautions for use

About this unit

The unit and the SD card become warm during use. This is not a malfunction.

Keep this unit as far away as possible from electromagnetic equipment (such as microwave ovens, TVs, video games etc.).

- If you use this unit on top of or near a TV, the pictures and/or sound on this unit may be disrupted by electromagnetic wave radiation.
- Do not use this unit near cell phones because doing so may result in noise adversely affecting the pictures and/or sound.

- Recorded data may be damaged, or pictures may be distorted, by strong magnetic fields created by speakers or large motors.
- Electromagnetic wave radiation generated by microprocessors may adversely affect this unit, disturbing the pictures and/or sound.
- If this unit is adversely affected by electromagnetic equipment and stops functioning properly, turn this unit off and remove the battery or disconnect AC adaptor. Then reinsert the battery or reconnect AC adaptor and turn this unit on.

Do not use this unit near radio transmitters or high-voltage lines.

- If you record near radio transmitters or high-voltage lines, the recorded pictures and/or sound may be adversely affected.

About connecting to a PC

- A USB 3.0 cable is not supplied with this unit. Use a commercially-available double-shielded USB 3.0 cable with a ferrite core. If possible, we recommend using a cable with a length of 1.5 m or less.

About using a headphone

- Excessive sound pressure from earphones and headphones can cause hearing loss.
- Listening at full volume for long periods may damage the user's ears.

Make sure to use the supplied cords and cables. If you use optional accessories, use the cords and the cables supplied with them. Do not extend the cords and the cables.

Do not spray insecticides or volatile chemicals onto the unit.

- If the unit is sprayed with such chemicals, its body may be marred and the surface finish may peel off.
- Do not leave rubber or plastic products in contact with the unit for a long time.

When you use the unit in a sandy or dusty place such as a beach, do not let sand or fine dust get into the body and terminals of the unit.

Also, keep the unit away from sea water.

- Sand or dust may damage the unit. (Care should be taken when inserting and removing a card.)

- If sea water splashes onto the unit, wipe off the water with a well wrung cloth. Then wipe the unit again with a dry cloth.

When carrying the unit, do not drop or bump it.

- A strong impact can break the unit's casing, causing it to malfunction.
- When carrying this unit, please hold the handle, hand strap or shoulder strap firmly and treat it with care.

Cleaning

- Before cleaning, detach the battery or pull the AC cable from the AC outlet, and then wipe the unit with a soft, dry cloth.
- If the unit is very dirty, dip a cloth in water and squeeze firmly, and then wipe the unit with the damp cloth. Next, dry the unit with a dry cloth.
- Use of benzine, paint thinner, alcohol, or dishwashing liquid may alter the camera body or peel the surface finish. Do not use these solvents.
- When using a chemical dust cloth, follow the instructions that came with the cloth.

When you are not going to use the unit for an extended time

- When storing the unit, it is recommended that you place a desiccant (silica gel) in with it.

Do not lift up this unit by the handle with the tripod still attached

- When the tripod is attached, its weight will also affect the unit's handle, possibly causing the handle to break and hurting the user.
- To carry the unit while the tripod is attached, take hold of the tripod.

Do not swing the unit around, shake it by, or allow it hang from the handle

- Do not jar, swing, or shake the unit by its handle. Any strong jolt to the handle may damage the unit or result in personal injury.

Do not allow the cord to drag on the ground or pull a connected cord along the passage

- The cord will be damaged, causing fire or electrical shock, when the cord gets caught by the feet, excite will also cause personal injury.

When this unit is turned on, do not use it in direct contact with the skin for a long period of time.

- When using this unit for a long period of time, use a support such as a tripod. Low temperature burns may result if any high temperature part of this unit or hot air from the ventilation openings on the front side of the hand strap of this unit is in direct contact with the skin for a long period of time.

About the battery

The battery used in this unit is a rechargeable lithium-ion battery. It is susceptible to humidity and temperature and the effect increases the more the temperature rises or falls. In cold areas, the full charge indication may not appear or the low battery indication may appear about 5 minutes after starting use. At high temperatures, the protection function may be triggered, making it impossible to use the unit.

Be sure to detach the battery after use.

- If the battery is left attached, a minute amount of current continues to flow even if the unit is off. Keeping the unit in this state may result in over discharge of the battery. This may result in you not being able to use the battery even after it is charged.
- The battery should be stored in the vinyl bag so metal does not come into contact with the terminals.
- The battery should be stored in a cool place free from humidity, with as constant temperature as possible. (Recommended temperature: 15 °C to 25 °C, Recommended humidity: 40%RH to 60%RH)
- Extremely high temperatures or low temperatures will shorten the life of the battery.
- If the battery is kept in high-temperature, high-humidity, or oily-smoky places, the terminals may rust and cause malfunctions.
- To store the battery for a long period of time, we recommend you charge it once every year and store it again after you have completely used up the charged capacity.
- Dust and other matter attached to the battery terminals should be removed.

Prepare spare batteries when going out for recording.

- Prepare batteries enough to last for 3 to 4 times the period you are planning to record for. Cold places such as a ski resort can shorten recording time.

If you drop the battery accidentally, check to see if the terminals are damaged.

- When this unit or battery charger is attached with the terminal part in a deformed state, this unit or battery charger may be damaged.

Do not throw old battery into fire.

- Heating a battery or throwing it into a fire may result in an explosion.

If the operating time is very short even after the battery has been recharged, the battery has worn out. Please purchase a new battery.

About the AC adaptor/battery charger

- If the temperature of the battery is extremely high or extremely low, charging may take time or the battery may not be charged.
- If the CHARGE indicators keeps flashing in orange, make sure that the terminals of the battery or the battery charger are not exposed to dirt, foreign objects or dust, then reconnect them properly.
Disconnect the AC cable from the AC outlet when you remove dirt, foreign objects or dust on the terminals of the battery or the battery charger.
- If the battery's temperature is excessively high or excessively low, the CHARGE indicators will blink orange. Charging will start automatically when the battery reaches an acceptable temperature for charging.
- If the CHARGE indicators blinks orange when the battery's temperature is normal, the battery or the battery charger may be malfunctioning. In such cases, contact your dealer.
- If you use the AC adaptor or battery charger near a radio, radio reception may be disturbed. Keep the AC adaptor or battery charger 1 m or more away from the radio.

- When using the AC adaptor or battery charger, it may generate whirring sounds. However, this is normal.
- After use, be sure to disconnect the AC cable from the AC outlet. (If you leave this unit connected, the AC adaptor will consume approximately 0.1 W.)
- Always keep the electrodes of the AC adaptor, battery charger and battery clean.
- **Install the device near an AC outlet so that the power disconnection device (AC mains plug) can be accessed easily by hand.**

About the SD card

When disposing of or giving away the SD card, note that:

- Formatting and deletion of this unit or computer only changes the file management information and does not completely delete the data in the SD card.
- It is recommended that the main SD card is either physically destroyed or the SD card is physically formatted using this unit when disposing of or giving away the SD card.
- To physically format, connect this unit to the AC adaptor, select [OTHER FUNCTION] → [FORMAT MEDIA] → [SD CARD 1] or [SD CARD 2] from the menu, and touch [YES]. Press and hold recording start/stop button in the following screen for three seconds. Screen to delete the SD card data is displayed, so select [YES] and follow the instruction on the screen.

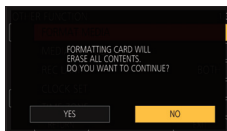

- The customer is responsible for the management of the data in the SD card.

LCD monitor/viewfinder

- When the LCD screen is dirty or condensation has occurred, please wipe it using a soft cloth such as a lens cloth.
- Do not touch the LCD monitor with your fingernails, or rub or press with strong force.
- It may become hard to see or hard to recognize the touch when the LCD protection sheet is affixed.
- When the unit has become very cold, for example due to storage in a cold area, its LCD monitor will be slightly darker than usual immediately after the unit is turned on. The normal brightness will be restored when the unit's internal temperature rises.

Extremely high precision technology is employed to produce the LCD Monitor screen. The result is more than 99.99% effective dots with a mere 0.01% of the dots inactive or always lit. However, this is not a malfunction and does not affect the recorded picture.

Extremely high precision technology is employed to produce the viewfinder screen. The result is more than 99.99% effective dots with a mere 0.01% of the dots inactive or always lit. However, this is not a malfunction and does not affect the recorded picture.

About personal information

When this unit is connected to iPad, the SSID, Password, and other personal information will be included in this unit.

Setting a [NETWORK SETUP PASSWORD] is recommended to protect personal information.

Disclaimer

- Information including personal information may be altered or vanish due to erroneous operation, effect of static electricity, accident, malfunction, repair, or other handlings. Please note in advance that Panasonic is not liable in any way for any direct or indirect damage from the alteration or vanishing of information or personal information.

When requesting a repair, transferring to another party, or disposing.

- After making a copy of personal information, always delete information such as personal information and wireless LAN connection settings that you have saved within this unit with [NETWORK INITIAL SETTING]/[INITIAL SET].
- Remove the Memory Card from this unit when requesting a repair.
- Settings may return to factory default when this unit is repaired.
- Please contact the dealer where you purchased this unit or Panasonic if above operations are not possible due to malfunction.

When transferring to another party, or disposing of the Memory Card, please refer to "When disposing of or giving away the SD card, note that:". (→ 6)

■ About the recording method for recording motion pictures

This unit can record motion pictures using three different recording methods, including MOV, MP4 and AVCHD*.

* AVCHD Progressive (1080/60p, 1080/50p) supported.

MOV and MP4:

These recording methods are suitable for editing images. Audio is recorded in linear PCM.

- Those methods are not compatible with motion pictures recorded in AVCHD format.

- Those methods can record motion pictures in formats that support 4K. 4K motion pictures offer a resolution four times higher than that of full high-definition motion pictures.

AVCHD:

This recording method is suitable for playback on a high-definition compatible external monitor. Audio is recorded in Dolby® Digital.

■ Regarding system frequencies

You can change the system frequency (59.94 Hz/50.00 Hz) for this unit by using the menu. ([SYSTEM FREQ]: → 29)

- You cannot store AVCHD scenes recorded with different system frequencies on the same SD card. If you have switched the system frequency, use another SD card.

■ Indemnity about recorded content

Panasonic does not accept any responsibility for damages directly or indirectly due to any type of problems that result in loss of recording or edited content, and does not guarantee any content if recording or editing does not work properly.

Likewise, the above also applies in a case where any type of repair is made to the unit.

■ About Condensation (When the lens, the viewfinder or LCD Monitor is fogged up)

Condensation occurs when there is a change in temperature or humidity, such as when the unit is taken from outside or a cold room to a warm room. Please be careful, as it may cause the lens, the viewfinder or LCD monitor to become soiled, moldy, or damaged.

When taking the unit to a place which has a different temperature, if the unit is accustomed to the room temperature of the destination for about one hour, condensation can be prevented. (When the difference in temperature is severe, place the unit in a plastic bag or the like, remove air from the bag, and seal the bag.) When condensation has occurred, remove the battery and/or the AC adapter and leave the unit like that for about one hour. When the unit becomes accustomed to the surrounding temperature, fogginess will disappear naturally.

■ About security

Be careful about the possibility of theft or loss of the unit, and be careful not to leave the unit unattended. Please note that Panasonic does not accept any responsibility for the compromise, manipulation, and loss of information caused by these events.

■ Caution regarding laser beams



The lens may suffer damage if struck by a laser beam. Make sure that laser beams do not strike the lens when shooting in an environment where laser devices are used.

■ Cards that you can use with this unit

SDHC Memory Card and SDXC Memory Card

- 4 GB or more Memory Cards that do not have the SDHC logo or 48 GB or more Memory Cards that do not have the SDXC logo are not based on SD Memory Card Specifications.
- Refer to page 23 for more details on SD cards.

■ For the purposes of these operating instructions

- The battery pack is referred to as the "Battery".
- SDHC Memory Card and SDXC Memory Card are referred to as the "SD card".
- Function that can be used for Recording Mode:  Function that can be used for Playback Mode: 
- Scene(s) recorded with [REC MODE] set to [MOV] or [MP4]: "MOV/MP4 scene(s)".
- Scene(s) recorded with [REC MODE] set to [AVCHD]: "AVCHD scene(s)".
- Pages for reference are indicated by an arrow, for example: → 00

Contents

| | |
|-----------------------------------|----|
| Information for Your Safety | 2 |
| Accessories | 10 |
| Optional accessories | 10 |

Preparation

| | |
|--|----|
| What you can do with this unit | 11 |
| Recording to the SD card | 11 |
| Linking to external devices | 11 |
| Remote operations with an iPad | 12 |
| Names and Functions of Main Parts | 13 |
| Power supply | 19 |
| Charging the battery | 19 |
| Inserting/removing the battery | 21 |
| Charging and recording time | 21 |
| Connecting to the AC outlet | 22 |
| Preparation of SD cards | 23 |
| Cards that you can use with this unit .. | 23 |
| Inserting/removing an SD card | 24 |
| Turning the unit on/off | 25 |
| Selecting a mode | 25 |
| Using the LCD monitor/Viewfinder | 26 |
| Using the LCD monitor | 26 |
| How to use the touch screen | 27 |
| Viewfinder adjustment | 27 |
| Setting date and time | 28 |
| Language Selection | 28 |

Recording

| | |
|--|----|
| Selecting a media to record | 29 |
| Formatting media | 29 |
| System frequency Selection | 29 |
| Recording motion picture | 30 |
| Switching between Auto and Manual Mode ... | 30 |
| Using the zoom | 31 |
| Manual Recording | 32 |
| Focus | 32 |
| White Balance | 32 |
| Iris/Gain adjustment | 33 |
| Manual shutter speed | 33 |
| USER button | 34 |
| Setting the USER button | 34 |
| Using the USER button | 34 |
| Functions of the USER button | 35 |

Playback

| | |
|---|----|
| Motion picture/Still picture playback ... | 37 |
|---|----|

Menu

| | |
|-----------------------------|----|
| Using the menu screen | 39 |
| Menu structure | 40 |

Others

| | |
|-----------------------|----|
| Troubleshooting | 42 |
| About copyright | 44 |
| Specification | 45 |

For United Kingdom and Ireland customers

■ Sales and Support Information

Customer Communications Centre

- For customers within the UK: 0344 844 3899
- For customers within Ireland: 01 289 8333
- Monday–Friday 9:00 am – 5:00 pm
(Excluding public holidays).
- For further support on your product, please visit our website:
www.panasonic.co.uk

Direct Sales at Panasonic UK

- Order accessory and consumable items for your product with ease and confidence by phoning our Customer Communications Centre Monday–Friday 9:00 am – 5:00 pm (Excluding public holidays).
- Or go on line through our Internet Accessory ordering application at www.pas-europe.com.
- Most major credit and debit cards accepted.
- All enquiries transactions and distribution facilities are provided directly by Panasonic UK.
- It couldn't be simpler!
- Also available through our Internet is direct shopping for a wide range of finished products. Take a browse on our website for further details.

Accessories

Check the accessories before using this unit.

Keep the accessories out of reach of children to prevent swallowing.

Product numbers correct as of November 2016. These may be subject to change.

Battery pack

AG-VBR59



Battery charger

AG-BRD50^{*1}



AC adaptor

SAE0011



AC cable

(HC-X1E)

(A) K2CT2YY00095

(B) K2CQ2YY00117

(HC-X1GC)

(A) K2CT2YY00095

• In Saudi Arabia, always use

(A).

(B) K2CQ2YY00117

(C) K2CJ2YY00052



Microphone holder

mounting screws (→ 18)

VYC1144

12 mm length

(2 screws)



SYA0021

Microphone holder (→ 18)

VYC1146



INPUT terminal cap

(2 caps)^{*2}

VJF1468



Eye cup (→ 17)

SYA0048



Lens hood^{*3}

SYK1585



Optional accessories

Some optional accessories may not be available in some countries.

Unidirectional microphone

(AG-MC200G)

Battery pack (VW-VBD58/AG-VBR59/AG-VBR89/AG-VBR118)

Battery charger (AG-B23/AG-BRD50^{*1})

LED video light (VW-LED1)

Product numbers correct as of November 2016. These may be subject to change.

^{*1} The AG-BRD50 is available for purchase as an optional accessory package containing a battery charger, AC adaptor, and AC cable.

Individual battery chargers are sold under the model number SAB0002. Contact your dealer to purchase them.

^{*2} The INPUT terminal caps are supplied with the microphone holder.

^{*3} The lens hood is attached to this unit at the time of purchase.

What you can do with this unit

Recording to the SD card

It is possible to record motion pictures and still pictures to the SD card using a variety of recording functions.

- This unit supports relay/simultaneous/background/dual codec recording using double card slots.

Linking to external devices

USB Device Mode

Transfer data (files) to perform nonlinear editing on another device (PC, etc.).

- This unit supports USB 3.0.

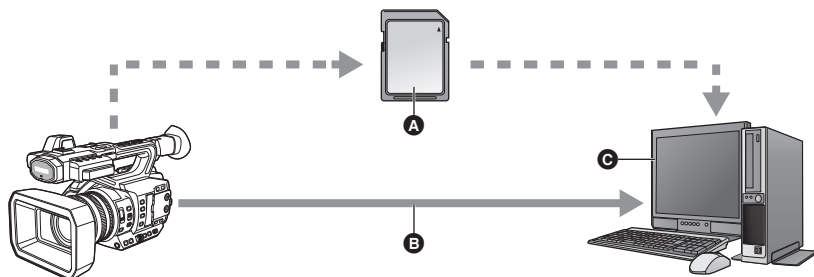

- A** SD card*¹ **C** PC
B USB 3.0 (Device mode)*²

*1 SD cards are optional and not supplied with this unit.

*2 A USB 3.0 cable is not supplied with this unit. Use a commercially-available double-shielded USB 3.0 cable with a ferrite core.

If possible, we recommend using a cable with a length of 1.5 m or less.

USB Host Mode

If you connect an external media device, such as USB HDD or USB flash memory (commercially-available) to this unit, you can copy motion pictures and still pictures recorded on this unit to the external media device. It can also play back the scenes and still pictures copied to the external media device.

- This unit supports USB 3.0.

Refer to the following support site for information about an external media device.

http://panasonic.jp/support/global/cs/e_cam

(This Site is English only)

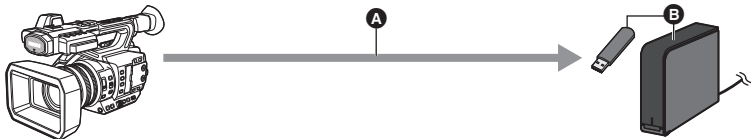

- A** USB 3.0 (Host mode)
- B** External media device (commercially-available)

Connecting to an external monitor

Connect an external monitor to output images.

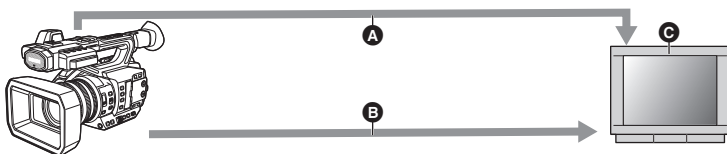

- A** AV cable*¹
- B** HDMI cable*²
- C** External monitor

*1 Use a commercially-available AV cable.

*2 Use a commercially-available High Speed HDMI cable.

If possible, we recommend using a cable with a length of 3 m or less.

**When connecting with an HDMI cable using an HDMI-to-DVI converter, etc., be sure to connect the HDMI cable to the connector of this unit last.
Connecting the HDMI cable to the connector of this unit first may result in malfunction.**

Remote operations with an iPad

Attaching a wireless module that support this unit (AJ-WM50, AJ-WM30: optional*) to the USB HOST terminal of this unit allows you to connect to a wireless LAN network. You can perform the following operations by connecting this unit and an iPad on which the AG ROP application is installed:

- Checking the camera status
- Checking the thumbnail images of recorded scenes
- Playing back scenes recorded as sub recordings with [DUAL CODEC REC] set to [FHD 8Mbps]
- Controlling the camera remotely (recording control and Time Code/User Information operations)

* It may not be available in some countries.

Names and Functions of Main Parts

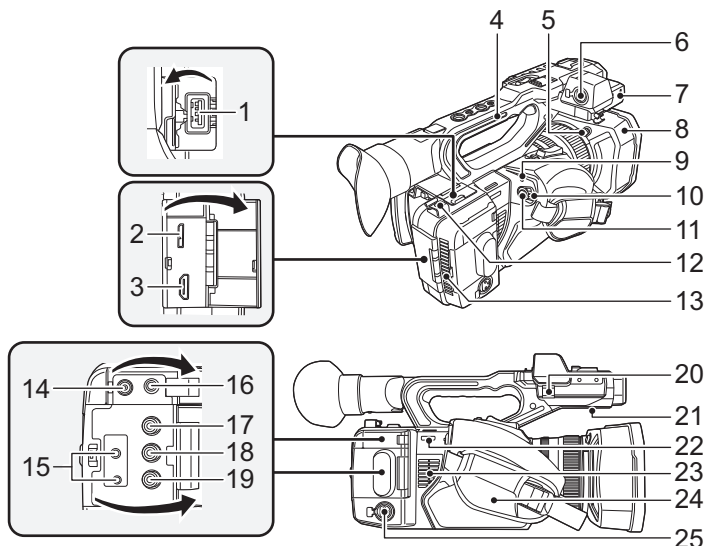

- 1 **USB HOST terminal**
- 2 **USB DEVICE terminal**
- 3 **HDMI OUT connector [HDMI]**
- 4 **Handle**
- 5 **Lens hood release button**
- 6 **Audio input terminal 1 (XLR 3 pin) [AUDIO INPUT1] (→ 18)**
- 7 **Microphone holder attachment part (→ 18)**
- 8 **Lens hood**
- 9 **Status indicator (→ 25)**
- 10 **Power switch (→ 25)**
- 11 **Recording start/stop button (→ 30)**
- 12 **Cable holder**
 - Secures an HDMI cable.
- 13 **Inlet (cooling fan)**
- 14 **DC input terminal [DC IN] (→ 22)**
 - Do not use any other AC adaptors except the supplied one.

- 15 **Camera remote terminal [CAM REMOTE]**
 - FOCUS IRIS terminal (3.5 mm diameter mini jack)
 - ZOOM S/S terminal (2.5 mm diameter super mini jack)
- 16 **Headphone terminal []**
- 17 **VIDEO OUT terminal**
- 18 **AUDIO OUT CH1 terminal**
- 19 **AUDIO OUT CH2 terminal**
- 20 **Microphone cable clamper (→ 18)**
- 21 **Speaker**
- 22 **Shoulder strap fixture**
- 23 **Inlet (cooling fan)**
- 24 **Hand strap (→ 17)**
- 25 **Audio input terminal 2 (XLR 3 pin) [AUDIO INPUT2] (→ 18)**

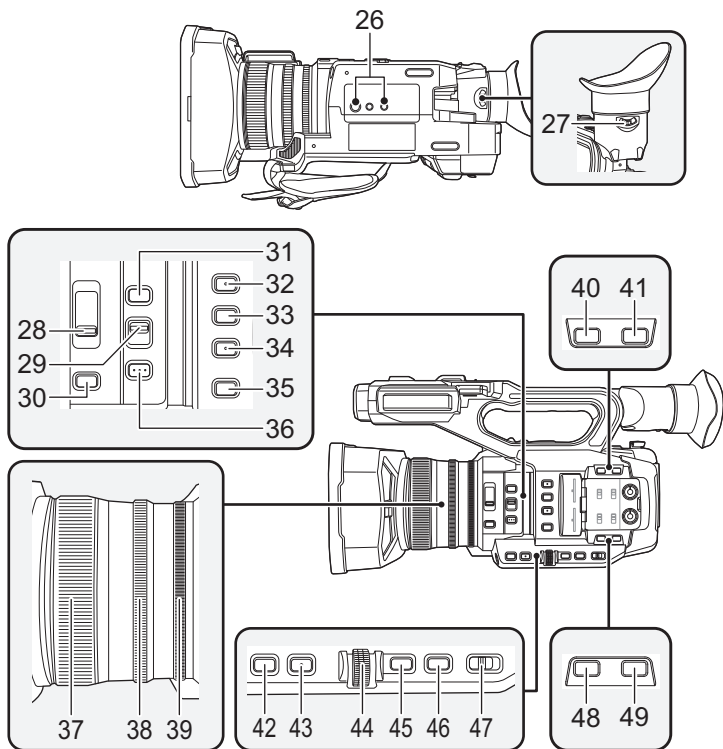

26 Tripod receptacle

- There are tripod mounting holes that are compatible with 1/4-20UNC and 3/8-16UNC screws. Use the size that matches the diameter of the tripod's fixing screw.
- Attaching a tripod with a screw length of 5.5 mm or more may damage the unit.

27 Eyepiece corrector lever (→ 27)

28 ND filter switch [ND FILTER]

29 Focus Auto/Manual/ ∞ switch

[FOCUS A/M/ ∞] (→ 32)

30 Iris button [IRIS] (→ 33)

31 FOCUS ASSIST button

32 User 1 button [USER1] (→ 34)

33 User 2 button [USER2] (→ 34)

34 User 3 button [USER3] (→ 34)

35 Display/Mode check button [DISP/MODE CHK]

36 PUSH AUTO button

37 Focus ring (→ 32)

38 Zoom ring (→ 31)

39 Iris ring (→ 33)

40 User 6 button [O.I.S.] (→ 34)

41 User 7 button [LCD/EVF] (→ 34)

42 Gain button [GAIN] (→ 33)

43 White Balance button [WHITE BAL] (→ 32)

44 Jog dial [SEL/PUSH SET] (→ 32)

45 Menu button [MENU] (→ 39)

46 Shutter speed button [SHUTTER] (→ 33)

47 Auto/Manual switch [AUTO/MANU] (→ 30)

48 User 4 button [WFM] (→ 34)

49 User 5 button [ZEBRA] (→ 34)

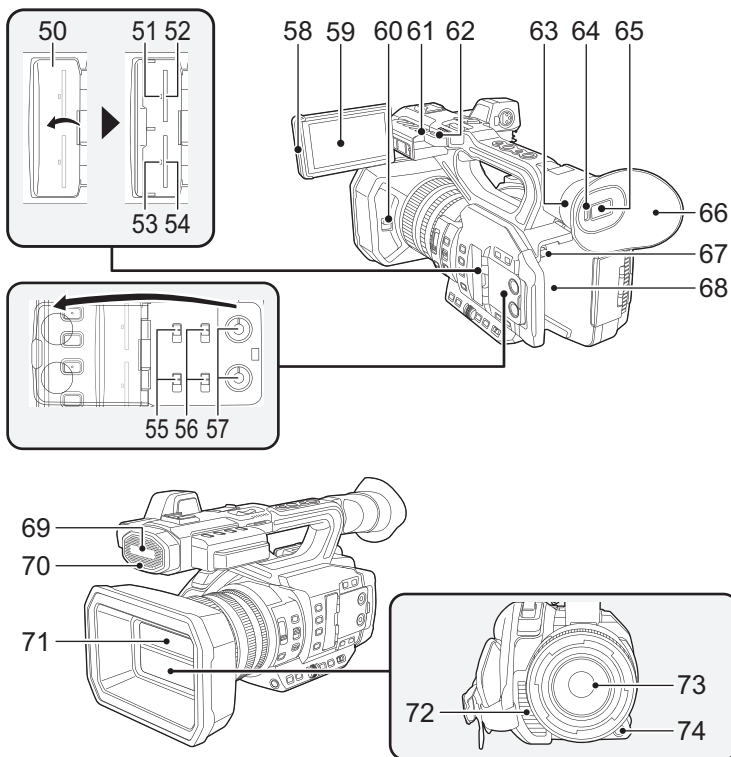

- | | |
|--|---|
| 50 SD Card slot cover (→ 24) | 63 Eye cup mount (→ 17) |
| 51 Access lamp (card 1) (→ 24) | 64 Eye sensor |
| 52 Card slot 1 (→ 24) | 65 Viewfinder (→ 27) |
| 53 Access lamp (card 2) (→ 24) | 66 Eye cup (→ 17) |
| 54 Card slot 2 (→ 24) | 67 Battery release button [PUSH] (→ 21) |
| 55 INPUT1 / INPUT2 switches | 68 Battery holder (→ 21) |
| 56 CH1 SELECT/CH2 SELECT switches | 69 Built-in microphone |
| 57 AUDIO LEVEL CH1/AUDIO LEVEL CH2 knobs | 70 Recording lamp (Front) |
| 58 LCD monitor extract part (→ 26) | 71 Lens cover (→ 17) |
| 59 LCD monitor (Touch screen) (→ 27) | 72 Exhaust opening (cooling fan) |
| 60 Lens cover open/close lever (→ 17) | 73 Lens (LEICA DICOMAR) |
| 61 Recording lamp (Rear) | 74 User 9 button [AWB] (→ 32, 34) |
| 62 Shoulder strap fixture | |

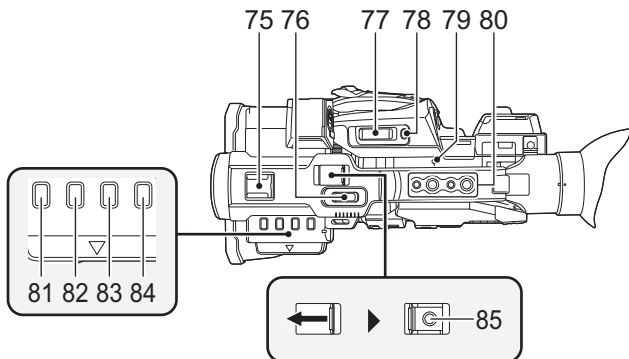

75 Accessory shoe

76 Sub zoom lever (→ 31)

- This lever functions in the same manner as the zoom lever.
- The zoom speed is controlled with this lever in a way different from the way it is controlled with the zoom lever. (→ 31)

77 Zoom lever [T/W] (In Recording Mode) (→ 31)

Volume lever [+VOL-]/Thumbnail display switch [Q / 

78 User 8 button [REC CHECK] (→ 34)

79 Focal plane index [ϕ]

- Indicates the focal plane of the MOS sensor.

80 Handle mounting hole

(Size of the mounting hole)

- 1/4-20UNC×2
- 3/8-16UNC×2

81 Thumbnail button [THUMBNAIL] (→ 25)

82 Counter button [COUNTER]

83 Counter reset button [RESET]

84 Color Bar Screen button [BARS]

85 Sub recording start/stop button

- This button functions in the same manner as the recording start/stop button.

■ Opening/closing the lens cover

You can open/close the lens cover by sliding the lens cover open/close lever.

- When this unit is not in use, close the lens cover to protect the lens.

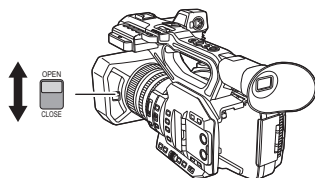

-
- Do not press the lens cover hard. This may damage the lens or the lens cover.
 - Depending on the various filters or the MC protector attached to the front side of this unit's lens, you may not be able to open/close the lens cover or attach the lens hood.

■ Adjust the length of the hand strap so that it fits your hand.

Adjust the hand strap according to the size of your hand.

- If you find it difficult to fasten the buckle **B**, move the pad **A** forward, and fasten the buckle **B** again.

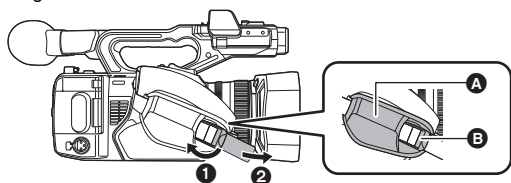

- 1 Open the buckle.
- 2 Pull the end of the belt.

■ Attaching the eye cup

- 1 Align the mounting mark on the eye cup mount with the corresponding mark on the eyecup.
- 2 Attach the eye cup so that the notch on the eye cup mount is aligned with the protrusion inside the eye cup.

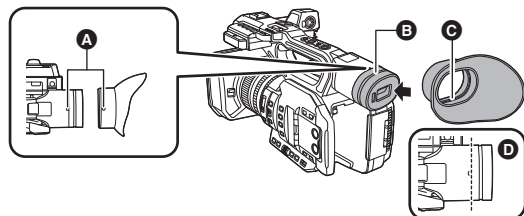

- A Mounting marks
- B Notch
- C Protrusion

- Push the eye cup in until it reaches the mounting mark. **(D)**

■ Attaching the front microphone

- The microphone holder is set up so that a 21 mm external microphone (AG-MC200G: optional) can be attached. Check in advance whether the microphone you wish to use can be attached.

1 Attach the microphone holder to the microphone holder attachment part.

- Attach by using a commercially available screw driver.
- When attaching the microphone holder, be sure to tighten the screws firmly even though you might hear a squeaking sound.

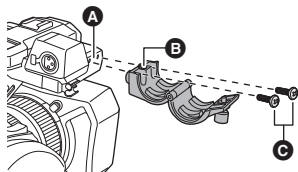

- A** Microphone holder attachment part
- B** Microphone holder
- C** Microphone holder mounting screws

2 Attach an external microphone (optional) to the microphone holder, and tighten the microphone holder screw.

3 Connect the external microphone to the AUDIO INPUT1 terminal (XLR 3 pin).

- When wiring the microphone cable, use the cable clammer of this unit.
- Keep the microphone holder screw and INPUT terminal cap out of reach of children to prevent swallowing.

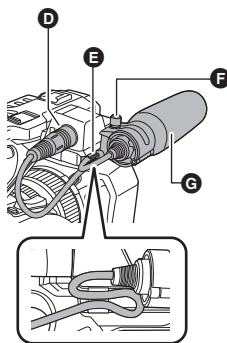

- D** AUDIO INPUT1 terminal (XLR 3 pin)
- E** Microphone cable clammer
- F** Microphone holder screw
- G** External microphone (optional)

■ Attaching the INPUT terminal cap

Attach the INPUT terminal cap while the AUDIO INPUT1, 2 terminals (XLR 3 pin) are not used.

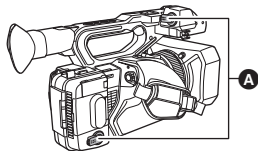

- A** INPUT terminal cap

Power supply

■ About batteries that you can use with this unit (as of November 2016)

The batteries that can be used with this unit are VW-VBD58/AG-VBR59/AG-VBR89/AG-VBR118.

- The AG-VBR59/AG-VBR89/AG-VBR118 supports quick charging.

It has been found that counterfeit battery packs which look very similar to the genuine product are made available to purchase in some markets. Some of these battery packs are not adequately protected with internal protection to meet the requirements of appropriate safety standards. There is a possibility that these battery packs may lead to fire or explosion. Please be advised that we are not liable for any accident or failure occurring as a result of use of a counterfeit battery pack. To ensure that safe products are used we would recommend that a genuine Panasonic battery pack is used.

Charging the battery

When this unit is purchased, the battery is not charged. Charge the battery fully before using this unit for the first time.

Important:

- Do not use the AC cable with any other equipment as it is designed only for this unit. Also, do not use the AC cable from other equipment with this unit.
- It is recommended to charge the battery in a temperature between 10 °C and 30 °C. (The battery temperature should also be the same.)

■ About the Battery Charger

This unit can charge two battery packs simultaneously and supports quick charging batteries.

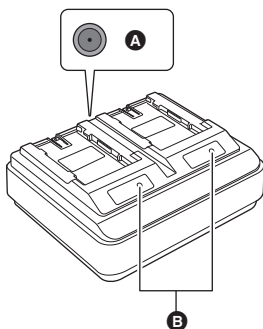

- A** DC IN 12 V connector
- B** CHARGE indicators [CHARGE 1/CHARGE 2]

CHARGE indicators [CHARGE 1/CHARGE 2]

Indicate the charge status as follows.

| Indicator | Charge status |
|-----------------|--|
| Lit green | Quick charging is in progress. (Battery charging time: → 21) |
| Lit orange | Normal charging is in progress. |
| Blinking orange | Charging has stopped due to an error. (→ 6) |
| Off | Charging is complete, or a battery pack is not inserted. |

DC IN 12 V connector []

Connects to the DC plug of the AC adaptor.

■ Charging the battery

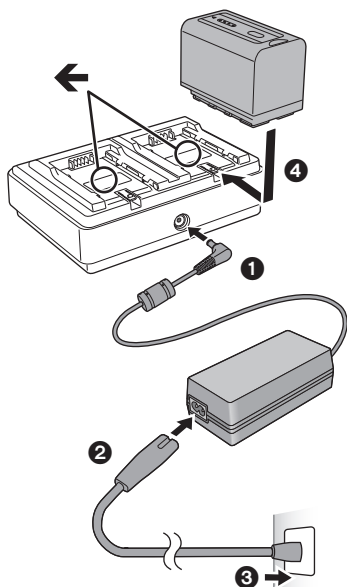

1 Connect the DC plug of the AC adaptor to the DC IN 12 V connector of battery charger.

2 Connect the AC mains lead to the AC adaptor.

- Perform step **2** first, and then step **3**. Insert the AC mains lead all the way in until it stops.

3 Insert the battery into the battery charger.

- Slide the battery horizontally into the battery charger along the “←” mark.
- The corresponding CHARGE indicator lights and charging starts.
- The CHARGE indicator turns off when charging is complete. Slide the battery to remove it.

-
- We recommend using Panasonic batteries (→ 10, 19, 21).
 - If you use other batteries, we cannot guarantee the quality of this product.
 - Do not heat or expose to flame.
 - Do not leave the battery(ies) in a car exposed to direct sunlight for a long period of time with doors and windows closed.
 - After the battery is inserted, it may take some time for it to be detected and the CHARGE indicator to light. If the CHARGE indicator does not light after 10 seconds, insert the battery again.
 - If two batteries that support quick charging are inserted, priority will be given to the battery inserted in the CHARGE 1 slot, and the battery inserted in the CHARGE 2 slot will be charged in normal-charge mode. When charging on the CHARGE 1 slot progresses to a certain point, charging on the CHARGE 2 slot will automatically switch to quick-charge mode. In addition, the charge indicator (LED lamps) on the battery inserted in the CHARGE 2 slot may turn off depending on the charge status of the battery.
 - The battery charger determines the state of the battery first to perform optimal charging. It will, as a result, take about 20 seconds for charging to start after the CHARGE indicator on the battery charger lights. When charging starts, the charge indicator (LED lamps) on a battery that supports quick charging will flash. If you remove and reinsert a battery or swap batteries while charging is in progress on both the CHARGE 1 and CHARGE 2 slots, charging for both batteries will stop temporarily, and the battery charger will determine the state of the batteries again before restarting. Therefore, it will take about 20 seconds to restart charging.
 - Insert the battery that you want charged first in the CHARGE 1 slot.

Inserting/removing the battery

Install the battery by inserting it in the direction shown in the figure.

- Insert the battery until it clicks and locks.

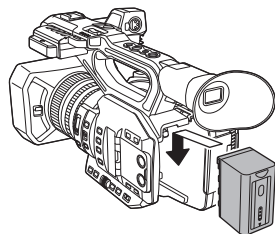

Removing the battery

Make sure that the power switch is set to OFF and the status indicator is turned off, and then remove by holding onto it taking care not to drop. (→ 25)

While pressing the battery release button, remove the battery.

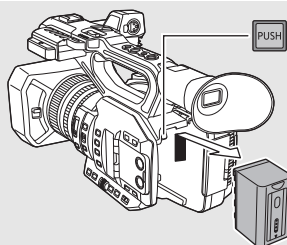

Charging and recording time

Charging/Recording time

| Battery model number | Voltage/Capacity (minimum) | Charging time | System Frequency setting (→ 29) | Continuously recordable time |
|---------------------------------------|----------------------------|---------------|---------------------------------|------------------------------|
| Supplied battery/ AG-VBR59 (optional) | 7.28 V/5900 mAh | 3 h 20 min | 59.94 Hz | 3 h 25 min |
| | | | 50.00 Hz | 3 h 35 min |

- The above charging times apply when the supplied battery charger is used.
- The times given apply when the ambient operating temperature is 25 °C and the relative operating humidity is 60%. Charging time may be longer at other temperatures and humidity levels.
- The continuous recordable time given applies under the conditions below. The time becomes shorter under other conditions.
 - The LCD monitor is open
 - A cable is not inserted to the external output terminal
- "h" is an abbreviation for hour, "min" for minute and "s" for second.
- These times are approximations.
- **The indicated charging time is for when the battery has been discharged completely. Charging time and recordable time vary depending on the usage conditions such as high/ low temperature.**

- The batteries heat up after use or charging. This is not a malfunction.
- The optional battery charger AG-B23 (DE-A88) can be used to charge the battery but charging will take longer.

Battery capacity indication

- The display changes as the battery capacity reduces. If the battery discharges, then  will flash red.



Connecting to the AC outlet

The unit is in the standby condition when the AC adaptor is connected. The primary circuit is always "live" as long as the AC adaptor is connected to an electrical outlet.

Important:

- Use the supplied AC adaptor. Do not use the AC adaptor of another device.
- Do not use the AC cable with any other equipment as it is designed only for this unit. Also, do not use the AC cable from other equipment with this unit.

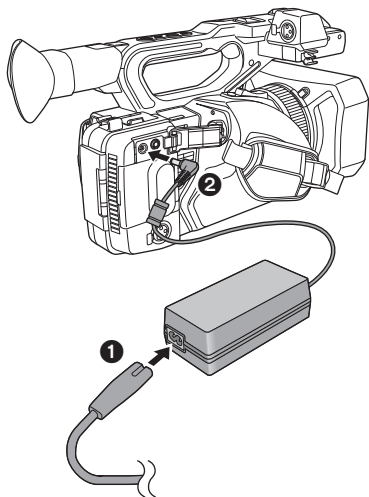

1 Connect the AC cable to the AC adaptor and the AC outlet.

2 Connect the AC adaptor to the DC input terminal [DC IN].

- Make sure to set the power switch to OFF and the status indicator is turned off when disconnecting the AC adaptor. (→ 25)

- Insert the plugs as far as they will go.

- Even when you use the AC adaptor for recording images, keep the battery connected. This allows you to continue the recording even if a power failure occurs or the AC adaptor is unplugged from the AC outlet by accident.

Preparation of SD cards





The unit can record motion pictures or still pictures to an SD card.

- We recommend that you use a Panasonic Memory Card.

Cards that you can use with this unit

■ About the Speed Class ratings for recording motion pictures

- Depending on [REC MODE] and [REC FORMAT], the required card differs.
Use a card that meets the following ratings of the SD Speed Class or UHS Speed Class.
Use of a non-compatible card may cause recording to stop suddenly.
- SD Speed Class and UHS Speed Class are the speed standards regarding continuous writing. To check the class, see the labelled side, etc. of the card.

| Recording modes | Recording function or Recording format | Speed Class ratings | Label examples |
|-----------------|--|--------------------------|---|
| MOV/MP4 | VFR mode, Super Slow Recording, 100 Mbps or more | UHS Speed Class3* |  |
| | 50 Mbps | UHS Speed Class1 or more |  |
| | | Class10 or more |  |
| AVCHD | All | Class4 or more |  |

- Keep the Memory Card out of reach of children to prevent swallowing.
- * If you select [UHD 2160/59.94p 150M] or [UHD 2160/50.00p 150M], you will need an SDXC Memory Card with a capacity of at least 64 GB that supports UHS Speed Class3.

Inserting/removing an SD card

When using an SD card for the first time, it is necessary to format the SD card. (→ 29) When the SD card is formatted, all of the recorded data is deleted. Once the data is deleted, it cannot be restored.

Caution:

Check that the access lamp has gone off.

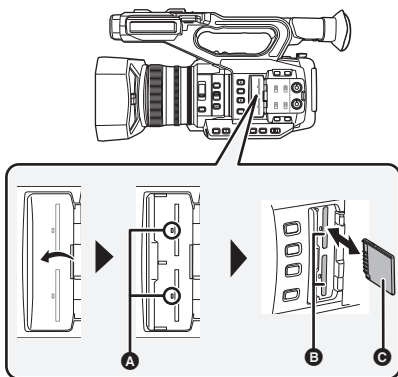

Access lamp **A**

- When this unit is accessing the SD card, the access lamp lights up.

1 Open the SD card slot cover and insert (remove) the SD card into (from) the card slot **B**.

- One SD card can be inserted into each of the card slot 1 and the card slot 2.
- Face the terminal side **C** in the direction shown in the illustration and press it straight in as far as it will go.
- Press the center of the SD card and then pull it straight out.

2 Securely close the SD card slot cover.

- Do not touch the terminals on the back of the SD card.
- Do not apply strong shocks, bend, or drop the SD card.
- Electrical noise, static electricity or the failure of this unit or the SD card may damage or erase the data stored on the SD card.
- When the card access lamp is lit, do not:
 - Remove the SD card
 - Turn the unit off
 - Insert and remove the USB Cable
 - Expose the unit to vibrations or shockPerforming the above while the lamp is on may result in damage to data/SD card or this unit.
- Do not expose the terminals of the SD card to water, dirt or dust.
- Do not place SD cards in the following areas:
 - In direct sunlight
 - In very dusty or humid areas
 - Near a heater
 - Locations susceptible to significant difference in temperature (condensation can occur.)
 - Where static electricity or electromagnetic waves occur
- To protect SD cards, return them to their cases when you are not using them.
- About disposing of or giving away the SD card. (→ 6)

Turning the unit on/off

Set the power switch to **ON** while pressing the lock release button **B** to turn on the unit.

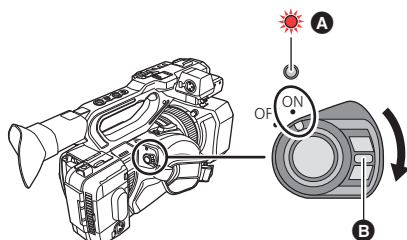

To turn off the unit

Set the power switch to **OFF** while pressing the lock release button. The status indicator goes off.

A The status indicator lights on.

- To turn on the unit again after the [ECONOMY (BATT)] or [ECONOMY (AC)] is activated, set the power switch to OFF once, and then to ON again.

Selecting a mode

Press the **THUMBNAIL** button to change the mode to **Recording Mode** or **Playback Mode**.

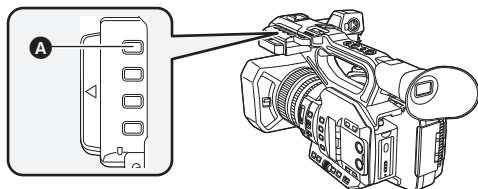

A THUMBNAIL button

| | |
|------------------------------|---|
| Recording Mode (→ 30) | The recording screen is displayed. You can record motion pictures. |
| Playback Mode (→ 37) | The thumbnail screen for playback is displayed. You can play back motion pictures and still pictures. |

- When you turn on this unit, it starts up in Recording Mode.
- If you press the recording start/stop button or sub recording start/stop button in Playback Mode, the mode will be switched to Recording Mode and recording will start.

Using the LCD monitor/Viewfinder

The LCD monitor is turned on when the LCD monitor is extracted. When you move your eye closer to the eye cup of the viewfinder, the LCD monitor is turned off, and the viewfinder is turned on.

Using the LCD monitor

1 Extract the LCD monitor in the direction as indicated in the figure.

- Hold the LCD monitor extract part **A**, and extract the LCD monitor until it clicks into position.

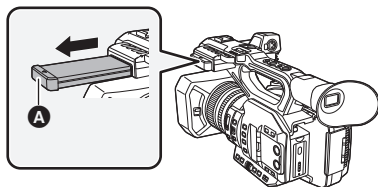

2 Rotate to the position that is easy to view.

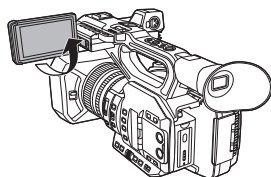

To retract the LCD monitor

Retract as shown in the figure with the LCD facing downward.

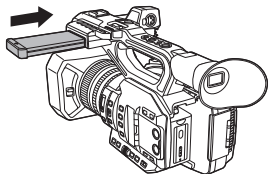

Range of rotation of the LCD monitor

- It can rotate up to 270° towards the lens.

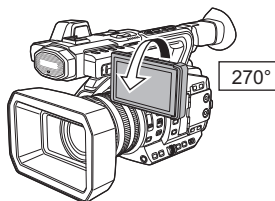

How to use the touch screen

You can operate by directly touching the LCD monitor (touch screen) with your finger.

■ Touch

Touch and release the touch screen to select icon or picture.

- Touch the center of the icon.
- Touching the touch screen will not operate while you are touching another part of the touch screen.

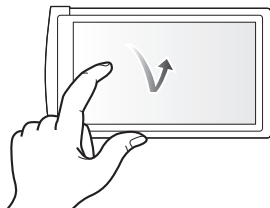

■ Slide while touching

Move your finger while pressing on the touch screen.

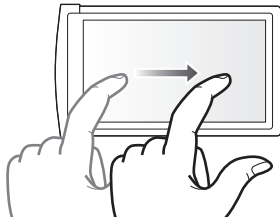

■ About the operation icons



Touch when changing a page or performing settings.

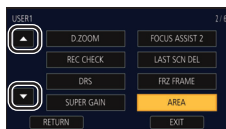

- Do not touch the LCD monitor with hard pointed tips, such as ball point pens.

Viewfinder adjustment

Adjusting the field of view

This setting will not affect the images actually recorded.

It adjusts the field of view to show the image on the viewfinder clearly.

1 Adjust the viewfinder to suit your vision so that you can see the display images clearly.

- Be careful not to trap your fingers when moving the viewfinder.
- The viewfinder can be lifted vertically up to approximately 90°.
- Bring your eye close to the viewfinder to turn it on.

2 Adjust the focus by operating the eyepiece corrector lever.

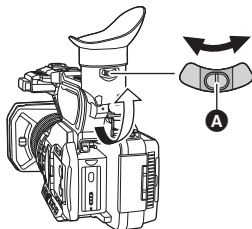

A Eyepiece corrector lever

Setting date and time

When this unit is turned on, the message [SET TIME ZONE AND DATE/TIME] may appear. To make these settings, select [YES], and follow the instructions from Step 2-3 of the time zone setting procedure.

Time zone

Time difference from the Greenwich Mean Time can be set.

1 Select the menu. (→ 39)

 : [OTHER FUNCTION] → [TIME ZONE]

2 Touch / and set the region to record.

3 Touch [EXIT] to complete the setting.

- If the [CLOCK SET] screen appears, perform [CLOCK SET].

- When the time zone setting is changed, the date/time setting of the unit also changes automatically.

Clock setting

1 Select the menu. (→ 39)

 : [OTHER FUNCTION] → [CLOCK SET]

2 Touch the date or time to be set, then set the desired value using / .

- The year can be set between 2000 and 2039.

3 Touch [EXIT] to complete the setting.

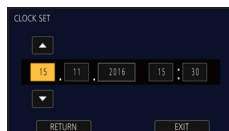

- The date and time function is driven by a built-in lithium battery.
- If the time display becomes [- -], the built-in lithium battery needs to be charged. To recharge the built-in lithium battery, connect the AC adaptor or attach a charged battery to this unit. Leave the unit as it is for approx. 24 hours and the battery will maintain the date and time for approx. 6 months. (The battery is still being recharged even if the unit is off.)
- The way that time is displayed can be changed in the menu settings. [DISP SETUP] → [DATE/TIME] or [DATE FORMAT]

Language Selection

You can select the language on the screen display and the menu screen.

1 Select the menu. (→ 39)

 : [OTHER FUNCTION] → [LANGUAGE]

2 Touch the desired setting language.

Selecting a media to record

You can specify the card slot to which motion pictures are to be recorded.

Select the menu. (→ 39)

: [RECORD SETUP] → [MEDIA SELECT] → [SD CARD 1]/[SD CARD 2]

Formatting media

If you use the SD cards for the first time for recording with this unit, format the cards. Please be aware that if a medium is formatted, then all the data recorded on the medium will be erased and cannot be restored. Back up important data on a PC etc.

- When using two SD cards, format both SD cards.

1 Select the menu. (→ 39)

: [OTHER FUNCTION] → [FORMAT MEDIA]

2 Touch [SD CARD 1] or [SD CARD 2].

- When formatting is complete, touch [EXIT] to exit the message screen.
- Do not turn this unit off or remove the SD card, while formatting. Do not expose the unit to vibrations or shock.

Use this unit to format media.

Do not format an SD card using any other equipment such as a PC. Otherwise it may not be possible to use the card on this unit.

System frequency Selection

Set the system frequency of this unit.

Select the menu. (→ 39)

(In Recording Mode)

: [SYSTEM MODE] → [SYSTEM FREQ] → [59.94Hz] or [50.00Hz]

(In Playback Mode)

: [OTHER FUNCTION] → [SYSTEM FREQ] → [59.94Hz] or [50.00Hz]

- After you have changed the system frequency, this unit will be restarted automatically.
- By default, the system frequency is set to the broadcasting system of the region where this product was purchased.
- This function's default setting is [50.00Hz].



Recording motion picture

- Before turning on this unit, open the lens cover. (→ 17)

1 Change the mode to Recording Mode. (→ 25)

- Extract the LCD monitor.

2 Press the recording start/stop button **B** to start recording.

- A** When you begin recording, REC (red) is displayed.
- Recording will stop when you press the recording start/stop button again.

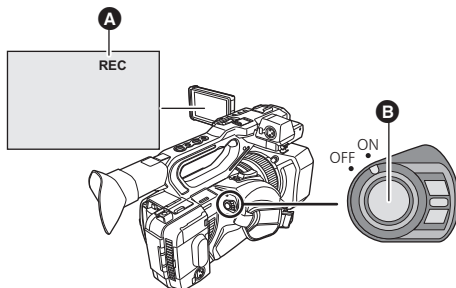

Switching between Auto and Manual Mode

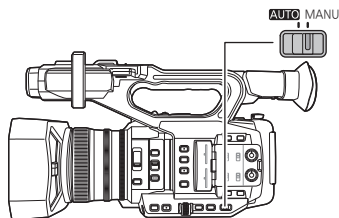

AUTO/MANU switch

Slide the switch to change Auto Mode/Manual Mode.

- **A** is displayed in the Auto Mode.
- In Auto Mode, this unit operates according to the [AUTO SW] menu settings.

- When the following settings are automatically adjusted in Auto Mode, the corresponding Manual Mode settings are canceled:
 - Focus (→ 32)
 - Iris (→ 33)
 - GAIN (→ 33)
 - Shutter speed (→ 33)

■ Controls that are disabled in Auto Mode

Certain controls of this unit may be disabled in Auto Mode. Controls to be disabled vary by the [AUTO SW] menu settings.

| Conditions that disable controls | Controls that are disabled in Auto Mode |
|----------------------------------|--|
| [A.IRIS] is set to [ON]. | Iris Ring, IRIS button |
| [AGC] is set to [ON]. | GAIN button, the USER button to which [SUPER GAIN] is registered |
| [AUTO SHUTTER] is set to [ON]. | SHUTTER button |
| [ATW] is set to [ON]. | WHITE BAL button |
| [AF] is set to [ON]. | Focus ring, FOCUS ASSIST button, FOCUS A/M/ ∞ switch, PUSH AUTO button, the USER button to which [FOCUS ASSIST 1], [FOCUS ASSIST 2], [PUSH AUTO] or [FOCUS TRANS] is registered |

Recording



Using the zoom

The unit can deliver a maximum optical zoom of 20 \times .

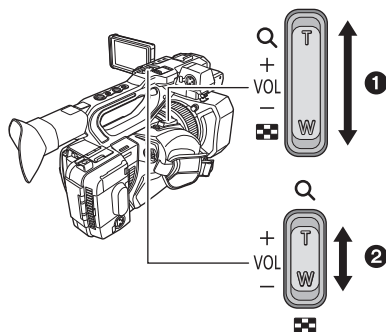

Zoom lever ①/Sub zoom lever ②

T side:

Close-up recording (zoom in)

W side:

Wide-angle recording (zoom out)

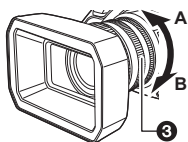

Zoom ring ③

A side:

Wide-angle recording (zoom out)

B side:

Close-up recording (zoom in)

■ About the zoom speed

- The zoom speed will vary depending on how far the zoom lever is pressed or how fast the zoom ring is rotated.
- The zoom operation using the sub zoom lever will be performed at a constant speed. Zoom speed of the sub zoom lever will vary depending on the setting of [SUB ZOOM].



Manual Recording

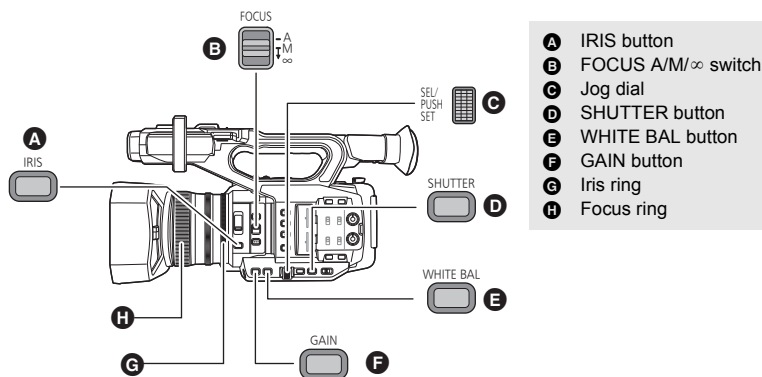

- A** IRIS button
- B** FOCUS A/M/∞ switch
- C** Jog dial
- D** SHUTTER button
- E** WHITE BAL button
- F** GAIN button
- G** Iris ring
- H** Focus ring

Focus

Perform focus adjustments using the focus ring. If auto focusing is difficult due to the conditions, then use Manual Focus.

- Switch to Manual Mode. (→ 30)

1 Set the FOCUS A/M/∞ switch to [M] to enable Manual Focus.

- It will switch to MF from AF.

2 Adjust the focus by rotating the focus ring.

White Balance

Automatic White Balance function may not reproduce natural colors depending on the scenes or lighting conditions. If so, you can adjust the White Balance manually.

- Register [AWB] (Auto White Balance) to a USER button. (→ 34)

It is assigned to the USER9 button by default.

- Switch to Manual Mode. (→ 30)

1 Press the WHITE BAL button to switch to [Ach], [Bch], or [PRST].

- The setting changes each time you press the button.

[Ach] → [Bch] → [PRST]

- If you switch to [PRST], the White Balance mode set in [WB PRESET] will be displayed.

2 (If you have switched to [PRST])

Press the USER button to which [AWB] is registered or touch the applicable USER button icon to change the White Balance mode.

- The mode will change each time you press the USER button to which [AWB] is registered or touch the applicable USER button icon.

[P3200K] → [P5600K] → [VAR]

- It is not possible to change the White Balance mode without registering [AWB] to a USER button.

Iris/Gain adjustment

When recording a scene that is too dark (or bright) or a scene in a similar situation, manually adjust the iris and gain.

■ Iris adjustment

- Switch to Manual Mode. (→ 30)

- A** Iris value
- B** Auto iris icon*

* It is displayed in Auto Iris Mode.

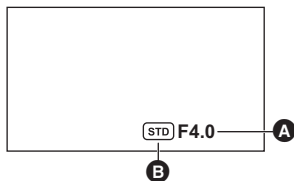

1 Press the IRIS button to switch to Manual Iris Mode.

- [STD] disappears.

2 Adjust the iris by rotating the iris ring.

■ Gain adjustment

- Use the jog dial to change the settings.
- Switch to Manual Mode. (→ 30)



- C** Gain value

• In Auto Gain Mode, "AGC" is displayed; in Manual Gain Mode, the gain value is displayed in dB.

- D** [GAIN]

1 Press the GAIN button to switch to [LOW GAIN], [MID GAIN], or [HIGH GAIN].

- The setting changes each time you press the button.
[LOW GAIN] → [MID GAIN] → [HIGH GAIN]
- It is possible to register gain values to [LOW GAIN], [MID GAIN], and [HIGH GAIN] and switch between these values.
- It is also possible to switch to the desired gain value by pressing the USER button to which [LOW GAIN], [MID GAIN] or [HIGH GAIN] is registered.

2 Push the jog dial.



3 Adjust the gain by rotating the jog dial.



Manual shutter speed

Adjust the shutter speed when recording fast-moving subjects.

- Use the jog dial to change the settings.
- Switch to Manual Mode. (→ 30)

1 Press the SHUTTER button to switch to Manual Shutter Mode.

2 Adjust the shutter speed by rotating the jog dial.



USER button

Each of the USER button can register one function from the 44 available functions.

- There are 9 USER buttons (USER1 to 9) on the main body and 4 USER button icons (USER10 to USER13) displayed on the LCD monitor.

Setting the USER button

1 Select the menu. (→ 39)

: [USER SW] → [USER1] to [USER13]

- It is not possible to register functions to [USER10] to [USER13] in Playback Mode.

2 Touch the item to register.

- For the functions of the USER button that can be registered, refer to page 35.
- Touch [INHIBIT] if not registering.
- Next (Previous) page can be displayed by touching / .

3 Touch [EXIT] to complete the setting.

Using the USER button

To use the function assigned to a USER button or USER button icon, press the applicable USER button (one of the USER buttons 1 to 9), or touch the applicable USER button icon (one of the USER button icons 10 to 13) while operation icons are displayed.

(When you use the USER1 to USER7 button)

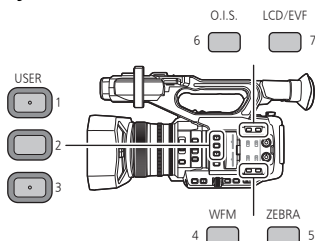

(When you use the USER9 button)

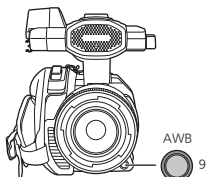

(When you use the USER8 button)

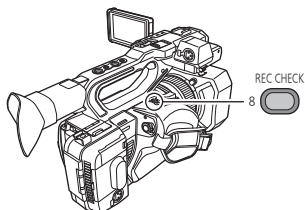

(When you use the USER10 to USER13 button)

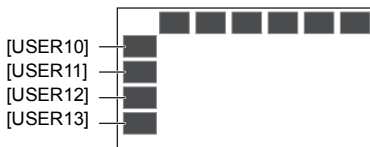

Functions of the USER button

■ List of USER button functions

- Please refer to "Operating Instructions" (PDF format) for more information about the functions of the USER button.

| Item | Icon | Function |
|------------------|------------|--------------------------------|
| [INHIBIT] | [INH] | Invalid |
| [FOCUS ASSIST 1] | [FA1] | Focus Assist 1 |
| [BACKLIGHT] | [B.Light] | Backlight Compensation |
| [SPOTLIGHT] | [S.Light] | Spotlight |
| [BLACK FADE] | [B.FD] | Black Fade |
| [WHITE FADE] | [W.FD] | White Fade |
| [ATW] | [ATW] | Auto Tracking White Balance |
| [ATW LOCK] | [ATW.L] | ATW Lock |
| [D.ZOOM] | [D.ZM] | Digital Zoom |
| [FOCUS ASSIST 2] | [FA2] | Focus Assist 2 |
| [REC CHECK] | [REC.C] | Recording Check |
| [LAST SCN DEL] | [LstDel] | Last Scene Delete |
| [DRS] | [DRS] | DRS |
| [FRZ FRAME] | [FRZ] | Freeze Frame |
| [SUPER GAIN] | [S.Gain] | Super Gain ^{*1} |
| [AREA] | [AREA] | Area Mode |
| [FOCUS TRANS] | [F.Tran] | Focus Transition ^{*2} |
| [PUSH AUTO] | [PushAuto] | Push Auto |
| [EVF/LCD DETAIL] | [DETAIL] | EVF/LCD detail |
| [IR REC] | [IR REC] | Infrared Recording |
| [LEVEL GAUGE] | [Level] | Level Gauge |
| [BACKGROUND] | [Backgr] | Background |
| [FLASH BAND] | [FBC] | Flash band compensation |
| [PRE-REC] | [PRE-REC] | PRE-REC |
| [WFM] | [WFM] | WFM |
| [FAST ZOOM] | [F.ZOOM] | Fast Zoom |
| [EVF ON/OFF] | [EVF SW] | EVF ON/OFF |
| [A.IRIS LEVEL] | [A.IRIS] | Auto Iris Level |
| [ZEBRA] | [ZEBRA] | Zebra |
| [O.I.S.] | [O.I.S.] | Optical Image Stabilizer |

*1 Not available in Auto Mode

*2 Not available for Auto Focus

| Item | Icon | Function |
|------------------|-------------|--------------------------|
| [SCENE FILE] | [SCN FILE] | Scene File |
| [AUTO REC] | [AutoRec] | Auto Rec |
| [AF AREA] | [AF Area] | AF area width adjustment |
| [VFR] | [VFR] | Variable Frame Rate Mode |
| [FOCUS MACRO] | [F.Macro] | Focus Macro |
| [i.ZOOM] | [i.Zoom] | i.Zoom |
| [USB MODE] | [USB] | USB Mode*3 |
| [AWB] | [AWB] | Auto White Balance |
| [SUPER SLOW] | [SuperSlow] | Super Slow Recording |
| [SLOT SEL] | [SlotSel] | Slot Selection |
| [LCD/EVF OUTPUT] | [LCD/EVF] | LCD/EVF Output |
| [LOW GAIN] | [LowGain] | Low gain |
| [MID GAIN] | [MidGain] | Mid gain |
| [HIGH GAIN] | [HighGain] | High gain |
| [MENU] | [MENU] | Menu |

*3 Not available during AG ROP application connection.

- The USER button function can also be set from the following menu item.

- | | |
|-----------------------------|---------------------------|
| – [DRS] | – [O.I.S.] |
| – [EVF/LCD DETAIL] | – SCENE FILE: [LOAD/SAVE] |
| – [INFRARED REC] | – [i.Zoom] |
| – [LEVEL GAUGE] | – [USB MODE] |
| – [FLASH BAND COMPENSATION] | – [AF AREA WIDTH] |
| – [PRE-REC] | – [VFR MODE] |
| – [WFM] | – [FOCUS MACRO] |
| – [FAST ZOOM] | – [SUPER SLOW REC] |
| – [AUTO IRIS LEVEL] | – [LCD/EVF OUTPUT] |
| – [ZEBRA] | |



Motion picture/Still picture playback

- 1 Set this unit to playback mode. (→ 25)
- 2 Touch the play mode select icon **A**.

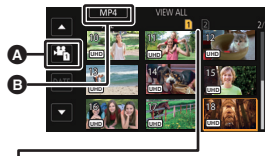

Media display

The selected media is displayed in yellow.

- 3 Select the media **C** you wish to play back.



- 4 (To set this unit to Motion Picture Playback Mode)
Touch the desired recording mode **D** and recording format **E** for playback.



- Recording mode options with recorded scenes are displayed in green.
- The available recording format options differ depending on [SYSTEM FREQ] (→ 29) or the recording mode option you have touched.
- Next (Previous) page can be displayed by touching **▲** / **▼**.
- Touch [ENTER].
- A recording mode icon **B** will be displayed on the thumbnail display. (**MOV** / **MP4** / **AVCHD**)

(If you have touched the recording mode option [MOV] or [MP4])

- After you have touched a recording format option, one of the following icons will be displayed on each thumbnail. The icon to be displayed differs depending on the size of recording format.
 - **4K** : Scenes recorded in 4K (4096×2160)
 - **UHD** : Scenes recorded in UHD (3840×2160)
 - **FHD** : Scenes recorded in FHD (1920×1080)
 - **DUS0** : Scenes recorded as sub recordings with [DUAL CODEC REC] set to [FHD 50Mbps]
 - **DUS8** : Scenes recorded as sub recordings with [DUAL CODEC REC] set to [FHD 8Mbps]
- If you touch the recording format option [ALL], all scenes of the same recording mode in the selected media are displayed.

The thumbnails of scenes with a different system frequency are indicated with **▶** **⊘**. You can play them back by changing the [SYSTEM FREQ] setting. (→ 29)

- (If you have touched the recording mode option [AVCHD])
After you have touched a recording format option, one of the following icons will be displayed on each thumbnail.
 - [PS] : Scenes recorded in [PS 1080/59.94p]/[PS 1080/50.00p]
 - [PH] : Scenes recorded in [PH 1080/59.94i]/[PH 1080/23.98p]/[PH 1080/50.00i]
 - [HA] : Scenes recorded in [HA 1080/59.94i]/[HA 1080/50.00i]
 - [HE] : Scenes recorded in [HE 1080/59.94i]/[HE 1080/50.00i]
 - [PM] : Scenes recorded in [PM 720/59.94p]/[PM 720/50.00p]
 - [SA] : Scenes recorded in [SA 480/59.94i]/[SA 576/50.00i]

(To set this unit to Still Picture Playback Mode)

Touch the still picture (JPEG) F



5 Touch the scene or the still picture to be played back.

- Next (Previous) page can be displayed by touching ▲ / ▼.

6 Select the playback operation by touching the operation icon.



G Operation icon

- If you touch the screen while an operation icon is being displayed or do not touch the icon for a certain period, it will disappear. To display again, touch the screen.

| Motion picture playback | Still picture playback |
|---|---|
| <p>▶/ : Playback/Pause</p> <p>◀◀: Fast rewind playback*</p> <p>▶▶: Fast forward playback*</p> <p>■: Stops the playback and shows the thumbnails.</p> | <p>▶/ : Slide show (playback of the still pictures in numerical order) start/pause.</p> <p>◀ : Plays back the previous picture.</p> <p> ▶: Plays back the next picture.</p> <p>■: Stops the playback and shows the thumbnails.</p> |

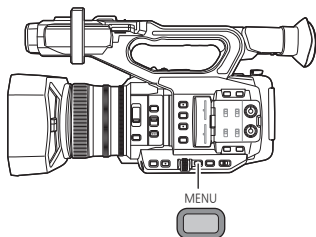

* When touched twice, the fast forward/fast rewind speed increases. (Screen display will change to ◀◀◀ / ▶▶▶ .)

Using the menu screen

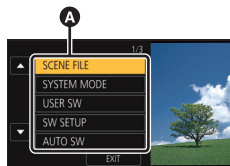

- 1 Press the MENU button .
- 2 Touch the top menu **A**.



- 3 Touch the submenu **B**.
 - Next (Previous) page can be displayed by touching  / .

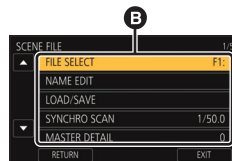

- 4 Touch the desired item to enter the setting.
- 5 Touch [EXIT] to exit the menu setting.

Menu structure

Please refer to "Operating Instructions" (PDF format) for details.

■ Menu structure in Recording mode

| | |
|---------------------|---|
| Scene file | [FILE SELECT]/[NAME EDIT]/[LOAD/SAVE]/[SYNCHRO SCAN]/ [MASTER DETAIL]/[DETAIL CORING]/[SKIN TONE DTL]/ [V DETAIL LEVEL]/[RB GAIN CONTROL SETTING]/ [CHROMA LEVEL]/[CHROMA PHASE]/[MATRIX]/[COLOR CORRECTION SETTING]/[MASTER PED]/[GAMMA MODE]/ [BLACK GAMMA]/[KNEE MODE]/[KNEE MASTER POINT]/ [KNEE MASTER SLOPE]/[DRS]/[DRS EFFECT]/ [AUTO IRIS LEVEL]/[AUTO IRIS LEVEL EFFECT]/[NR CONTROL] |
| System mode | [SYSTEM FREQ]/[REC MODE]/[REC FORMAT]/[ASPECT CONVERT]/[EXTENDED SENSITIVITY]/[HIGH SENS. MODE]/ [FLASH BAND COMPENSATION]/[CAMERA NUMBER SET] |
| User switch | [USER1]/[USER2]/[USER3]/[USER4]/[USER5]/[USER6]/[USER7]/ [USER8]/[USER9]/[USER10]/[USER11]/[USER12]/[USER13]/ [USER BUTTON DISPLAY] |
| Switch setting | [IRIS RING]/[LOW GAIN]/[MID GAIN]/[HIGH GAIN]/[SUPER GAIN]/ [O.I.S.]/[HYBRID O.I.S.]/[CUSTOM O.I.S.]/[BLUR AMPLITUDE]/ [BLUR FREQUENCY]/[ATW SET]/[ATW TARGET R]/ [ATW TARGET B]/[WB PRESET]/[WB VAR]/[MF ASSIST]/[FOCUS ASSIST 1]/[FOCUS ASSIST 2]/[PEAKING COLOR]/ [PEAKING LEVEL]/[FOCUS RING DRIVE]/[FOCUS MACRO]/ [AREA MODE]/[CUSTOM AF]/[AF SPEED]/[AF SENSITIVITY]/[AF AREA WIDTH]/[WFM]/[WFM TYPE]/[WFM POSITION]/[ZEBRA]/ [ZEBRA MODE]/[BARS TYPE]/[SUB REC BUTTON]/ [FAST ZOOM]/[SUB ZOOM]/[DIGITAL ZOOM]/[i.Zoom]/[ZOOM/ FOCUS] |
| Auto switch setting | [A.IRIS]/[AGC]/[AGC LIMIT]/[AUTO SHUTTER]/[AUTO SLOW SHTR]/[ATW]/[AF] |
| Recording Setup | [MEDIA SELECT]/[2 SLOTS FUNC.]/[DUAL CODEC REC]/ [INTERVAL REC]/[VFR MODE]/[FRAME RATE]/[SUPER SLOW REC]/[PRE-REC]/[INFRARED REC]/[IR REC COLOR]/ [FOCUS TRANSITION]/[FOCUS TRANSITION TIME]/ [FOCUS TRANSITION REC]/[FOCUS TRANSITION WAIT]/[TIME STAMP]/[DF MODE]/[TCG]/[TC PRESET]/[UB PRESET] |
| Audio Setup | [AUDIO LOW CUT CH1]/[AUDIO LOW CUT CH2]/[AUDIO LEVEL CH1]/[AUDIO LEVEL CH2]/[AUDIO ALC LINK]/[AUDIO ALC CH1]/ [AUDIO ALC CH2]/[INPUT1 LINE LEVEL]/[INPUT2 LINE LEVEL]/ [INPUT1 MIC LEVEL]/[INPUT2 MIC LEVEL] |
| Output Setup | [RESOLUTION]/[REMOTE REC]/[REMOTE REC LINK]/[DOWN CONV.]/[HDMI UHD OUTPUT LIMIT]/[HDMI TC OUTPUT]/[AV OUT]/[H/PHONE MODE]/[VOLUME]/[TEST TONE]/[LCD/EVF OUTPUT] |

| | |
|-----------------|---|
| Display setting | [ZEBRA DETECT 1]/[ZEBRA DETECT 2]/[MARKER]/[GUIDE LINES]/[SAFETY ZONE]/[CENTER MARKER]/[REC COUNTER]/[FOCUS DISPLAY]/[ZOOM DISPLAY]/[VIDEO OUT OSD]/[DATE/TIME]/[DATE FORMAT]/[LEVEL GAUGE]/[AUDIO LEVEL METER]/[LENS STATUS]/[CARD & BATTERY]/[OTHER DISPLAY]/[POWER LCD]/[LCD SET]/[EVF SETTING]/[EYE SENSOR]/[SELF SHOOT]/[EVF COLOR]/[EVF/LCD DETAIL]/[EVF/LCD PEAK LEVEL]/[EVF/LCD PEAK FREQ.] |
| Other Functions | [FORMAT MEDIA]/[MEDIA STATUS]/[REC LAMP]/[CLOCK SET]/[TIME ZONE]/[ALERT SOUND]/[ECONOMY (BATT)]/[ECONOMY (AC)]/[USB MODE]/[USB MODE SELECT]/[INITIAL SET]/[NUMBER RESET]/[SOFTWARE INFO]/[LANGUAGE] |
| Network Setup | [USER ACCOUNT]/[WIRELESS SETUP]/[Wireless LAN setup]/[CONNECTION HISTORY]/[NETWORK INITIAL SETTING]/[NETWORK SETUP PASSWORD] |
| Maintenance | [VERSION]/[UPDATE]/[HOUR METER] |

■ Menu structure in Playback mode

| | |
|-----------------------------|---|
| Video Setup* ¹ | [REPEAT PLAY]/[RESUME PLAY]/[SCENE PROTECT]/[DELETE] |
| Picture Setup* ² | [SCENE PROTECT]/[DELETE] |
| Copy | [COPY ONCE]* ³ /[SELECT COPY] |
| User switch | [USER1]/[USER2]/[USER3]/[USER4]/[USER5]/[USER6]/[USER7]/[USER8]/[USER9] |
| Output Setup | [RESOLUTION]/[DOWN CONV.]/[HDMI UHD OUTPUT LIMIT]/[HDMI TC OUTPUT]* ¹ /[AV OUT]/[LCD/EVF OUTPUT] |
| Display setting | [VIDEO OUT OSD]/[DATE/TIME]/[DATE FORMAT]/[AUDIO LEVEL METER]* ¹ /[CARD & BATTERY]/[OTHER DISPLAY]/[POWER LCD]/[LCD SET]/[EVF SETTING]/[EYE SENSOR]/[EVF COLOR] |
| Other Functions | [FORMAT MEDIA]/[MEDIA STATUS]/[PICTURE MEDIA SELECT]/[CLOCK SET]/[TIME ZONE]/[ALERT SOUND]/[ECONOMY (BATT)]/[ECONOMY (AC)]/[SYSTEM FREQ]/[USB MODE]/[USB MODE SELECT]/[INITIAL SET]/[NUMBER RESET]/[SOFTWARE INFO]/[LANGUAGE] |
| Network Setup | [USER ACCOUNT]/[WIRELESS SETUP]/[Wireless LAN setup]/[CONNECTION HISTORY]/[NETWORK INITIAL SETTING]/[NETWORK SETUP PASSWORD] |
| Maintenance | [VERSION]/[UPDATE]/[HOUR METER] |

*1 The items are available in Motion Picture Playback Mode.

*2 The items are available in Still Picture Playback Mode.

*3 Only when connected to an external media device.

Troubleshooting

■ It is not a malfunction in following cases

| | |
|--|---|
| The lens, the viewfinder or LCD monitor fog up. | <ul style="list-style-type: none"> • This is due to condensation. This is not a malfunction. Please refer to page 8. |
| Object seems to be warped. | <ul style="list-style-type: none"> • Object seems to be warped slightly when the object moves across the image very fast, but this is because the unit is using MOS for the image sensor. This is not a malfunction. |



Power

| Problem | Check points |
|---|--|
| <p>This unit cannot be turned on.</p> <p>This unit does not stay on long enough.</p> <p>Battery runs down quickly.</p> | <ul style="list-style-type: none"> • Charge the battery again to ensure it is sufficiently charged. (→ 19) • In cold places, the battery using time becomes shorter. • The battery has a limited life. If the operating time is still too short even after the battery is fully charged, the battery has worn out and needs to be replaced. |
| <p>This unit cannot be operated though it is turned on.</p> <p>This unit does not operate normally.</p> | <ul style="list-style-type: none"> • Remove the battery or AC adaptor, wait about 1 minute and then reconnect the battery or AC adaptor. Then about 1 minute later, turn on the unit again. (Conducting the above operation while the SD card is being accessed may damage the data on the media.) • If normal operation is still not restored, detach the power connected, and consult the dealer who you purchased this unit from. |

Recording

| Problem | Check points |
|--|---|
| <p>The unit arbitrarily stops recording.</p> | <ul style="list-style-type: none"> ● Use an SD card that can be used for motion picture recording. (→ 23) ● The recordable time may have shortened due to the deterioration of the data writing speed or repeated recording and deletion. Using the unit, format the SD card. (→ 29) |
| <p>Color or brightness of the image changes, or you may see horizontal bars in the image.</p> <p>The LCD monitor flickers indoors.</p> | <ul style="list-style-type: none"> ● Color or brightness of the image may change, or you may see horizontal bars in the image when the object is recorded under fluorescent light, mercury light or sodium light, etc., but this is not a malfunction. ● Change settings as follows: <ul style="list-style-type: none"> – Set this unit to Auto Shutter Mode. – Adjust the shutter speed to 1/50, 1/60 or 1/100. ● Adjust the Synchro Scan shutter speed. |

Playback

| Problem | Check points |
|--|---|
| <p>Scenes/still pictures cannot be played back.</p> | <ul style="list-style-type: none"> ● Any scenes/still pictures where the thumbnails are displayed as  cannot be played back. ● In most cases,  is displayed for the following scenes: <ul style="list-style-type: none"> – Scenes recorded with another device or edited with editing software – Scenes with damaged data ● The thumbnails of scenes with a different system frequency are indicated with . You can play them back by changing the [SYSTEM FREQ] setting. (→ 29) |

Please refer to “Operating Instructions (PDF format)” for details.

About copyright

■ Carefully observe copyright laws

Recording of pre-recorded tapes or discs or other published or broadcast material for purposes other than your own private use may infringe copyright laws. Even for the purpose of private use, recording of certain material may be restricted.

■ Licenses

- SDXC Logo is a trademark of SD-3C, LLC.
- "AVCHD", "AVCHD Progressive" and the "AVCHD Progressive" logo are trademarks of Panasonic Corporation and Sony Corporation.
- Manufactured under license from Dolby Laboratories. Dolby and the double-D symbol are trademarks of Dolby Laboratories.
- The terms HDMI and HDMI High-Definition Multimedia Interface, and the HDMI Logo are trademarks or registered trademarks of HDMI Licensing, LLC in the United States and other countries.
- LEICA is a registered trademark of Leica Microsystems IR GmbH.
- DICOMAR is a registered trademark of Leica Camera AG.
- iPad is a trademark of Apple Inc., registered in the U.S. and other countries.
- Other names of systems and products mentioned in these instructions are usually the registered trademarks or trademarks of the manufacturers who developed the system or product concerned.

This product is licensed under the AVC Patent Portfolio License for the personal use of a consumer or other uses in which it does not receive remuneration to (i) encode video in compliance with the AVC Standard ("AVC Video") and/or (ii) decode AVC Video that was encoded by a consumer engaged in a personal activity and/or was obtained from a video provider licensed to provide AVC Video. No license is granted or shall be implied for any other use. Additional information may be obtained from MPEG LA, L.L.C. See <http://www.mpegla.com>

This product incorporates the following software: (1) the software developed independently by or for Panasonic Corporation, (2) the software owned by third party and licensed to Panasonic Corporation, (3) the software licensed under the GNU General Public License, Version 2.0 (GPL V2.0), (4) the software licensed under the GNU LESSER General Public License, Version 2.1 (LGPL V2.1), and/or (5) open source software other than the software licensed under the GPL V2.0 and/or LGPL V2.1.

The software categorized as (3) - (5) are distributed in the hope that it will be useful, but WITHOUT ANY WARRANTY, without even the implied warranty of MERCHANTABILITY or FITNESS FOR A PARTICULAR PURPOSE. Refer to the detailed terms and conditions thereof, which can be accessed by selecting [SOFTWARE INFO] in "Other Functions" as described in "Using the Menu" in the Operating Instructions (PDF format).

At least three (3) years from delivery of this product, Panasonic will give to any third party who contacts us at the contact information provided below, for a charge no more than our cost of physically performing source code distribution, a complete machine-readable copy of the corresponding source code covered under GPL V2.0 or LGPL V2.1, as well as the respective copyright notice thereof.

Contact Information:
oss-cd-request@gg.jp.panasonic.com

The source code and the copyright notice are also available for free in our website below.
<http://panasonic.net/avc/oss/index.html>

Specification

4K Video Camera

General

Power:

DC 7.28 V (When using battery)

DC 12 V (When using AC adaptor)

Power consumption:

19.7 W (When using LCD monitor)



indicates safety information

Ambient operating temperature:

0 °C to 40 °C

Ambient operating humidity:

10%RH to 80%RH (no condensation)

Mass:

Approx. 2.0 kg

(body only, excluding lens hood, battery, and accessories)

Approx. 2.4 kg

(including lens hood, supplied battery, and eye cup)

Dimensions (W×H×D):

173 mm×195 mm×346 mm

(excluding eye cup and projecting parts)

Camera unit

Pickup device:

1.0-type (effective size) MOS solid state image sensor

Number of pixels:

FHD (1920×1080), UHD (3840×2160);

8.79 million pixels

4K (4096×2160) 24.00p; 9.46 million pixels

Lens:

Optical image stabilizer lens, optical 20× motorized zoom

F value (focal length)

F2.8 to F4.5 (f=8.8 mm to 176 mm)

35 mm conversion

FHD (1920×1080), UHD (3840×2160);

25.4 mm to 508.0 mm

4K (4096×2160) 24.00p;

24.0 mm to 480.0 mm

Filter diameter; 67 mm

ND filter; OFF, 1/4, 1/16, 1/64

Shortest shooting distance (M.O.D.);

1.0 m from the lens

IR filter; incorporates the ON/OFF control function

Gain setting:

L/M/H selector button (toggle button)

In normal mode; 0 dB to 24 dB

When [EXTENDED SENSITIVITY] is enabled;

−3 dB to 24 dB

- Adjustable in 1 dB steps (automatic setting can also be assigned to L/M/H.)
- When assigning [SUPER GAIN] to the USER button: 30 dB or 36 dB

Color temperature setting:

[ATW], [ATW LOCK], [Ach], [Bch],

preset 3200K, preset 5600K, VAR (2000K to 15000K)

Shutter speed:

When [SYSTEM FREQ] = [59.94Hz]

- 60i/60p mode;
 - 1/60, 1/100, 1/120, 1/180, 1/250, 1/350,
 - 1/500, 1/750, 1/1000, 1/1500, 1/2000,
 - 1/3000, 1/4000, 1/8000 sec.
- 30p mode;
 - 1/30, 1/50, 1/60, 1/100, 1/120, 1/180, 1/250,
 - 1/350, 1/500, 1/750, 1/1000, 1/1500, 1/2000,
 - 1/3000, 1/4000, 1/8000 sec.
- 24p mode;
 - 1/24, 1/48, 1/50, 1/60, 1/100, 1/120, 1/180,
 - 1/250, 1/350, 1/500, 1/750, 1/1000, 1/1500,
 - 1/2000, 1/3000, 1/4000, 1/8000 sec.

When [SYSTEM FREQ] = [50.00Hz]

- 50i/50p mode;
 - 1/50, 1/60, 1/100, 1/125, 1/180, 1/250,
 - 1/350, 1/500, 1/750, 1/1000, 1/1500, 1/2000,
 - 1/3000, 1/4000, 1/8000 sec.
- 25p mode;
 - 1/25, 1/50, 1/60, 1/100, 1/125, 1/180, 1/250,
 - 1/350, 1/500, 1/750, 1/1000, 1/1500, 1/2000,
 - 1/3000, 1/4000, 1/8000 sec.

Slow shutter speed:

When [SYSTEM FREQ] = [59.94Hz]

- 60i/60p mode;
 - 1/2, 1/4, 1/8, 1/15, 1/30 sec.
- 30p mode;
 - 1/2, 1/4, 1/8, 1/15 sec.
- 24p mode;
 - 1/2, 1/3, 1/6, 1/12 sec.

When [SYSTEM FREQ] = [50.00Hz]

- 50i/50p mode;
 - 1/2, 1/3, 1/6, 1/12, 1/25 sec.
- 25p mode;
 - 1/2, 1/3, 1/6, 1/12 sec.

Synchro scan shutter:

When [SYSTEM FREQ] = [59.94Hz]

- 59.94i/59.94p;
 - 1/60.0 to 1/249.7 sec.
- 29.97p;
 - 1/30.0 to 1/249.7 sec.
- 23.98p;
 - 1/24.0 to 1/249.6 sec.
- 24.00p;
 - 1/24.0 to 1/249.9 sec.

When [SYSTEM FREQ] = [50.00Hz]

- 50i/50p;
 - 1/50.0 to 1/250.0 sec.
- 25p;
 - 1/25.0 to 1/250.0 sec.

VFR recording frame rate:

When [SYSTEM FREQ] = [59.94Hz]

- 30p mode;
 - 2, 15, 26, 28, 30, 32, 34, 45, 60 (fps)
- 24p mode;
 - 2, 12, 20, 22, 24, 26, 28, 36, 48, 60 (fps)

When [SYSTEM FREQ] = [50.00Hz]

- 25p mode;
 - 2, 12, 21, 23, 25, 27, 30, 37, 50 (fps)

Super Slow Recording:

When [SYSTEM FREQ] = [59.94Hz]

Recording frame rate; FHD 120 fps
 Slow motion effect;
 1/4 the normal speed (30p mode),
 1/5 the normal speed (24p mode)

When [SYSTEM FREQ] = [50.00Hz]

Recording frame rate; FHD 100 fps
 Slow motion effect;
 1/4 the normal speed (25p mode)

Sensitivity:

When [HIGH SENS. MODE] = [HIGH SENS.]

F11 (2000 lx, 3200 K, 89.9% reflection,
 1080/59.94i)

F12 (2000 lx, 3200 K, 89.9% reflection,
 1080/50.00i)

Minimum subject illumination:

0.2 lx (F2.8, gain 18 dB,
 shutter speed 1/2 sec.,
 when [HIGH SENS. MODE] = [HIGH SENS.]

Digital zoom:

2×/5×/10×/i.Zoom (max. 30×)

Lens hood:

Hood with lens cover

Memory card recorder

Recording media:

SDHC Memory Card (4 GB to 32 GB)/
SDXC Memory Card (48 GB to 128 GB);
UHS-I supported

Refer to page 23 for details on SD cards usable
in this unit.

Recording slots:

2 slots

System frequency:

59.94 Hz, 50.00 Hz

Motion picture recording:

Recording method; MOV, MP4, AVCHD
Recording format;

- When [REC MODE] = [MOV], [MP4]
[4K 2160/24.00p 100M];
Average 100 Mbps (VBR)

(When [SYSTEM FREQ] = [59.94Hz])

[UHD 2160/59.94p 150M];

Average 150 Mbps (VBR)

[UHD 2160/29.97p 100M]/

[UHD 2160/23.98p 100M];

Average 100 Mbps (VBR)

[FHD 1080/59.94p ^{ALL-I}_{200M}]/

[FHD 1080/29.97p ^{ALL-I}_{200M}]/

[FHD 1080/23.98p ^{ALL-I}_{200M}];

Average 200 Mbps (VBR)

[FHD 1080/59.94p 100M];

Average 100 Mbps (VBR)

[FHD 1080/59.94p 50M]/

[FHD 1080/29.97p 50M]/

[FHD 1080/23.98p 50M]/

[FHD 1080/59.94i 50M];

Average 50 Mbps (VBR)

(When [SYSTEM FREQ] = [50.00Hz])

[UHD 2160/50.00p 150M];

Average 150 Mbps (VBR)

[UHD 2160/25.00p 100M];

Average 100 Mbps (VBR)

[FHD 1080/50.00p ^{ALL-I}_{200M}]/

[FHD 1080/25.00p ^{ALL-I}_{200M}];

Average 200 Mbps (VBR)

[FHD 1080/50.00p 100M];

Average 100 Mbps (VBR)

[FHD 1080/50.00p 50M]/

[FHD 1080/25.00p 50M]/

[FHD 1080/50.00i 50M];

Average 50 Mbps (VBR)

- When [REC MODE] = [AVCHD]

(When [SYSTEM FREQ] = [59.94Hz])

[PS 1080/59.94p]; Average 25 Mbps (VBR)

[PH 1080/59.94i]; Average 21 Mbps (VBR)

[PH 1080/23.98p]; Average 21 Mbps (VBR)

[HA 1080/59.94i]; Average 17 Mbps (VBR)

[HE 1080/59.94i]; Average 5 Mbps (VBR)

[PM 720/59.94p]; Average 8 Mbps (VBR)

[SA 480/59.94i]

(When [ASPECT CONVERT] = [SIDE

CROP], [SQUEEZE]);

Average 9 Mbps (VBR)

(When [SYSTEM FREQ] = [50.00Hz])

[PS 1080/50.00p]; Average 25 Mbps (VBR)

[PH 1080/50.00i]; Average 21 Mbps (VBR)

[HA 1080/50.00i]; Average 17 Mbps (VBR)

[HE 1080/50.00i]; Average 5 Mbps (VBR)

[PM 720/50.00p]; Average 8 Mbps (VBR)

[SA 576/50.00i]

(When [ASPECT CONVERT] = [SIDE

CROP], [SQUEEZE]);

Average 9 Mbps (VBR)

Refer to "Operating Instructions" (PDF format)
for the picture size and recordable time of a
motion picture.

Still picture recording:

Recording method;

JPEG corresponding DCF (Design rule for
Camera File system, based on Exif 2.2 standard)

Refer to "Operating Instructions" (PDF format)
for picture size of a still picture and number of
recordable pictures.

2 Slot function:

Relay, simultaneous, background*1, dual codec

*1 Available with a recording format of
50 Mbps or less

Digital video

Video signal for external output:

8 bit 4:2:2*2

*2 It is set to 8 bit 4:2:0 when UHD 59.94p or UHD 50.00p is selected.

Recording video signal:

8 bit 4:2:0

Video compression format:

MPEG-4 AVC/H.264 High Profile
(MOV/MP4/AVCHD)

Digital audio

Recording audio signal:

48 kHz/16 bit 2CH

Audio compression format:

Linear PCM (MOV/MP4), Dolby Digital
(AVCHD)

Headroom:

12 dB

Dual codec

Recording method:

MOV, MP4

Video compression format:

MPEG-4 AVC/H.264 High Profile

Audio compression format:

Linear PCM

Recording format:

When [DUAL CODEC REC] = [FHD 50Mbps]

- For main recording

[REC MODE] = [MOV]/[MP4]

[UHD 2160/29.97p 100M],

[UHD 2160/25.00p 100M],

[UHD 2160/23.98p 100M];

Average 100 Mbps (VBR)

- For sub recording

[REC MODE] = [MOV]/[MP4]*3

FHD 29.97p, 25.00p, 23.98p*4;

Average 50 Mbps (VBR)

When [DUAL CODEC REC] = [FHD 8Mbps]

- For main recording

[REC MODE] = [MOV]/[MP4]

[UHD 2160/29.97p 100M],

[UHD 2160/25.00p 100M],

[UHD 2160/23.98p 100M],

Average 100 Mbps (VBR)

[FHD 1080/59.94p

[FHD 1080/50.00p

[FHD 1080/29.97p

[FHD 1080/25.00p

[FHD 1080/23.98p

Average 200 Mbps (VBR)

[FHD 1080/59.94p 100M],

[FHD 1080/50.00p 100M];

Average 100 Mbps (VBR)

- For sub recording

[REC MODE] = [MOV]

FHD 59.94p, 50.00p, 29.97p, 25.00p,

23.98p*4;

Average 8 Mbps (VBR)

*3 It records motion picture with the same [REC MODE] setting selected for main recording.

*4 It records motion picture in the same frame rate as that of the [REC FORMAT] setting selected for main recording.

Video input/output

VIDEO OUT terminal:

VIDEO OUT terminal × 1

HDMI OUT terminal:

HDMI × 1,

(HDMI Type A, not compatible with

VIERA Link)

Output format:

2160/59.94p/50.00p/29.97p/25.00p/24.00p/

23.98p, 1080/59.94p/50.00p/29.97p/25.00p/

24.00p/23.98p/59.94i/50.00i, 720/59.94p/

50.00p, 480/59.94p, 576/50.00p

Audio input

Built-in microphone:

Supports stereo microphone

AUDIO INPUT1/AUDIO INPUT2 terminal:

XLR×2, 3-pin

Input high impedance, LINE/MIC/MIC+48 V (switch selection)

- LINE; +4 dBu/0 dBu (selectable menu)
- MIC; -40 dBu / -50 dBu / -60 dBu (selectable menu)

Audio output

HDMI OUT terminal:

2ch (Linear PCM)

AUDIO OUT terminal:

AUDIO OUT terminal ×2

Output level; 251 mV

Output impedance; 600 Ω

Headphone output terminal:

3.5 mm diameter stereo mini jack×1

Speaker:

Round type speaker with a diameter of 20 mm ×1

Other input/output

CAM REMOTE terminal:

2.5 mm diameter super mini jack×1 (ZOOM, S/S)

3.5 mm diameter mini jack×1 (FOCUS, IRIS)

USB HOST terminal:

Type A connector, 9-pin

In Recording mode;

USB 2.0 compatible (5 V, 0.5 A)

In Playback mode;

USB 3.0 compatible (5 V, 0.9 A), used for external media device connection*5, bus power supported

*5 External media device with a capacity of 32 GB or below or a capacity above 2 TB cannot be used

USB DEVICE terminal:

Type Micro B connector, 10-pin, USB 3.0 compatible, used for the mass storage function (read only)

DC input terminal:

DC 12 V (DC 11.4 V to 12.6 V), EIAJ type 4

Monitor

LCD monitor:

8.8 cm (3.5 ") liquid crystal monitor (Approx. 1150000 dots)

Viewfinder:

1.0 cm (0.39 ") OLED (organic EL display) (Approx. 2360000 dots, video display area; Approx. 1770000 dots)

AC adaptor

Power source:

AC \sim 100 V to 240 V,
50 Hz/60 Hz, 1.2 A

Power output:

DC \equiv 12 V, 3.0 A

 indicates safety information

Ambient operating temperature:

0 °C to 40 °C

Ambient operating humidity:

10%RH to 90%RH (no condensation)

Mass:

Approx. 225 g

Dimensions (W×H×D):

115 mm×37 mm×57 mm
(Excluding the DC cord portion)

Battery charger

Input voltage:

DC \equiv 12 V, 3.0 A

Output voltage:

DC \equiv 8.4 V, 4.0 A

 indicates safety information

Charging current:

Max. 4000 mA

Ambient operating temperature:

0 °C to 40 °C

Ambient operating humidity:

10%RH to 80%RH (no condensation)



Mass:

Approx. 230 g

Dimensions (W×H×D):

130 mm×48 mm×107 mm

The symbols on this product (including the accessories) represent the following:

| | |
|---|---|
|  | AC |
|  | DC |
|  | Class II equipment (The construction of the product is double-insulated.) |

Panasonic Warranty

- Subject to the conditions of this warranty Panasonic or its Authorised Service Centre will perform necessary service on the product, without charge for parts or labour, if in the opinion of Panasonic the product is found to have a manufacturing defect within one (1) year or (12 months) (the "warranty period") from the date of purchase appearing on your purchase receipt.
- This warranty only applies to Panasonic products purchased in Australia and sold by Panasonic Australia, its Authorised Distributors, or Dealers, and only where the products are used and serviced within Australia or its territories. Warranty cover only applies to the services that are carried out by a Panasonic Authorised Service Centre and only if valid proof of purchase is presented when the warranty service is requested.
- This warranty only applies if the product has been installed and/or used in accordance with the manufacturer's recommendations (as noted in the operating instructions) under normal use and reasonable care (in the opinion of Panasonic). The warranty does not cover damage, malfunction or failure resulting from use of incorrect voltages, incorrect installation, accident, misuse, neglect, build-up of dirt or dust, abuse, maladjustment of customer controls, mains supply problems, thunderstorm activity, infestation by insects or vermin, tampering or repair by unauthorised persons (including unauthorised alterations), exposure to abnormally corrosive conditions, or any foreign object or matter having entered the product.
- This warranty does not cover the following items unless the fault or defect existed at the time of purchase:
 - Consumable parts
 - Cosmetic parts
 - Worn or damaged parts
 - Information stored on Hard Disk Drives, Optical Discs, USB Devices, SD Cards, Tapes
 - DTV reception issues caused by TV Aerial / Cabling / Wall socket(s)
- Some products may be supplied with Ethernet connection hardware. The warranty is limited on such products and will not cover:
 - Internet and or DLNA connection / setup related problems
 - Access fees and or charges incurred for internet connection
 - Incompatible software or software not specifically stipulated in the product operations manual; and
 - Any indirect or consequential costs associated with the incorrect use or misuse of the hardware, its connection to the internet or any other device.
- To claim warranty service, when required, you should:
 - Contact Panasonic's Customer Care Centre on 132 600 for Service Centre information.
 - Confirm the opening and acceptance times with the Authorised Service centre that you choose.
 - Then send or take the product to a Panasonic Authorised Service Centre together with your proof of purchase receipt.
 - Any freight and insurance costs associated with the transport of the product to and/or from your nearest Authorised Service Centre must be arranged and paid for by you.
- The warranties hereby conferred do not extend to, and exclude, any costs associated with the installation, de-installation or re-installation of a product, including costs related to the mounting, de-mounting or remounting of any screen, (and any other ancillary activities), delivery, handling, freighting, transportation or insurance of the product or any part thereof or replacement of and do not extend to, and exclude, any damage or loss occurring by reason of, during, associated with, or related to such installation, de-installation, re-installation or transit.

Panasonic Authorised Service Centres are located in major metropolitan areas and most regional centres of Australia, however, coverage will vary dependant on product. For advice on exact Authorised Service Centre locations for your product, please telephone our Customer Care Centre on 132600 or visit our website and use the Service Centre Locator.

In addition to your rights under this warranty, Panasonic products come with consumer guarantees that cannot be excluded under the Australian Consumer Law. If there is a major failure with the product, you can reject the product and elect to have a refund or to have the product replaced or if you wish you may elect to keep the goods and be compensated for the drop in value of the goods. You are also entitled to have the product repaired or replaced if the product fails to be of acceptable quality and the failure does not amount to a major failure.

If there is a major failure in regard to the product which cannot be remedied then you must notify us within a reasonable period by contacting the Panasonic Customer Care Centre. If the failure in the product is not a major failure then Panasonic may choose to repair or replace the product and will do so in a reasonable period of time from receiving notice from you.

THIS WARRANTY CARD AND THE PURCHASE DOCKET (OR SIMILAR PROOF OF PURCHASE) SHOULD BE RETAINED BY THE CUSTOMER AT ALL TIMES

If you require assistance regarding warranty conditions or any other enquiries, please visit the Panasonic Australia website www.panasonic.com.au or contact by phone on **132 600**
If phoning in, please ensure you have your operating instructions available.

Panasonic Australia Pty. Limited

ACN 001 592 187 ABN 83 001 592 187
 1 Innovation Road, Macquarie Park NSW 2113
www.panasonic.com.au

Manufactured by: Panasonic Corporation
Kadoma, Osaka, Japan
Importer for Europe: Panasonic Marketing Europe GmbH
Panasonic Testing Centre
Winsbergring 15, 22525 Hamburg, Germany



Panasonic Corporation
Web site: <http://www.panasonic.com>

© Panasonic Corporation 2016

DVQX1102YA
F116YF1078