

Panasonic®

Operating and Installation Instructions

DISHWASHER

Household Use

Model No. : NP-6X3MSQNZ
NP-6V3MUQNZ

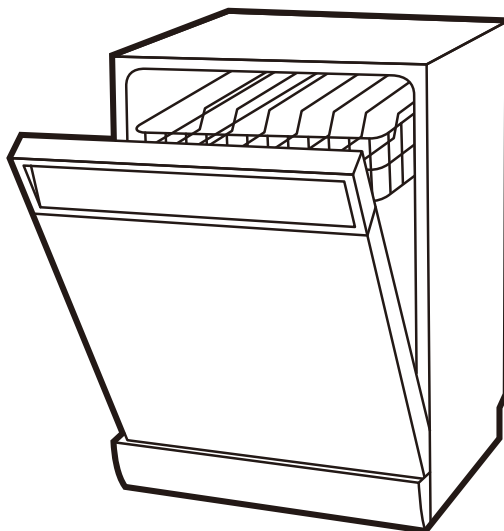

Thank you for purchasing this Panasonic product.

- This appliance is intended for household use only.
- Please read these instructions carefully before attempting to install, operate or service this product.
- For optimum performance and safety, please read these instructions carefully and follow safety precautions when using this product.
- This unit contains reusable materials, so please assist in proper disposal or recycling when discarding them to protect the environment.
- Before using this product **please pay extra attention to “Safety Precautions” (Page 3 - 5).**

Keep these Operating and Installation Instructions for future use.

Table of Contents

Safety Precautions	3 - 5
Precautions for Use	6
Confirmation and Preparation before Use	7 - 8
Parts Identification	9 - 10
Quick Operation Guide	11
Instructions for Use.....	12 - 18
• Loading the Dishwasher.....	12 - 13
• Adding Detergent	14 - 15
• Starting a Programme	16 - 18
Cleaning and Maintenance.....	19 - 21
Troubleshooting	22 - 24
Specifications	25 - 26

For Installer

Installation Instructions	27 - 29
• Positioning the Dishwasher	27
• Electrical Requirements	27
• Electrical Connection.....	27
• Water Supply Connection	28
Checkpoints After Installation	29

Safety Precautions

Make sure to follow these instructions

In order to prevent accidents or injuries to the users, other people, and damage to property, please follow the instructions below.

■ The following charts indicate the degree of damage caused by wrong operation.



WARNING Indicate serious injury or death.



CAUTION Indicate risk of injury or property damage.

■ The symbols are classified and explained as follows.



These symbols indicate prohibition.



This symbol indicates requirement that must be followed.



This symbol indicates an action that should be performed carefully.



WARNING

To prevent fire, burns or electric shock

This appliance is not intended for use by persons (including children) with reduced physical, sensory or mental capabilities, or lack of experience and knowledge, unless they have been given supervision or instruction concerning use of the appliance by a person responsible for their safety. Children should be supervised to ensure that they do not play with the appliance.



- **Do not splash or sprinkle water on the appliance body.**
(It may cause fire or electric shock.)



- **Keep the appliance away from a flame or heat sources.**
(So as not to cause fires.)
 - Mosquito coils, cigarettes, candles, electric heaters, etc.



- **Do not use the power cord or power plug incorrectly.**
(So as not to cause fire or electric shock.)
 - Do not damage the cord or plug; do not modify, forcibly bend, twist, pull, load with heavy objects, bundle, or place near heat sources.
 - If the cord or plug is damaged, it must be replaced by the manufacturer, its Service Centre or other relevant qualified persons in order to avoid a hazard.
 - Do not use wet hands to plug or unplug the power plug.
 - Do not use if the cord or plug is damaged.







- **Do not disassemble, repair or modify the appliance.**
(It may cause fire or injury due to abnormal operation.)
 - Contact your dealer for inspection and repair.

Safety Precautions



Make sure to follow these instructions

WARNING

-  • **Do not open the dishwasher during operation or within 30 minutes after the end of the operation.**
(The high temperature inside the appliance, washing water or steam may cause burns.)
→ Please wait for 30 minutes after the end of the operation before opening the dishwasher (to take out the items, carry out cleaning or maintenance).
→ If you need to open the dishwasher during operation, you must pause the operation first and open the door carefully and slowly.
-  • **Do not touch the inside of the appliance or the heater cover within 30 minutes after the end of the programme.**
(So as not to cause a burn injury.)
-  • **Do not bang the appliance while it is in operation.**
(It may cause electric shock, electricity leakage, or short circuit, resulting fire.)
-  • **Ensure at least 15 cm clearance between the appliance and heat sources such as a gas stove.**
(So as not to cause fires.)
-  • **The door should not stay in an open position.**
(as this may cause the utensils to tumble and fall over resulting injuries.)

WARNING

To prevent fire, burns or electric shock

-  • **It shall be grounded. Connect the power plug to a power socket with a grounding continuity terminal.**
(So as not to cause electric shocks in case of malfunction or leakage.)
-  • **Do not use the appliance if the cord or plug is damaged, or if the plug is not securely inserted in the power socket.**
→ Contact your dealer for repair.
-  • **Knives and other utensils with sharp points must be loaded in the basket with their points down or placed in a horizontal position.**
(It may cause cuts.)

Safety Precautions

Make sure to follow these instructions

WARNING

-  • **If abnormality or error occurs, stop using the appliance immediately, close the supply valve and unplug the power plug.**
(It may cause smoking, combustion, or electric shock.)





Examples of abnormality or error

- Sometimes the appliance does not operate after the power is turned on.
- The door does not open or close normally.
- Abnormal sound is heard during operation.
- The appliance body is deformed or becomes abnormally hot.

→ Contact your dealer for repair.

-  • **Please use the power cord and power plug correctly.**
 - Be sure to use a 220-240 V AC power socket separately.
(So as not to cause fires.)
 - The power plug must be fully inserted into the power socket. (Otherwise, it may cause fire due to electric shock or heat. Do not use if the plug is damaged or the socket is loose.)
 - Wipe the plug periodically with a dry cloth. (Dust or moisture built up on the plug may cause poor insulation, resulting fire.)
 - Be sure to unplug the appliance if you do not intend to use it for a long period of time or when you perform cleaning or maintenance.
 - When unplugging the appliance, always hold and pull the plug (instead of pulling the cord) (as it may cause fire due to electric shock or short circuit).

CAUTION

-  • **Do not stay near or touch the drain hose or vent.**
(as the exhaust hot water, hot air or steam may cause burns.)
-  • **Do not forcibly close the door if the utensils protrude from the dishwasher.**
(as this may cause the door to deform or hot water may squirt out resulting burns.)
-  • **Open and close the door carefully to avoid pinching your fingers.**
(which may cause injuries.)
-  • **Do not put anything heavy on the top surface of the appliance.**
(as this may cause the unit to deform due to force.)

Precautions for Use

■ The dishwasher must be used correctly.

- Do not place the dishwasher in a location near electrical appliances such as a TV or radio (which may cause distorted images or noises).
- Do not add water manually.
(So as not to cause leak, structural damage or malfunction alert.)
- Do not use the appliance other than for its washing or drying function.
(Otherwise, it may cause a failure.)
- Do not pull or push the door with force, or hang items on the door.
(So as not to cause structural damage or malfunction alert.)
- Do not use the appliance as a chopping or storage counter.
(So as not to cause structural damage or deformation.)

■ Make sure to use dishwasher detergent.

- Do not use kitchen detergent or baking soda.
(Excessive foam may be generated causing water leakage or malfunction.)
→ Always use dishwasher detergent (referred to as dishwasher tablet or dishwasher powder).
- Any kitchen detergent used for soaking or pre-wash must be completely washed away before the utensils are loaded into the dishwasher.



(In this manual, “X” indicates actions that are incorrect or prohibited while “ O ” indicates actions that are correct or appropriate.)

Note:

- Do not install in a place where freezing may occur (below 0°C).
(If not properly handled after freezing, it may cause damage to the supply valve or pipes.)
→ If draining is required for freezing prevention, please contact Service Centre.
- Do not use if the water contains impurities, as it may cause poor water supply and malfunction.
- This appliance may have a rubber or resin smell for a while after it is purchased.
There are no adverse effects to the human body, and the odour will disappear after a period of time.
- Please use the new inlet and outlet hoses provided with this appliance. Old inlet and outlet hoses should not be reused in order to prevent leakage.
- Before use, remove all protective and packaging materials, such as cushioning and tape from the dishwasher.

Confirmation and Preparation before Use



CAUTION



Avoid tempered glasses
(which may scatter when broken, resulting in injuries.)



Items that are not suitable for the dishwasher.

- Avoid light-weight items that may easily be blown off. (It may cause damage, smoke, burns and odour.)

- Plastic spoons and lid
- Styrofoam containers
- Sponges and dishwashing cloths
- Baby bottle nipples

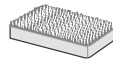
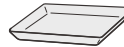

- Avoid non-heat proof items (that are easy to be deformed by heat).

- Plastic items with a heat resistance of 90°C or less
(including items without a heat-proof label).



- Avoid items that are easy to discolour or its coating are easy to peel off.

- Silver, aluminum, copper, iron items
- Wooden (bamboo, rattan) items
- Fluorine processing pans
- Lacquered, gilded, or overglaze-painted items



- Avoid fragile items.

- Cracked, broken items
- Crystal glass, tempered carved glass
- Pans with a wooden handle
- Crackle glaze dinnerware (tableware with crack pattern)



- Avoid items with narrow mouth, the inside of which cannot be washed.

- Bottles and decanters



- Avoid items that are easy to get rusted.

- Iron frying pans, knives



Note:

- Other items that are not mentioned above or which you are not sure whether they should be washed in the dishwasher, please refer to the instructions on the dishwasher detergent or contact the dealer.

Confirmation and Preparation before Use

Preparation

■ Burns and scorches

Utensils with roasted food or steamed eggs, stubborn stains on burnt pans that are difficult to clean.

→ Soak and clean up before loading.



■ Food residues

Fine residue such as seasonings, spices or sesame seeds may re-deposit;

Toothpicks, fish bones or rubber bands may cause valve failure;

Fish skin may cause odour

→ Remove food residues and foreign objects before loading.

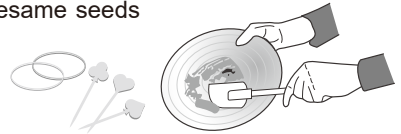

■ Tough soils

May re-deposit

→ Hand wash in advance.



Note:

- The following stains may not be completely removed:
 - Accumulated tea rust
 - Lipstick stains (depends on the types)
 - Plastic tableware stained with food colours
- If the items are stained with food colours (such as ketchup or curry), the pigment may adhere to the inside of the dishwasher. Remove before loading.

Parts Identification

■ Parts Identification

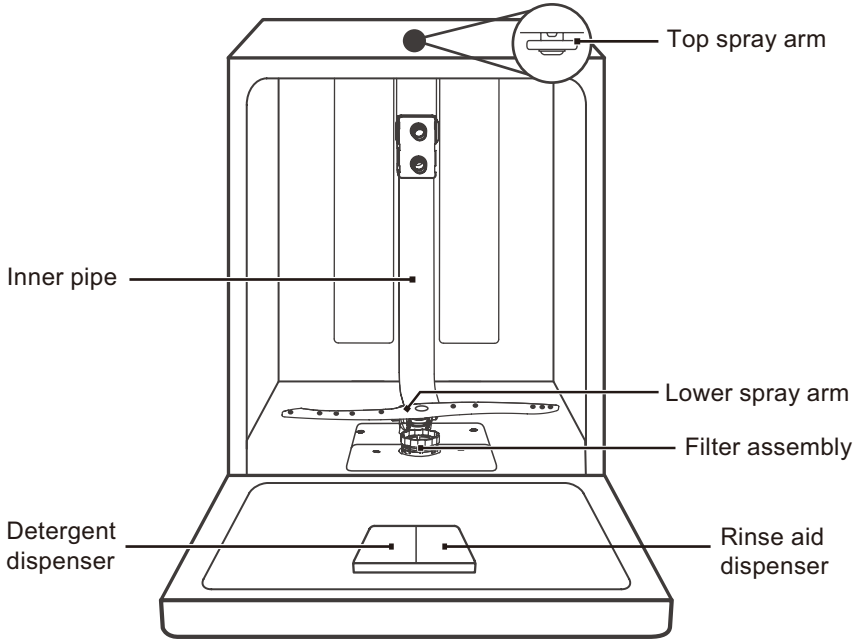

Cutlery rack

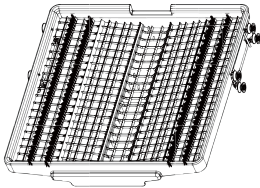

Upper basket

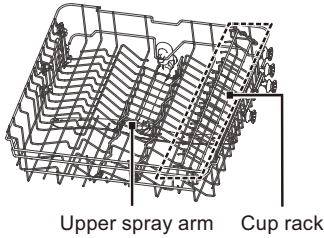

Lower basket

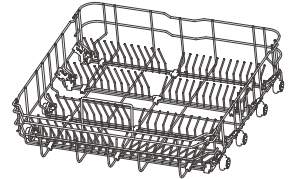

Parts Identification

■ Control Panel

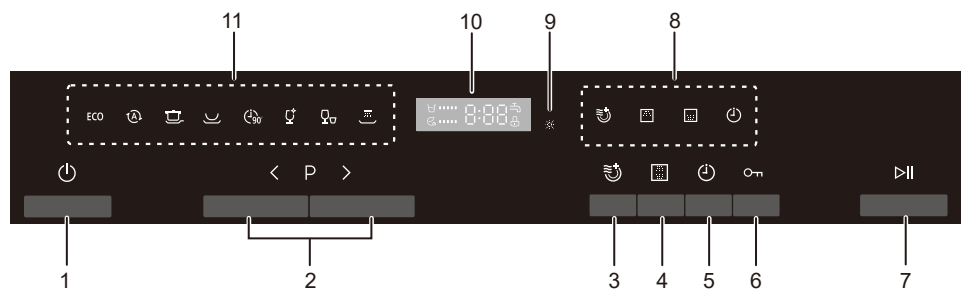

- 1. OFF / ON button:**
To turn OFF / ON the power supply.
- 2. Programme Selection button:**
Press the button to select appropriate programme.
- 3. Extra Dry indicator:**
Only ECO, Intensive, Heavy, 90min, Glass programme have this function.
- 4. Wash Zone button:**
Dual zone wash function, press the button to select to wash either Upper Basket or Lower Basket or both loaded, and the corresponding icon indicator will light up.
- 5. Time Delay button:**
Press the button to delay. User can delay the washing start time from 1 to 24 hours.
- 6. Child Lock button:**
Press and hold the button for 3 seconds to lock/unlock. All buttons are disabled while Child Lock is on except OFF/ON button.
- 7. Start / Pause button:**
To start the selected washing programme or pause the working programme.
- 8. Function indicators :**
To show the selected function.
- 9. Rinse Aid indicator**
To indicate when the dispenser needs to be refilled.
- 10. Main Display:**

	To show delay time, remain time, or error code.
	To show the degree of water consumption.
	To show the degree of energy consumption.
	To indicate the water faucet is closed.
	To indicate the child lock is on.
- 11. Programme indicators:**
To show the selected programme.

Quick Operation Guide

1 Preparation

- Confirm the utensils are suitable for cleaning by the dishwasher.
- Confirm the installation and the placement of the filter are correct.

2 Loading the dishwasher

- Scrape off any large amount of leftover food.
- Soften remnants of burnt food in pans, then load the basket.
- Follow to the loading instructions.

3 Adding detergent

- Use only dishwasher detergent. Read carefully and follow the instructions on the dishwasher detergent.

4 Washing and drying

1. Fully close the dishwasher door.
2. Turn on the dishwasher by pressing the OFF/ON button.
3. Press the Programme Selection button to select the programme as needed.
4. Press Start/Pause button to start the operation.

5 Operation completed

- Take out the items after 30 minutes from the completion of the operation. (When the operation is completed, the temperature inside the dishwasher is still very high and it is easy to get burnt.)
- Cleaning the filter.

Instructions for Use

Loading the Dishwasher

Placing items improperly may result in the door not being able to open and close, causing steam leakage, water leakage, and damage and deformation of the dishwasher and utensils, or affecting the cleaning result. Therefore, please observe the following instructions.

1. Items such as cups, glasses, pots and pans are faced downwards so that water cannot collect in the container or a deep base.
2. Curved items, or ones with recesses, should be loaded aslant so that water can run off.
3. All utensils are stacked securely and cannot tip over.
4. All utensils are placed in the way that the spray arms can rotate freely during washing.
5. Items of dishware and cutlery must not nest together, or cover over each other.
6. Do not overload the Dishwasher. This is important for good results and for reasonable consumption of energy.

Note:

- Very small items should not be washed in the Dishwasher as they could easily fall out of the basket.

■ Upper Basket

The Upper Basket is designed to hold more delicate and lighter dishware such as glasses, coffee and tea cups and saucers as well as plates, small bowls and shallow pans (as long as they are not too dirty).

Position the dishware and cookware so that they will not get moved by the spray of water.

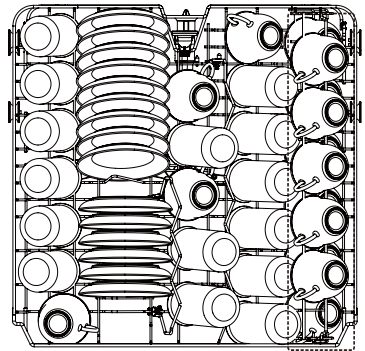

■ Lower Basket

Large items and items that are difficult to clean such as pots, pans, lids, serving dishware and bowls are placed into the Lower Basket. It is preferable to place serving dishware and lids on the side of the racks in order to avoid blocking the rotation of the Top Spray Arm.

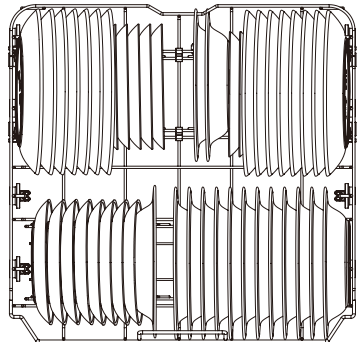

Instructions for Use

Loading the Dishwasher

■ Cutlery Rack

Long items, serving cutlery, salad servers and knives should be placed on the Cutlery Rack so that the utensils do not obstruct the rotation of the spray arms.

For optimum cleaning performance, place the cutlery in the Cutlery Rack. Make sure that:

- They do not nest together.
- Cutlery is placed either sideways or with the back or the spine facing upwards.

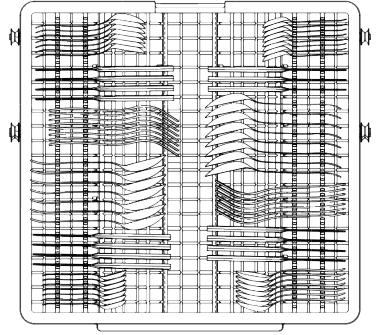

■ Adjusting the Upper Basket

The height of the Upper Basket can be adjusted in order to create more space for large utensils for the basket. The height of the Upper Basket can be adjusted as below shown.

To adjust to the upper position, hold both sides of the upper basket to lift it up to the upper rollers.

To adjust to the lower position, lift the adjust handles on each side to release the basket and lower it to the lower rollers.

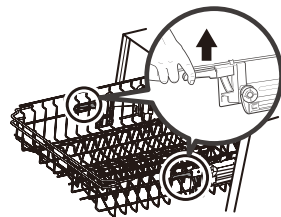
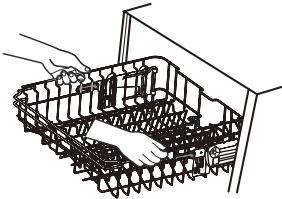

■ Folding Back the Cup Rack

For better stacking of pots and pans, the Cup Rack can be folded as shown in figure. You can also remove it when it is not required for use.

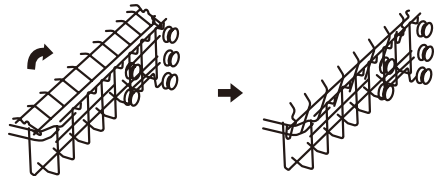

■ Folding Spikes of Lower Basket

The spikes of the lower basket are used for holding plates and a platter. They can be lowered to make more room for large items.

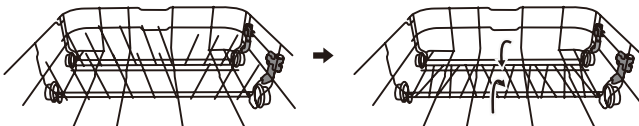

Instructions for Use

Adding Detergent

Use only dishwasher detergent.

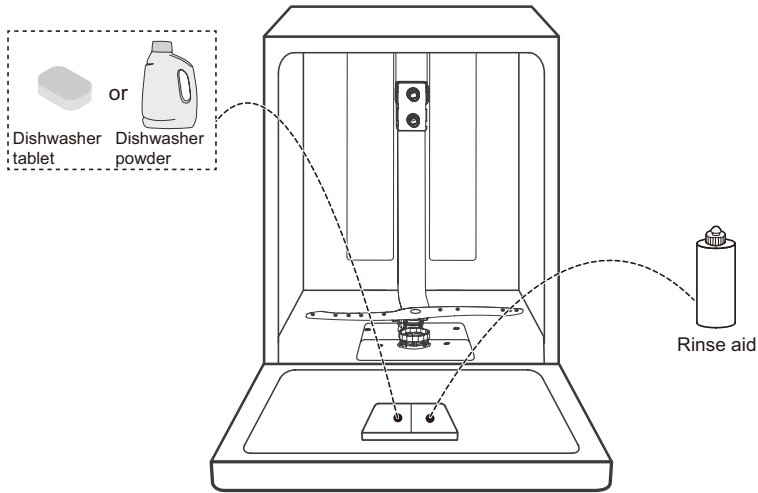

■ Adding the Dishwasher Powder (or Tablet)

1. Push the detergent compartment switch to the right, and the lid will open automatically.

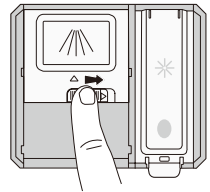

2. Add the recommended amount of detergent.

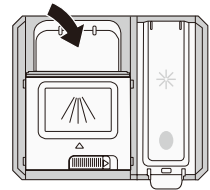

3. Push the compartment lid to close it until it locks in place.

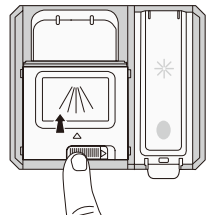

Note:

- Please read carefully and follow the precautions and instructions on the dishwasher detergent.

■ Function of the Rinse Aid

The rinse aid is released during the final rinse to prevent water from forming droplets on your dishes, which can leave spots and streaks. It also improves drying by allowing water to roll off the dishes. Your dishwasher is designed to use liquid rinse aids.

■ When Refilling the Rinse Aid Dispenser

The rinse aid indicator lights up indicating the rinse aid need to be refilled.

- The regularity of refilling the rinse aid dispenser depends on how often dishes are washed and the rinse aid setting.
- Do not overfill the rinse aid dispenser.

1. Press the rinse aid container lid buckle and lift the lid upward.

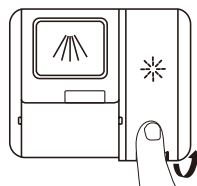

2. Fill the rinse aid container with rinse aid.

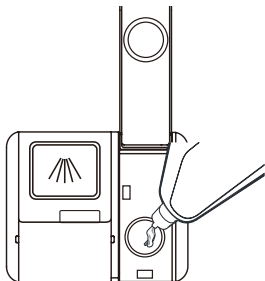

3. Close the lid back to place.



■ Adjusting the Rinse Aid Dispenser Setting

To achieve a better drying performance with limited rinse aid, the Dishwasher is designed to adjust the consumption by user. Follow the below steps.

1. Close the door, switch on the appliance.
2. Press the Programme ">" button for at least 5 seconds within 60 seconds from switching on the dishwasher. The Rinse Aid indicator blinks.
3. Press the Programme ">" button repeatedly to select the proper setting according to your using habits, the setting will change in the following sequence: d3->d4->d5->d6->d1->d2->d3. The higher the number, the more rinse aid the dishwasher uses.
4. Select the amount of the rinse aid and wait for 5 seconds or press the OFF/ON button to complete the setup and exit the setting mode.

Note:

- Increase the dose if there are drops of water or lime spots on the dishware after washing. Reduce it if there are sticky whitish stains on dishware or a bluish film on glassware or knife blades.







Instructions for Use

Starting a Programme

■ Wash Cycle Table

Note:

(●) indicates that the programme uses rinse aid in the last rinse.

Programme	Cycle information	Description of cycle	Detergent Pre/Main Wash	Running time(min)	Energy (kWh)	Water (L)	Rinse aid
ECO (*AS/NZS 2007.1)	This is the standard programme; it is suitable to clean moderately soiled dishware and is the most efficient programme in terms of its combined energy and water consumption for such dishwash.	Wash(50°C) Rinse Rinse(45°C) Drying	5/28.7g or all in 1	189	0.750	13.2	●
Auto 	For lightly, normally or heavily soiled crockery with or without dried-on food.	Pre-wash (45°C) Autowash (45°C-55°C) Rinse Rinse (65 °C) Drying	5/28.7g or all in 1	150	0.900-1.300	11.0-15.0	●
Intensive 	For heavily soiled items include pots and pans and moderately soiled dishware with dried-on food.	Pre-wash(50°C) Wash(70°C) Rinse Rinse Rinse(75°C) Drying	5/28.7g Or all in 1	151	1.758	19.0	●
Heavy 	For heavily soiled loads, such as pots, plates, glasses and lightly soiled pans.	Pre-wash(45°C) Wash(70°C) Rinse Rinse(75°C) Drying	5/28.7g Or all in 1	154	1.626	15.3	●
90 min 	Standard daily cycle for normally soiled loads such as pots, plates, glasses and moderately soiled pans.	Wash(65°C) Rinse Rinse(65°C) Drying	25g Or all in 1	90	1.270	11.6	●
Glass 	For lightly soiled crockery and glass.	Pre-wash Wash(42°C) Rinse Rinse(60°C) Drying	5/28.7g Or all in 1	125	0.860	13.1	●
Rapid 	A quick wash for lightly soiled loads that do not need drying.	Wash(40°C) Rinse Rinse(45°C)	25g	30	0.600	11.4	
Soak 	To rinse dishes that you plan to wash later that day.	Pre-wash	/	8	0.020	4.0	

Instructions for Use

Starting a Programme

Note:

- *AS/NZS 2007.1 : This program is the test cycle. The information for comparability test in accordance with AS/NZS 2007.1, as follows:
Capacity: 15 place settings
Position of the upper basket: lower position
Programme: ECO
Detergent(Pre/main): 5g / 28.7g
Rinse aid setting: 5
- The combination with the pre-wash detergent, and its quality of the effect may vary according to the detergent manufacturer. Consult the manufacturer upon purchase of the detergent.

■ Starting a Wash Cycle

1. Insert Power Plug to the mains socket. Switch on the main switch on the wall. Fully open the Dishwasher door.
2. Add the detergent in the dispenser.
3. Draw out the Lower Basket, Upper Basket and Cutlery Rack. Load the dishware to the baskets and push them back.
4. Fully close the Dishwasher door. Turn on the water supply.
5. Press OFF/ON button to switch on the Dishwasher.
6. Press Programme Selection button repeatedly until the desired programme icon lights up. The time needed to run the wash cycle will show on the Control Panel.
7. Press the Start/Pause button to start the washing.

■ Delay washing start time

1. Press the Time Delay button to select the desired delay time. Wash start time can be delayed from 1 hour to 24 hours.
2. Select desired programme by pressing the Programme Selection button until the selected programme icon lights up.
3. Press the Start/Pause button to start the time delay countdown. The washing programme will start automatically after the countdown is ended.

■ Changing the Programme

A cycle that is underway can be modified only if it has been running for a short time. Otherwise, the detergent may have already been released, and the Dishwasher may have already drained the wash water. In this case, the detergent dispenser must be refilled. To reset the programme, follow the instructions below:

1. Press the Start/Pause button then press the Programme ">" button for more than 3 seconds to cancel the running programme.
2. Select a new programme.
3. Restart the Dishwasher by pressing the Start/Pause button.

■ Adding Dishware during Operation

Dishware can be added at any time before the Detergent Dispenser opens.

1. Press the Start/Pause button to pause the Dishwasher.
2. Open the Dishwasher door and add the dishware.
3. Close the Dishwasher door. Then press the Start/Pause button. The Dishwasher will run after approximately 10 seconds.

■ At the End of the Wash Cycle

• Switch off the dishwasher

The Programme indicator turns off when the programme has ended.

1. Switch off the Dishwasher by pressing the OFF/ON button.
2. Turn off the water tap.
3. Switch off the main switch on the wall.

• Open the door carefully

1. Hot dishware is sensitive to breakage. The dishware should therefore be allowed to cool down for approximately 30 minutes before removing from the Dishwasher.
2. Slightly open the Dishwasher door and wait for approximately 30 minutes before removing the dishware. The dishware will be cooler and improve drying.

• Unloading the dishware

It is normal that the Dishwasher is wet inside. Empty the Lower Basket first and then the Upper Basket. This will avoid water dripping from the Upper Basket onto the dishwasher in the Lower Basket.

Cleaning and Maintenance

The filter prevents larger remnants of food or other objects from getting inside the pump. The residues that may block the filter must be removed.

■ Cleaning the Filter

1. Hold the coarse filter and rotate it in anti-clockwise direction to unlock the filter assembly. Lift the filter assembly upwards.

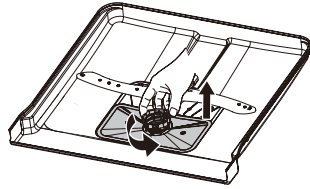

2. Disassemble the filter assembly.

Note:

- The Anti-bacterial filter works by releasing silver ions (Ag+) from the material inside the Ag+ unit to inhibit bacteria.
- The Ag+ material continuously releases silver ions for approximately 7 years, with no maintenance or replacement needed during this time.
- To order new Anti-bacterial filter, contact your distributor/dealer.

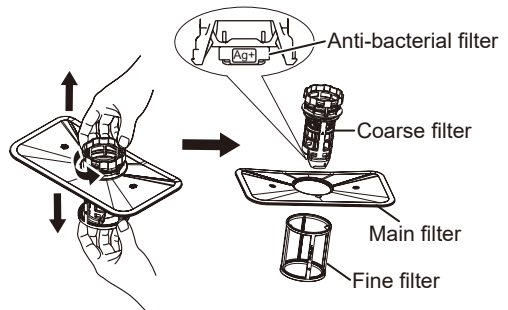

3. Clean the filter assembly. It is recommended to use a brush and clean under running water. Clean the groove under the filter at the bottom of the dishwasher to prevent food debris from clogging it.

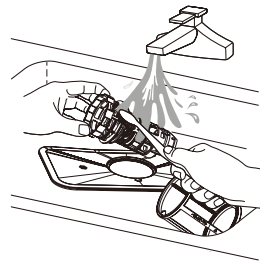

4. To replace the filter assembly to the dishwasher, reverse above steps. Rotate the Filter in clockwise direction until aligning the marks on the filter with those on the mesh.

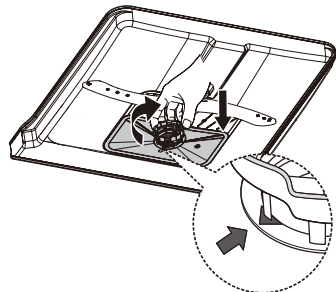

Note:

- When cleaning the Filter Assembly, do not knock or damage it, as the performance of the Dishwasher may decrease if the parts become distorted or broken.

Cleaning and Maintenance

■ Cleaning the Spray Arms

It is necessary to clean the spray arms regularly, chemicals from water will clog the spray arm jets and bearings. Wash the spray arms in soapy warm water and use a soft brush to clean the jets. Replace them after rinsing thoroughly.

To disassembly the spray arms:

- To remove the Upper Spray Arm, hold the nut and rotate the arm in anticlockwise direction.
- To remove the Lower Spray Arm, pull out the Lower Spray Arm in upward direction.

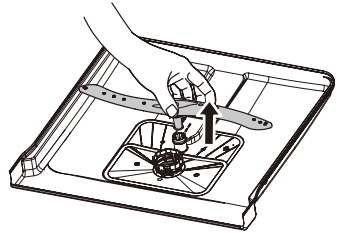
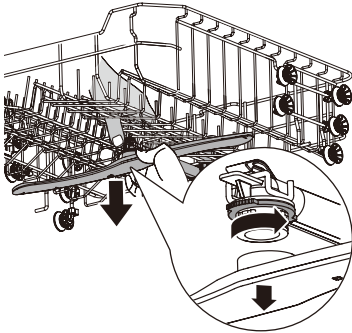

■ Caring for the Dishwasher

- The Control Panel can be cleaned by using a soft damp cloth. After cleaning, make sure to dry it thoroughly.
- For the exterior, use a good appliance polish wax. Never use sharp objects, scouring pads or harsh cleaners on any part of the Dishwasher. It will damage the Dishwasher.
- Wipe the door, vent and sealing with a damp soft cloth.
- Dirt is easy to accumulate at the edge sealing and vent of the dishwasher. Please clean carefully.
- Pull out the baskets and wipe off the dirt on the inside walls of the dishwasher.

Cleaning and Maintenance

■ How to Keep the Dishwasher in Good Condition

- **After every wash**

After every wash, turn off the water supply to the Dishwasher and leave the door slightly open so that moisture and odours are not trapped inside.

- **Remove the power plug**

Before cleaning or performing maintenance, always either switch off at the isolating switch or remove the Power Plug from the socket.

- **No solvents or abrasive cleaning**

a. To clean the exterior and rubber parts of the Dishwasher, do not use solvents or abrasive cleaning products. Only use a cloth with warm soapy water.

b. To remove spots or stains from the surface of the interior, use a cloth dampened with water and a little vinegar, or a cleaning product made specially for Dishwasher.

- **When not in use for a long time**

It is recommended to run a wash cycle with the Dishwasher empty and then either switch it off at the isolating switch or remove the Power Plug from the socket, turn off the water supply and leave the door of the Dishwasher slightly open. This will help the door seals to last longer and prevent odours from forming within the Dishwasher.

- **Moving the dishwasher**

If the Dishwasher needs to be moved, try to keep it in the vertical position. If necessary, it can be positioned slightly inclined on its back.

- **Seals**

One of the factors that cause unpleasant odours in the Dishwasher is the remains of food trapped in the seals. Cleaning the Dishwasher with a damp sponge periodically may prevent this.

Troubleshooting

	Problem	Possible Causes	What To Do
Technical problems	Dishwasher does not start	Fuse blown, or the circuit breaker may have tripped.	Replace fuse or reset circuit breaker. Remove any other appliances sharing the same circuit with the Dishwasher.
		Power supply is not turned ON.	Make sure the Dishwasher is turned ON and the door is closed securely. Make sure the power cord is properly plugged into the wall socket.
		Water pressure is low.	Check that the water supply is connected properly and the water is turned ON.
		Door of Dishwasher not properly closed.	Make sure to close the door properly and latch it.
	Water not pumped from Dishwasher	Twist in Drain Hose.	Check Drain Hose.
		Filter clogged.	Check the Coarse Filter. (See section titled "Cleaning the Filter").
Kitchen sink clogged.		Check the kitchen sink to make sure it is draining well. If the problem is the kitchen sink not draining, a plumber may be needed rather than a serviceman for Dishwashers.	
General problems	Suds in the tub	Improper detergent.	Use only the special Dishwasher detergent to avoid suds. If this occurs, open the Dishwasher and let suds evaporate. Add approx 4.5 litres of cold water to the tub. Close and latch the Dishwasher, then select any cycle. Dishwasher will drain out the water at the first step. Open the door after draining is stopped and check if the suds is disappeared. Repeat if necessary.
		Spilled rinse-aid.	Always wipe up rinse-aid spills immediately.
	Stained tub interior	Detergent with colourant was used.	Make sure that the detergent is the one without colourant.
	White film on inside surface	Minerals from water was formed.	To clean the interior, use a damp sponge with Dishwasher detergent and wear rubber gloves. Never use any other cleaner than Dishwasher detergent for the risk of foaming or suds.
	Water supply indicator light up	Water pressure is low.	Check that the water supply is connected properly and the water is turned ON. Check the inlet filter. If the inlet filter is clogged, clean it with a toothbrush in running water.
		Water supply being blocked by frozen water.	Wrap warm towels around the joints of the Inlet Hose. Disconnect the Inlet Hose, and soak them in warm water (50 °C or lower)
Noise	Knocking noise in the wash cabinet	A spray arm is knocking against an item in a basket.	Interrupt the programme, and rearrange the items which are obstructing the spray arm.
	Rattling noise in the wash cabinet	Items of crockery are loose in the wash cabinet.	Interrupt the programme, and rearrange the items of crockery.
	Noise in the Inlet Hose and Drain Hose	This may be caused by on-site installation or the cross-section of the piping.	This has no influence on the Dishwasher function. If in doubt, contact a suitably qualified plumber.

Troubleshooting

	Problem	Possible Causes	What To Do	
Unsatisfactory washing result	The dishes are not clean	The dishes were not loaded correctly.	See notes in "Loading the Dishwasher".	
		The programme was not powerful enough.	Select a more intensive programme. See "Wash Cycle Table".	
		Not enough detergent was dispensed.	Use more detergent, or change detergent.	
		Items are blocking the path of spray arms.	Rearrange the items so that the spray can rotate freely.	
		The Filter Assembly in the base of wash cabinet is not clean or is not correctly fitted. This may cause the spray arm jets to get blocked.	Clean and/or fit the filter combination correctly. Clean the spray arm jets. See "Cleaning the Spray Arms".	
	Cloudiness on glassware	Detergent is too much.	Use less detergent and select a shortest cycle to wash the glassware and to get them clean.	
	Black or grey marks on the dishware	Aluminium utensils have rubbed against the dishware.	Use a mild abrasive cleaner to eliminate those marks.	
Unsatisfactory drying result	Detergent left in dispenser	Dishes block Detergent Dispenser.	Re-load the dishes properly.	
		The dishes are not drying	Improper loading.	Load the Dishwasher as suggested in the directions.
			Too little rinse-aid.	Increase the amount of rinse-aid/refill the rinse-aid dispenser.
			Dishes are removed too soon.	Do not empty the Dishwasher immediately after washing. Open the door slightly so that the steam can escape. Begin unloading the Dishwasher only once the dishes have sufficiently cooled. Empty the low basket first. This prevents water from dropping from the dishes in the Upper Basket.
The dishes are not drying	Wrong programme has been selected.	In a short programme the washing temperature is lower. This also lowers cleaning performance. Choose a programme with a longer washing time.		
	Use of cutlery with a low-quality coating.	Water drainage is more difficult with these items. Cutlery or dishes of this type are not suitable for washing in the Dishwasher.		

Troubleshooting

■ Error Codes

If a malfunction occurs, the Dishwasher will display error codes as below:

Display Error Code	Definition	Possible Causes	Solution
E1	Longer inlet time.	Faucets is not opened, or water intake is restricted, or water pressure is too low.	Open the faucet / water supply or increase the water pressure of water supply.
E3	Heating Abnormal	Failure of heater	Contact a Panasonic Authorised Service Centre for assistance.
E4	Water overflow	Some Dishwasher components are leaking	Contact a Panasonic Authorised Service Centre for assistance.
E8	Failure of orientation of distributary valve.	Open circuit or failure of distributary valve	Contact a Panasonic Authorised Service Centre for assistance.
Ed	Failure of communication between main board and display board.	Open circuit or break wiring for the communication.	Contact a Panasonic Authorised Service Centre for assistance.



WARNING



To avoid danger to user and damage to the Dishwasher, repairs should only be performed by a suitably qualified serviceman.



- If overflow occurs, turn OFF the main water supply before contacting a Panasonic Authorised Service Centre.
- If there is water overflow or small leaks, the water should be drained before restarting the Dishwasher.

Specifications

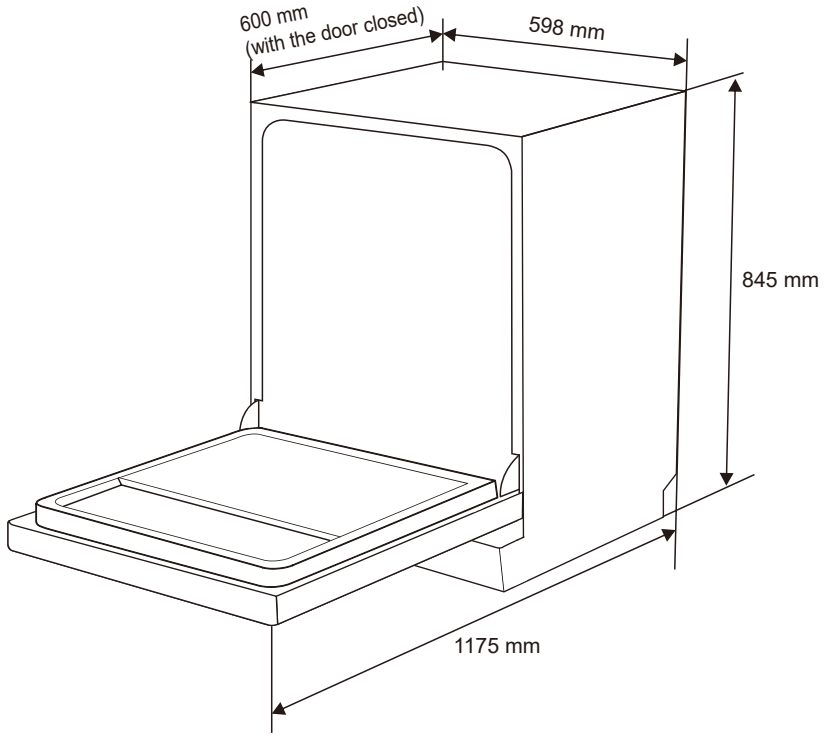

Model	NP-6X3MSQNZ NP-6V3MUQNZ
Power supply	220 - 240 V ~
Wattage	1760 - 2100 W
Frequency	50 Hz
Water pressure	0.04 - 1.0 MPa
Capacity	15 settings
Dimensions (L × W × H)	600 mm x 598 mm x 845 mm
Net weight	Approx. 41.5 kg

Specifications

Loading the baskets according to AS/NZS 2007.1:

Upper Basket

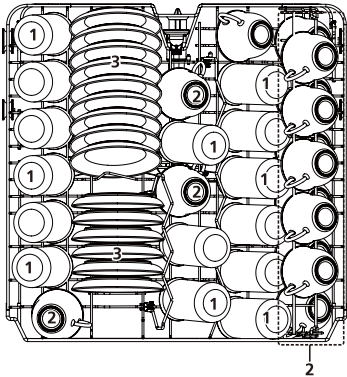

1. Glasses
2. Cups
3. Saucers

Lower Basket

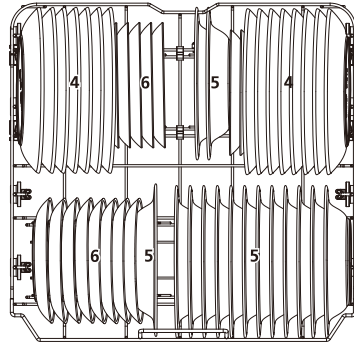

4. Dinner plates
5. Soup plates
6. Dessert dishes

Cutlery Rack

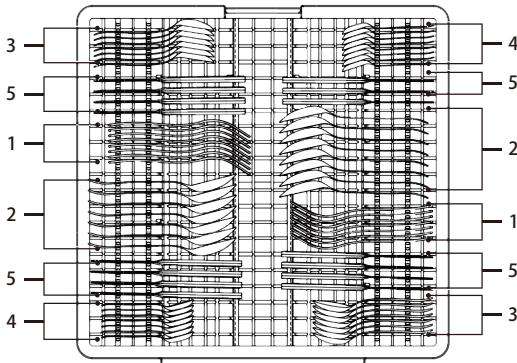

1. Forks
2. Soup spoons
3. Dessert spoons
4. Teaspoons
5. Knives

Information for comparability tests in accordance with AS/NZS 2007.1

- Capacity: 15 place settings
- Position of the upper basket: lower position
- Programme: ECO
- Detergent(Pre/main): 5g/28.7g
- Rinse aid setting: 5

Installation Instructions

For installer

■ Positioning the Dishwasher

Position the appliance in the desired location. The back should rest against the wall behind it, and the sides, along the adjacent cabinets or walls. The dishwasher is equipped with water supply and drain hoses that can be positioned either to the right or the left sides to facilitate proper installation.

- **Levelling the dishwasher**

Once the Dishwasher is positioned for levelling, the height of the Dishwasher may be altered via adjustment of the screwing level of the feet. The Dishwasher may be inclined by turning left direction and may be declined by turning right direction. In any case, the Dishwasher should not be inclined more than 2 °.

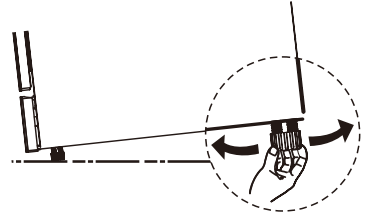

■ Electrical Requirements

Look at the Name Plate to know the rating voltage and connect the Dishwasher to the appropriate power supply. Provide a separate circuit serving only for this Dishwasher.

■ Electrical Connection

Ensure the voltage and frequency of the power correspond to those on the Name Plate. Only insert the Power Plug into an electrical socket which is earthed properly. If the electrical socket to which the Dishwasher must be connected is not appropriate for the Power Plug, replace the socket, rather than using adapters or the like as they could cause overheating and fire.

WARNING

 It is necessary to allow disconnection of this appliance from the mains supply after installation. This disconnection can be achieved by having the plug accessible or by incorporating a switch in the fixed wiring in accordance with the wiring rules.

 Ensure proper ground exists for earth wire before installation.

 Do not use an extension cord or an adapter plug with this Dishwasher.

 Do not cut or remove the earthing connection from the power cord under any circumstances.

IMPORTANT:

Correct installation is the responsibility of the installer. Any malfunction or accident resulting from the failure to follow the Installation Instructions is not covered by the warranty.

Installation Instructions

For installer

Water Supply Connection

IMPORTANT:

Preventing the risk of clogging or damage: if the water pipe is new or has not been used for a long time, before connecting to the water supply check that the water is clear and free of impurities, to prevent damage to the appliance. The dishwasher must always be connected to the water system with new hoses; old or used hoses must never be reused.

Inlet hose connection

Connect the Inlet Hose to a threaded 3/4 (inch) connector and make sure that it is fastened tightly in place. If the water pipes are new or have not been used for an extended period of time, let the water run to make sure that the water is clean. This precaution is needed to avoid the risk of the water inlet becoming blocked and damage the Dishwasher. Please fasten the nut lightly by hand and tighten it. The proper tightening torque is 5-10 N.m (50-100 kgf.cm).



Drain hose connection

Insert the dishwasher's drain hose into a drain pipe having a diameter of at least 40 mm (position A), or alternatively, place it inside the kitchen sink (position B), taking care not to crush or excessively bend the hose. It is important to fix the drain hose to prevent the hose from coming loose and falling.

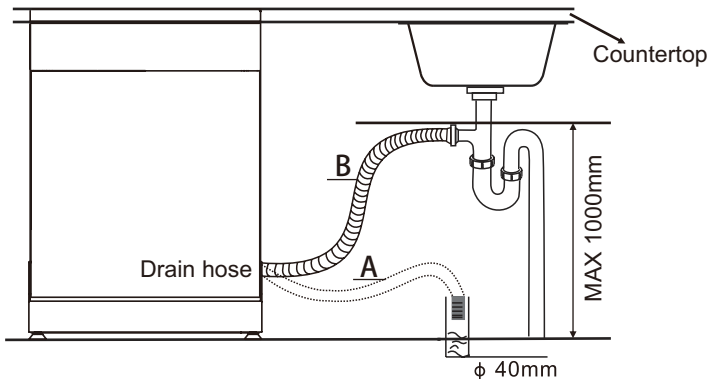

Note:

- The free end should be positioned at a height less than 1000mm, and should never be submerged in water.
- If a drain extension hose is needed, make sure to use a similar Drain Hose. It must not longer than 4 metres; otherwise the cleaning effect of the Dishwasher could be reduced.

Installation Instructions

For installer

■ Checkpoints After Installation

Following points should be checked before starting the Dishwasher.

1. The Dishwasher is level and fixed properly.
2. The inlet water supply is open.
3. Inlet Hose connections are fully tightened and not leaking.
4. The Power Plug is tightly connected.
5. The power is switched on.
6. The Inlet Hose and Drain Hose are knotted.
7. All packing materials and printings should be taken out from the Dishwasher.

Panasonic Corporation

Website: <http://www.panasonic.com>

Printed in China

© **Panasonic Corporation 2025**

v1.0