

➤ Encendido / apagado 

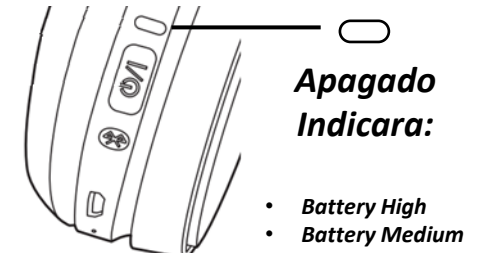
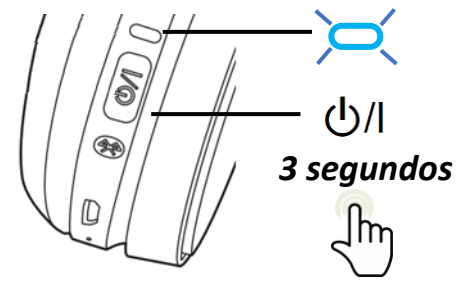
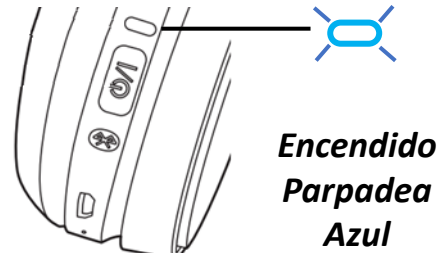
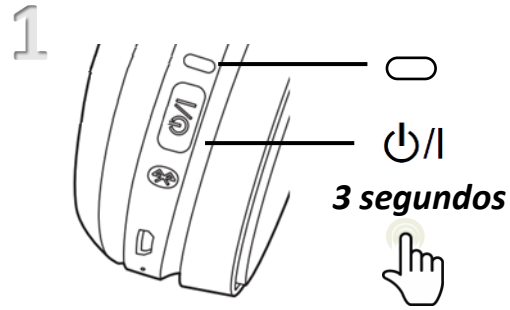

➤ Carga

2

Nota:

-El LED se ilumina en rojo cuando la carga esta en curso

El tiempo de carga desde descargado a 100% dura aproximadamente 2.5 horas

Si el LED no enciende al conectarlo a USB, el Audifono esta cargado al 100%

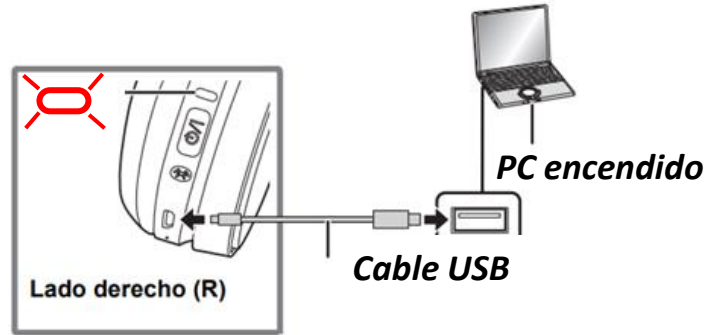

Al Completar la carga el LED se apagará aun conectado a USB

Carga 100%

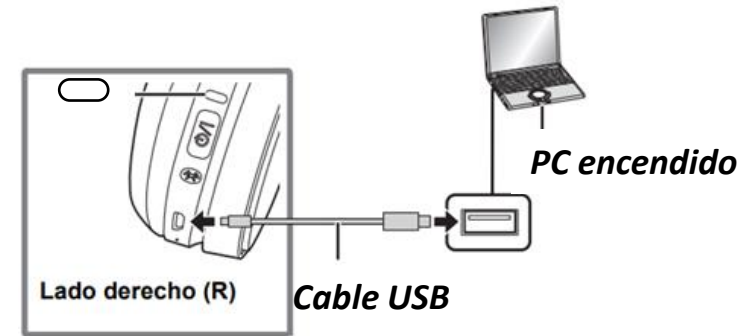

➤ Conexión a Bluetooth 

3

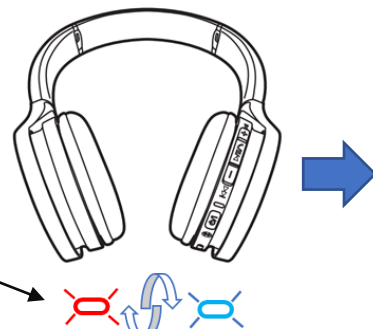
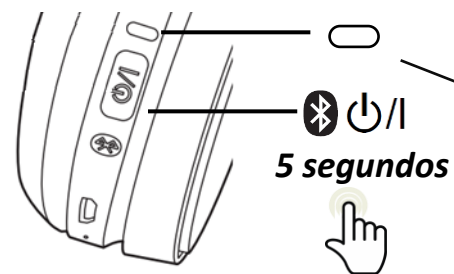

El LED parpadea en rojo y azul hasta completar la conexión con el dispositivo

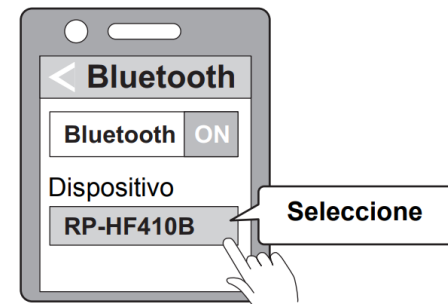

Contraseña: 0000



Indicará:
Bluetooth is connected



Cuando el LED parpadea en color azul, la conexión se ha establecido.

➤ **Control y reproducción**

4

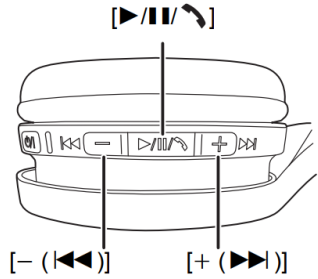

Nota: Se recomienda presionar los botones con una fuerza menor a 6 kg para extender su vida útil.

Función	Operación
Reproducir / Pausa	Pulse [▶/⏸/⏪].
Aumentar el volumen	Pulse [+ (▶▶)].
Reducir el volumen	Pulse [- (◀◀)].
Avanzar al inicio de la siguiente pista	Mantenga pulsado [+ (▶▶)].
Volver al inicio de la pista actual	Mantenga pulsado [- (◀◀)].

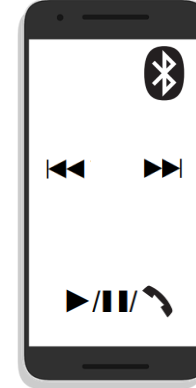

➤ **Responder Llamadas**

5

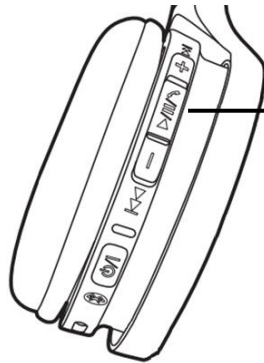

[▶/⏸/⏪]
Contestar

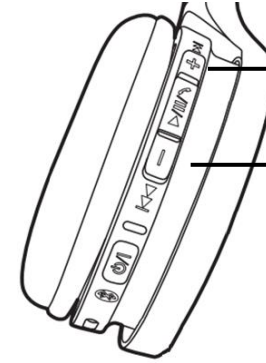

+
-
Ajustar Volumen

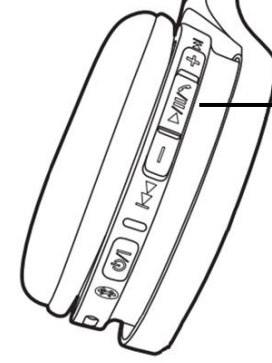

[▶/⏸/⏪]
Colgar

➤ **Restauración Ajustes de Fabrica**

6

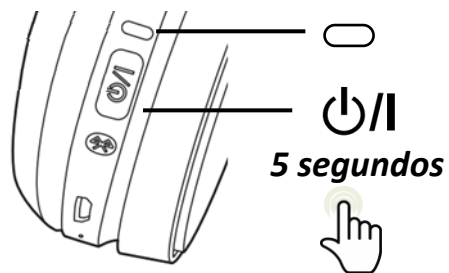

5 segundos



[+ (▶▶)] y [- (◀◀)]
Ambos botones
5 segundos

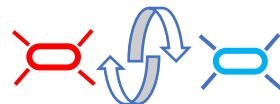

Parpadeo rápido

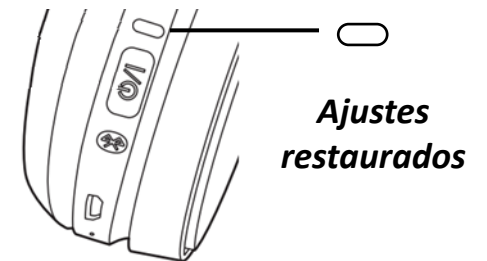

Ajustes restaurados