

Troubleshooting (Before calling for service)

Check the following conditions before calling for repair or service. If malfunction and issues continues, please contact Panasonic Customer Care Center.

The refrigerator does not operate.

- Check that the plug and its socket are in good condition.
- Check if there is any problem on main fuse and electrical system of the house.
- Check by unplugging, wait for 10 minutes before plugging it back in.

The refrigerator does not cool enough.

- Check if the temperature control dial is at the proper position.
- Check to see if the refrigerator is overloaded with stuff or there is any hot foodstuff refrigerated inside.
- Is the refrigerator exposed directly to sunlight or heat source?
- Is the refrigerator door completely closed?
- Is the refrigerator door opened frequently?

Vapor generated inside and outside the cabinet / surface of door.

- Condensation may appear on the surface of cabinet when humidity is high, e.g. during rainy season or the air circulation is not good.
- If there is condensation inside, check if the door is completely closed.
- Is the refrigerator frequently opened or left open for a long time?
- Is there any hot foodstuff refrigerated inside?

The refrigerator generates noise.

- Check if the refrigerator is located on stable floor or installed properly.
- Check if there is any object in contact with the refrigerator.
- If the refrigerator is set correctly, noise may come from the inverter used to control the compressor rotation speed. This sound is almost always present and it is normal.
- The normal operation of the refrigerator will cause some sound that are normal. Please feel at ease to use it.



Lamp does not turn on.

- Please contact Panasonic Customer Care Center.

Specifications

Model No.		NR-AQ211VS
Capacity (L) Gross / Storage (ISO 15502)	Total	217 / 198
	Freezer	27
	Refrigerator	170
Net Weight (kg)		40
Outside Dimensions Width x Depth x Height (mm)		540 x 620 x 1216
Refrigerant Type		R600a
Rated Voltage (V), Rated Frequency (Hz)		230 V~, 60 Hz
Cooling System		Direct Cooling
Defrosting System		Manual with Defrost Button
Color		Ceramic Gray

Panasonic Manufacturing Philippines Corporation
Website: <http://panasonic.com/ph>

© Panasonic Manufacturing Philippines Corporation 2020



NR-AQ211VS

Panasonic®

Operating Instructions 1-Door Refrigerator

(For Household Use)

Model No. NR-AQ211VS



Special Features

- Direct Cool Inverter Technology
- Intelligent Econavi Sensors
- High Efficiency and Low Noise Compressor
- Ceramic Matte Finish, Flat Panel Door Design
- Fire-retardant Power Plug Design
- Built-in Deodorizer
- Side Mounted LED Lighting
- Electronic Temperature Control
- High Strain and Scratch-Resistant Inner Wall
- PCM Cabinet with Embossed Detail
- Movable Ice Tray
- Convenient Defrosting (Defrost Button)
- Efficient Cooling
- Hot Pipe Moisture Eliminator
- Built-in Leg Adjuster
- RoHS Compliant Product
(Restrictions on Hazardous Substances)
These are regulations that set maximum concentration limits on hazardous substances in materials used in electrical and electronic equipment.
- Environment Friendly
Non-CFC Materials both refrigerant (R600a) and for insulation (Cyclopentane). This Refrigerator does not damage the earth's ozone layer.

Contents

Safety Precautions	2
Installation	4
Parts Identification	5
General Operation	6
Usage Tips	7
Storage Tips	8
Energy Saving Tips	9
Proper Maintenance	9-11
Troubleshooting	Back Page
Specifications	Back Page

Thank You
for buying Panasonic
Refrigerator

Before operating this product, please read the instructions carefully and save this manual and the warranty certificate for future use.



G0120MB0
AK-179430
Printed in the Philippines

Safety Precautions

The following explanations are provided to prevent personal injuries and property damages to the users and other people.

⚠️ WARNING

This sign warns of risk of death or serious injury.

⚠️ CAUTION

This sign warns of injury or damage to property.

⚠️ This symbol means required actions.

⊘ This symbol means prohibited actions.

⚠️ This symbol means do not disassemble.

⚠️ WARNING

This appliance is not intended for use by persons (including children) with reduced physical, sensory or mental capabilities, or lack of experience and knowledge, unless they have been given supervision or instruction concerning use of the appliance by a person responsible for their safety.

Children should be supervised to ensure that they do not play with the appliance.

For plug and cord..

- ⚠️ Unplug the unit when cleaning the refrigerator.
- ⚠️ Properly plug the unit into a wall outlet with its required voltage.
- Connect the unit to an exclusive wall outlet that is for the refrigerator only. Avoid connecting other appliances to the same wall outlet.
- Periodically wipe the dust on the power plug.
- If the power supply cord is damaged, it must be replaced by the manufacturer, its authorized service centers, or similarly qualified persons in order to avoid hazard.
- If you detect burning smell, unplug the unit and ventilate the area.
- Please ensure minimum clearance of 10 cm for air ventilation and to prevent damage to the power supply cord.
- When abnormality and failure occurs, stop using the product immediately and unplug the unit. Abnormality and failure example: (Risk of smoke/ fire/ electric shock)
 - Power cord or plug is abnormally hot
 - Power cord is deeply cut or deformed
 - There is burning smell
 - You can feel tingling electricity

Note: Please contact the Panasonic Customer Care Center for maintenance and repair.

In case of emergency..



- Risk of Fire / Flammable Materials
- Maintenance work must only be carried out by well-trained maintenance worker.
- ⊘ Do not store explosive substances such as aerosol cans with a flammable propellant and chemicals or scientific specimens in the appliance.
- Do not use electrical appliances such as Ion deodorizer/ Humidifier in the refrigerator. Leaked refrigerant may catch fire from a spark of the electrical contacts and may cause an explosion.
- Do not use electrical appliances inside the food storage compartments of the appliance, unless they are the type recommended by manufacturer.
- ⚠️ Do not disassemble, repair or modify the refrigerator by yourself. If you want to repair the refrigerator, please consult Panasonic Customer Care Center.
- Do not use mechanical devices or other means to accelerate the defrosting process, over than those recommended by the manufacturer.

For connection..

- ⚠️ Plug your refrigerator into a wall outlet of 230 V~, 10 A or more, exclusively.
- ⊘ Do not plug your refrigerator to an octopus connection.
- ⊘ Do not plug your refrigerator to an extension cord.
- ⚠️ Do not plug your refrigerator to any loose outlet. Power cord may deteriorate and may cause fire.

When recycling the product..

- ⚠️ Before taking the refrigerator to be recycled, please remove all the door gasket to prevent locking a child inside it.
- The operating instructions should be handed over to any person who would use or handle the refrigerator whenever the refrigerator would be transferred to another location and delivered to a recycling plant.
- Cyclo-Pentane is used for insulation of this refrigerator and flammable gas is used for the refrigerant. When disposing off this unit, please dispose it by the proper method, do not burn the unit.

Proper Maintenance (Accessories)

Crisper Case

Crisper Case

Clean regularly to remove food residues and accumulated dirt.

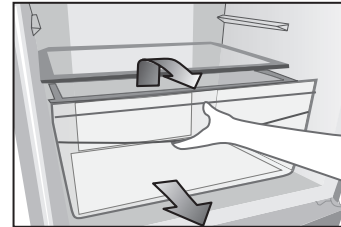

Removing

Pull out the case gently until it comes out of the compartment. Slightly lift the front portion to remove it completely.

Attaching

Insert the case gently into the slot and until it reaches the end of the compartment.

Crisper Glass

Crisper Glass

To remove, lift the front portion of the glass and carefully pull it outward.

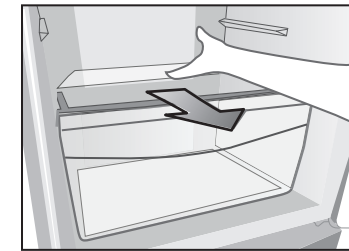
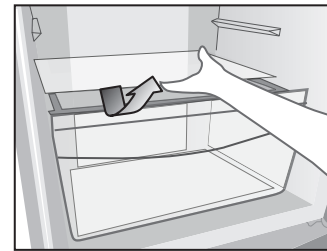

Caution

Note: Please handle with care so that it does not fall and cause any damage or injury.

Defrost Pan

Defrost Pan

Must be cleaned regularly to remove accumulated water and dirt.

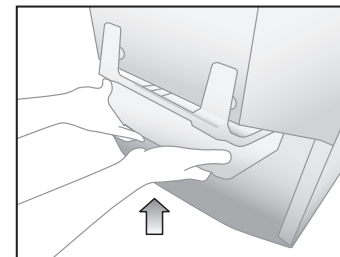

Removing

Lift the defrost pan upward to release it from the hook.

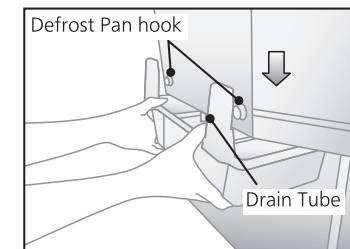

Attaching

Insert the hooks to the defrost pan and push it downward until it locks.

Note: Make sure to attach it gently you might hit the drain tube upon attaching the defrost pan.

Proper Maintenance (Accessories)

Door Shelves

Clean the door shelves occasionally, wash them with lukewarm water every three (3) months to remove accumulated dirt.

Free Shelf and Egg Shelf

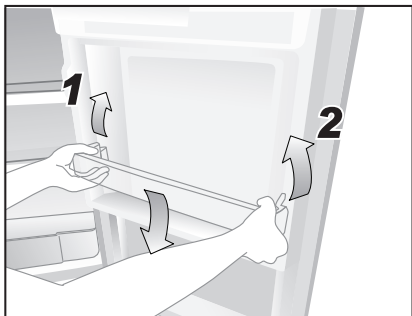

Removing

1. Gently lift the left side of the shelf to release the hook.
2. Once the shelf is released, lift it up to remove it completely.

Attaching

Place the right side of the shelf to the hook and gently push the other side downwards to fix it in place.

Bottle Shelf

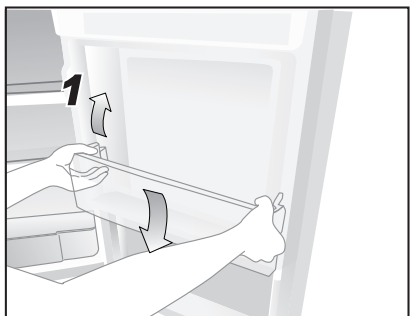

Removing

1. Gently lift up the Bottle Shelf to remove it completely.

Attaching

Gently push down the shelf to fix it in place.

Wire Shelves

Wire Shelves

Wire shelves must be cleaned regularly to remove food residues and accumulated dirt.

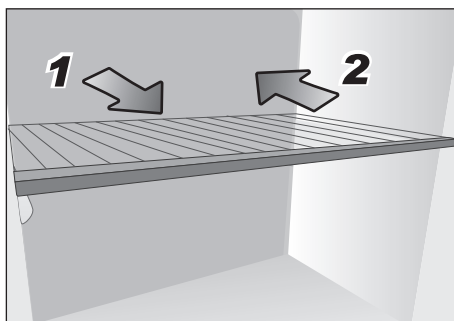

Removing

1. Carefully pull the tray out of the compartment.

Attaching

2. Push the tray until it reaches the end of the supporting rail.

When installing the refrigerator..

- Do not install the product in locations exposed to water.
- Leaked refrigerant may cause fire and explosion.

When using..

- Do not let any children hang or ride on the refrigerator door, the unit may turn over and cause an accident.
- Do not damage the refrigerant circuit (piping on the back). The flammable refrigerant may catch fire and lead to an explosion.
- Do not touch the compressor or pipes because of high temperature. There is a risk of burn injury.

- Do not spray combustible chemicals near the refrigerator.

- If you detect a burning smell, disconnect the power plug to stop the operation of the unit.
- If you detect a gas leak from the cooling circuit, ventilate the kitchen.
- If you damaged the cooling circuit (piping at the back), ventilate the kitchen and contact your nearest Panasonic Authorized Service Center.
- Refrigerator LED Lamp. The refrigerator LED lamp is designed specially for this product, it does not function on individual replacing. If replacement is required, contact the Panasonic Care Center Hotline.

CAUTION

When moving or transporting the refrigerator..

- Do not transport the refrigerator in a horizontal position. Laying the refrigerator horizontally may damage the piping. If any damage is noticed, do not operate the refrigerator, avoid using fire and ventilate the room.
- Make sure that the door is facing up to avoid accidental opening of doors when lifting.
- It is recommended to lift it or use rag underneath the unit to avoid it from scratching the floor.

- Do not subject glass tray to high impact. (glass trays may break and cause injury.)
- Food containers must reach the bottom of the door shelves.
- Food must not protrude from the shelf.
- Store fruits and vegetables inside the Crisper case.
- Trapped moisture helps to preserve the freshness of food for longer period.
- Drinking water, and other beverage should be sealed to prevent odor contamination.
- Vegetables, fruits and fresh food should be wrapped or packed in a container before freezing or refrigerating.
- Put the food such as meat or fish in the freezer compartment if you want to store for a long time.
- Cover juicy food with tight lid containers, plastic film or foil.

If you will not use the refrigerator for a long period of time..

- Unplug the refrigerator and take out all the food in the refrigerator and freezer compartment.
- Wipe off all the water and open the refrigerator to keep it dry.
- Prevent children from entering the refrigerator.

When cleaning..

- Do not clean the refrigerator with chemical substance or liquid. It will cause damage and corrosion on the metal surface.
- Do not place your hands or feet beneath the refrigerator.
- Clean the defrost pan located at the back of the unit every three (3) months to prevent the odor generated from the defrost pan.

When opening or closing the doors..

- Do not place items that are bigger than the tray or shelf, the door will not close completely causing hot air to enter the refrigerator.
- Do not open the refrigerator frequently or leaving it open for a long time to prevent water dripping inside and waste energy.
- Mind the gap between the door seal (Gasket). It must be completely closed to the cabinet body.

Caution..

- If the crisper glass accidentally breaks, please observe necessary precautions to avoid injuries.
- If the unit does not run, unplug the unit to reset the PCB program.
- Wait for at least ten (10) minutes before replugging to continue its operation.

When storing food..

- Do not freeze glass bottles, that there are risk of injury. (If liquid in a glass bottle is frozen, the bottle will break and may cause injury.)
- Do not overload the refrigerator. Maintain proper spacing for good air circulation.
- Do not place warm/hot food inside the refrigerator. Allow hot food to cool down before placing inside the refrigerator.
- Do not operate without the defrost pan.
- Avoid direct water contact on areas near the Temperature control box, to protect you from accidental electric shock.

For maintenance and service..

Panasonic Customer Care Center:

Text us: Globe: Panasonic <space> message send to 2327
Non-Globe: Panasonic <space> message send to 0917-890-2327

Contact Number: (02) 8706-7603; **Fax:** (02) 8706-7612

Email: pmopc_csdic@ph.panasonic.com

Website: <http://www.panasonic.com/ph>

Installation

The distance between the wall and the unit

- Allow a space of at least 15 cm at the top portion, 17 cm on the back side, 10 cm on the left side, and 25 cm on the right side when installing the unit.

To dissipate the heat emitted by the unit. Allowing enough space for door opening and removal of accessories.

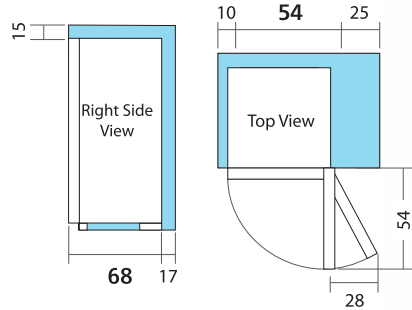

(Refrigerator dimensions for installation)



Remove the Bottom box, Tapes, and Styrofoams

- Do not install the Refrigerator with the bottom box.
- Remove the bottom box to prevent serious damage to the unit.
- Make sure to remove all tapes and styrofoams attached inside and outside of the Refrigerator.

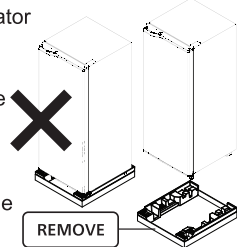

Before installation remove the Shock Absorbers

- Shock absorbers are attached to the Defrost Pan to hold and support the compressor during transport.

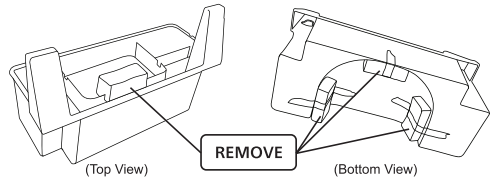

Check the instruction label at the back of the unit for removal process.

Leveling the refrigerator

- Turn the adjustable leg shell clockwise until it reaches the floor to stabilize and level the unit to the ground.

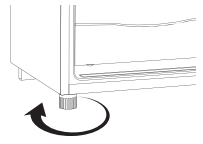

For Safety, grounding connection should be done.

The grounding connection will allow prevention of danger resulted from electricity leakage.

- This appliance must be properly earthed to prevent electric shock. Grounding terminal is provided at the back of the refrigerator.

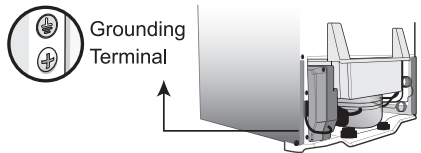

Area around where the refrigerator is installed

- Place the unit on sturdy and flat floor.
- Do not place your refrigerator near any source of moisture like faucets and sinks.
- Do not place your refrigerator in a humid place as rust may form and may cause electric shock.
- Do not place your refrigerator near any source of heat like gas range, gas stove, and direct sunlight to avoid weak performance of the unit.
- Do not block door openings under any conditions.
- The refrigerator must be located in the place where there is a good air circulation.
- In case of placing the refrigerator on an uneven surface, adjust the built-in adjustable leg shell to make the unit stable.

Moving or shifting

- When moving or shifting the refrigerator, remove the accessories inside and make sure there is no water inside the unit.

Energy Saving Tips

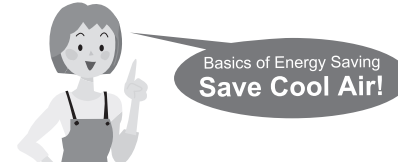

Do not store hot food items inside, be sure to cool them down.

- Otherwise they will not only raise the interior temperature, it can also affect the freshness of the food inside the refrigerator.



Do not keep the refrigerator door open for a long period of time.

- Minimizing the number of times that the door is open preventing hot air from entering and reduces the amount of wasted Electricity.

Adjust the Temperature Setting based on corresponding load.

- To avoid excessive ice formation and to conserve electricity.

When condensation occurs.

- The humidity in the vegetable case is high and condensation may occur, just wipe off the water drops.

Do not store food when it is not necessary.

- If uncut tropical fruits are cooled down excessively, It may be discolored / vitamin content may decrease.
- It is not necessary to store uncut onions, potatoes, etc. in the refrigerator (except during summer).



Just cool before you eat!



A cold dark place will do.



Storage using hermetically sealed containers is recommended!

To prevent the interior from being discolored!

- Cut citrus fruits (→ The plastic will be discolored white.)

To prevent odors from spreading!

- Garlicky or other strong smelling vegetables (→ Odors will spread to other nearby food.)

Proper Maintenance

Cleaning, Removing and Re-installing

Before cleaning or conducting maintenance, be absolutely sure to disconnect the power plug from the outlet. Do not connect or disconnect the power plug with wet hands.

When disconnected, leave it for 10 minutes before plugging. If not, the compressor may not work.

Interior Cleaning

Wipe off the stain with warm water. When stains cannot be removed easily, wipe it gently using soft cloth with soap and warm water, then wipe the soap off using damp soft cloth.

Exterior Cleaning

Cleaning by using soft cloth with warm water and soap. Then wipe off the soap.

Clean the Door Gasket at least Once a month.

This area was applied with wax to reduce friction on the refrigerator body. Be careful not to wipe it off. Clean by wiping softly.

If the gasket comes off the grip, push it back. The door gasket is replaceable.

Dirty gasket can limit the contact on the cabinet leading cold air to escape the compartment.



Note: Do not use the following items. (otherwise the surface will be scratched.)



Storage Tips

Food Storage

- In order to preserve freshness of food for a long period of time, please store it in the right place.

Freezer Compartment

Storing food for extended period of time. For storage of frozen and dried food.



Refrigerator Compartment

For regular storage of food and drinks or any food for temporary storage.



Crisper Case

A rather high humidity that keep fruits and vegetables fresh and juicy.



- When set to "MID", the temperature may vary slightly depending in the usage and storage conditions.



Provide a sufficient space when storing food items inside the Refrigerator Compartment for good temperature result.



Foul smelling food must be wrapped or covered before placing inside the unit to prevent bad odor.



Do not store bottled and canned drinks in the Freezer Compartment to avoid bursting of liquid content due to low temperature

Usage

- Do not use any sharp objects (knife, fork) when removing ice formation or food residue in the Freezer Compartment to avoid puncturing the inner liner and evaporator.

- Place the Wire Shelves in the proper slots, do not put them in the small slot under the Temp. Control Box. The slot is not designed to carry any load and it can damage the Temp. Control Box or the Inner Liner.



- This refrigerator is equipped with a "Hot Pipe Moisture Eliminator" located on the front and side portion of the cabinet to prevent moisture from accumulating on the surface of the cabinet. it is normal that it feels warm when touched.



Parts Identification

FREEZER COMPARTMENT

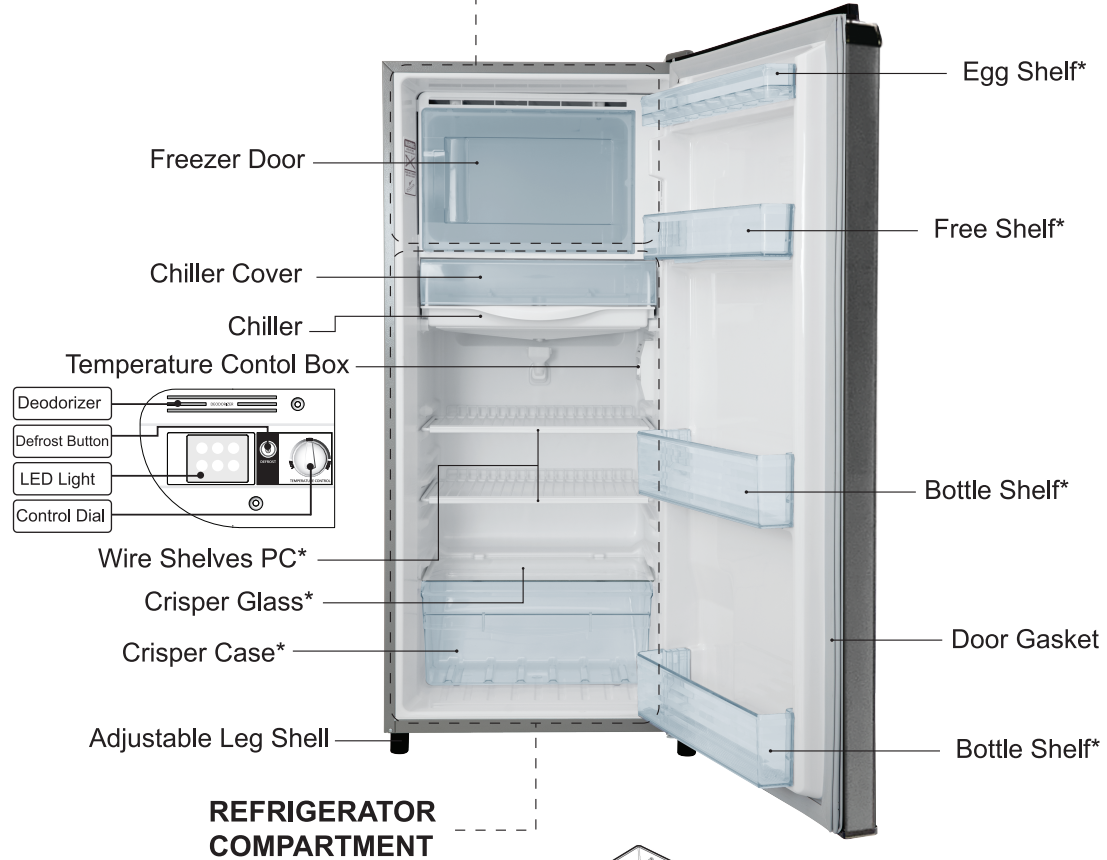

REFRIGERATOR COMPARTMENT

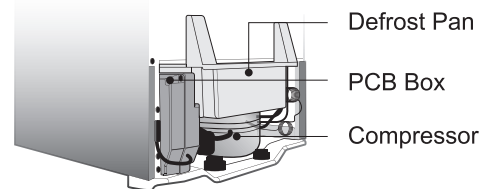

(Product view from behind)



Accessories: (*)	
• Ice Scraper	• Egg Shelf
• Ice Tray	• Free Shelf
• Wire Shelf PC (2 pcs.)	• Bottle Shelf (2 pcs.)
• Crisper Glass	• Crisper Case

General Operation

- Upon delivery, allow a stabilization period of 3-5 hours to allow compressor oil to settle down.
- Plug the power supply cord into a wall outlet of 230 V 10 A or more, exclusively, and set the Temperature Control Dial to "High".
- Set to desired setting after 2 hours before loading the food.

Temperature Control Setting

Note: The Temperature Control Dial can be adjusted to achieve your individual requirements.

Load/Condition	For storing minimal amount of food (This setting is enough to preserve food and keep beverages cool)	For storing moderate amount of food	For storing large amount of food and faster freezing
Recommended Dial Setting			

Note: Temperature of the refrigerator compartment can vary depending on the environment, room temperature and the amount of food stored in the refrigerator.

Special Features

Inverter Technology

In accordance with temperature change inside the compartment, the motor will run at different speeds. When the temperature inside the refrigerator is stable, the motor will run at a lower speed to save energy and lower noise.

INVERTER

When powerful cooling is required, the motor will run at a higher speed.

ECONAVI Sensors

This refrigerator is equipped with sensors that detects the condition of use.

ECONAVI

Econavi sensors learns the lifestyle patterns of your family from door opening and time of infrequent use to maximize energy efficiency.

ECONAVI Operation

This refrigerator is equipped with ECONAVI sensors that detects condition of use.

Internal Temperature Sensor and Door Switch Sensor learns the usage pattern of your family from door opening and time periods of infrequent use to minimize energy efficiency.

ECONAVI operates only when the temperature setting is set to "MID".

■ ECONAVI operation

- The refrigerator learns the lifestyle patterns of your family from door opening and time period of infrequent use to maximize energy efficiency.
- ECONAVI operation is automatically enabled when temperature control for refrigerator compartment is set to "MID".

Remarks:

The effectiveness of the ECONAVI mode is dependent on the ambient temperature and the number of times the refrigerator door is opened and closed and the state in which food is stored.

Usage Tips

Freezer Compartment



Three tips for freezing food and locking in the flavour...

- Freeze thin and small items of food quickly!
- Container must be fully sealed.
- Do not refreeze.

To make ice

1 Take out the Ice Tray

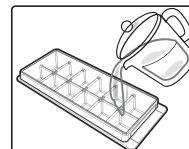

Fill up the tray with water.

2 To remove the ice cubes

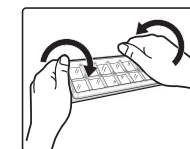

Hold both ends of the ice tray and twist each end in opposite directions.

Defrosting and Cleaning

When to Defrost

Defrosting is necessary when the ice formation reaches the thickness of 10mm.

Note: Excessive ice formation on the freezer compartment reduces your unit's cooling efficiency.

10 mm frost →



How to Defrost

- Push the Defrost Button, turn the thermostat dial to "Mid" position or unplug the unit.

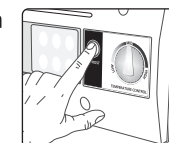

- Remove all contents and accessories of the refrigerator, and clean the inner walls using a damp soft cloth.

(See the cleaning instructions on p.9 - p.11)

- Leave the refrigerator and freezer door open to accelerate the defrosting time. (Optional)

(You can also use the ice scraper provided to remove large amount of ice formation)

- When the ice/frost has melted, press and hold the defrost button for 3 seconds and the system will automatically turns on to resume cooling operation.

(Blinking of the LED lights will stop once cooling operation resumes.)

Note:

- After defrosting, normal cooling operation will resume after 10 minutes.
- Blinking LED lights indicates that the unit is in defrost mode. The LED lights will not blink under normal cooling operation.
- When in defrost mode the system turns off the compressor so you don't have to unplug the unit.

- Defrost water will flow into the defrost pan located behind the unit; water will evaporate during normal cooling operation.

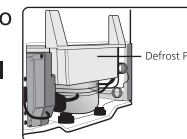

- It does not have a defrost heater or any mechanism that can speed up defrosting.