

Panasonic[®]

Operating Instructions

Digital Cordless Phone

Model No. **KX-TGU410CX**



Before initial use, see "Getting Started" on page 10.

Thank you for purchasing a Panasonic product.

Please read these operating instructions before using the unit and save them for future reference.

Table of Contents

Introduction

Accessory information	3
Graphical symbols for use on equipment and their descriptions	4

Important Information

For your safety	5
Important safety instructions	7
For best performance	7
Other information	8
Specifications	8

Getting Started

Setting up	10
Controls	12
Display icons/Indicators	13
Turning the power on/off	15
Date and time	15
Other settings	15

Making/Answering Calls

Making calls	17
Answering calls	18
Useful features during a call	18
Key lock	20

Nuisance Call Block

Nuisance call block	22
Storing unwanted callers	22

Automated Call Block

Automated call block	25
----------------------------	----

Phonebook

Phonebook	28
Speed dial	29
Favourites Key	30

Programming

Menu list	32
Alarm	38
Do not disturb mode	38
Baby monitor	39
Other programming	41

Caller ID Service

Using Caller ID service	44
Caller list	45

Useful Information

Voicemail service	46
Character entry	46
Error messages	48
Troubleshooting	49
Registering a unit	54

Index

Index.....	56
------------	----

Accessory information

Supplied accessories

No.	Accessory item/Part number	Quantity
①	AC adaptor/PNLV226CE0R	1
②	Telephone line cord	1
③	Rechargeable batteries*1	2
④	Handset cover*2	1

*1 See page 3 for replacement battery information.

*2 The handset cover comes attached to the handset.



Additional/replacement accessories













Please contact your nearest Panasonic dealer for sales information.

Accessory item	Model number/Specifications
Rechargeable batteries	Battery type: – Nickel metal hydride (Ni-MH) – 2 x AAA (R03) size for the handset – 1.2 V

Other information

- Design and specifications are subject to change without notice.
- The illustrations in these instructions may vary slightly from the actual product.

Graphical symbols for use on equipment and their descriptions

Symbol	Explanation	Symbol	Explanation
	Alternating current (A.C.)		Class II equipment (equipment in which protection against electric shock relies on Double Insulation or Reinforced Insulation)
	Direct current (D.C.)		"ON" (power)
	Protective earth		"OFF" (power)
	Protective bonding earth		Stand-by (power)
	Caution, risk caused by visible radiation		"ON"/"OFF" (power; push-push)
	For indoor use only		Caution, risk of electric shock

For your safety

To prevent severe injury and loss of life/property, read this section carefully before using the product to ensure proper and safe operation of your product.

WARNING

Power connection

- Use only the power source marked on the product.
- Do not overload power outlets and extension cords. This can result in the risk of fire or electric shock.
- Completely insert the AC adaptor/power plug into the power outlet. Failure to do so may cause electric shock and/or excessive heat resulting in a fire.
- Regularly remove any dust, etc. from the AC adaptor/power plug by pulling it from the power outlet, then wiping with a dry cloth. Accumulated dust may cause an insulation defect from moisture, etc. resulting in a fire.
- Unplug the product from power outlets if it emits smoke, an abnormal smell, or makes an unusual noise. These conditions can cause fire or electric shock. Confirm that smoke has stopped emitting and contact an authorised service centre.
- Unplug from power outlets and never touch the inside of the product if its casing has been broken open.
- Never touch the plug with wet hands. Danger of electric shock exists.

Installation

- To prevent the risk of fire or electrical shock, do not expose the product to rain or any type of moisture.
- Do not place or use this product near automatically controlled devices such as automatic doors and fire alarms. Radio waves emitted from this product may cause such devices to malfunction resulting in an accident.
- Do not allow the AC adaptor or telephone line cord to be excessively pulled, bent or placed under heavy objects.
- Do not place the handset on the base unit when battery cover is removed.

Operating safeguards

- Unplug the product from power outlets before cleaning. Do not use liquid or aerosol cleaners.
- Do not disassemble the product.
- Do not spill liquids (detergents, cleansers, etc.) onto the telephone line cord plug, or allow it to become wet at all. This may cause a fire. If the telephone line cord plug becomes wet, immediately pull it from the telephone wall jack, and do not use.
- To prevent hearing damage, make sure anyone who uses this product is aware that the product can produce very loud sounds, and make sure children use this product only under adult supervision.
- To prevent hearing damage, we recommend that you set this product to the lowest volume setting at which you can hear adequately. Note that when the  is displayed, the Amplify

Important Information

key feature is enabled and the product may emit sounds at very high volume.

- Avoid prolonged exposure to loud sounds produced by this product. Be aware that the louder a sound is, the less time is needed to cause hearing damage. In the event that you experience hearing discomfort, consult a medical professional.

Medical

- Consult the manufacturer of any personal medical devices, such as pacemakers or hearing aids, to determine if they are adequately shielded from external RF (radio frequency) energy. (The product operates in the frequency range of 1.88 GHz to 1.90 GHz, and the RF transmission power is 250 mW (max.).)
- Do not use the product in health care facilities if any regulations posted in the area instruct you not to do so. Hospitals or health care facilities may be using equipment that could be sensitive to external RF energy.

CAUTION

Installation and location

- Never install telephone wiring during an electrical storm.
- Never install telephone line jacks in wet locations unless the jack is specifically designed for wet locations.
- Never touch uninsulated telephone wires or terminals unless the telephone line has been disconnected at the network interface.

- Use caution when installing or modifying telephone lines.
- The AC adaptor is used as the main disconnect device. Ensure that the AC outlet is installed near the product and is easily accessible.
- This product is unable to make calls when:
 - the handset batteries need recharging or have failed.
 - there is a power failure.
 - the key lock feature is turned on.

Battery

- We recommend using the batteries noted on page 3. **USE ONLY rechargeable Ni-MH batteries AAA (R03) size.**
- Do not mix old and new batteries.
- Do not open or mutilate the batteries. Released electrolyte from the batteries is corrosive and may cause burns or injury to the eyes or skin. The electrolyte is toxic and may be harmful if swallowed.
- Exercise care when handling the batteries. Do not allow conductive materials such as rings, bracelets, or keys to touch the batteries, otherwise a short circuit may cause the batteries and/or the conductive material to overheat and cause burns.
- Charge the batteries provided with or identified for use with this product only, in accordance with the instructions and limitations specified in this manual.
- Only use a compatible base unit (or charger) to charge the batteries. Do not tamper with the base unit (or charger). Failure to follow these instructions may cause the batteries to swell or explode.

- Avoid the use in the following conditions:
 - High or low extreme temperatures during use, storage or transportation.
 - Replacement of a battery with an incorrect type that can defeat a safeguard.
 - Disposal of a battery into fire or a hot oven, or mechanically crushing or cutting of a battery, that can result in an explosion.
 - Extremely high temperature and/or extremely low air pressure that can result in an explosion or the leakage of flammable liquid or gas.

Important safety instructions

When using your product, basic safety precautions should always be followed to reduce the risk of fire, electric shock, and injury to persons, including the following:

1. Do not use this product near water for example, near a bathtub, washbowl, kitchen sink, or laundry tub, in a wet basement or near a swimming pool.
2. Avoid using a telephone (other than a cordless type) during an electrical storm. There may be a remote risk of electric shock from lightning.
3. Do not use the telephone to report a gas leak in the vicinity of the leak.
4. Use only the power cord and batteries indicated in this manual. Do not dispose of batteries in a fire. They may explode. Check with local codes for possible special disposal instructions.

SAVE THESE INSTRUCTIONS

For best performance

Base unit location/avoiding noise

The base unit and other compatible Panasonic units use radio waves to communicate with each other.

- For maximum coverage and noise-free communications, place your base unit:
 - at a convenient, high, and central location with no obstructions between the handset and base unit in an indoor environment.
 - away from electronic appliances such as TVs, radios, personal computers, wireless devices, or other phones.
 - facing away from radio frequency transmitters, such as external antennas of mobile phone cell stations. (Avoid putting the base unit on a bay window or near a window.)
- Coverage and voice quality depends on the local environmental conditions.
- If the reception for a base unit location is not satisfactory, move the base unit to another location for better reception.

Environment

- Keep the product away from electrical noise generating devices, such as fluorescent lamps and motors.
- The product should be kept free from excessive smoke, dust, high temperature, and vibration.
- The product should not be exposed to direct sunlight.

Important Information

- Do not place heavy objects on top of the product.
- When you leave the product unused for a long period of time, unplug the product from the power outlet.
- The product should be kept away from heat sources such as heating devices, cooking appliances, etc. It should not be placed in rooms where the temperature is less than 0 °C or greater than 40 °C. Damp basements should also be avoided.
- The maximum calling distance may be shortened when the product is used in the following places: Near obstacles such as hills, tunnels, underground, near metal objects such as wire fences, etc.
- Operating the product near electrical appliances may cause interference. Move away from the electrical appliances.

Routine care

- **Wipe the outer surface of the product with a soft moist cloth.**
- Do not use benzine, thinner, or any abrasive powder.

Other information

- The applied nameplate is located at the bottom or rear of the product.
- ⚠ CAUTION:** Risk of explosion if battery is replaced by an incorrect type. Dispose of used batteries according to the instructions.

Notice for product disposal, transfer, or return

- This product can store your private/confidential information. To protect your privacy/confidentiality, we

recommend that you erase information such as phonebook or caller list entries from the memory before you dispose of, transfer, or return the product.

Information on Disposal in other Countries outside the European Union

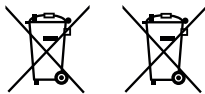

These symbols are only valid in the European Union. If you wish to discard these items, please contact your local authorities or dealer and ask for the correct method of disposal.

Note for the battery removal procedure

Refer to "Removing the battery" on page 11.

Specifications

- **Standard:**
DECT (Digital Enhanced Cordless Telecommunications),
GAP (Generic Access Profile)
- **Frequency range:**
1.88 GHz to 1.90 GHz
- **RF transmission power:**
Approx. 10 mW (average power per channel)
250 mW (max.)
- **Power source:**
100–240 V AC, 50/60 Hz

- **Rechargeable battery:**
AAA (R03) Ni-MH battery (1.2 V,
550 mAh)
- **Power consumption:**
Base unit:
Standby: 0.7 W
Maximum: 2.6 W
- **Operating conditions:**
0 °C–40 °C, 20 %–80 % relative air
humidity (dry)

Setting up

Connections

- 1 Connect the AC adaptor to the unit by pressing the plug firmly.
- 2 Fasten the cord by hooking it.
- 3 Connect the AC adaptor to the power outlet.
- 4 Connect the telephone line cord to the unit, then to the telephone line jack until you hear a click.
- 5 A DSL/ADSL filter (not supplied) is required if you have a DSL/ADSL service.

Note:

- Use only the supplied Panasonic AC adaptor PNLV226CE.
- Use only the supplied telephone line cord.

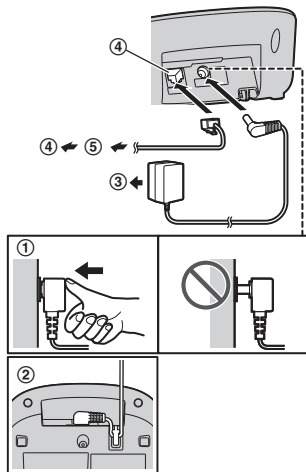

Battery installation

- USE ONLY rechargeable Ni-MH batteries AAA (R03) size (A).
- Do NOT use alkaline/manganese/Ni-Cd batteries.
- Confirm correct polarities (+, -).

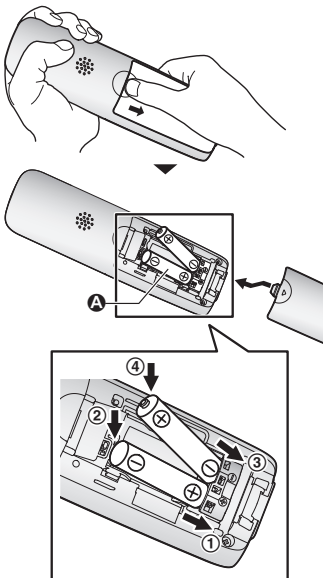

- Follow the directions on the display to set up the unit.

Removing the battery

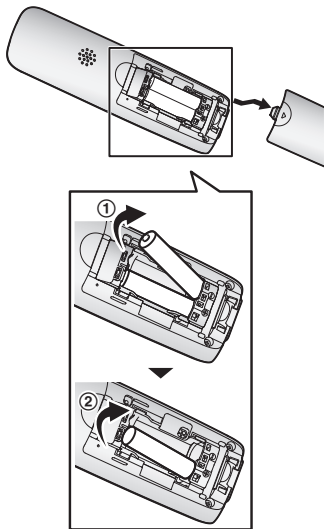

Battery charging

Charge for about 7 hours.

- Confirm “Charging” is displayed (A).
- When the batteries are fully charged, “Fully Charged” is displayed.

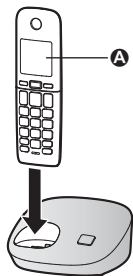

Note when setting up

Note for connections

- The AC adaptor must remain connected at all times. (It is normal for the adaptor to feel warm during use.)
- The AC adaptor should be connected to a vertically oriented or floor-mounted AC outlet. Do not connect the AC adaptor to a horizontally oriented AC outlet that faces the floor, such as an AC outlet installed on a ceiling or under a table, as the weight of the adaptor may cause it to become disconnected.

Power failure

- The unit cannot be used to make or receive calls during a power failure. We recommend connecting a corded-type telephone that does not use an AC adaptor to your telephone line.





Note for battery installation

- Use the supplied rechargeable batteries. For replacement, we recommend using the Panasonic rechargeable batteries noted on page 3, 6.

Note for battery charging

- It is normal for the handset to feel warm during charging.
- Clean the charge contacts of the handset and base unit with a soft and dry cloth once a month. Before cleaning the unit, disconnect from power outlets and any telephone line cords. Clean more often if the unit is exposed to grease, dust, or high humidity.

Battery level

Icon	Battery level
	High
	Medium
	Low
	Needs charging.

Ni-MH battery performance (supplied batteries)

Operation	Operating time
In continuous use	18 hours max.*1,*2
Not in use (standby)	250 hours max.*1,*2

*1 When eco mode is on.

*2 When torchlight or Amplify key feature is off.

Note:

- Actual battery performance depends on usage and ambient environment.

Controls

Base unit

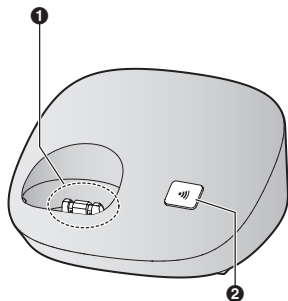

1 Charge contacts

2 (Locator)

- You can locate a misplaced handset by pressing .

Handset

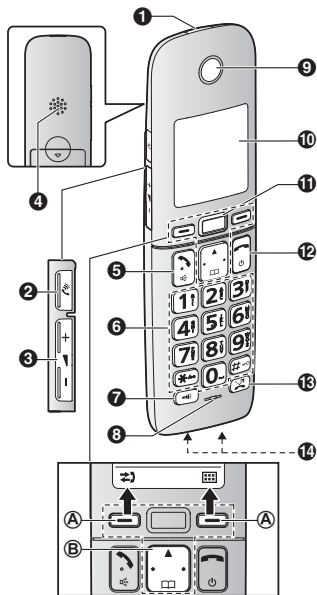

- 1 Torchlight/Ringer indicator
- 2 [📶] (Amplify key)
- 3 [⏏]/[⏏] (▲: Volume up/down)
- 4 Speaker
- 5 [📞/📞] (Talk/Speakerphone)
- 6 Dial keypad
- 7 [🔒] (Key lock)
- 8 [🔦] (Torchlight)
- 9 Receiver
- 10 Display
- 11 Favourites Key (Favourites call)
Favourites Key indicator
- 12 [🔌] (Off/Power)

13 [🚫] (Call block)

14 Charge contacts

■ Control type

Ⓐ Soft keys

By pressing a soft key, you can select the feature shown directly above it on the display.

Ⓑ Navigator key

Navigator keys functions as follows.

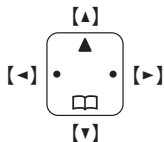



















- [▲], [▼], [◀], or [▶]: Scroll through various lists and items.
- [▲] or [▼] (▲): Adjust the receiver or speaker volume while talking.
- Right [•]: View the redial list.
- Left [•]: View the caller list.
- [📖] (Phonebook): View the phonebook entry.

Display icons/Indicators

Handset display items

Item	Meaning
	Range status: The more bars visible, the closer the handset is to the base unit.
	Out of base unit range
	Security for phone calls is set to "Enhanced". (page 42)

Item	Meaning
	Paging
	Speakerphone is on. (page 17)
	The line is in use. <ul style="list-style-type: none"> When flashing slowly: The call is on hold. When flashing rapidly: An incoming call is now being received.
	Missed call.*1 (page 44, page 52)
	Eco mode is set to "Eco". (page 15)
	Noise reduction is set. (page 19)
	The LCD and key backlight is off. (page 36)
	Battery level
	Amplify key feature is on. (page 19)
	Alarm is on. (page 38)
	Privacy mode is on.*2 (page 36)
	Ringer volume is off. (page 34)
	Do not disturb mode is on. (page 39)
	Nuisance call blocked.*1 (page 22)
	Automated call block is set to "Block".*1 (page 25)

Item	Meaning
	Automated call blocked.*3 (page 45)
	New voicemail message received.*3 (page 46)
	Baby monitor is activated. The name/number displayed next to the icon indicates the monitoring unit. (page 39)

*1 Caller ID subscribers only



*2 Although the handset displays these items, these features are not available for this model.

















*3 Voicemail subscribers only

Favourites Key indicators on the handset

Status	Meaning
Flashing	There is a missed call from a favourite contacts.
Flashing rapidly	An incoming call from a phone number registered in favourite contacts.

Handset soft key icons

Icon	Action
	Returns to the previous screen or outside call.
	Displays the menu.
OK	Accepts the current selection.



Icon	Action
	Makes a call. (page 29)
	Temporarily turns off the ringer for incoming calls. (page 18)
	Places a call on hold.*1
	Allows you to edit phone numbers. (page 23)
	Adds new entry. (page 30)
	Displays the phonebook search menu. (page 29)
	Turns the key lock feature off. (page 20)
	Stops alarm. (page 38)
	Snooze button on the alarm. (page 38)
	Selects entries or handset. (page 38)
	Stops playback.
	Stores phone numbers. (page 28)
	Erases the selected item.
	Allows you to make an intercom call.*1
	Erases a number/character.
	Puts the call on mute.
	View the caller log.

*1 Although the handset displays these items, these features are not available for this model.

Turning the power on/off

Press [] for about 2 seconds.

Date and time

- []#101
- Enter the current date, month, and year. → [OK]
Example: 12 July, 2024
12 07 24
- Enter the current hour and minute.
Example: 9:30
09 30
 - You can select 24-hour or 12-hour clock format (“AM” or “PM”) by pressing [].
- [OK] → []

Other settings

Eco mode

The following settings are available for eco mode.

- “Eco”: Reduces the base unit transmission power by up to 90 % in standby mode.
When this setting is selected, **ECO** is displayed on the handset display instead of .
- “off” (default setting): Turns off eco mode.
When this setting is selected, **ECO** are not displayed on the handset display.

Setting the eco mode

- 1 **[]#725**
- 2 **[]**: Select the desired setting. →
[OK] → []

Note:

- When eco mode is active, the range of the base unit is reduced in standby mode.

Dialling mode

If you cannot make calls, change this setting according to your telephone line service. The default setting is “**Tone**”.

“**Tone**”: For tone dial service.

“**Pulse**”: For rotary/pulse dial service.

- 1 **[]#120**
- 2 **[]**: Select the desired setting.
- 3 **[OK] → []**

Torchlight/Ringer indicator

The indicator is located at the top of handset. There are two features available.

■ Torchlight



Press **[]** to turn the torchlight on/off. The maximum lighting time is about 5 minutes.

■ Ringer indicator

The LED flashes rapidly to indicate the unit status under the following conditions:

- an incoming call.
- intercom is being received.

The default setting is “**On**”.

- 1 **[]#345**
- 2 **[]**: Select the desired setting. →
[OK] → []

Note:

- When the torchlight is turned on while receiving an incoming call, the ringer indicator will not work.

Low battery alert



When this feature is turned on, the unit notifies you by beeping 3 times at the selected interval if the battery needs charging when the handset is in standby mode.

Note for handset:

- At the end of each call, the unit displays a large icon for a few moments to indicate the battery level.

Setting low battery alert

To turn this feature on, select the desired alert interval, or select “**Off**” to turn this feature off. The default setting is “**Every Hour**”.

- 1 **[]#176**
- 2 **[]**: Select the desired setting. →
[OK] → []

Making calls

- 1 Lift the handset and then dial the phone number.
 - To correct a digit, press [C].
- 2 Press [📞/📞] to make the call.
 - To make the call using the speakerphone, press and hold [📞/📞] for a few second.
- 3 When you finish talking, press [📞] or place the handset on the base unit.

Note:

- While talking, you can switch between the receiver and the speakerphone by pressing [📞/📞].
- In step 1, you can store the dialled phone number to the phonebook by pressing [📞].

Adjusting the receiver or speaker volume

Press either [▲] or [▼] on the navigator key, or [+] or [-] located on the side of the handset repeatedly, to select the desired volume while talking.

Note:

- Pressing the [👉] key activates the Amplify key feature. Use this key with care. To prevent hearing damage, we recommend that you set this product to the lowest volume setting at which you can hear adequately (page 19).

Making a call using the redial list

The last 10 phone numbers dialled are stored in the redial list (24 digits max. each).

- 1 Press right [●] navigator key.
 - Or press [↔] (left soft key).
If the caller list is displayed, press right [●] navigator key to switch to the redial list.
- 2 [↕]: Select the desired entry.
- 3 [📞/📞]

Erasing a number in the redial list

- 1 Press right [●] navigator key.
 - Or press [↔] (left soft key).
If the caller list is displayed, press right [●] navigator key to switch to the redial list.
- 2 [↕]: Select the desired entry. → [X]
- 3 [↕]: "Yes" → [OK] → [📞]

Pause (for PBX/long distance service users)

A pause is sometimes required when making calls using a PBX or long distance service. When storing a calling card access number and/or PIN in the phonebook, a pause is also needed (page 29).

Example: If you need to dial the line access number "0" when making outside calls with a PBX:

- 1 [0] → [▲] (Pause)
- 2 Dial the phone number. → [📞/📞]

Note:

- A 3 second pause is inserted each time [▲] (Pause) is pressed.

Answering calls

When a call is being received, the ringer indicator flashes rapidly according to its settings. (page 16)

- 1 Lift the handset and press [/📞] when the unit rings.
- 2 When you finish talking, press [] or place the handset on the base unit.

Any key answer: You can answer the call by pressing any dial key.

Auto talk: You can answer calls simply by lifting the handset (page 36).

Temporary handset ringer off: You can turn the ringer off temporarily by pressing [] (left soft key).

Adjusting the ringer volume

Press either [] or [] on the navigator key, or [] or [] located on the side of the handset repeatedly, to select the desired volume while ringing.

- To turn the ringer off, press either [] or [] repeatedly.

Note:

- To change the ringer volume and ringer tone for an outside call, see page 34.

Useful features during a call

Hold

- 1 Press [] during an outside call.
- 2 []: “Hold” → [OK]
- 3 To release hold, press [/📞].

Note:

- After holding for 10 minutes, the call is disconnected.

Mute

- 1 Press [] during a call.
- 2 To return to the call, press [].

Recall/flash

Press [] during an outside call. → []: “Recall” → [OK]

allows you to use the special features of your host PBX such as transferring an extension call, or accessing optional telephone services.

Note:

- To change the recall/flash time, see page 36.

For call waiting or Call Waiting Caller ID service users

To use call waiting or Call Waiting Caller ID, you must first subscribe with your phone service provider.

This feature allows you to receive calls while you are already talking on the phone. If you receive a call while on the phone, you will hear a call waiting tone.

If you subscribe to Call Waiting with Caller ID services, the 2nd caller's information is displayed on the unit that is in use after you hear the call waiting tone.

- 1 To answer the 2nd call, Press [] during an outside call. → []: “Recall” → [OK]

- 2 To switch between calls,
Press **[☒]** during an outside call.
→ **[↕]**: “Recall” → **[OK]**

Note:

- Please contact your phone service provider for details and availability of this service in your area.

Amplify key feature

This feature allows you to substantially increase the volume of the other party's voice. This feature can be set for each unit.

Amplify key feature is working under the following features:

- Making call (page 17).
- Answering call (page 18).
- Monitoring with a handset (page 39).

WARNING

- This feature is designed for users who are hard of hearing. If other users use the phone, be sure to turn this feature off.
- Do not use this feature unnecessarily. High volume emitted from the product may cause hearing damage.
- Pressing the **[👂]** key activates the Amplify key feature. Use this key with care. To prevent hearing damage, we recommend that you set this product to the lowest volume setting at which you can hear adequately.

Setting the amplify volume mode

- 1 **[☒]#279**
- 2 **[↕]**: Select the desired setting. → **[OK]** → **[👂]**

Turning the Amplify key feature on/off

- 1 Press **[👂]** while on a call.
 - The unit displays **👂**.
- 2 Press either **[▲]** or **[▼]** on the navigator key, or **[+]** or **[-]** located on the side of the handset repeatedly, to select the desired volume while talking.

Note:

- When the amplify volume mode is set to “Normal”:
 - If the receiver volume is set to level 5 (max.), it will be changed to level 4 in the next call.
 - If the Amplify key feature is on, it will be changed to off in the next call.
- When the amplify volume mode is set to “Amplified”:
 - The previous receiver volume level and Amplify key feature on/off status will continue in the next call.
- This feature is not available while using the speakerphone.

Temporary tone dialling (for rotary/pulse service users)

Press **[✖]** before entering access numbers which require tone dialling.

Handset noise reduction

This feature allows you to hear the voice of the person you are talking to more clearly, by reducing the surrounding noise coming from the other party's telephone.

- 1 Press **[☒]** while talking.

Making/Answering Calls

- 2 : “Noise Reduction On” or “Noise Reduction Off” → [OK]

Note:

- Depending on the environment where this handset is being used, this feature may not be effective.
- This feature is not available while using the speakerphone.

Handset equalizer

This feature clarifies the voice of the person you are talking to, producing a more natural-sounding voice that is easier to hear and understand.

- 1 Press while talking.
- 2 : “Equalizer” → [OK]
- 3 : Select the desired setting.
- 4 Press [OK] to exit.

Note:

- Depending on the condition and quality of your telephone line, this feature may emphasise existing line noise. If it becomes difficult to hear, select another setting.
- This feature is not available while using the speakerphone.

Key lock

The handset can be locked so that no calls or settings can be made. Incoming calls can be answered, but most other functions are disabled while the key lock is on.

You can select to lock the handset with or without a password. The default setting is “without Password”. When you turn the key lock feature on, “O” is displayed.

Important:

- Calls to emergency numbers cannot be made until key lock is turned off.

Setting the key lock mode

- 1 #246
- 2 : Select the desired setting. → [OK] →

Turning the key lock on/off

■ Without a password:

Press for about 3 seconds during standby mode.

■ With a password:

- 1 Press for about 3 seconds during standby mode.
- 2 Enter your key lock password (4 digits). → [OK] 2 times
 - If you forget your password, contact an authorized service centre.

Note:

- You can turn off the handset while the key lock is on. Depending on the settings, the state of the handset may change when you turn on the handset again:
 - Without a password: The key lock turns off.
 - With a password: The key lock stays on.
- The following keys and operations are available when the key lock is on:
 - to stop the alarm.
 - Without a password: During a call, all available features can be used as usual. When the call ends, the handset turns the key lock on again.
- When the key lock mode is set to “with Password”:

- Dial keypad and right **[•]** navigator key (to view redial list) cannot be used during a call.
- **[↶]** (right soft key) is not available during chain dial (page 29).

Nuisance call block

You can press the [📞] key in the following situations to disconnect the current call and add a phone number to the call block list:

- when an incoming call is being received
- when talking on an outside call

Once a phone number has been added to the call block list, the unit will block calls from that phone number in the future.

- 1 Press [📞] under the situations shown above.
- 2 Confirm the call block number and press [OK].
 - The call block number is stored in the call block list, “Call Blocked” is displayed, and then the call is disconnected.

Note:

- If the call has no phone number, the call is blocked but it is not stored in the call block list.
- The call block feature is not available for calls received by call waiting.
- Blocked calls are logged in the caller list.

Storing unwanted callers

The unit can block calls by storing the desired items in the call block list beforehand.

- “**Single Number**”: The unit blocks calls from specific phone numbers stored in the call block list.

- “**Range of Numbers**”: The unit blocks calls that begin with a number stored in the call block list, such as a toll-free phone number prefix or certain area codes.

- “**Withheld**”: The unit blocks calls that have no phone number.

However, this option may not be available in the following situations:

- If the caller dials from an area which does not provide a Caller ID service.
- International calls.

Single phone numbers and ranges of numbers can be stored in the call block list up to 1,000 items in total.

Blocking unwanted callers:

When a call is received, the unit does not ring while the caller is being identified.

If the caller’s phone number matches an entry in the call block list, the unit emits no sound to the caller, and disconnects the call.

Storing a single phone number

Important:

- You must include the area code when storing phone numbers in the call block list.

Adding call blocked numbers from the caller list

- 1 Press left [•] navigator key.
 - Or press [↔] (left soft key).
If the redial list is displayed, press left [•] navigator key to switch to the caller list.
- 2 [↕]: Select the desired entry to be blocked.

- 3 [M] → [↕]: “Yes” → [OK] → [⏻]

Adding call blocked numbers manually

- 1 [M]
- 2 [↕]: “Nuisance Call Block” → [OK]
- 3 [↕]: “Single Number” → [OK]
- 4 [☒] → [↕]: “Add” → [OK]
- 5 Enter the phone number (24 digits max.). → [OK] → [⏻]

Storing a range of numbers

- 1 [M]
- 2 [↕]: “Nuisance Call Block” → [OK]
- 3 [↕]: “Range of Numbers” → [OK]
- 4 [☒] → [↕]: “Add” → [OK]
- 5 Enter the desired number (2-8 digits). → [OK] → [⏻]

Blocking incoming calls that have no phone number

You can block calls when no phone number is provided, such as private callers.

- 1 [M]
- 2 [↕]: “Nuisance Call Block” → [OK]
- 3 [↕]: “Withheld” → [OK]
- 4 [↕]: Select the desired setting. → [OK] → [⏻]

Viewing/editing/erasing call block numbers

- 1 [M]
- 2 [↕]: “Nuisance Call Block” → [OK]
- 3 [↕]: “Single Number” or “Range of Numbers” → [OK]
- 4 [↕]: Select the desired entry.
 - After viewing, press [⏻] to exit.
- 5 **To edit a number:**
[☒] → Edit the number. → [OK] → [⏻]
To erase a number:
[X] → [↕]: “Yes” → [OK] → [⏻]

Note:







- When editing, press the desired dial key to add digits and press [C] to erase digits.

Erasing all call block numbers

- 1 [M]
- 2 [↕]: “Nuisance Call Block” → [OK]
- 3 [↕]: “Single Number” or “Range of Numbers” → [OK]
- 4 [☒] → [↕]: “Erase All” → [OK]
- 5 [↕]: “Yes” → [OK]
- 6 [↕]: “Yes” → [OK] → [⏻]

Displaying and clearing the blocked call count

The total number of blocked calls (up to 65,000) will be displayed.

- 1 [
- 2 []: "Nuisance Call Block"
→ [OK]
- 3 []: "Blocked Calls Count"
→ [OK]
 - To exit, press [].
- 4 [C]
- 5 []: "Yes" → [OK] → [

Automated call block

Automated call block means the unit screens incoming calls before ringing. If the call is allowed, the unit will ring. If the call is identified as an automated/telemarketing call, the unit will not ring. The unit will play a greeting message to the caller and prompt them to enter an access code.

This enables the unit to identify whether the call is automated. You can set the unit to block or unblock mode. The default setting is "Unblock".

Note:

- The unit connects the call without prompting to enter access code in the following situations:
 - the caller's phone number matches an entry in the phonebook (page 28).
 - the caller's phone number matches an entry in the Favourites Key (page 30).
 - the caller's name matches an entry in the allow name list (page 26).
 - the caller's phone number is memorised in the allowed number database (page 25).
- If the number is stored in the call block list (page 22), the unit disconnects the call without playing the greeting message for automated call block.
- When the unit receives a call from a caller who is not registered in the phonebook, Favourites Key, allow name list, or allowed number database in the following situations, the unit shifts to standby mode:

- when searching the phonebook, Favourites Key, caller list, call block list, or allow name list
- when programming (depending on settings)
- Blocked calls are logged in the caller list. We recommend you to check the caller list periodically. If necessary, register the entry to the phonebook, Favourites Key, or allow name list to connect the call next time.

Allowed number database





Once the caller enters the access code, the caller's phone number is memorised in the allowed number database as an unblocked number. Callers from this database are allowed to connect without the access code from their next call.

100 entries can be stored to the database (22 digits max. each).

Note:

- When the database memory is full, the latest call received will replace the oldest number stored in the list.
- The numbers stored in the database will be erased when you change the access code (page 26).
- The numbers stored in the database cannot be displayed.

Setting the automated call block

- 1  → [OK]
- 2 : "Block/Unblock" → [OK]
- 3 : Select the desired setting. → [OK]
- 4 : "Yes" → [OK] → 

Automated Call Block

Note:

- We recommend you perform a test run of the automated call block procedure to ensure that the automated call block feature is set correctly.

Changing the access code

If the unit answers undesirable calls such as automated calls even though the automated call block function is on, change the access code (3 digits max.). The default setting is "1".

- 1 [↖] → [OK]
- 2 [↓]: "Access Code" → [OK]
- 3 [C]
- 4 Enter the new access code. → [OK] → [🔒]

Displaying and clearing the blocked call count

The total number of blocked calls (up to 65,000) will be displayed.

- 1 [↖] → [OK]
- 2 [↓]: "Blocked Calls Count" → [OK]
 - To exit, press [🔒].
- 3 [C]
- 4 [↓]: "Yes" → [OK] → [🔒]

Adding to the allow name list

You can allow specific callers to pass through by adding the caller's name to the allow name list even if you do not know the caller's number.

You can store up to 100 names (16 characters max.). If the name stored in the allow name list matches the

incoming Caller ID, the unit rings. Callers listed in the allow name list are not required to enter the access code.

Adding allowed names from the caller list

- 1 Press left [●] navigator key.
 - Or press [↵] (left soft key). If the redial list is displayed, press left [●] navigator key to switch to the caller list.
- 2 [↓]: Select the desired entry. → [📄]
- 3 [↓]: "Save Allow Name" → [OK] → [🔒]

Viewing/erasing an entry

- 1 [↖] → [OK]
- 2 [↓]: "Allow Name List" → [OK]
- 3 [↓]: Select the desired entry.
 - After viewing, press [🔒] to exit.
- 4 [X] → [↓]: "Yes" → [OK] → [🔒]

Erasing all entries

- 1 [↖] → [OK]
- 2 [↓]: "Allow Name List" → [OK]
- 3 [X] → [↓]: "Yes" → [OK]
- 4 [↓]: "Yes" → [OK] → [🔒]

Greeting message for automated call block

When the unit answers a call, a greeting message is played to the caller.

Playing back the greeting message for automated call block

- 1 [📞] → [OK]
- 2 [↕]: “Automated Call
Greeting” → [OK]
- 3 [↕]: “Play Greeting” → [OK]
- 4 To exit, press [🔴].

Phonebook

You can add 200 names (16 characters max.) and phone numbers (24 digits max.) to the phonebook, and assign each phonebook entry to the desired category (page 28).

Adding phonebook entries

- 1 [OK] → [Grid]
- 2 [↕]: "New Entry" → [OK]
- 3 Enter the party's name. → [OK]
 - You can change the character entry mode by pressing [#] (page 46).
- 4 Enter the party's phone number. → [OK]
- 5 [↕]: Select the desired category. → [OK] 2 times → [Phone]

Storing a redial list number to the phonebook

- 1 Press right [•] navigator key.
 - Or press [↵] (left soft key). If the caller list is displayed, press right [•] navigator key to switch to the redial list.
- 2 [↕]: Select the desired entry. → [Grid]
- 3 To store the name, continue from step 3, "Editing entries", page 29.

Storing caller information to the phonebook

- 1 Press left [•] navigator key.
 - Or press [↵] (left soft key). If the redial list is displayed, press left [•] navigator key to switch to the caller list.

- 2 [↕]: Select the desired entry. → [Grid]
- 3 [↕]: "Save Phonebook" → [OK]
- 4 To store the name, continue from step 3, "Editing entries", page 29.

Categories

Categories can help you find entries in the phonebook quickly and easily. You can change the names of categories ("Friends", "Family", etc.). By assigning different ringer tones for different categories of callers, you can identify who is calling (category ringer tone).

Changing category names/setting category ringer tone

- 1 [OK] → [Grid]
- 2 [↕]: "Category" → [OK]
- 3 [↕]: Select the desired category. → [OK]
- 4 To change category names [↕]: "Category Name" → [OK] → Edit the name (10 characters max.). → [OK]
To set category ringer tone [↕]: Select the current setting of the category ringer tone. → [OK] → [↕]: Select the desired ringer tone. → [OK]
- 5 [Phone]

Finding and calling from a phonebook entry

- 1 [OK]
- 2 To scroll through all entries [↕]: Select the desired entry.
To search by first character ① Press the dial key ([0] to [9], or [#]) which contains the

character you are searching for (page 46).

- ② [↕]: Scroll through the phonebook if necessary.

To search by category

- ① [☞] → [↕]: “Category” → [OK]
- ② [↕]: Select the desired category. → [OK]
- ③ [↕]: Scroll through the phonebook if necessary.

3 [↶/☎]

Editing entries

- 1 Find the desired entry (page 28). → [☑]
- 2 [↕]: “Edit” → [OK]
- 3 Edit the name if necessary. → [OK]
- 4 Edit the phone number if necessary. → [OK]
- 5 [↕]: Select the desired category (page 28). → [OK] 2 times → [☎]

Erasing entries

Erasing an entry

- 1 Find the desired entry (page 28). → [☑]
- 2 [↕]: “Erase” → [OK]
- 3 [↕]: “Yes” → [OK] → [☎]

Erasing all entries

- 1 [☐] → [☑]
- 2 [↕]: “Erase All” → [OK]
- 3 [↕]: “Yes” → [OK]
- 4 [↕]: “Yes” → [OK] → [☎]

Chain dial

This feature allows you to dial phone numbers in the phonebook while you are on a call. This feature can be used, for example, to dial a calling card access number or bank account PIN that you have stored in the phonebook, without having to dial manually.

- 1 During an outside call, press [☑].
- 2 [↕]: “Phonebook” → [OK]
- 3 Continue from step 2, “Finding and calling from a phonebook entry”, page 28.
- 4 Press [↶] (right soft key) to dial the number.

Note:

- When storing a calling card access number and your PIN in the phonebook as one phonebook entry, press [▲] (Pause) to add pauses after the number and PIN as necessary (page 17).
- If you have rotary/pulse service, you need to press [✕] before pressing [☑] in step 1 to change the dialling mode temporarily to tone. When adding entries to the phonebook, we recommend adding [✕] to the beginning of phone numbers you wish to chain dial (page 28).

Speed dial

You can assign 1 phone number to each of the dial keys (1 to 9) on the handset.

Adding phone numbers to speed dial keys

■ By entering phone numbers:

- 1 Press and hold the desired speed dial key (1 to 9). → [☐] → [☐←]
- 2 [↕]: "Manual" → [OK]
- 3 Enter the party's name (16 characters max.). → [OK]
- 4 Enter the party's phone number (24 digits max.). → [OK] 2 times → [📞]

■ From the phonebook:

- 1 Press and hold the desired speed dial key (1 to 9). → [☐] → [☐←]
- 2 [↕]: "Phonebook" → [OK]
- 3 [↕]: Select the desired entry. → [OK] → [📞]

Note:

- If you edit a phonebook entry which is assigned to a speed dial key, the edited entry does not transfer to the speed dial key.

Editing an entry

- 1 Press and hold the desired speed dial key (1 to 9). → [☐]
- 2 [↕]: "Edit" → [OK]
- 3 Edit the name if necessary. → [OK]
- 4 Edit the phone number if necessary. → [OK] 2 times → [📞]

Erasing an entry

- 1 Press and hold the desired speed dial key (1 to 9). → [☐]
- 2 [↕]: "Erase" → [OK]
- 3 [↕]: "Yes" → [OK] → [📞]

Viewing an entry/Making a call

- 1 Press and hold the desired speed dial key (1 to 9).
- 2 To make a call, press [📞].

Favourites Key

You can add up to 3 favourite names (16 characters max.), phone numbers (24 digits max.) and the desired ringer tone to the Favourites Key. The Favourites Key indicator flashes once you have set your favourite contacts information (page 14).

Important:

- Make sure the unit's date and time setting is correct (page 15).
- This unit is Caller ID compatible. To use Favourites Key indicator and ringer tones features, you must subscribe to a Caller ID service. Contact your phone service provider for details.

Note:

- Favourite contacts are a common feature within the system.

Adding phone numbers manually to Favourites Key

- 1 [☐]#295

- 2 : Select the desired entry. →
- 3 Enter the party's name. → [OK]
- 4 Enter the party's phone number. → [OK]
- 5 : Select the desired ringer tone. → [OK] 2 times →

Finding and calling from Favourites Key

- 1 Press Favourites Key.
- 2 : Select desired entry.
- 3 Press or Favourites Key to make the call.

Answering call from Favourites Key

- 1 Lift the handset and then press Favourites Key or when the unit rings.
- 2 When you finish talking, press .

Note:

- If there is a missed call from the favourite contacts, it will not be listed in the caller list. Instead, the Favourites Key will flash slowly to let you know there is a missed call from the favourite contacts.

To view:

- ① Press Favourites Key.
 - ② : Select the desired entry. → [OK]
- If the indicator flashes when the handset is not placed on the base unit, battery consumption will be faster than usual.

Editing a favourites caller's phone number

- 1 #295
- 2 : Select desired entry. →
- 3 : "Edit" → [OK]
- 4 Edit the name if necessary. → [OK]
- 5 Edit the phone number if necessary. → [OK]
- 6 : Select the desired ringer tone if necessary. → [OK] 2 times →

Viewing the favourites information

- 1 #295
- 2 : Select desired entry. →
- 3 : "Detail" → [OK]
- 4

Erasing an entry

- 1 #295
- 2 : Select desired entry. →
- 3 : "Erase" → [OK]
- 4 : "Yes" → [OK] →



Menu list

To access the features, there are 2 methods.



■ Scrolling through the display menus

- 1 
- 2 Press **[▼]**, **[▲]**, **[▶]**, or **[◀]** to select the desired main menu. → **[OK]**
- 3 Press **[▼]** or **[▲]** to select the desired item from the next sub-menus. → **[OK]**
- 4 Press **[▼]** or **[▲]** to select the desired setting. → **[OK]**

■ Using the direct command code

- 1  → Enter the desired code.
Example: Press #101.
- 2 Select the desired setting. → **[OK]**

Note:

- To exit the operation, press .
- In the following table, < > indicates the default settings.
- In the following table,  indicates the reference page number.
- Display menu order and sub-menu may vary depending on your model.

Display the menu tree and direct command code table

Main menu:  "Time Settings"

Sub-menu 1	Sub-menu 2	Settings	Code	
Set Date/Time	—	—	#101	15
Memo Alarm	Alarm1-3	<Off> Once Daily Weekly	#720	38
Time Adjustment*1	—	Caller ID <Manual>	#226	—

Main menu:  "Ringer Setup"

Sub-menu 1	Sub-menu 2	Settings	Code	
Ringer Volume (External)	—	Off-6 <6>	#160	—

Sub-menu 1	Sub-menu 2	Settings	Code	
Ringer Volume (Intercom) ^{*2}	-	1-6 <6>	#175	-
Ringtone (External) ^{*3}	-	<Ringtone 1>	#161	-
Ringtone (Intercom) ^{*2,*3}	-	<Ringtone 6>	#163	-
Do Not Disturb Mode	On/Off	On <Off>	#238	39
	Start/End	<23:00/06:00>	#237	39
	Ring Delay	30 sec. <60 sec.> 90 sec. 120 sec. No Ringing	#239	39
	Select Category	Favourite 1-3 Category 1-9	#241	39
First Ring ^{*4}	-	<On> Off	#173	-
Ringer Indicator	-	<On> Off	#345	16

Main menu:  "Intercom"^{*2}

Operation	Code	
Paging the desired unit.	#274	-

Programming

Main menu:  "Initial Setup"

Sub-menu 1	Sub-menu 2	Settings	Code	
Ringer Setup	Ringer Volume (External)	Off-6 <6>	#160	-
	Ringer Volume (Intercom) ^{*2}	1-6 <6>	#175	-
	Ringtone (External) ^{*3}	<Ringtone 1>	#161	-
	Ringtone (Intercom) ^{*2,*3}	<Ringtone 6>	#163	-
	Do Not Disturb Mode - On/Off	On <Off>	#238	39
	Do Not Disturb Mode - Start/End	<23:00/06:00>	#237	39
	Do Not Disturb Mode - Ring Delay	30 sec. <60 sec.> 90 sec. 120 sec. No Ringing	#239	39
	Do Not Disturb Mode - Select Category	Favourite 1-3 Category 1-9	#241	39
	First Ring ^{*4}	<On> Off	#173	39
Ringer Indicator	<On> Off	#345	16	
Time Settings	Set Date/Time	-	#101	15
	Memo Alarm - Alarm1-3	<Off> Once Daily Weekly	#720	38
	Time Adjustment ^{*1}	Caller ID <Manual>	#226	-

Sub-menu 1	Sub-menu 2	Settings	Code	
Talking Caller ID	–	<On> Off	#162	44
Amplify Volume Mode	–	<Normal> Amplified	#279	19
Low Battery Alert	–	Off <Every Hour> Every 3 Hours Every 6 Hours	#176	16
Automated Call Block	Block/Unblock	Block <Unblock>	#787	25
	Allow Name List	–	#794	26
	Access Code	<1>	#789	26
	Automated Call Greeting	Play Greeting	#792	27
	Blocked Calls Count	–	#790	26
Nuisance Call Block	Single Number	–	#217	22
	Range of Numbers	–		
	Withheld	On <Off>	#240	23
	Blocked Calls Count	–	#177	24
Favourites Key	–	–	#295	30
Speed Dial	–	–	#261	29
Eco Mode	–	<Off> Eco	#725	15
Security	–	<Normal> Enhanced	#729	42

Programming

Sub-menu 1	Sub-menu 2	Settings	Code	
Display Setup	LCD & Key Backlight	<On> Off	#276	–
	Contrast (Display contrast)	Level 1–4 <2>	#145	–
	Handset Name	–	#104	41
	Display Name	On <Off>	#105	42
Auto Intercom ^{*2}	–	On <Off>	#273	–
Keytones	–	<On> Off	#165	–
Area Code	–	–	#255	–
Key Lock Mode	–	with Password <without Password>	#246	20
Call Restrict	–	–	#256	42
Auto Talk ^{*5}	–	On <Off>	#200	18
Line Setup	Dial Mode	<Tone> Pulse	#120	16
	Recall/Flash Time ^{*6}	80 msec. 90 msec. 100 msec. 110 msec. 160 msec. 200 msec. 250 msec. 300 msec. 400 msec. <600 msec.> 700 msec. 900 msec.	#121	18
Privacy Mode ^{*7}	–	On <Off>	#194	–
Base Unit PIN	–	<0000>	#132	42

Sub-menu 1	Sub-menu 2	Settings	Code	
Register	Register Handset	–	#130	54
	Cancel Register*8	–	#131	55

Main menu:  "Baby Monitor"

Sub-menu 1	Sub-menu 2	Settings	Code	
On/Off	–	On <Off>	#268	40
Sensitivity Level	–	Low <Middle> High	#269	41

Main menu:  "Caller List"

Operation	Code	
Viewing the caller list.	#213	45

- *1 This feature allows the unit to automatically adjust the date and time each time caller information including date and time is received.
To turn this feature on, select "Caller ID". To turn this feature off, select "Manual".
To use this feature, set the date and time first (page 15).
- *2 Although the handset displays these items, these features are not available for this model.
- *3 The preset melodies in this product ("Ringtone 3" - "Ringtone 40") are used with the permission of © 2012 - 2017 Copyrights Vision Inc.
- *4 If you do not want the unit to ring before the caller information is received, set to "off". (Caller ID subscribers only)
You can only remove the first ring if the unit rings 2 times or more by default, which depends on your phone service provider.
- *5 If you subscribe to a Caller ID service and want to view the caller's information after lifting up the handset to answer a call, turn off this feature.
- *6 The recall/flash time depends on your telephone exchange or host PBX. Contact your PBX supplier if necessary.
- *7 To prevent other users from joining your conversations with outside callers, turn this feature on.
- *8 This menu is not displayed when scrolling through the display menus. It is only available in direct command code.

Alarm

An alarm sounds at the set time for 1 minute and is repeated 5 times at 5 minute intervals (snooze function). A text memo can also be displayed for the alarm. A total of 3 separate alarm times can be programmed. You can set one of 3 different alarm options (once, daily, or weekly) for each alarm time.

Important:

- Make sure the unit's date and time setting is correct (page 15).

- 1 [☐]#720
- 2 [↕]: Select the desired alarm. → [OK]
- 3 [↕]: Select the desired alarm option. → [OK]

"Off" Turns alarm off. Go to step 9.
"Once" An alarm sounds once at the set time.
"Daily" An alarm sounds daily at the set time. Go to step 3.
"Weekly" Alarm sounds weekly at the set time(s).

- 4 Proceed with the operation according to your selection in step 3.
 - **Once:**
Enter the desired date and month. → [OK]

■ Weekly:

[↕]: Select the desired day of the week and press [✓]. → [OK]

- 5 Set the desired time. → [OK]
- 6 Enter a text memo (10 characters max.). → [OK]
- 7 [↕]: Select the desired alarm tone. → [OK]
 - We recommend selecting a different ringer tone from the one used for outside calls.
- 8 [↕]: Select the desired snooze setting. → [OK]
- 9 [OK] → [🔔]

Note:

- Press [🔇] to stop the alarm completely.
- When the handset is in use, the alarm will not sound until the handset is in standby mode.
- Press any dial key or [🔇] to stop the sound but keep the snooze function activated.
- If you want to make an outside call when the snooze function is activated, please stop the snooze function before making the call.

Do not disturb mode

Do not disturb mode allows you to select a period of time during which the handset will not ring for outside calls. This feature is useful for time periods when you do not want to be disturbed, for example, while sleeping. Using the phonebook's category feature (page 28), you can also select categories of callers whose calls

override do not disturb mode and ring the handset.

Important:

- Make sure the unit's date and time setting is correct (page 15).
- If you have set the alarm, the alarm sounds even if do not disturb mode is turned on.

Turning do not disturb mode on/off

- 1 **[☰]#238**
- 2 **[↕]**: Select the desired setting. → **[OK]**
 - If you select "OFF", press **[🔔]** to exit.
- 3 Enter the desired hour and minute you wish to start this feature. → **[OK]**
- 4 Enter the desired hour and minute you wish to end this feature. → **[OK]** → **[🔔]**

Changing the start and end time

- 1 **[☰]#237**
- 2 Continue from step 3, "Turning do not disturb mode on/off", page 39.

Setting the ring delay

This setting allows the handset to ring during do not disturb mode if the caller waits long enough. After the selected amount of time passes, the handset rings. If you select "No Ringing", the handset never rings during do not disturb mode.

- 1 **[☰]#239**
- 2 **[↕]**: Select the desired setting. → **[OK]** → **[🔔]**

Selecting categories to bypass do not disturb mode

- 1 **[☰]#241**
- 2 **[↕]**: Select the desired categories. → **[✓]**
 - "✓" is displayed next to the selected category numbers.
 - To cancel the selected category: **[↕]**: Select the category. → Press **[✓]** again. "✓" disappears.
- 3 **[OK]** → **[🔔]**

Note:

- In addition to the phonebook categories, you can select 3 people registered in favourite contacts.

Baby monitor

This feature allows you to listen in on a room where the handset is located, allowing you to easily monitor from different areas of the house or place. The monitored handset (placed in a baby's room, for example) will automatically call the phone number stored when it detects sound.

Important:

- Before using this feature, we recommend that you test this feature and adjust the baby monitor sensitivity as needed, especially if you plan to monitor from outside.
- This feature should not be used as a substitute for a medical or caregiver's supervision. It is the caregiver's responsibility to stay close enough to handle any eventuality.

Note:

- During the monitoring mode, battery consumption is faster than usual. We recommend leaving the monitored handset on the base unit.
- The monitored handset never rings while it is being monitored.

Setting the baby monitor

Perform the setting operation with the handset to be monitored (for example, the handset placed in a baby's room).

To monitor with a handset

The internal baby monitor feature is available between handsets in the same radio cell.

- 1 # 2 6 8
- 2 : "On" → [OK]
- 3 : Select the desired handset number to monitor with. → [OK]
 - "Baby Monitor" will be displayed.
 - The registered handset name/number is displayed.

Note:

- When this feature is on, another handset can hear the monitored handset by making an intercom call.

To monitor from an outside line

If you enable this feature, the unit will call a pre-programmed phone number when the handset detects sound. After you answer the call, you can listen in on the room where the handset is located.

■ From the phonebook:

- 1 # 2 6 8
- 2 : "On" → [OK]

- 3 : Select "External" to monitor from an outside line. →
- 4 : "Phonebook" → [OK]
- 5 : Select the phonebook entry. → [OK]
 - "Baby Monitor" will be displayed.

Note:

- If you edit a phonebook entry which is assigned for monitoring, the edited entry does not transfer to the monitor.

■ By entering phone numbers:

- 1 # 2 6 8
- 2 : "On" → [OK]
- 3 : Select "External" to monitor from an outside line. →
- 4 : "Manual" → [OK]
- 5 Enter the desired name. → [OK]
- 6 Enter the desired number. → [OK] 2 times
 - "Baby Monitor" will be displayed.

Note:

- The registered name/number is displayed.

Turning off the baby monitor

The monitored handset cannot be used while baby monitor is set to "On".

- 1 Press on the handset being monitored.
- 2 : "On/Off" → [OK]
- 3 : "Off" → [OK] →

Editing an outside monitoring number

- 1 Press **[*]** on the handset being monitored.
- 2 **[↕]**: "On/Off" → **[OK]**
- 3 **[↕]**: "On" → **[OK]**
- 4 **[↕]**: Select the outside line.
- 5 **[*]** → **[↕]**: "Edit" → **[OK]**
- 6 Edit the name if necessary. → **[OK]**
- 7 Edit the phone number if necessary. → **[OK]** 2 times

Erasing an outside monitoring number

- 1 Press **[*]** on the handset being monitored.
- 2 **[↕]**: "On/Off" → **[OK]**
- 3 **[↕]**: "On" → **[OK]**
- 4 **[↕]**: Select the outside line.
- 5 **[*]** → **[↕]**: "Erase" → **[OK]**
- 6 **[↕]**: "Yes" → **[OK]** → **[📞]**

Baby monitor sensitivity

You can adjust the sensitivity of the baby monitor. Increase or decrease the sensitivity to adjust the sound level needed to trigger the baby monitor feature.

- This feature cannot be set during a monitoring call.
- 1 Press **[*]** on the handset being monitored.
 - 2 **[↕]**: "Sensitivity Level" → **[OK]**
 - 3 **[↕]**: Select the desired setting. → **[OK]** → **[📞]**

Answering the baby monitor

■ When monitoring with a handset:

Press **[📞/📞]** to answer calls.

If you want to respond from the monitoring handset, press **[📞]**.

- The monitoring handset will answer calls automatically when the auto intercom feature is set to "On".

Note:

- If you receive an outside call when communicating with the monitored handset, the interrupt tone sounds. To answer the call, press **[📞]**, then press **[📞/📞]**.

■ When monitoring from an outside line:

Answer the call.

If you want to respond from the monitoring phone, press **[#][1]** using tone dialling.

You can turn off the baby monitor feature by pressing **[#][0]**.

Note:

- The unit disconnects the call automatically after 2 minutes.

Other programming

Changing the handset name

The default handset name is "Handset 1". You can customise the name of each handset ("Bob", "Kitchen", etc.). To display the handset name in standby mode, turn on the handset name display feature (page 42).

- 1 **[*][#][1][0][4]**

Programming

- 2 Enter the desired name (10 characters max.).
- 3 [OK] → [📞]

Displaying the handset name

You can select whether or not the handset name is displayed in standby mode. The default setting is “off”.

- 1 [☰]#105
- 2 [↕]: Select the desired setting. → [OK] → [📞]

Call restriction

You can restrict the handset from dialling certain numbers. You can assign up to 6 phone numbers to be restricted. Storing area codes here prevents the handset from dialling any phone number in that area code.

- 1 [☰]#256
- 2 Enter the base unit PIN (default: “0000”).
 - If you forget your PIN, contact an authorised service centre.
- 3 [✓]
 - “✓” is displayed next to the selected handset numbers.
 - To cancel the handset: Press [✓] again. “✓” disappears.
- 4 [OK]
- 5 [↕]: Select a memory location. → [OK]
- 6 Enter the phone number or area code to be restricted (8 digits max.). → [OK] → [📞]

Enhancing security for phone calls

You can increase the security of phone conversations by setting this feature to “Enhanced”. When “Enhanced” is selected,  is displayed. The default setting is “Normal”.

- 1 [☰]#729
- 2 [↕]: Selected the desired setting. → [OK]
- 3 [📞]

Note:

- When enhanced security is enabled, sound may cut in and out during conversations.

Changing the base unit PIN

Important:

- If you change the PIN (Personal Identification Number), please make note of your new PIN. The unit will not reveal the PIN to you. If you forget your PIN, contact an authorised service centre.

- 1 [☰]#132
- 2 Enter the current 4-digit base unit PIN (default: “0000”).
- 3 Enter the new 4-digit base unit PIN. → [OK]
- 4 [↕]: “Yes” → [OK] → [📞]

Storing an area code to be deleted automatically

In some situations, phone numbers stored automatically in the caller list (page 45) will include area codes. If you do not want to dial the area code when making calls from the caller list,

you can store the area code which you want the unit to delete automatically.

Example: You have stored the area code "123". If you make a call from the caller list to the phone number "123-456-7890", the unit dials "456-7890".

- 1 **[]#255**
- 2 Enter an area code (5 digits max.).
→ **[OK]** → **[]**

Using Caller ID service

Important:

- This unit is Caller ID compatible. To use Caller ID features, you must subscribe to a Caller ID service. Contact your phone service provider for details.



Caller ID features

When an outside call is being received, the caller information is displayed. Caller information for the last 50 callers is logged in the caller list from the most recent call to the oldest.



- If the unit cannot receive caller information, the following is displayed:
 - **“Out of Area”**: The caller dials from an area which does not provide a Caller ID service.
 - **“Private Caller”**: The caller requests not to send caller information.
- If the unit is connected to a PBX system, caller information may not be properly received. Contact your PBX supplier.

Missed calls

If a call is not answered, the unit treats it as a missed call and  is displayed. This lets you know if you should view the caller list to see who called while you were away.

Even if only one missed call in the caller list is viewed (page 45),  disappears from the display. When you receive another new call,  is displayed again.

Note:

- Even when there are unviewed missed calls,  disappears from the standby display if the following operation is performed by the handset:
 - Being replaced on the base unit.
 - Pressing [].

Phonebook name display

When caller information is received and it matches a phone number stored in the phonebook, the stored name in the phonebook is displayed and logged in the caller list.

However, if the caller information matches a number in the Favourites Key, the stored name in the Favourites Key is displayed, but it will not be shown in the caller log.

Talking Caller ID

This feature lets you know who is calling without looking at the display.

To use this feature, you must:

- subscribe to a Caller ID service of your phone service provider.
- turn this feature on (page 35).
- store the name and phone number in the phonebook (page 28) or the Favourites Key (page 30).

Phonebook name announcement

When caller information is received from your phone service provider and if it matches a phone number stored in either the phonebook or the Favourites Key, the corresponding stored name will be announced following every ring. If that phone number has not been stored in the phonebook or Favourites Key, the caller information is announced.

Note:

- Name pronunciation may vary. This feature may not pronounce all names correctly.

Caller list

Important:

- Make sure the unit's date and time setting is correct (page 15).

Viewing the caller list and calling back

- 1 Press left **[●]** navigator key.
 - Or press **[↵]** (left soft key).
If the redial list is displayed, press left **[●]** navigator key to switch to the caller list.
- 2 Press **[▼]** to search from the most recent call, or press **[▲]** to search from the oldest call.
- 3 To call back, press **[📞]**.
To exit, press **[⏻]**.

Note:

- If **[▶]** is displayed in step 2, not all of the information is shown. To see the remaining information, press **[▶]**. To return to the previous screen, press **[◀]**.
- If the entry has already been viewed or answered, "✓" is displayed.
 - "📞" indicates the caller blocked by Nuisance call block.
 - "📞" indicates the caller blocked by Automated call block.
- If you do not want to dial the area code when making calls from the caller list, you can store the area code which you want the unit to delete automatically (page 42).

Editing a caller's phone number

- 1 Press left **[●]** navigator key.
 - Or press **[↵]** (left soft key).
If the redial list is displayed, press left **[●]** navigator key to switch to the caller list.
- 2 **[↕]**: Select the desired entry. → **[⏻]**
- 3 **[↕]**: "Edit & Call" → **[OK]**
- 4 Edit the number.
- 5 **[📞]**

Erasing selected caller information

- 1 Press left **[●]** navigator key.
 - Or press **[↵]** (left soft key).
If the redial list is displayed, press left **[●]** navigator key to switch to the caller list.
- 2 **[↕]**: Select the desired entry.
- 3 **[X]** → **[↕]**: "Yes" → **[OK]** → **[⏻]**

Erasing all caller information



- 1 Press left **[●]** navigator key.
 - Or press **[↵]** (left soft key).
If the redial list is displayed, press left **[●]** navigator key to switch to the caller list.
- 2 **[X]** → **[↕]**: "Yes" → **[OK]** → **[⏻]**

Voicemail service

Voicemail is an answering service that may be offered by your phone service provider. This service can also record calls when you are unavailable to answer the phone or when your line is busy. Messages are recorded on the phone company system.







When you have new messages,  is displayed on the handset if message indication service is available. Please contact your phone service provider for details of this service.

Important:

- If  still remains on the display even after you have listened to new messages, turn it off by pressing and holding  for 3 seconds.

Character entry

The dial keys are used to enter characters and numbers. Each dial key has multiple characters assigned to it. The characters that can be entered depend on the character entry mode (page 46).

- Press  or  to move the cursor left or right.
- Press dial keys to enter characters and numbers.
- Press  to erase the character or number highlighted by the cursor. Press and hold  to erase all characters or numbers.
- Press  (A→a) to switch between uppercase and lowercase.
- To enter another character located on the same dial key, press  to move the cursor to the next space, then press the appropriate dial key.
- If you do not press any dial key within 2 seconds after entering a character, the character is fixed and the cursor moves to the next space.

Character entry modes

The available character entry modes are Alphabet (ABC), Numeric (0-9), Greek (ΑΒΓ), Extended 1 (ĂĂĂ), Extended 2 (ŠŠŠ), and Cyrillic (АБВ). When in these entry modes except Numeric, you can select which character is entered by pressing a dial key repeatedly.

When the unit displays the character entry screen:

 → : Select a character entry mode. → 

Note:

-  in the following tables represents a single space.

Alphabet character table (ABC)

0	1	2	3	4	5	6	7	8	9
_ 0	# & ' () * , - . / 1	A B C 2	D E F 3	G H I 4	J K L 5	M N O 6	P Q R S 7	T U V 8	W X Y Z 9
		a b c 2	d e f 3	g h i 4	j k l 5	m n o 6	p q r s 7	t u v 8	w x y z 9

Numeric entry table (0-9)

0	1	2	3	4	5	6	7	8	9
0	1	2	3	4	5	6	7	8	9

Greek character table (ΑΒΓ)

0	1	2	3	4	5	6	7	8	9
_ 0	# & ' () * , - . / 1	Α Β Γ 2	Δ Ε Ζ 3	Η Θ Ι 4	Κ Λ Μ 5	Ν Ξ Ο 6	Π Ρ Σ 7	Τ Υ Φ 8	Χ Ψ Ω 9

Extended 1 character table (ÄÅ)

0	1	2	3	4	5	6	7	8	9
_ 0	# & ' () * , - . / 1	A Ä Á Ä Ä Ä Å Æ B Ç 2	D E È É Ê Ë Ë F 3	G Ğ H I Ì Í Î Ï Ñ Ñ 4	J K L 5	M N Ñ O Ö Ó Ô Õ Ö ø 6	P Q R S Ş ß 7	T U Ù Ú Û Ü Û V 8	W Ŵ X Y ŷ Z 9
		a à á â ã ä å æ b ç 2	d e è é ê ë ë f 3	g ğ h i ì í î ï ñ ñ 4	j k l 5	m n ñ o ò ó ô õ ö ø 6	p q r s ş ß 7	t u ù ú û ü û v 8	w Ŵ x y ŷ z 9

- The following are used for both uppercase and lowercase: ø Ŵ ŷ

Useful Information

Extended 2 character table (ŠŠŠ)

0	1	2	3	4	5	6	7	8	9
0	# & ' () * , . / 1	A Á Â Ã Ä Å Ā Ą Ć Ĉ Ċ Č Ď ě	D Ď E É Ę Ě F 3	G H I Í 4	J K L Ł Ĺ 5	M N Ń Ň Ō Ó Ö 6	P Q R Ŕ Ŗ Š 7	T Ť U Ú Ů ů 8	W X Y ŷ Ź Ž 9
		a á â ã ä å Ā ā Ć ć Ĉ ĉ Č č Ď ě f 3	d ě e é ě ě 4	g h i í 4	j k l ł ł 5	m n Ń Ń ō ó ö 6	p q r r ŕ ř š š 7	t ť u ú ů ů 8	w x y y ŷ ž ž 9

- The following are used for both uppercase and lowercase:

Ą Ć Ĉ Ċ Ę Ł Ĺ Ń Ŕ Ś Š ů ŷ Ź Ž Ž

Cyrillic character table (АБВ)

0	1	2	3	4	5	6	7	8	9
0 1 2 3 4 5 6 7 8 9	# & ' () * , . / 1	А Б В Г 2	Д Е Ж З 3	И Й К Л 4	М Н О П 5	Р С Т У 6	Ф Х Ц Ч 7	Ш Щ Ъ Ы Я 8	Ь Э Ю 9

Error messages

Display message	Cause/solution
Base no power or No link. Reconnect AC adaptor.	<ul style="list-style-type: none"> Confirm the base unit's AC adaptor is connected to the unit and the power outlet correctly. The handset has lost communication with the base unit. Move closer to the base unit and try again. Unplug the base unit's AC adaptor to reset the unit. Reconnect the adaptor and try again. The handset's registration may have been cancelled. Re-register the handset (page 54).
Check Phone Line	<ul style="list-style-type: none"> Make sure that you are using the supplied telephone line cord. The telephone line cord has not been connected yet or not connected properly. Check the connections (page 10).

Display message	Cause/solution
Checking	<ul style="list-style-type: none"> The automated call block function is in operation. Try again later.
Memory Full	<ul style="list-style-type: none"> The phonebook memory is full. Erase unwanted entries (page 29). The call block list memory is full. Erase unwanted entries (page 23).
Use rechargeable battery.	<ul style="list-style-type: none"> A wrong type of battery such as alkaline or manganese was inserted. Use only the rechargeable Ni-MH batteries noted on page 3, 6.
You must first subscribe to Caller ID.	<ul style="list-style-type: none"> You must subscribe to a Caller ID service. Once you receive caller information after subscribing to a Caller ID service, this message will not be displayed.

Troubleshooting

If you still have difficulties after following the instructions in this section, disconnect the base unit's AC adaptor and turn off the handset, then reconnect the base unit's AC adaptor and turn on the handset.

General use

Problem	Cause/solution
The handset does not turn on even after installing charged batteries.	<ul style="list-style-type: none"> Place the handset on the base unit to turn on the handset.
The unit does not work.	<ul style="list-style-type: none"> Make sure the batteries are installed correctly (page 10). Fully charge the batteries (page 11). Check the connections (page 10). Unplug the base unit's AC adaptor to reset the unit and turn off the handset. Reconnect the adaptor, turn on the handset and try again. The handset has not been registered to the base unit. Register the handset (page 54).
The handset display is blank.	<ul style="list-style-type: none"> The handset is not turned on. Turn the power on (page 15).



Useful Information

Problem	Cause/solution
I cannot hear a dial tone.	<ul style="list-style-type: none">● Make sure that you are using the supplied telephone line cord. Your old telephone line cord may have a different wiring configuration.● The base unit's AC adaptor or telephone line cord is not connected. Check the connections.● Disconnect the base unit from the telephone line and connect the line to a known working telephone. If the working telephone operates properly, contact our service personnel to have the unit repaired. If the working telephone does not operate properly, contact your phone service provider.
Error sound is heard when I press some keys on base unit.	<ul style="list-style-type: none">● Automated call block is being screened. Try again later.
I cannot use the intercom feature.	<ul style="list-style-type: none">● This feature is available between the handsets. Although the handset displays "Intercom" or "Auto Intercom", these features are not available for this model.
The unit does not emit the specified number of rings.	<ul style="list-style-type: none">● If the first ring is turned off, the number of rings decreases by 1 from the specified number of rings (page 33).
Handset functions abnormally, such as: <ul style="list-style-type: none">● One-sided connection (only one party can hear the other).● No ring when receiving calls.● Complete inability to connect calls.	<ul style="list-style-type: none">● This could be due to temporary communication errors between the phone and the router/FritzBox.● Please reboot your router/FritzBox by unplugging it from the AC outlet, waiting for 10 seconds, and then plugging it back in. This may fix the problems.

Menu list

Problem	Cause/solution
I cannot register a handset to a base unit.	<ul style="list-style-type: none">● You entered the wrong PIN. If you forget your PIN, contact an authorised service centre.
I cannot remember the key lock mode password.	<ul style="list-style-type: none">● If you forget your password, enter ✖ 7 0 0 0 instead of your key lock password.

Battery recharge

Problem	Cause/solution
The handset beeps and/or  flashes.	<ul style="list-style-type: none"> ● Battery charge is low. Fully charge the batteries (page 11).
I fully charged the batteries, but <ul style="list-style-type: none"> –  still flashes or – the operating time seems to be shorter. 	<ul style="list-style-type: none"> ● Clean the battery ends (\oplus, \ominus) and the charge contacts with a dry cloth and charge again. ● It is time to replace the batteries (page 10).

Making/answering calls

Problem	Cause/solution
 is displayed.	<ul style="list-style-type: none"> ● The handset is too far from the base unit. Move closer. ● The base unit's AC adaptor is not properly connected. Reconnect AC adaptor to the base unit. ● The handset is not registered to the base unit. Register it (page 54). ● Activating eco mode reduces the range of the base unit in standby mode. If required, turn eco mode off (page 15).
Noise is heard, sound cuts in and out.	<ul style="list-style-type: none"> ● You are using the handset or base unit in an area with high electrical interference. Re-position the base unit and use the handset away from sources of interference. ● Move closer to the base unit. ● If you use a DSL/ADSL service, we recommend connecting a DSL/ADSL filter between the base unit and the telephone line jack. Contact your DSL/ADSL provider for details.
Sound quality seems to be getting worse.	<ul style="list-style-type: none"> ● You have registered a handset that is not recommended. The clearest sound quality is only possible by registering the provided handset.
The handset does not ring.	<ul style="list-style-type: none"> ● The ringer volume is turned off. Adjust ringer volume (page 18, 34). ● Do not disturb mode is turned on. Turn it off (page 39).

Useful Information

Problem	Cause/solution
I cannot make a call.	<ul style="list-style-type: none">• The dialling mode may be set incorrectly. Change the setting (page 16).• You dialled a call restricted number (page 42).• The key lock feature is turned on. Turn it off (page 20).
I cannot use voice paging.	<ul style="list-style-type: none">• You cannot use voice paging if other units are in use.
I cannot hear other party's voice clearly during a conversation.	<ul style="list-style-type: none">• Press either [▲] on the navigator key, or [⊕] located on the side of the handset repeatedly, to select the desired volume while talking.• Turn on the Amplify key feature by pressing [👉] while on a call (page 19). Note that volume will be increased substantially.

Favourites Key

Problem	Cause/solution
The Favourites Key remains flashing.	<ul style="list-style-type: none">• The Favourites Key flashes when there is a missed call from any of your favourite contacts is received and not answered.
No notification of missed call from favourite contacts.	<ul style="list-style-type: none">• When there is a missed call from the favourites contact, the Favourites Key flashes at 5 second intervals. Press the Favourites Key, if "→]" is displayed besides the favourite contacts that means you had a missed call from that contact. <p>Note: Once you press the Favourites Key to see the missed call and press [🔇], the Favourites Key will stop flashing.</p>

Caller ID, Talking Caller ID

Problem	Cause/solution
Caller information is not displayed.	<ul style="list-style-type: none"> ● You must subscribe to a Caller ID service. Contact your phone service provider for details. ● If your unit is connected to any additional telephone equipment, remove and plug the unit directly into the wall jack. ● If you use a DSL/ADSL service, we recommend connecting a DSL/ADSL filter between the base unit and the telephone line jack. Contact your DSL/ADSL provider for details. ● Other telephone equipment may be interfering with this unit. Disconnect the other equipment and try again.
Caller information is displayed or announced late.	<ul style="list-style-type: none"> ● Depending on your phone service provider, the unit may display the caller's information at the 2nd ring or later. Set the first ring to "OFF" (page 33). ● Move closer to the base unit.
Caller information is not announced.	<ul style="list-style-type: none"> ● To use the Talking Caller ID feature, store the name and phone number in the phonebook (page 28) or Favourites Key (page 30). ● The handset ringer volume is turned off. Adjust it (page 18, 34). ● The Talking Caller ID feature is turned off. Turn it on (page 35).
Time on the unit has shifted.	<ul style="list-style-type: none"> ● Incorrect time information from incoming Caller ID changes the time. Set the time adjustment to "Manual" (off) (page 34).
The name stored in the phonebook is not fully displayed while an outside call is being received.	<ul style="list-style-type: none"> ● Edit the phonebook entry name to fit in 1 line of text (page 29).

Useful Information

Problem	Cause/solution
The following features are not available: <ul style="list-style-type: none">● Phonebook.● CLIP (Caller Line Identification Presentation).● Date and time display (not available or incorrect).	<ul style="list-style-type: none">● If the handset is directly registered to the router/FritzBox, these features may not be available.● Connect the base unit to an analog port on the router/FritzBox, and then register the handset to the base unit.● If connecting the base unit to the router/FritzBox is not feasible, please refer to the manual of the router/FritzBox or contact the manufacturer for potential workarounds or alternative solutions.

Liquid damage

Problem	Cause/solution
Liquid or other form of moisture has entered the handset/base unit.	<ul style="list-style-type: none">● Disconnect the AC adaptor and telephone line cord from the base unit. Remove the batteries from the handset and leave to dry for at least 3 days. After the handset/base unit are completely dry, reconnect the AC adaptor and telephone line cord. Insert the batteries and charge fully before use. If the unit does not work properly, contact an authorised service centre.

Caution:

- To avoid permanent damage, do not use a microwave oven to speed up the drying process.

Registering a unit

Registering a handset to the base unit

The supplied handset and base unit are pre-registered. If for some reason the handset is not registered to the base unit (for example,  is displayed even when the handset is near the base unit), re-register the handset.

1 Handset:

 # 1 3 0

2 Base unit:

Press and hold  for about 5 seconds.

3 Handset:

[OK] → Wait until “**Base PIN**” is displayed. → Enter the base unit PIN (default: “0000”). → **[OK]**

- If you forget your PIN, contact an authorised service centre.
-

Deregistering a handset

A handset can cancel its own registration to the base unit. This allows the handset to end its wireless connection with the system.

1 [☰] # 1 3 1

2 [OK]

3 [↕]: “Yes” → [OK] → [🔌]

Index

- A** Alarm: 38
 - Answering calls: 18
 - Area code: 42
 - Auto talk: 18, 36
 - Automated call block: 25
- B** Baby monitor: 39
 - Battery: 10, 12
- C** Call restriction: 42
 - Call waiting: 18
 - Call Waiting Caller ID: 18
 - Caller ID service: 44
 - Caller list: 45
 - Caller list edit: 45
 - Category: 28
 - Chain dial: 29
 - Character entry: 46
 - Control type: 13
- D** Date and time: 15
 - Dialling mode: 16
 - Direct command code: 32
 - Display
 - Contrast: 36
 - Do not disturb mode: 38
- E** Eco mode: 15
 - Equalizer: 20
 - Error messages: 48
- F** Favourites Key: 30
- H** Handset
 - Deregistration: 55
 - Name: 41
 - Registration: 54
 - Hold: 18
- K** Key lock: 20
- Keytones: 36
- L** Low battery alert: 16
- M** Making calls: 17
 - Missed calls: 44
 - Mute: 18
- N** Noise reduction: 19
 - Nuisance call block: 22
- P** Pause: 17
 - Phonebook: 28
 - PIN: 42
 - Power failure: 11
 - Power on/off: 15
 - Privacy mode: 36
- R** Recall/flash: 18
 - Redialling: 17
 - Ringer indicator: 16
 - Ringer tone
 - Intercom call: 34
 - Outside call: 34
- S** Security for phone calls: 42
 - Speakerphone: 17
 - Speed dial: 29
- T** Talking Caller ID: 44
 - Temporary tone dialling: 19
 - Time adjustment: 34
 - Torchlight: 16
 - Troubleshooting: 49
- V** Voicemail: 46
 - Volume
 - Amplify key: 19
 - Receiver: 17
 - Ringer for intercom call (Handset): 34
 - Ringer for outside call (Handset): 18, 34
 - Speaker: 17

For your future reference

We recommend keeping a record of the following information to assist with any repair under warranty.

Serial No.	Date of purchase
(found on the bottom of the base unit)	
Name and address of dealer	

Panasonic Entertainment & Communication Co., Ltd.

1-10-12 Yagumo-higashi-machi, Moriguchi City, Osaka 570-0021, Japan

<http://www.panasonic.com>

© Panasonic Entertainment & Communication Co., Ltd. 2024

PNQP1954ZA PP0624MH0