

# Panasonic®

## Basic Operating Instructions

### Digital Camera

Model No. **DMC-FZ70**

LUMIX

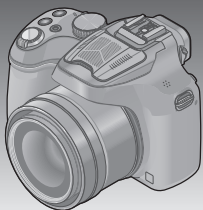

Please read these instructions carefully before using this product, and save this manual for future use.



More detailed instructions on the operation of this camera are contained in “Operating Instructions for advanced features (PDF format)” in the supplied CD-ROM. Install it on your PC to read it.



## Dear Customer,

We would like to take this opportunity to thank you for purchasing this Panasonic Digital Camera. Please read these Operating Instructions carefully and keep them handy for future reference. Please note that the actual controls and components, menu items, etc. of your Digital Camera may look somewhat different from those shown in the illustrations in these Operating Instructions.

### Carefully observe copyright laws.

- Recording of pre-recorded tapes or discs or other published or broadcast material for purposes other than your own private use may infringe copyright laws. Even for the purpose of private use, recording of certain material may be restricted.

## Information for Your Safety

### **WARNING:**

To reduce the risk of fire, electric shock or product damage,

- Do not expose this unit to rain, moisture, dripping or splashing.
- Use only the recommended accessories.
- Do not remove covers.
- Do not repair this unit by yourself. Refer servicing to qualified service personnel.

The socket outlet shall be installed near the equipment and shall be easily accessible.

### ■ Product identification marking

Product	Location
Digital camera	Bottom
Battery charger	Bottom

## ■ About the battery pack

### **CAUTION**

- Danger of explosion if battery is incorrectly replaced. Replace only with the type recommended by the manufacturer.
  - When disposing the batteries, please contact your local authorities or dealer and ask for the correct method of disposal.
- 
- Do not heat or expose to flame.
  - Do not leave the battery(ies) in a car exposed to direct sunlight for a long period of time with doors and windows closed.

### **Warning**

Risk of fire, explosion and burns. Do not disassemble, heat above 60 °C or incinerate.

## ■ About the battery charger

### **CAUTION!**

**To reduce the risk of fire, electric shock or product damage,**

- **Do not install or place this unit in a bookcase, built-in cabinet or in another confined space. Ensure this unit is well ventilated.**
- 
- The battery charger is in the standby condition when the AC power supply cord is connected. The primary circuit is always “live” as long as the power cord is connected to an electrical outlet.

## ■ Cautions for Use

- When using an AC adaptor, use the AC cable supplied with the AC adaptor.
- Do not use any other USB connection cables except the supplied one or a genuine Panasonic USB connection cable (DMW-USBC1: optional).
- Use a "High Speed HDMI mini cable" with the HDMI logo.  
Cables that do not comply with the HDMI standards will not work.  
"High Speed HDMI mini cable" (Type C-Type A plug, up to 3 m long)
- Always use a genuine Panasonic AV cable (DMW-AVC1: optional).

### **Keep this unit as far away as possible from electromagnetic equipment (such as microwave ovens, TVs, video games etc.).**

- If you use this unit on top of or near a TV, the pictures and/or sound on this unit may be disrupted by electromagnetic wave radiation.
- Do not use this unit near cell phones because doing so may result in noise adversely affecting the pictures and/or sound.
- Recorded data may be damaged, or pictures may be distorted, by strong magnetic fields created by speakers or large motors.
- Electromagnetic wave radiation generated by microprocessors may adversely affect this unit, disturbing the pictures and/or sound.
- If this unit is adversely affected by electromagnetic equipment and stops functioning properly, turn this unit off and remove the battery or disconnect AC adaptor (DMW-AC8G: optional). Then reinsert the battery or reconnect AC adaptor and turn this unit on.

### **Do not use this unit near radio transmitters or high-voltage lines.**

- If you record near radio transmitters or high-voltage lines, the recorded pictures and/or sound may be adversely affected.

### **-If you see this symbol-**



#### **Information on Disposal in other Countries outside the European Union**

This symbol is only valid in the European Union. If you wish to discard this product, please contact your local authorities or dealer and ask for the correct method of disposal.

## Contents

---

Information for Your Safety ....	2	Taking Pictures with	
Care of the camera .....	6	different picture effects	
Standard accessories .....	7	[Creative Control] Mode.....	17
Names and Functions of		Using the rear dial .....	18
Main Parts .....	8	Setting the menu .....	19
Attaching the lens cap/ shoulder strap.....	10	Reading the Operating	
Charging the battery .....	11	Instructions (PDF format) .....	20
Inserting and removing the		Keeping the pictures on	
card (optional)/the battery ....	12	your PC.....	21
Sequence of operations.....	13	Specifications .....	23
Taking pictures with		Limited Warranty	
automatic settings		(ONLY FOR AUSTRALIA) .....	26
[Intelligent Auto] Mode.....	15		

## Care of the camera

### ■ Camera handling



**Keep the camera away from excessive vibration, force, or pressure.**

- Avoid using the camera under the following conditions, which may damage the lens, LCD monitor, viewfinder, or camera body. This may also cause the camera to malfunction or prevent recording.

- Dropping or hitting the camera against a hard surface
- Pushing with excessive force on the lens, LCD monitor, or viewfinder



- **When camera is not in use or when using the playback feature, ensure that the lens is in the stored position, with lens cap on.**

- **There are times when rattling sounds or vibrations will come from the camera, but these are due to the motion of the aperture, the zoom and the motor and do not indicate a defect.**



**The camera is not dust resistant, splash resistant, or waterproof.**

**Avoid using the camera in places with excessive dust or sand, or where water can come into contact with the camera.**

- Avoid using the camera under the following conditions, which present a risk that sand, water, or foreign material may enter the camera through the lens or openings around buttons. Be especially careful because these conditions may damage the camera, and such damage may not be repairable.







- In extremely dusty or sandy places
- In the rain or by the shore, where the camera may be exposed to water

### ■ Condensation (When the lens, the LCD monitor, or viewfinder, is fogged up)

- Condensation may occur when the camera is exposed to sudden changes of temperature or humidity. Avoid these conditions, which may make the lens, LCD monitor, or viewfinder, dirty, cause mould, or damage the camera.
- If condensation does occur, turn off the camera and wait about two hours before using it. Once the camera adjusts to the surrounding temperature, the fogging will clear naturally.

## Standard accessories

Check that all the accessories are supplied before using the camera. Part numbers are as of July 2013. These may be subject to change.



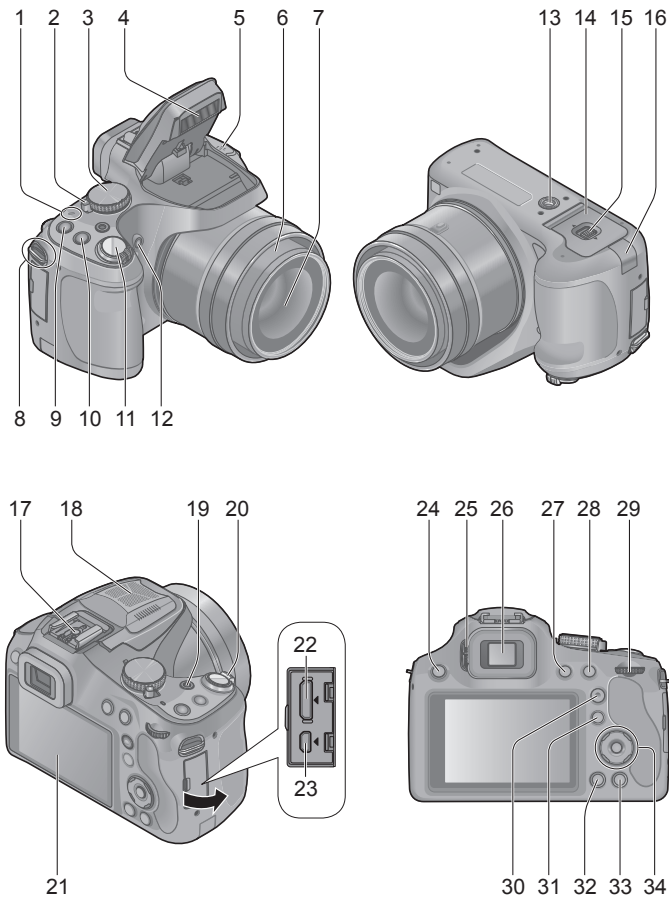

<input type="checkbox"/> <b>Battery pack</b> DMW-BMB9E • Charge the battery before use. Battery pack is indicated as battery pack or battery in the text.		<input type="checkbox"/> <b>USB connection cable</b> K1HY08YY0031	
<input type="checkbox"/> <b>Battery Charger</b> DE-A84A  Battery charger is indicated as battery charger or charger in the text.		<input type="checkbox"/> <b>Lens Cap/ Lens Cap String</b> VYQ8752	
<input type="checkbox"/> <b>AC cable</b> K2CJ2YY00052		<input type="checkbox"/> <b>CD-ROM</b> VFF1235 • Software: Use it to install the software on your PC. • Operating Instructions for advanced features	
<input type="checkbox"/> <b>Shoulder Strap</b> VFC4453			

- SD Memory Card, SDHC Memory Card and SDXC Memory Card are indicated as card in the text.
- **Cards are optional. You can record or play back pictures on the built-in memory when you are not using a card.**
- Consult the dealer or your nearest Service Centre if you lose the supplied accessories. (You can purchase the accessories separately.)
- Please dispose of all packaging appropriately.
- Keep small parts in a safe place out of the reach of children.
- The illustrations and screens in this manual may differ from the actual product.
- A lens hood is not supplied with this unit.
- **SILKPIX Developer Studio is not provided on the supplied CD-ROM. Download this software from the website and install it on your computer to use. (→22)**

## Names and Functions of Main Parts





- 1 Power lamp
- 2 Camera [ON/OFF] switch
- 3 Mode dial
- 4 Flash
- 5 Speaker
  - Be careful not to cover the speaker with your finger. Doing so may make sound difficult to hear.
- 6 Lens barrel
- 7 Lens
- 8 Shoulder strap eyelet
- 9 [FOCUS] button
- 10 [] (Burst Mode) button
- 11 Shutter button
- 12 Self-timer indicator/  
AF Assist Lamp
- 13 Tripod mount
  - Do not attach to a tripod with a 5.5 mm or longer screw. Doing so may damage this unit.
- 14 Card/Battery door
- 15 Release lever
- 16 DC coupler cover
  - When using an AC adaptor, ensure that the Panasonic DC coupler (DMW-DCC6: optional) and AC adaptor (DMW-AC8G: optional) are used.
  - Always use a genuine Panasonic AC adaptor (DMW-AC8G: optional).
- 17 Hot shoe
  - Do not attach other than the external flash on the hot shoe.
- 18 Stereo microphone
- 19 Motion picture button
- 20 Zoom lever
- 21 LCD monitor
- 22 [HDMI] socket
- 23 [AV OUT/DIGITAL] socket
- 24 [] (Flash open) button
- 25 Diopter adjustment dial
- 26 Viewfinder ([LVF])
  - In this manual, “viewfinder” is used to indicate the LVF.
- 27 [LVF] button
- 28 [AF/AE LOCK (Fn1)] button
- 29 Rear dial
- 30 [AF/AF-LOCK/MF] button
- 31 [] (Playback) button
  - Use this to select the recording mode or playback mode.
- 32 [DISP.] button
- 33 [] (Delete/Cancel/Quick menu) button
- 34 Cursor button / [MENU/SET] button
  - In this manual, the button that is to be used is indicated by .

## Attaching the lens cap/shoulder strap

### ■ Attaching the Lens Cap

- When you turn the camera off or carry the camera, attach the lens cap to protect the surface of the lens.

#### 1 Pass the string through the hole on the camera

#### 2 Pass the same string through the hole on the lens cap

- Pass the lens cap through the loop of the string and tighten it.

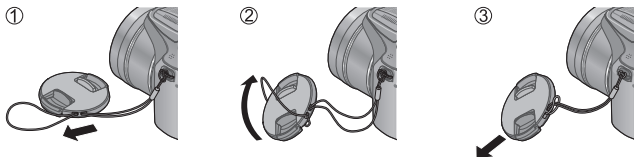

#### 3 Attach the lens cap

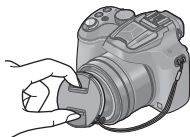

### ■ Attaching the Shoulder Strap

- We recommend attaching the shoulder strap when using the camera to prevent it from dropping.

#### 1 Pass the shoulder strap through the hole at the shoulder strap eyelet

- Attach the shoulder strap so that the "LUMIX" Logo is on the outside.

#### 2 Pass the shoulder strap through the stopper and fasten the shoulder strap

- Ⓐ Pull the shoulder strap 2 cm or more.

- Attach the shoulder strap to the other side of the camera being careful not to twist it.

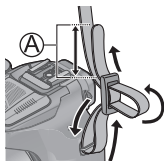

- Make sure that the shoulder strap does not come loose.

## Charging the battery

- Use the dedicated charger and battery.
- The battery is not charged when the camera is shipped. Charge the battery before use.
- We recommend charging in a location where the ambient temperature is between 10 °C and 30 °C.

### 1 Insert the battery terminals and attach the battery to the charger

Ensure [LUMIX] faces outwards.

### 2 Connect the charger to the electrical outlet

#### Charging light ([CHARGE])

**On:** Charging in progress  
(approx. 155 min. if fully depleted)

**Off:** Charging complete

#### If light is flashing:

- Charging may take longer than normal if battery temperature is too high or too low (charging may not be completed).
- Battery/charger connector is dirty. Clean with a dry cloth.

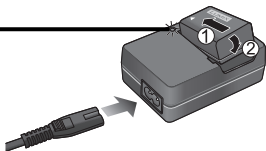

- The battery becomes warm after using it and during and after charging. The camera also becomes warm during use. This is not a malfunction.
- You cannot charge the battery of this unit using a USB connection cable.

#### ■ About batteries that you can use with this unit

The battery that can be used with this unit is DMW-BMB9E.

## Inserting and removing the card (optional)/ the battery

- Turn this unit off and confirm that the lens barrel is retracted.

**1** Slide the release lever to the [OPEN] position and open the card/battery door

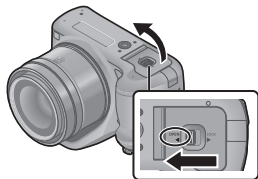

**2** **Battery:**  
Being careful about the battery orientation, insert all the way and then check that it is locked by lever

- Pull the lever in the direction of the arrow to remove the battery.

**Card:**  
Push it securely all the way until you hear a “click” while being careful about the direction in which you insert it

- To remove the card, push the card until it clicks, then pull the card out upright.

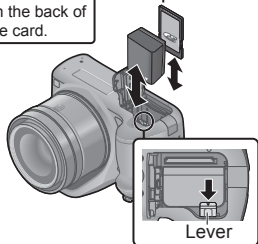
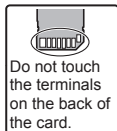

**3** Close the card/battery door and slide the release lever to the [LOCK] position

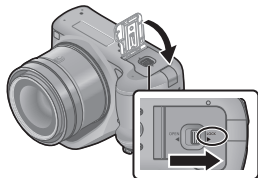

- Always use genuine Panasonic batteries (DMW-BMB9E).
- If you use other batteries, we cannot guarantee the quality of this product.
- Keep the Memory Card out of reach of children to prevent swallowing.
- We recommend using a Panasonic card.

## Sequence of operations

Before using the camera, remove the lens cap.

### 1 Turn the camera on (A)

- The clock is not set when the camera is shipped. Set the date and time before using the camera.

### 2 Set to the desired recording mode

Rotate the mode dial slowly to select the desired mode.

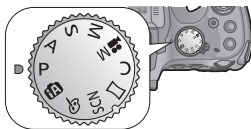

### ■ Recording mode

<b>iA</b>	Take pictures with automatic settings.
<b>P</b>	Take pictures with automatic shutter speed and aperture value settings.
<b>A</b>	Determine aperture, then record pictures.
<b>S</b>	Determine shutter speed, then record pictures.
<b>M</b>	Determine aperture and shutter speed, then record pictures.
<b>M</b> (with video icon)	Record motion picture with manual settings.
<b>C</b>	Record pictures using pre-registered settings.
<b>□</b>	Record panorama pictures.
<b>SCN</b>	Take pictures using Scene modes.
<b>👉</b>	Take pictures by selecting your preferred picture effect.

### 3 Take pictures

#### ■ Taking still pictures (Shutter button)

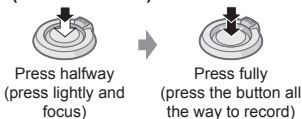

#### ■ Recording motion pictures (Motion picture button)



#### ■ Use the zoom lever to adjust the range of the picture to be captured

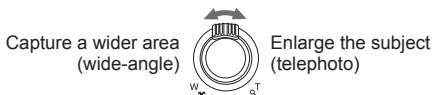

#### ■ Viewing your Pictures

① Press the Playback button (A)



② Press ◀▶ to select a picture to be displayed

- Ending Playback

Press the Playback button (A) or the motion picture button again, or press the shutter button halfway.

#### ■ Deleting Pictures

① Press [🗑️] (Q.MENU) button to delete the displayed picture

- A confirmation screen is displayed. When you select [Yes], the selected picture is deleted.

#### ■ About recording motion pictures

- You can continuously record a motion picture in [MP4] for up to 29 minutes 59 seconds or approx. 4 GB. (Since recording in [MP4] with [FHD] creates larger files, the recording time for such motion pictures will be shorter than 29 minutes 59 seconds.)
- You can record a motion picture to the built-in memory only in [MP4] using the [VGA] setting.

# Taking pictures with automatic settings

## [Intelligent Auto] Mode

The camera will set the most appropriate settings to match the subject and the recording conditions so we recommend this mode for beginners or those who want to leave the settings to the camera and take pictures easily.

### 1 Set to [iA] ([Intelligent Auto] Mode)

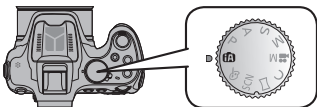

### 2 Take a picture

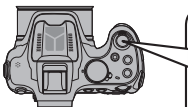

Press halfway  
(press lightly and focus)



Press fully  
(press the button all the way to record)



#### Focus display

(When focus is aligned: illuminated  
When focus is not aligned: flashing)

#### AF area

- The AF area is displayed around the subject's face by the Face Detection function. In other cases, it is displayed at the point on the subject which is in focus.

### ■ Defocusing the background

You can easily set the blurriness of the background while checking the screen.

### 1 Press the rear dial to display [ ]



### 2 Press ◀▶ or rotate the rear dial to adjust

- Press [ ] (Q.MENU) button to reset the setting to the default state (AUTO).
- To adjust automatically, reset the setting to the default state (AUTO).

### 3 Press [MENU/SET] or the rear dial to finalise the setting

### Recording using [Intelligent Auto Plus] Mode

When [Intelligent Auto Plus] (iA+) mode is selected, you can easily adjust the brightness and colouring, in addition to the background defocusing, without compromising the user-friendly operation of the [Intelligent Auto] Mode.

#### 1 Press [MENU/SET] when in [Intelligent Auto] Mode

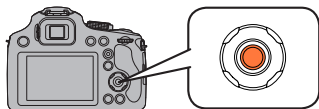

#### 2 Press $\blacktriangleright$ to select [iA+] and then press [MENU/SET]



### ■ Adjusting brightness, colouring, and background defocusing

#### 1 Press the rear dial to display the options

#### 2 Press $\blacktriangle$ $\blacktriangledown$ to select the item

- [ $\blacktriangle$ ]: Adjust the brightness.
- [ $\blacktriangledown$ ]: Adjust the background blur.
- [ $\blacksquare$ ]: Adjust the colour balance.



#### 3 Press $\blacktriangleleft$ $\blacktriangleright$ or rotate the rear dial to adjust

- Press [ $\blacksquare$ ] ( $\rightarrow$  Q.MENU) button to reset the setting to the default state (AUTO).
- To adjust automatically, reset the setting to the default state (AUTO).

#### 4 Press [MENU/SET] or the rear dial to set



# Taking Pictures with different picture effects

## [Creative Control] Mode

You can select your own settings from various effects and take pictures while confirming these effects on the LCD monitor.

### 1 Set mode dial to [📷]

### 2 Press ▲ ▼ to select an effect, and then press [MENU/SET]

- A brief description of selected picture effect appears when you press [DISP.] button.

Preview screen



### ■ Adjust the effect to fit your preferences

### 1 Press the rear dial to display the options

### 2 Press ▲ ▼ to select the item

- The items that can be adjusted differ depending on the selected picture effect.

[🔍]: Adjust the brightness.

[🌫️]: Adjust the background blur.

[🔧]: Adjust the setting conditions of the selected effect, etc.

### 3 Press ◀▶ or rotate the rear dial to adjust

- Press [🔄] (↶ Q.MENU) button to reset the setting to the default state (AUTO).
- To adjust automatically, reset the setting to the default state (AUTO).

### 4 Press [MENU/SET] or the rear dial to set

## Using the rear dial

You can use the rear dial to compensate the exposure or adjust the aperture value and shutter speed. The items that can be adjusted differ according to the recording mode.

### Compensating the exposure

- 1 Press the rear dial to set Exposure Compensation to a selected state

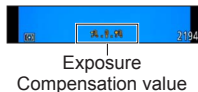
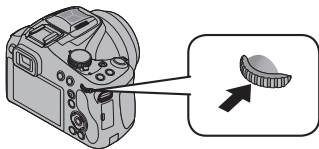

- 2 Rotate the rear dial to compensate the exposure

- If the picture is too dark, adjust the exposure to the “+” direction.
- If the picture is too bright, adjust the exposure to the “-” direction.

### Setting the aperture value/the shutter speed

- 1 Press the rear dial to select the items to set

- Items that can be set will switch every time the rear dial is pressed.

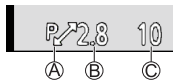

- (A) Programme Shift (Recording mode: P)
  - To adjust the setting, display the aperture value and shutter speed by pressing the shutter button halfway.
- (B) Aperture Value (Recording mode: A / M)
- (C) Shutter Speed (Recording mode: S / M)



- 2 Rotate the rear dial to set

## Setting the menu

Refer to the following procedures to operate the menus.

**Example: Setting [AF Mode] from  to  in the [Program AE] Mode**

- 1 Press [MENU/SET] to display the menu

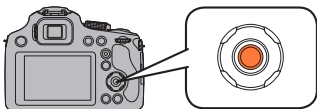

- 2 Press  $\blacktriangle$   $\blacktriangledown$  to select [AF Mode] and then press  $\blacktriangleright$

- Depending on the item, its setting may not appear or it may be displayed in a different way.

- 3 Press  $\blacktriangle$   $\blacktriangledown$  to select  and then press [MENU/SET] to set

- 4 Press [MENU/SET] to close the menu



### Switching to other menus

**Example: Switching to the [Setup] menu from [Rec] menu**

- 1 Press [MENU/SET] to display the menu
- 2 Press  $\blacktriangleleft$
- 3 Press  $\blacktriangledown$  to select the [Setup] menu icon 
- 4 Press  $\blacktriangleright$

- Select a menu item next and set it.



## Reading the Operating Instructions (PDF format)

More detailed instructions on the operation of this camera are contained in “Operating Instructions for advanced features (PDF format)” in the supplied CD-ROM. Install it on your PC to read it.

### ■ For Windows

- 1 Turn the PC on and insert the CD-ROM containing the Operating Instructions (supplied)
- 2 Click the [Operating Instructions]
- 3 Select the desired language and then click [Operating Instructions] to install  
Ⓐ To return to the install menu.
- 4 Double-click the “Operating Instructions” shortcut icon on the desktop

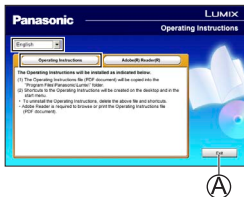

### ■ When the Operating Instructions (PDF format) will not open

You will need Adobe Acrobat Reader 5.0 or later, or Adobe Reader 7.0 or later to browse or print the Operating Instructions (PDF format).

- You can download and install a version of Adobe Reader that you can use with your OS from the following website.  
<http://get.adobe.com/reader/otherversions/>

### ■ For Mac

- 1 Turn the PC on and insert the CD-ROM containing the Operating Instructions (supplied)
- 2 Open the “Manual” folder in the CD-ROM and then copy the PDF file with the desired language inside the folder
- 3 Double click the PDF file to open it

# Keeping the pictures on your PC

## Installing supplied software

The supplied CD-ROM contains the following software.

Install the software on your computer to use.

For details about operating environment and usage, please read “Operating Instructions for advanced features” (PDF format) or the manuals for each software.

- PHOTOfunSTUDIO / LoiLoScope are not compatible with Mac.

PHOTOfunSTUDIO 9.2 AE	Pictures can be captured to a PC, and can be viewed, organised, printed, etc. Also, still pictures can be corrected and motion pictures can be edited. <ul style="list-style-type: none"><li>• Compatible OS: Windows 8 / 7 / Vista / XP</li></ul>
LoiLoScope (30-day full-trial version)	You can edit motion pictures easily. This will only install a shortcut to the trial version download site. For details about using LoiLoScope, please download and see the manual from the following site. <a href="http://loilo.tv/product/20/">http://loilo.tv/product/20/</a> <ul style="list-style-type: none"><li>• Compatible OS: Windows 8 / 7 / Vista / XP</li></ul>

### Preparations:

- Check your PC's specifications and operating environment for each software.
- Before inserting the CD-ROM (supplied), close all running applications.

### ■ For Windows

#### 1 Insert the supplied CD-ROM with the supplied software

- The installation menu runs.

#### 2 Click [Applications] on the install menu

#### 3 Click [Recommended Installation]

- Continue the installation procedure following the instructions displayed on the screen.

- The software compatible with your PC will be installed.

### Downloading SILKYPIX Developer Studio

This software develops and edits RAW file pictures. Edited pictures can be saved in a file format such as JPEG or TIFF that can be displayed on a PC, etc.

#### ■ Download procedure

Download SILKYPIX Developer Studio from the following site and install it on your computer to use. (This software is not provided on the supplied CD-ROM.)  
<http://www.isl.co.jp/SILKYPIX/english/p/>

- Compatible OS: Windows 8 / 7 / Vista / XP  
Mac OS X (10.4 - 10.8)
- For details on how to use the SILKYPIX Developer Studio, refer to the “Help” or the Ichikawa Soft Laboratory’s support website.
- To download the software, the unit must be connected to the Internet.
- It may take time to download the software in some communication environments.

### Copying still pictures and motion pictures

#### 1 Turn on the camera and a computer, and then connect the camera to the computer using the USB connection cable (supplied)

- Do not use any other USB connection cables except the supplied one or a genuine Panasonic USB connection cable (DMW-USBC1: optional). Doing so may cause damage to this unit.
- Check the plug direction and insert straight in. (If the cable is inserted in the wrong direction, the plug could become deformed and cause faulty operation)

#### 2 Press ▲ ▼ on the camera to select [PC], and press [MENU/SET]

#### 3 Copy the pictures to the computer

- For Windows  
Use “PHOTOfunSTUDIO” to copy pictures to your computer.
- For Mac  
Copy the picture files in the “DCIM” folder to your computer (except AVCHD motion pictures).

#### 4 Cancel the connection and disconnect the USB connection cable (supplied)

## Specifications

### Digital Camera: Information for your safety

<b>Power Source</b>	DC 8.4 V
<b>Power Consumption</b>	When recording with LCD Monitor: 1.6 W When recording with Viewfinder: 1.5 W When playing back with LCD Monitor: 1.0 W When playing back with Viewfinder: 0.7 W
<b>Camera effective pixels</b>	16,100,000 pixels
<b>Image sensor</b>	1/2.3" MOS sensor, total pixel number 16,800,000 pixels Primary colour filter
<b>Lens</b>	Optical 60 x zoom f=3.58 mm to 215 mm (35 mm film camera equivalent: 20 mm to 1200 mm)/ Max. Wide: F2.8 to F8.0 Max. Tele: F5.9 to F8.0
<b>Image Stabiliser</b>	Optical method
<b>Focus range</b>	
<b>AF</b>	30 cm (Max. Wide) / 1.5 m (Max. Tele) to $\infty$
<b>AF Macro / MF / Intelligent Auto / Motion picture</b>	1 cm (Max. Wide) / 1.5 m (Max. Tele) to $\infty$
<b>Scene Mode</b>	The focus ranges listed above may vary depending on the selected Scene Mode.
<b>Shutter system</b>	Electronic shutter + Mechanical shutter
<b>Minimum Illumination</b>	Approx. 9 lx (when i-Low light is used, the shutter speed is 1/25th of a second)
<b>Shutter speed</b>	8 seconds to 1/2000th of a second [Starry Sky] Mode: 15 seconds, 30 seconds, 60 seconds

## Specifications

<b>Exposure (AE)</b>	Programme AE (P) / Aperture-Priority AE (A) / Shutter-Priority AE (S) / Manual Exposure (M)
<b>Metering Mode</b>	[Multi Metering] / [Center Weighted] / [Spot]
<b>LCD monitor</b>	3.0" TFT LCD (3:2) (Approx. 460,800 dots) (field of view ratio about 100%)
<b>Viewfinder</b>	Colour LCD Viewfinder (Approx. 201,600 dots) (field of view ratio about 100%) (with diopter adjustment -4 to +4 diopter)
<b>Flash</b>	Built-in pop up flash
<b>Microphone</b>	Stereo
<b>Speaker</b>	Monaural
<b>Recording media</b>	Built-in Memory (Approx. 200 MB) / SD Memory Card / SDHC Memory Card / SDXC Memory Card
<b>Recording file format</b>	
<b>Still picture</b>	RAW / JPEG (based on Design rule for Camera File system, based on Exif 2.3 standard / DPOF corresponding) / MPO
<b>Motion pictures</b>	AVCHD / MP4
<b>Audio compression format</b>	AVCHD: Dolby® Digital (2 ch) MP4: AAC (2 ch)
<b>Interface</b>	
<b>Digital</b>	USB 2.0 (High Speed)
<b>Analogue video</b>	NTSC / PAL Composite (Switched by menu)
<b>Audio</b>	Audio line output (Monaural)
<b>Terminal</b>	HDMI: MiniHDMI Type C AV OUT/DIGITAL: Dedicated jack (8 pin)
<b>Dimensions</b>	Approx. 130.2 mm (W) x 97.0 mm (H) x 118.2 mm (D) (excluding the projection part)



<b>Mass</b>	With card and battery: Approx. 606 g Excluding card and battery: Approx. 562 g
<b>Operating temperature</b>	0 °C to 40 °C
<b>Operating humidity</b>	10%RH to 80%RH

### Battery Charger

(Panasonic DE-A84A): Information for your safety

<b>Input</b>	AC~ 110 V to 240 V, 50/60 Hz, 0.15 A
<b>Output</b>	DC--- 8.4 V, 0.43 A

### Battery pack (lithium-ion)

(Panasonic DMW-BMB9E): Information for your safety

<b>Voltage / capacity</b>	7.2 V / 895 mAh
---------------------------	-----------------

Specifications are subject to change without notice.

## Limited Warranty (ONLY FOR AUSTRALIA)

# Panasonic Warranty

- The product is warranted for 12 months from the date of purchase. Subject to the conditions of this warranty Panasonic or its Authorised Service Centre will perform necessary service on the product without charge for parts or labour, if in the opinion of Panasonic, the product is found to be faulty within the warranty period.
- This warranty only applies to Panasonic products purchased in Australia and sold by Panasonic Australia or its Authorised Distributors or Dealers and only where the products are used and serviced within Australia or its territories. Warranty cover only applies to service carried out by a Panasonic Authorised Service Centre and only if valid proof of purchase is presented when warranty service is requested.
- This warranty only applies if the product has been installed and used in accordance with the manufacturer's recommendations (as noted in the operating instructions) under normal use and reasonable care (in the opinion of Panasonic). The warranty covers normal domestic use only and does not cover damage, malfunction or failure resulting from use of incorrect voltages, incorrect installation, accident, misuse, neglect, build-up of dirt or dust, abuse, maladjustment of customer controls, mains supply problems, thunderstorm activity, infestation by insects or vermin, tampering or repair by unauthorised persons (including unauthorised alterations), introduction of sand, humidity or liquids, commercial use such as hotel, office, restaurant, or other business or rental use of the product, exposure to abnormally corrosive conditions or any foreign object or matter having entered the product.
- This warranty does not cover the following items unless the fault or defect existed at the time of purchase:
  - Cabinet Part(s)
  - Video or Audio Tapes
  - SD cards or USB devices
  - User replaceable Batteries
  - DVD, Blu-ray or Recordable Discs
  - Video / Audio Heads from wear and tear in normal use
  - Information stored on Hard Disk Drive, USB stick or SD card
  - DTV reception issues caused by TV Aerial / Cabling / Wall socket(s) etc
- Some products may be supplied with Ethernet connection hardware. The warranty is limited on such products and will not cover
  - Internet and or DLNA connection / setup related problems
  - Access fees and or charges incurred for internet connection
  - The use of incompatible software or software not specifically stipulated in the product operations manual; and
  - Any indirect or consequential costs associated with the incorrect use or misuse of the hardware, its connection to the internet or any other device.
- To claim warranty service, when required, you should:
  - Telephone Panasonic's Customer Care Centre on 132600 or visit our website referred to below and use the Service Centre Locator for the name/address of the nearest Authorised Service Centre.
  - Send or take the product to a Panasonic Authorised Service Centre together with your proof of purchase receipt as a proof of purchase date. Please note that freight and insurance to and / or from your nearest Authorised Service Centre must be arranged by you.
  - Note that home or pick-up/delivery service is available for the following products in the major metropolitan areas of Australia or the normal operating areas of the nearest Authorised Service Centres:
    - Plasma/LCD televisions / displays (screen size greater than 103 cm)
- The warranties hereby conferred do not extend to, and exclude, any costs associated with the installation, de-installation or re-installation of a product, including costs related to the mounting, de-mounting or re-mounting of any screen, (and any other ancillary activities), delivery, handling, freighting, transportation or insurance of the product or any part thereof or replacement of and do not extend to, and exclude, any damage or loss occurring by reason of, during, associated with, or related to such installation, de-installation, re-installation or transit.

Panasonic Authorised Service Centres are located in major metropolitan areas and most regional centres of Australia, however, coverage will vary dependant on product. For advice on exact Authorised Service Centre locations for your product, please telephone our Customer Care Centre on 132600 or visit our website and use the Service Centre Locator.

In addition to your rights under this warranty, Panasonic products come with consumer guarantees that cannot be excluded under the Australian Consumer Law. If there is a major failure with the product, you can reject the product and elect to have a refund or to have the product replaced or if you wish you may elect to keep the goods and be compensated for the drop in value of the goods. You are also entitled to have the product repaired or replaced if the product fails to be of acceptable quality and the failure does not amount to a major failure.

If there is a major failure in regard to the product which cannot be remedied then you must notify us within a reasonable period by contacting the Panasonic Customer Care Centre. If the failure in the product is not a major failure then Panasonic may choose to repair or replace the product and will do so in a reasonable period of time from receiving notice from you.

**THIS WARRANTY CARD AND THE PURCHASE DOCKET (OR SIMILAR PROOF OF PURCHASE)  
SHOULD BE RETAINED BY THE CUSTOMER AT ALL TIMES**

If you require assistance regarding warranty conditions or any other enquiries, please visit the **Panasonic Australia** website [www.panasonic.com.au](http://www.panasonic.com.au) or contact by phone on **132 600**  
*If phoning in, please ensure you have your operating instructions available.*

**Panasonic Australia Pty. Limited**

ACN 001 592 187 ABN 83 001 592 187

1 Innovation Road, Macquarie Park NSW 2113

PRO-031-F11 Issue: 4.0

01-01-2011

**HDMI**

**AVCHD**™

**DOLBY**  
**DIGITAL**



- SDXC Logo is a trademark of SD-3C, LLC.
- HDMI, the HDMI Logo, and High-Definition Multimedia Interface are trademarks or registered trademarks of HDMI Licensing LLC in the United States and other countries.
- “AVCHD” and the “AVCHD” logo are trademarks of Panasonic Corporation and Sony Corporation.
- Manufactured under license from Dolby Laboratories. Dolby and the double-D symbol are trademarks of Dolby Laboratories.
- Windows and Windows Vista are either registered trademarks or trademarks of Microsoft Corporation in the United States and/or other countries.
- Mac and Mac OS are trademarks of Apple Inc., registered in the U.S. and other countries.
- QuickTime and the QuickTime logo are trademarks or registered trademarks of Apple Inc., used under license therefrom.
- This product uses “DynaFont” from DynaComware Corporation. DynaFont is a registered trademark of DynaComware Taiwan Inc.
- Other names, company names, and product names mentioned in these instructions are trademarks or registered trademarks of the companies concerned.

Panasonic Corporation  
Web Site: <http://panasonic.net>

© Panasonic Corporation 2013

