

Panasonic®

Operating Instructions

Digital Cordless Answering System

Model No. **KX-TG7861NZ**
KX-TG7862NZ

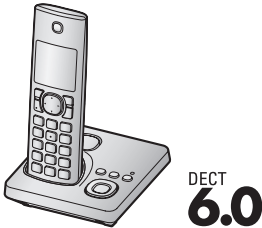

Model shown is KX-TG7861.

***Before initial use, see “Getting Started”
on page 9.***

Thank you for purchasing a Panasonic product.

Please read these operating instructions before using the unit and save them for future reference.

**Please access our online customer survey:
<http://panasonic.net/pcc/tel/q>**

Table of Contents

Introduction		
Model composition	3	
Accessory information	3	
Important Information		
For your safety	5	
Important safety instructions	6	
For best performance	7	
Other information	7	
Specifications	8	
Getting Started		
Setting up	9	
Note when setting up	10	
Controls	11	
Display	12	
Screen saver mode	13	
Turning the power on/off	13	
Initial settings	13	
One touch eco mode	14	
Display mode	14	
Making/Answering Calls		
Making calls	15	
Answering calls	15	
Useful features during a call	16	
Key lock	17	
Shared Phonebook		
Shared phonebook	18	
Speed Dial		
Speed dial	20	
Programming		
Programmable settings	21	
Special programming	26	
Registering a unit	29	
Caller ID Service		
Using Caller ID service	31	
Caller list	31	
Answering System		
Answering system	33	
Turning the answering system on/ off	33	
Greeting message	33	
Listening to messages using the base unit	34	
Listening to messages using the handset	34	
Remote operation	35	
Answering system settings	37	
Voice Mail Service		
Voice mail service	38	
Intercom/Locator		
Intercom	39	
Handset locator	39	
Transferring calls, conference calls	39	
Useful Information		
Character entry	40	
Error messages	42	
Troubleshooting	43	
Warranty	47	
Index		
Index.....	48	

Model composition

Series	Model No.	Base unit	Handset	
		Part No.	Part No.	Quantity
KX-TG7861 series	KX-TG7861*1	KX-TG7861	KX-TGA786	1
	KX-TG7862	KX-TG7861	KX-TGA786	2

*1 Feature differences: Intercom calls can be made between handsets by purchasing and registering one or more optional handsets (page 4).

- The suffix (NZ) in the following model numbers will be omitted in these instructions:
KX-TG7861NZ/KX-TG7862NZ

Accessory information

Supplied accessories

No.	Accessory item/Part number	Quantity	
		KX-TG7861	KX-TG7862
①	AC adaptor for base unit/PNLV226AL	1	1
②	Telephone line cord	1	1
③	Rechargeable batteries*1	2	4
④	Handset cover*2	1	2
⑤	Charger	–	1
⑥	AC adaptor for charger/PNLV233AL	–	1

*1 See page 4 for replacement battery information.

*2 The handset cover comes attached to the handset.

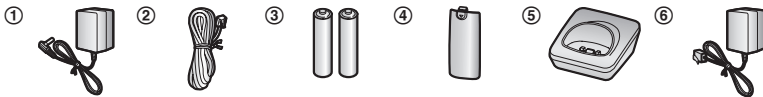

Introduction

Additional/replacement accessories

Please contact your nearest Panasonic dealer for sales information.

Accessory item	Model number
Rechargeable batteries	HHR-4MVT or HHR-4MRT*1
	Battery type: – Nickel metal hydride (Ni-MH) – 2 x AAA (R03) size for each handset
DECT repeater	KX-A405
Key finder	KX-TGA20AZ*2

*1 Replacement batteries may have a different capacity from that of the supplied batteries.

*2 By registering the key finder (4 max.) to a Panasonic Digital Cordless Phone and attaching it to an easy-to-lose item in advance, you can locate and find the mislaid item to which the key finder is attached. Please visit our Web site:

<http://panasonic.net/pcc/products/telephone/p/tga20/>

Please contact Panasonic or authorised sales department on the back cover for availability of key finder in your area.

Expanding your phone system

Handset (optional): KX-TGA786AZ	
<p>You can expand your phone system by registering optional handsets (6 max.) to a single base unit.</p> <ul style="list-style-type: none">• Optional handsets may be a different colour from that of the supplied handsets.	

Important Information

For your safety

To prevent severe injury and loss of life/property, read this section carefully before using the product to ensure proper and safe operation of your product.

WARNING

Power connection

- Use only the power source marked on the product.
- Do not overload power outlets and extension cords. This can result in the risk of fire or electric shock.
- Completely insert the AC adaptor/power plug into the power outlet. Failure to do so may cause electric shock and/or excessive heat resulting in a fire.
- Regularly remove any dust, etc. from the AC adaptor/power plug by pulling it from the power outlet, then wiping with a dry cloth. Accumulated dust may cause an insulation defect from moisture, etc. resulting in a fire.
- Unplug the product from power outlets if it emits smoke, an abnormal smell, or makes an unusual noise. These conditions can cause fire or electric shock. Confirm that smoke has stopped emitting and contact an authorised service centre.
- Unplug from power outlets and never touch the inside of the product if its casing has been broken open.
- Never touch the plug with wet hands. Danger of electric shock exists.

Installation

- To prevent the risk of fire or electrical shock, do not expose the product to rain or any type of moisture.
- Do not place or use this product near automatically controlled devices such as automatic doors and fire alarms. Radio waves emitted from this product may cause such devices to malfunction resulting in an accident.

- Do not allow the AC adaptor or telephone line cord to be excessively pulled, bent or placed under heavy objects.

Operating safeguards

- Unplug the product from power outlets before cleaning. Do not use liquid or aerosol cleaners.
- Do not disassemble the product.
- Do not spill liquids (detergents, cleansers, etc.) onto the telephone line cord plug, or allow it to become wet at all. This may cause a fire. If the telephone line cord plug becomes wet, immediately pull it from the telephone wall socket, and do not use.

Medical

- Consult the manufacturer of any personal medical devices, such as pacemakers or hearing aids, to determine if they are adequately shielded from external RF (radio frequency) energy. (The product operates in the frequency range of 1.88 GHz to 1.90 GHz, and the RF transmission power is 250 mW (max.).)
- Do not use the product in health care facilities if any regulations posted in the area instruct you not to do so. Hospitals or health care facilities may be using equipment that could be sensitive to external RF energy.

CAUTION

Installation and location

- Never install telephone wiring during an electrical storm.
- Never install telephone line sockets in wet locations unless the socket is specifically designed for wet locations.
- Never touch uninsulated telephone wires or terminals unless the telephone line has been disconnected at the network interface.
- Use caution when installing or modifying telephone lines.
- The AC adaptor is used as the main disconnect device. Ensure that the AC outlet is installed near the product and is easily accessible.
- This product is unable to make calls when:

Important Information

- the handset batteries need recharging or have failed.
- there is a power failure.
- the key lock feature is turned on.

Battery

- We recommend using the batteries noted on page 4. **USE ONLY rechargeable Ni-MH batteries AAA (R03) size.**
- Do not mix old and new batteries.
- Do not open or mutilate the batteries. Released electrolyte from the batteries is corrosive and may cause burns or injury to the eyes or skin. The electrolyte is toxic and may be harmful if swallowed.
- Exercise care when handling the batteries. Do not allow conductive materials such as rings, bracelets, or keys to touch the batteries, otherwise a short circuit may cause the batteries and/or the conductive material to overheat and cause burns.
- Charge the batteries provided with or identified for use with this product only, in accordance with the instructions and limitations specified in this manual.
- Only use a compatible base unit (or charger) to charge the batteries. Do not tamper with the base unit (or charger). Failure to follow these instructions may cause the batteries to swell or explode.

General notices

- This equipment will be inoperable when mains power fails.
- When a failure occurs which results in the internal parts becoming accessible, disconnect the power supply cord immediately and return this unit to an authorised service centre.
- Disconnect the telecom connection before disconnecting the power connection prior to relocating the equipment, and reconnect the power first.
- No “111” or other calls can be made from this device during a mains power failure.
- This equipment shall not be set to make automatic calls to the Telecom “111” Emergency Service.
- To minimise the possibility of lightning damage, when you know that a

thunderstorm is coming, we recommend that you:

- Unplug the telephone line cord from the phone socket.
- Unplug the AC adaptor from the AC power outlet.
- The earpiece on the handset is magnetised and may retain small metallic objects.
- The unit’s answering system only responds to Distinctive Alert cadence(s) DA1 and DA3.
- Not all telephones will respond to incoming ringing when connected to the extension socket.
- This equipment may not provide for the effective hand-over of a call to another device connected to the same line.
- The grant of a Telepermit for any item of terminal equipment indicates only that Telecom has accepted that the item complies with minimum conditions for connection to its network. It indicates no endorsement of the product by Telecom, nor does it provide any sort of warranty. Above all, it provides no assurance that any item will work correctly in all respects with another item of Telepermitted equipment of a different make or model, nor does it imply that any product is compatible with all of Telecom’s network services.

Important notice:

- Under power failure conditions, this telephone may not operate. Please ensure that a separate telephone, not dependent on local power, is available for emergency use.

Important safety instructions

When using your product, basic safety precautions should always be followed to reduce the risk of fire, electric shock, and injury to persons, including the following:

1. Do not use this product near water for example, near a bathtub, washbowl, kitchen sink, or laundry tub, in a wet basement or near a swimming pool.
2. Avoid using a telephone (other than a cordless type) during an electrical storm.

Important Information

There may be a remote risk of electric shock from lightning.

- Do not use the telephone to report a gas leak in the vicinity of the leak.
- Use only the power cord and batteries indicated in this manual. Do not dispose of batteries in a fire. They may explode. Check with local codes for possible special disposal instructions.

SAVE THESE INSTRUCTIONS

For best performance

Base unit location/avoiding noise

The base unit and other compatible Panasonic units use radio waves to communicate with each other.

- For maximum coverage and noise-free communications, place your base unit:
 - at a convenient, high, and central location with no obstructions between the handset and base unit in an indoor environment.
 - away from electronic appliances such as TVs, radios, personal computers, wireless devices, or other phones.
 - facing away from radio frequency transmitters, such as external antennas of mobile phone cell stations. (Avoid putting the base unit on a bay window or near a window.)
- Coverage and voice quality depends on the local environmental conditions.
- If the reception for a base unit location is not satisfactory, move the base unit to another location for better reception.

Environment

- Keep the product away from electrical noise generating devices, such as fluorescent lamps and motors.
- The product should be kept free from excessive smoke, dust, high temperature, and vibration.
- The product should not be exposed to direct sunlight.
- Do not place heavy objects on top of the product.

- When you leave the product unused for a long period of time, unplug the product from the power outlet.
- The product should be kept away from heat sources such as radiators, cookers, etc. It should not be placed in rooms where the temperature is less than 0 °C or greater than 40 °C. Damp basements should also be avoided.
- The maximum calling distance may be shortened when the product is used in the following places: Near obstacles such as hills, tunnels, underground, near metal objects such as wire fences, etc.
- Operating the product near electrical appliances may cause interference. Move away from the electrical appliances.

Routine care

- Wipe the outer surface of the product with a soft moist cloth.**
- Do not use benzene, thinner, or any abrasive powder.

Other information

CAUTION: Risk of explosion if battery is replaced by an incorrect type. Dispose of used batteries according to the instructions.

Notice for product disposal, transfer, or return

- This product can store your private/confidential information. To protect your privacy/confidentiality, we recommend that you erase information such as phonebook or caller list entries from the memory before you dispose of, transfer, or return the product.

Important Information

Information on Disposal in other Countries outside the European Union



These symbols are only valid in the European Union. If you wish to discard these items, please contact your local authorities or dealer and ask for the correct method of disposal.

Specifications

- **Standard:**
GAP (Generic Access Profile)
- **Frequency range:**
1.88 GHz to 1.90 GHz
- **RF transmission power:**
Approx. 10 mW (average power per channel)
- **Power source:**
220–240 V AC, 50/60 Hz
- **Power consumption:**
Base unit:
Standby: Approx. 0.7 W
Maximum: Approx. 2.8 W
Charger:
Standby: Approx. 0.12 W
Maximum: Approx. 1.8 W
- **Operating conditions:**
0 °C–40 °C, 20 %–80 % relative air humidity (dry)

Note:

- Design and specifications are subject to change without notice.
- The illustrations in these instructions may vary slightly from the actual product.

Setting up

Connections

■ Base unit

- Use only the supplied Panasonic AC adaptor PNLV226AL.

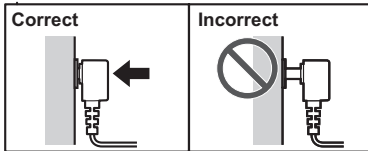
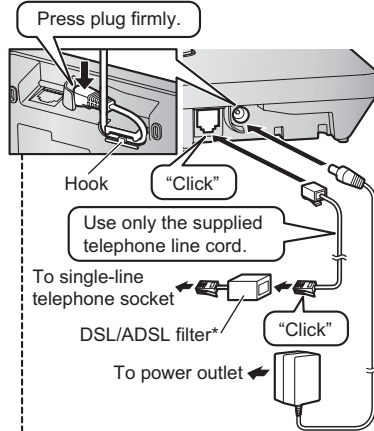

*DSL/ADSL filter (not supplied) is required if you have DSL/ADSL service.

■ Charger

- Use only the supplied Panasonic AC adaptor PNLV233AL.

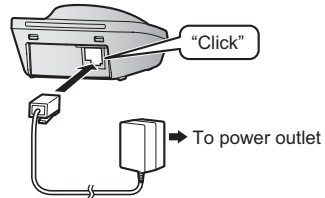

Battery installation

- USE ONLY Ni-MH batteries AAA (R03) size.
- Do NOT use Alkaline/Manganese/Ni-Cd batteries.
- Confirm correct polarities (+, -).

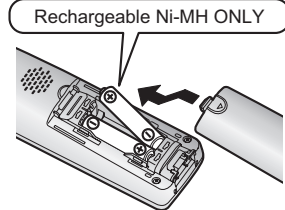
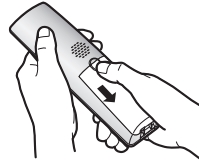

- When the date and time setting is displayed, see page 14.

Getting Started

Battery charging

Charge for about 7 hours.

- When the batteries are fully charged, "Fully charged" is displayed.

Confirm "Charging" is displayed.

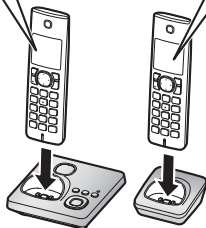

Note when setting up

Note for connections

- The AC adaptor must remain connected at all times. (It is normal for the adaptor to feel warm during use.)
- The AC adaptor should be connected to a vertically oriented or floor-mounted AC outlet. Do not connect the AC adaptor to a ceiling-mounted AC outlet, as the weight of the adaptor may cause it to become disconnected.
- The unit is not designed to be used with rotary/pulse dialling services.
- The unit's answering system will not answer incoming calls on your FaxAbility number.

During a power failure

The unit will not work during a power failure. We recommend connecting a corded-type telephone (without AC adaptor) to the same telephone line or to the same telephone line socket using a BT double adaptor.

Note for battery installation

- Use the supplied rechargeable batteries. For replacement, we recommend using the

Panasonic rechargeable batteries noted on page 4, 6.

- Wipe the battery ends (+, -) with a dry cloth.
- Avoid touching the battery ends (+, -) or the unit contacts.

Note for battery charging

- It is normal for the handset to feel warm during charging.
- Clean the charge contacts of the handset, base unit, and charger with a soft and dry cloth once a month. Before cleaning the unit, disconnect from power outlets and any telephone line cords. Clean more often if the unit is exposed to grease, dust, or high humidity.

Battery level

Icon	Battery level
	High
	Medium
	Low
	Needs charging.

Panasonic Ni-MH battery performance (supplied batteries)

Operation	Operating time
In continuous use	11 hours max.
Not in use (standby)	230 hours max.

Note:

- It is normal for batteries not to reach full capacity at the initial charge. Maximum battery performance is reached after a few complete cycles of charge/discharge (use).
- Actual battery performance depends on usage and ambient environment.
- Even after the batteries are fully charged, the handset can be left on the base unit or charger without any ill effect on the batteries.
- The battery level may not be displayed correctly after you replace the batteries. In

this case, place the handset on the base unit or charger and let it charge for at least 7 hours.

Controls

Handset

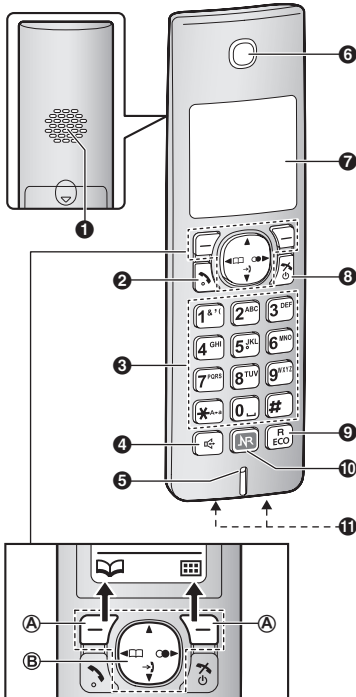

- 1 Speaker
- 2 **[Talk]** (Talk)
- 3 Dial keypad
- 4 **[Speakerphone]** (Speakerphone)
- 5 Microphone

- 6 Receiver
- 7 Display
- 8 **[Off/Power]** (Off/Power)
- 9 **[R/ECO]**
R: Recall/Flash
ECO: Eco mode shortcut key
- 10 **[NR]** (Noise reduction key)
- 11 Charge contacts

Control type

A Soft keys

The handset features 2 soft keys. By pressing a soft key, you can select the feature shown directly above it on the display.





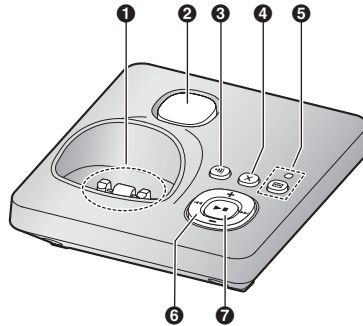

B Navigator key

- **[▲]**, **[▼]**, **[◀]**, or **[▶]**: Scroll through various lists and items.
- **[▲]** or **[▼]**: Adjust the receiver or speaker volume while talking.
- **[▼]** (📞): Caller list: View the caller list.
- **[◀]** (📖): Phonebook: View the phonebook entry.
- **[▶]** (📞): Redial: View the redial list.
- As all multiple items cannot be displayed on screen at the same time, you can quickly search the desired item to move screens by pressing **[▶]** or **[◀]**, instead of scrolling down or up line by line (page 14).

Base unit





















Getting Started

- 1 Charge contacts
- 2 Speaker
- 3  (Locator)
- 4  (Erase)
- 5  (Answer on)
Answer on indicator
- 6  (Volume up/down)
 (Repeat/Skip)
- 7  (Play/Stop)
Message indicator

Display

Handset display items







Item	Meaning
	Range status: The more bars visible, the closer the handset is to the base unit.
	Out of base unit range
	Paging, intercom mode
	Speakerphone is on. (page 15)
	The line is in use. <ul style="list-style-type: none"> • When flashing slowly: The call is put on hold. • When flashing rapidly: An incoming call is now being received.
	
	The base unit transmission power is set to "Low". (page 14)
	Noise reduction is set. (page 16)
	<ul style="list-style-type: none"> • When displayed next to the battery icon: Answering system is on. (page 33) • When displayed with a number: New messages have been recorded. (page 34)

Item	Meaning
	"Greeting Only" is selected as the caller's recording time. In this case, the answering system answers calls with a greeting message and caller messages are not recorded. (page 37)
	Battery level
	Alarm is on. (page 26)
	Equalizer is set. (page 17)
	Privacy mode is on. (page 24)
	Ringer volume is off. (page 15)
	Night mode is on. (page 27)
	Blocked call*1 (page 27, 32)
	New voice mail message received.*2 (page 38)
Line in use	Someone is using the line.
IN USE	Answering system is being used by another handset or the base unit.

*1 Caller ID subscribers only

*2 Voice mail subscribers only

Handset soft key icons

Icon	Action
	Returns to the previous screen or outside call.
	Displays the menu.
OK	Accepts the current selection.
	Makes a call. (page 15)
	Temporarily turns off the ringer for incoming calls. (page 16)
	Places a call on hold.
	Opens the phonebook.

Icon	Action
	Allows you to edit phone numbers. (page 28)
	Adds new entry. (page 20, 28)
	Displays the character entry mode for phonebook search. (page 18)
	Turns the key lock feature off. (page 17)
	Stops alarm. (page 26)
	Snooze button on the alarm. (page 26)
	Selects entries or handsets. (page 26)
	Plays a message.
	Stops recording or playback.
	Stores phone numbers. (page 15)
	Erases the selected item.
	Switches the screen to confirm the detailed information. (page 14)
	Allows you to make an intercom call. (page 39)
C	Erases a number/character.
	Puts the call on mute.

Handset main menu icons

The following icons are shown when you press (right soft key) in standby mode.

Icon	Feature
	Answer System
	Time Settings
	Intercom
	Initial Setup
	Caller List
	Key Finder ^{*1}
	Ringer Setup ^{*2}

*1 This icon is displayed when the key finder is registered.

*2 This menu icon is displayed when the key finder is not registered.

Screen saver mode

The backlight goes dark when on a call or turns off completely after 1 minute of inactivity if the handset is not on the base unit or charger.

Activate the handset display again by:

- pressing when on a call.
- pressing at all other times.

Turning the power on/off

Power on

Press for about 1 second.

Power off

Press for about 2 seconds.

Initial settings

■ Direct command code:

Programmable settings can be accessed by pressing (right soft key), (#), and then the corresponding code on the dial keypad (page 21).

Example: Press (right soft key)

.

■ Symbol meaning:

Example: : “OFF”

Press or to select the words in quotations.

Display language

1 (right soft key)

2 : Select your desired language. →

3

Getting Started

Date and time

Important:

- When you install the batteries for the first time, the handset may prompt you to set date and time. First press **[OK]**, then proceed to step 2.

- 1 **[☰]** (right soft key) **[#][1][0][1]**
- 2 Enter the current date, month, and year.
→ **[OK]**
Example: 15 July, 2013
[1][5][0][7][1][3]
 - You can select the date format by pressing **[#]**:
 - dd/mm/yy (date/month/year)
 - yy/mm/dd
- 3 Enter the current hour and minute.
Example: 9:30
[0][9][3][0]
 - You can select 24-hour or 12-hour clock format (“**AM**” or “**PM**”) by pressing **[*]**.
- 4 **[OK]** → **[🔌📶]**

Note:

- The date and time may be incorrect after a power failure. In this case, set the date and time again.

One touch eco mode

The **[R/ECO]** button on the handset enables you to activate the eco function with one touch.

By activating eco mode, your unit can reduce the base unit transmission power by up to 90 % in standby mode.

You can turn on/off one touch eco mode by just pressing **[R/ECO]**. The default setting is “**Normal**”.

- When the one touch eco mode is on: “**Low**” is temporarily displayed and **[ECO]** is shown on the handset display instead of **[Y]**.
- When the one touch eco mode is off: “**Normal**” is temporarily displayed and **[ECO]** goes off from the handset display.

Note:

- When there is another cordless phone nearby and it is in use, the base unit transmission power may not be reduced.
- Activating one touch eco mode reduces the range of the base unit in standby mode.
- If you set the repeater mode to “**On**” (page 30):
 - One touch eco mode is cancelled.
 - “**Eco Setup**” is not shown in the display menu (page 24).

Display mode

You can select to display either a single item or multiple items on one screen at a time for the following features:

- handset main menu icons in function menu
 - menu list, recorded message list, phonebook list, caller list, and redial list
- Select the desired setting:
- “**Multi Items**”: Multiple entries/all menu icons are shown on one screen at a time.
 - “**Single Item**”: An entry/a menu icon is shown on one screen at a time.
- The default setting is “**Multi Items**”.

Programming the display mode beforehand

- 1 **[☰]** (right soft key) **[#][1][9][2]**
- 2 **[↕]**: Select the desired setting. → **[OK]**
→ **[🔌📶]**

Note:

- When in multiple items display mode, you can move screens by pressing **[▶]** or **[◀]**, without scrolling down or up through the list:
 - Press **[▶]** to go to the next screen.
 - Press **[◀]** to return to the previous screen.
- When in multiple items display mode, you can switch the screen to confirm the detailed information by pressing **[☰••]**.

Making calls

- 1 Lift the handset and dial the phone number.
 - To correct a digit, press [C].
- 2 Press [📞].
- 3 When you finish talking, press [📞] or place the handset on the base unit or charger.

Using the speakerphone

- 1 Dial the phone number and press [📞].
 - Speak alternately with the other party.
- 2 When you finish talking, press [📞].

Note:

- For best performance, use the speakerphone in a quiet environment.
- To switch back to the receiver, press [📞]/[📞].

Adjusting the receiver or speaker volume

Press [▲] or [▼] repeatedly while talking.

Making a call using the redial list

The last 10 phone numbers dialled are stored in the redial list (each 24 digits max.).

- 1 [▶] (●)
- 2 [📞]: Select the desired phone number.
- 3 [📞]

Storing a number to the phonebook

- 1 [▶] (●)
- 2 [📞]: Select the desired phone number.
→ [≡] → [📞]
- 3 To store the name, continue from step 3, "Adding entries", page 18.

Erasing a number in the redial list

- 1 [▶] (●)

- 2 [📞]: Select the desired phone number.
→ [X]

- 3 [📞]: "Yes" → [OK] → [📞]

Pause (for PBX/long distance service users)

A pause is sometimes required when making calls using a PBX or long distance service. When storing a calling card access number and/or PIN in the phonebook, a pause is also needed (page 19).

Example: If you need to dial the line access number "0" when making outside calls with a PBX:

- 1 [0] → [▲] (Pause)

- 2 Dial the phone number. → [📞]

Note:

- A 3 second pause is inserted each time [▲] (Pause) is pressed.

Answering calls

- 1 Lift the handset and press [📞] or [📞] when the unit rings.
 - You can also answer the call by pressing any dial key from [0] to [9], [✳], or [#]. (**Any key answer feature**)
- 2 When you finish talking, press [📞] or place the handset on the base unit or charger.

Auto talk

You can answer calls simply by lifting the handset off the base unit or charger. You do not need to press [📞]. To turn this feature on, see page 24.

Adjusting the handset ringer volume

- **While the handset is ringing for an incoming call:**
Press [▲] or [▼] repeatedly to select the desired volume.

- **Programming the volume beforehand:**

- 1 [📞] (right soft key) [#]1[6][0]

Making/Answering Calls

- 2 **[↕]**: Select the desired volume.
- 3 **[OK]** → **[🔇]**

Temporary handset ringer off

While the handset is ringing for a call, you can turn the ringer off temporarily by pressing **[🔇]**.

Useful features during a call

Hold

This feature allows you to put an outside call on hold.

- 1 Press **[📞]** during an outside call.
- 2 **[↕]**: “Hold” → **[OK]**
- 3 To release hold, press **[📞]**.
 - Another handset user can take the call by pressing **[📞]**.

Note:

- If a call is kept on hold for more than 9 minutes, an alarm tone starts to sound. After 1 additional minute on hold, the call is disconnected.
- If another phone is connected to the same line, you can also take the call by lifting its handset.

Mute

While mute is turned on, you can hear the other party, but the other party cannot hear you.

- 1 Press **[🔇]** during conversation.
 - **[🔇]** flashes.
- 2 To return to the conversation, press **[🔇]** again.

Recall/flash

[R/ECO] allows you to use the special features of your host PBX such as transferring an extension call, or accessing optional telephone services.

Note:

- To change the recall/flash time, see page 24.

For Call Waiting or Call Waiting Caller ID service users

To use call waiting or Call Waiting Caller ID, you must first subscribe with your service provider/telephone company. This feature allows you to receive calls while you are already talking on the phone. If you receive a call while on the phone, you will hear a call waiting tone.

If you subscribe to both Caller ID and Call Waiting with Caller ID services, the 2nd caller's information is displayed after you hear the call waiting tone on the handset.

- 1 Press **[R/ECO]** to answer the 2nd call.
- 2 To switch between calls, press **[R/ECO]**.

Note:

- Please contact your service provider/telephone company for details and availability of this service in your area.

Handset noise reduction (NR key)

This feature allows you to hear the voice of the person you are talking to clearly, by reducing the surrounding noise coming from the other party's telephone.

Press **[NR]** to turn on/off while talking.

Note:

- When this feature is turned on, **[NR]** is displayed while talking.
- Depending on the environment where this handset is being used, this feature may not be effective.
- This feature is not available using the speakerphone.

Handset equalizer

This feature clarifies the voice of the person you are talking to, producing a more natural-sounding voice that is easier to hear and understand.

Making/Answering Calls

- 1 Press **[EQ]** while talking.
- 2 **[↕]**: "Equalizer" → **[OK]**
- 3 **[↕]**: Select the desired setting.
- 4 Press **[OK]** to exit.

Note:

- When this feature is turned on, **[EQ]** is displayed while talking.
- Depending on the condition and quality of your telephone line, this feature may emphasise existing line noise. If it becomes difficult to hear, turn this feature off.
- This feature is not available while using the speakerphone.

Call share

You can join an existing outside call.
To join the conversation, press **[☞]** when the other handset is on an outside call.

Note:

- To prevent other users from joining your conversations with outside callers, turn the privacy mode on (page 24).

Key lock

The handset can be locked so that no calls or settings can be made. Incoming calls can be answered, but all other functions are disabled while key lock is on.

To turn key lock on, press **[EQ]** (right soft key) for about 3 seconds.

- **[EQ]** is displayed.
- To turn key lock off, press **[EQ]** (right soft key) for about 3 seconds.

Note:

- Calls to emergency numbers cannot be made until key lock is turned off.

Shared Phonebook

Shared phonebook

The shared phonebook allows you to make calls without having to dial manually. Any handset registered to the base unit can use the shared phonebook. You can add 70 names and phone numbers to the shared phonebook.

Important:

- Only 1 person can access the shared phonebook at a time.

Adding entries

- 1 [📖] (left soft key) or [←] (📖) → [⌨]
- 2 [↕]: "New Entry" → [OK]
- 3 Enter the party's name (16 characters max.). → [OK]
 - You can change the character entry mode by pressing [RECO] (page 40).
- 4 Enter the party's phone number (24 digits max.). → [OK] 2 times
 - To add other entries, repeat from step 3.
- 5 [🔍]

Note:

- Your service provider/telephone company may charge you for a local call if the number dialled has the area code prefix included. If this is unacceptable, dial only the 7-digit local number. Do not dial the "0" prefix or the area code.

Finding and calling from a phonebook entry

Scrolling through all entries

- 1 [📖] (left soft key) or [←] (📖)
- 2 [↕]: Select the desired entry.
 - You can scroll through the phonebook entry by pressing and holding [▼] or [▲].
- 3 [🔍]

Searching by first character

- 1 [📖] (left soft key) or [←] (📖)
 - Change the character entry mode if necessary:
[🔍] → [↕]: Select the character entry mode. → [OK]
- 2 Press the dial key ([0] to [9], or [#]) which contains the character you are searching for (page 40).
 - Press the same dial key repeatedly to display the first entry corresponding to each character located on that dial key.
 - If there is no entry corresponding to the character you selected, the next entry is displayed.
- 3 [↕]: Scroll through the phonebook if necessary.
- 4 [🔍]

Editing entries

- 1 Find the desired entry (page 18). → [⌨]
- 2 [↕]: "Edit" → [OK]
- 3 Edit the name if necessary (16 characters max.; page 40). → [OK]
- 4 Edit the phone number if necessary (24 digits max.). → [OK] 2 times → [🔍]

Erasing entries

Erasing an entry

- 1 Find the desired entry (page 18). → [⌨]
- 2 [↕]: "Erase" → [OK]
- 3 [↕]: "Yes" → [OK] → [🔍]

Erasing all entries

- 1 [📖] (left soft key) or [←] (📖) → [⌨]
- 2 [↕]: "Erase All" → [OK]
- 3 [↕]: "Yes" → [OK]
- 4 [↕]: "Yes" → [OK] → [🔍]

Chain dial

This feature allows you to dial phone numbers in the phonebook while you are on a call. This feature can be used, for example, to dial a calling card access number or bank account PIN that you have stored in the phonebook, without having to dial manually.

- 1 During an outside call, press [☰].
- 2 [↕]: “Phonebook” → [OK]
- 3 [↕]: Select the desired entry.
- 4 Press [↵] (right soft key) to dial the number.

Note:

- When storing a calling card access number and your PIN in the phonebook as one phonebook entry, press [⏸] (Pause) to add pauses after the number and PIN as necessary (page 15).

Speed Dial

Speed dial

You can assign 1 phone number to each of the dial keys ([1] to [3]) on the handset.

Adding phone numbers to speed dial keys

■ By entering phone numbers:

- 1 Press and hold the desired speed dial key ([1] to [3]). → [OK]
- 2 [↕]: "Manual" → [OK]
- 3 Enter the party's name (16 characters max.; page 40). → [OK]
- 4 Enter the party's phone number (24 digits max.). → [OK] 2 times → [OK]

■ From the shared phonebook:

- 1 Press and hold the desired speed dial key ([1] to [3]). → [OK]
- 2 [↕]: "Phonebook" → [OK]
- 3 [↕]: Select the desired entry.
- 4 [OK] → [OK]

Note:

- If you edit a phonebook entry which is assigned to a speed dial key, the edited entry does not transfer to the speed dial key.

Editing an entry

- 1 Press and hold the desired speed dial key ([1] to [3]). → [OK]
- 2 [↕]: "Edit" → [OK]
- 3 Edit the name if necessary (16 characters max.; page 40). → [OK]
- 4 Edit the phone number if necessary (24 digits max.). → [OK] 2 times → [OK]

Erasing an entry

- 1 Press and hold the desired speed dial key ([1] to [3]). → [OK]
- 2 [↕]: "Erase" → [OK]

3 [↕]: "yes" → [OK]

4 [OK]

Viewing speed dial key assignments

You can see the speed dial key assignments on the handset display.

Press and hold the desired speed dial key ([1] to [3]).

Making a call using a speed dial key

- 1 Press and hold the desired speed dial key ([1] to [3]).
- 2 [OK]



Programmable settings

You can customise the unit by programming the following features using the handset. To access the features, there are 2 methods.

■ Scrolling through the display menus

- 1  (right soft key)
- 2 Press **[▼]**, **[▲]**, **[▶]**, or **[◀]** to select the desired main menu. → **[OK]**
- 3 Press **[▼]** or **[▲]** to select the desired item from the next sub-menus. → **[OK]**
- 4 Press **[▼]** or **[▲]** to select the desired setting. → **[OK]**
 - This step may vary depending on the feature being programmed.
 - To exit the operation, press **[✕]**.

■ Using the direct command code

- 1  (right soft key) → Enter the desired code.
Example: Press  (right soft key) **#101**.
- 2 Select the desired setting. → **[OK]**
 - This step may vary depending on the feature being programmed.
 - To exit the operation, press **[✕]**.

Note:

- In the following table, < > indicates the default settings.
- In the following table,  indicates the reference page number.
- Display menu order and sub-menu may vary depending on your model.

Display the menu tree and direct command code table

Main menu:  "Answer System"

Sub-menu 1	Sub-menu 2	Settings	Code	
Message List	–	–	#329	34
Play New Msg.	–	–	#323	34
Play All Msg.	–	–	#324	34
Erase All Msg.*1	–	–	#325	35
Greeting	Start REC*1 (Record greeting)	–	#302	33
	Play Greeting	–	#303	34
	Default*1 (Reset to pre-recorded greeting)	–	#304	34

Programming

Sub-menu 1	Sub-menu 2	Settings	Code	
Settings	Number of Rings ^{*1}	2-9: 2-9 Rings 5: <5 Rings> 0: Auto	#211	37
	Recording Time ^{*1}	1: 1 Minute 3: <3 Minutes> 0: Greeting Only ^{*2}	#305	37
	Remote Code ^{*1}	-	#306	36
	Call Screening	1: <On> 0: Off	#310	33
Answer On ^{*1}	-	-	#327	33
Answer Off ^{*1}	-	-	#328	33

Main menu:  "Time Settings"

Sub-menu 1	Sub-menu 2	Settings	Code	
Set Date/Time ^{*1}	-	-	#101	14
Memo Alarm	1-3: Alarm1-3	1: Once 2: Daily 3: Weekly 0: <Off>	#720	26
Time Adjustment ^{*1, *3}	-	1: <Caller ID> 0: Manual	#226	-

Main menu:  "Intercom"

Operation	Code	
Paging the desired unit.	#274	39

Programming

Main menu:  "Initial Setup"

Sub-menu 1	Sub-menu 2	Settings	Code	
Ringer Setup	Ringer Volume – Handset	0-6: Off-6 <6>	#160	15
	Ringer Volume – Base Unit ^{*1}	0-6: Off-6 <3>	#*160	–
	Ringtone ^{*4, *5} (Handset)	<Ringtone 1>	#161	–
	Night Mode – On/Off		#238	27
	Night Mode – Start/End	<23:00/06:00>	#237	27
	Night Mode – Ring Delay	1: 30 sec. 2: <60 sec.> 3: 90 sec. 4: 120 sec. 0: No Ringing	#239	27
	First Ring ^{*1, *6}	1: <On> 0: Off	#173	–
Time Settings	Set Date/Time ^{*1}	–	#101	14
	Memo Alarm – 1-3: Alarm1-3	1: Once 2: Daily 3: Weekly 0: <Off>	#720	26
	Time Adjustment ^{*1, *3}	1: <Caller ID> 0: Manual	#226	–
Handset Name	–	–	#104	27
Key Finder Setup ^{*7} – 1: Add new device (for Finder1) ^{*8} – 2: Add new device (for Finder2) – 3: Add new device (for Finder3) – 4: Add new device (for Finder4)	Change Name ^{*1}	Finder1	#6561	–
		Finder2 ^{*9}	#6562 ^{*10}	
		Finder3 ^{*9}	#6563 ^{*10}	
		Finder4 ^{*9}	#6564 ^{*10}	
	Register	–	#6571	–
			#6572 ^{*10}	
			#6573 ^{*10}	
			#6574 ^{*10}	
	Cancel Register	–	#6581	–
			#6582 ^{*10}	
			#6583 ^{*10}	
			#6584 ^{*10}	

Programming

Sub-menu 1	Sub-menu 2	Settings	Code	
Caller Barred ^{*1}	–	–	#217	27
Speed Dial	–	–	#261	20
Eco Setup	Transmission Power ^{*1}	1: <Normal> 2: Low	#725	14
Display Setup	Wallpaper	<Wallpaper1>	#181	–
	Clock	1: <On> 0: Off	#198	–
	Display Colour	1: <Colour1> 2: Colour2	#182	–
	Display Mode	1: <Multi Items> 0: Single Item	#192	14
	LCD in charging ^{*11} (LCD backlight)	1: <On> 0: Off	#191	–
	Contrast (Display contrast)	1-6: Contrast 1-6 <Contrast 3>	#145	–
Keytones ^{*12}	–	1: <On> 0: Off	#165	–
Area Code ^{*1}	–	–	#255	28
Call Restrict ^{*1}	–	–	#256	28
Auto Talk ^{*13}	–	1: On 0: <Off>	#200	15
Line Setup	Recall/Flash ^{*1, *14}	0: 900 msec. 1: 700 msec. 2: <600 msec.> 3: 400 msec. 4: 300 msec. 5: 250 msec. *: 200 msec. #: 160 msec. 6: 110 msec. 7: 100 msec. 8: 90 msec. 9: 80 msec.	#121	16
Privacy Mode ^{*1, *15}	–	1: On 0: <Off>	#194	–
Base Unit PIN ^{*1}	–	<0000>	#132	29
Repeater Mode ^{*1}	–	1: On 0: <Off>	#138	30
Register	Register H.set	–	#130	29
	Cancel Register ^{*2}	–	#131	29
Language	Display	<English>	#110	13

Programming

Main menu:  "Caller List"

Operation	Code	
Viewing the caller list.	#213	31

Main menu:  "Key Finder"^{*7}

Sub-menu 1	Sub-menu 2	Settings	Code	
Search	–	–	#655	–
Battery Check	–	–		

Main menu:  "Ringer Setup"^{*16}

Sub-menu 1	Sub-menu 2	Settings	Code	
Ringer Volume	Handset	0-6: Off-6 <6>	#160	15
	Base Unit ^{*1}	0-6: Off-6 <3>	#*160	–
Ringtone ^{*4, *5} (Handset)	–	<Ringtone 1>	#161	–
Night Mode	On/Off	1: On 0: <Off>	#238	27
	Start/End	<23:00/06:00>	#237	27
	Ring Delay	1: 30 sec. 2: <60 sec.> 3: 90 sec. 4: 120 sec. 0: No Ringing	#239	27
First Ring ^{*1, *6}	–	1: <On> 0: Off	#173	–

- *1 If you program these settings using one of the handsets, you do not need to program the same item using another handset.
- *2 This menu is not displayed when scrolling through the display menus. It is only available in direct command code.
- *3 This feature allows the unit to automatically adjust the date and time each time caller information including date and time is received.
To turn this feature on, select "Caller ID". To turn this feature off, select "Manual".
(Caller ID subscribers only)
To use this feature, set the date and time first (page 14).
- *4 The ringer tone may continue to play for several seconds even if the caller has already hung up. You may either hear a dial tone or no one on the line when you answer the call.
- *5 The preset melodies in this product ("Ringtone 3" - "Ringtone 20") are used with permission of © 2012 Copyrights Vision Inc.
- *6 If you do not want the unit to ring before the caller information is received, set to "Off".
(Caller ID subscribers only)
You can only remove the first ring if the unit rings 2 times or more by default, which depends on your service provider/telephone company.
- *7 This setting is available when you have the key finder (KX-TGA20AZ). Read the installation guide for more information on the key finder.
- *8 For models with supplied key finders, the display shows "1: Finder1".

Programming

- *9 If you register 2 or more key finders.
- *10 If you have 2 or more key finders.
- *11 You can set the handset display backlight while on charge.
 - “On”: Backlight is on (dimmed).
 - “Off”: Backlight turns off after 10 seconds of charging.
- *12 Turn this feature off if you prefer not to hear key tones while you are dialling or pressing any keys, including confirmation tones and error tones.
- *13 If you subscribe to a Caller ID service and want to view the caller's information after lifting up the handset to answer a call, turn off this feature.
- *14 The recall/flash time depends on your telephone exchange or host PBX. Contact your PBX supplier if necessary.
- *15 To prevent other users from joining your conversations with outside callers, turn this feature on.
- *16 This menu icon is displayed when the key finder is not registered.

Special programming

Alarm

An alarm sounds at the set time for 1 minute and is repeated 5 times at 5 minute intervals (snooze function). A text memo can also be displayed for the alarm. A total of 3 separate alarm times can be programmed for each handset. You can set one of 3 different alarm options (once, daily, or weekly) for each alarm time.

Important:

- Set the date and time beforehand (page 14).

- 1 **[☐]** (right soft key) **[#]7[2]0**
- 2 Select an alarm by pressing **[1]** to **[3]**. → **[OK]**
- 3 **[↕]**: Select the desired alarm option. → **[OK]**

“Off”
Turns alarm off. Go to step 9.

“Once”
An alarm sounds once at the set time.

“Daily”
An alarm sounds daily at the set time.
Go to step 5.

“Weekly”

Alarm sounds weekly at the set time(s).

- 4 Proceed with the operation according to your selection in step 3.
 - **Once:**
Enter the desired date and month. → **[OK]**
 - **Weekly:**
[↕]: Select the desired day of the week and press **[✓]**. → **[OK]**
- 5 Set the desired time. → **[OK]**
- 6 Enter a text memo (10 characters max.; page 40). → **[OK]**
- 7 **[↕]**: Select the desired alarm tone. → **[OK]**
 - We recommend selecting a different ringer tone from the one used for outside calls.
- 8 **[↕]**: Select the desired snooze setting. → **[OK]**
- 9 **[OK]** → **[🔔]**
 - When the alarm is set, **[🔔]** is displayed.

Note:

- Press **[🔔]** to stop the alarm completely.
- When the handset is in use, the alarm will not sound until the handset is in standby mode.
- Press any dial key or **[🔔]** to stop the sound but keep the snooze function activated.

- If you want to make an outside call when the snooze function is activated, please stop the snooze function before making the call.

Night mode

Night mode allows you to select a period of time during which the handset will not ring for outside calls. This feature is useful for time periods when you do not want to be disturbed, for example, while sleeping. Night mode can be set for each handset.

Important:

- Set the date and time beforehand (page 14).
- We recommend turning the base unit ringer off (page 23) in addition to turning the night mode on.
- If you have set the alarm, the alarm sounds even if the night mode is turned on.

Turning night mode on/off

- 1 **[☐]** (right soft key) **#|2|3|8**
- 2 **[↕]**: Select the desired setting. → **[OK]**
 - If you select “off”, press **[🔕]** to exit.
- 3 Enter the desired hour and minute you wish to start this feature. → **[OK]**
 - You can select 24-hour or 12-hour clock format (“AM” or “PM”) by pressing **[☒]**.
- 4 Enter the desired hour and minute you wish to end this feature. → **[OK]**
- 5 **[🔕]**
 - When the night mode is set, **[🔕]** is displayed.

Changing the start and end time

- 1 **[☐]** (right soft key) **#|2|3|7**
- 2 Continue from step 3, “Turning night mode on/off”, page 27.

Setting the ring delay

This setting allows the handset to ring during night mode if the caller waits long enough.

After the selected amount of time passes, the handset rings. If you select “No Ringing”, the handset never rings during night mode.

- 1 **[☐]** (right soft key) **#|2|3|9**
- 2 **[↕]**: Select the desired setting. → **[OK]**
→ **[🔕]**

Note:

- When the answering system answers the call, this feature does not work.

Changing the handset name

Each handset can be given a customised name (“Bob”, “Kitchen”, etc.). This is useful when you make intercom calls between handsets. You can also select whether or not the handset name is displayed in standby mode. The default setting is “No”. If you select “Yes” without entering any handset name, “Handset 1” to “Handset 6” is displayed.

- 1 **[☐]** (right soft key) **#|1|0|4**
- 2 Enter the desired name (max. 10 characters; page 40).
 - If not required, go to step 3.
- 3 **[OK]**
- 4 **[↕]**: Select the desired setting. → **[OK]**
2 times
- 5 **[🔕]**

Incoming call barring (Caller ID subscribers only)

This feature allows the unit to reject calls from specified phone numbers that you do not want to answer such as junk calls.

When a call is received, the unit does not ring while the caller is being identified. If the phone number matches an entry in the call barred list, the unit emits no sound to the caller, and disconnects the call.

Important:

- When the unit receives a call from a number that is stored in the call barred list, the call is logged in the caller list (page 31) with **[🔕]** after the call is disconnected.

Programming

Storing unwanted callers

You can store up to 30 phone numbers in the call barred list.

Important:

- You must store the phone number with an area code in the call barred list.

■ From the caller list:

- 1 [v] (+)
- 2 [↕]: Select the entry to be barred. → [≡▪] → [☐]
- 3 [↕]: "Save CID" → [OK]
- 4 [↕]: "Caller Barred" → [OK]
- 5 [↕]: "Yes" → [OK] → [✕]

■ By entering phone numbers:

- 1 [☐] (right soft key) [#][2][1][7] → [☑]
- 2 Enter the phone number (24 digits max.). → [OK]
 - To erase a digit, press [C].
- 3 [✕]

Viewing/editing/erasing bar call numbers

- 1 [☐] (right soft key) [#][2][1][7]
- 2 [↕]: Select the desired entry.
 - To exit, press [✕].
- 3 To edit a number:
[☑] → Edit the phone number. → [OK] → [✕]
To erase a number:
[X] → [↕]: "Yes" → [OK] → [✕]

Note:

- When editing, press the desired dial key to add, [C] to erase.

Storing an area code to be deleted automatically

In some situations, phone numbers stored automatically in the caller list (page 31) will include area codes. If you do not want to dial the area code when making calls from the

caller list, you can store the area code which you want the unit to delete automatically.

Example: You have stored the area code "09". If you make a call from the caller list to the phone number "09-456-7890", the unit dials "456-7890".

- 1 [☐] (right soft key) [#][2][5][5]
- 2 Enter an area code (5 digits max.). → [OK] → [✕]

Note:

- The use of this feature can prevent a National Call from being dialled. E.g., in the case of the South Island, the "03" will be omitted and will therefore prevent a National Call to other areas of the South Island.

Setting call restriction

You can restrict selected handsets from dialling certain numbers. You can assign up to 6 phone numbers to be restricted, and select which handsets are to be restricted. Storing area codes here prevents the restricted handsets from dialling any phone number in that area code.

- 1 [☐] (right soft key) [#][2][5][6]
- 2 Enter the base unit PIN (default: "0000").
 - If you forget your PIN, contact an authorised service centre.
- 3 Select the handsets to be restricted by pressing [1] to [6].
 - All handsets registered to the base unit are displayed.
 - "✓" is displayed next to the selected handset numbers.
 - To cancel a selected handset, press the same dial key again. "✓" disappears.
- 4 [OK]
- 5 Select a memory location by pressing [1] to [6]. → [OK]
- 6 Enter the phone number or area code to be restricted (8 digits max.). → [OK] → [✕]
 - To erase a restricted number, press [C].

Changing the base unit PIN (Personal Identification Number)

Important:

- If you change the PIN, please make note of your new PIN. The unit will not reveal the PIN to you. If you forget your PIN, contact an authorised service centre.

- 1 **[M]** (right soft key) **[#132]**
- 2 Enter the current 4-digit base unit PIN (default: "0000").
- 3 Enter the new 4-digit base unit PIN. → **[OK]**
- 4 **[↕]**: "Yes" → **[OK]** → **[*0]**

Registering a unit

Operating additional units

Additional handsets

Up to 6 handsets can be registered to the base unit.

Important:

- The additional handset model recommended for use with this unit is noted on page 4. If another handset model is used, certain operations may not be available.

Registering a handset to the base unit

The supplied handset and base unit are pre-registered. If for some reason the handset is not registered to the base unit (for example, **Y** is displayed even when the handset is near the base unit), re-register the handset.

- 1 **Handset:**
[M] (right soft key) **[#130]**
- 2 **Base unit:**
Press and hold **[*0]** for about 5 seconds, until the registration tone sounds.

- If all registered handsets start ringing, press **[*0]** again to stop, then repeat this step.
- The next step must be completed within 90 seconds.

3 Handset:

[OK] → Wait until "Base PIN" is displayed. → Enter the base unit PIN (default: "0000"). → **[OK]**

- If you forget your PIN, contact an authorised service centre.
- When the handset has been registered successfully, **Y** is displayed.

Note:

- While registering, "Base in registering" is displayed on all registered handsets.
- When you purchase an additional handset, refer to the additional handset's installation manual for registration.

Deregistering a handset

A handset can cancel its own registration to the base unit, or other handsets registered to the same base unit. This allows the handset to end its wireless connection with the system.

- 1 **[M]** (right soft key) **[#131]**
 - All handsets registered to the base unit are displayed.
- 2 **[↕]**: Select the handset you want to cancel. → **[OK]**
- 3 **[↕]**: "Yes" → **[OK]**
 - A confirmation tone sounds.
 - The handset does not beep when cancelling its own registration.
- 4 **[*0]**

Increasing the range of the base unit

You can increase the signal range of the base unit by using a DECT repeater. Please use only the Panasonic DECT repeater noted on page 4. Contact your Panasonic dealer for details.

Programming

Important:

- Before registering the repeater to this base unit, you must turn the repeater mode on.
- Do not use more than one repeater at a time.

Setting the repeater mode

- 1 **[☐☐☐]** (right soft key) **#138**
- 2 **[↕]**: Select the desired setting. → **[OK]**
→ **[↻]**

Note:

- After turning the repeater mode on or off, **Y** may be displayed on the handset momentarily. This is normal and the handset can be used once **Y** is displayed.

Registering the DECT repeater (KX-A405) to the base unit

Note:

- Please use a repeater that has not yet been registered to another unit. If the repeater is registered to another unit, deregister it first, referring to the Installation Guide for the DECT repeater.

- 1 **Base unit:**
Press and hold **[•••]** for about 5 seconds, until the registration tone sounds.
 - The next step must be completed within 90 seconds.
- 2 **DECT repeater:**
Connect the AC adaptor, then wait until the **①** indicator and **Y** indicator light green.
- 3 **Base unit:**
To exit the registration mode, press **[•••]**.
 - The registration tone stops.

Using Caller ID service

Important:

- This unit is Caller ID compatible. To use Caller ID features, you must subscribe to Caller ID service. Contact your service provider/telephone company for details.
- For all local and national incoming calls, your display will show the area code (e.g. 09 for Auckland) or the cellular prefix (e.g. 0274 for Telecom Cellular) followed by the caller's telephone number. An Auckland caller's number will be displayed as 09XXXXXXXX. The seven X's represent the seven digits of the caller's telephone number. A caller from a 6-digit Telecom Cellular number will be displayed as 0274XXXXXXXX. For incoming international calls, your display may only show "0000". For business users on a Centrex line, your display will show Centrex extension numbers in the shorter extension number format used within your company.
- The Caller ID information will not be presented on incoming fax calls if Telecom FaxAbility is used.

Using toll services from Telecom or another company

Your telephone company may charge you for a local call if the number dialled has the area code prefix included. If this is unacceptable, dial only the 7-digit local number. Do not dial the [0] prefix or the area code.

Caller ID features

When an outside call is being received, the caller information is displayed.

Caller information for the last 50 callers is logged in the caller list from the most recent call to the oldest.

- If the unit cannot receive caller information, the following is displayed:
 - **"Out of Area"**: The caller dials from an area which does not provide a Caller ID service.
 - **"Private Caller"**: The caller requests not to send caller information.

- If the unit is connected to a PBX system, caller information may not be properly received. Contact your PBX supplier.

Missed calls

If a call is not answered, the unit treats it as a missed call and → is displayed. This lets you know if you should view the caller list to see who called while you were away.

Even if only one missed call in the caller list is viewed (page 31), → disappears from the display. When you receive another new call, → is displayed again.

Note:

- Even when there are unviewed missed calls, → disappears from the standby display if the following operation is performed by one of the registered handsets:
 - Being replaced on the base unit or charger.
 - Pressing [↵].

Phonebook name display

When caller information is received and it matches a phone number stored in the phonebook, the stored name in the phonebook is displayed and logged in the caller list.

Caller list

Important:

- Only 1 person can access the caller list at a time.
- Make sure the unit's date and time setting is correct (page 14).

Viewing the caller list and calling back

1 [↵] (→)

Caller ID Service

- 2 Press **[v]** to search from the most recent call, or press **[▲]** to search from the oldest call.
 - You can see the detailed information about the caller by pressing **[≡▪]** when in multiple display mode.
- 3 To call back, press **[↶]**.
To exit, press **[✕]**.

Note:

- If the entry has already been viewed or answered, “✓” is displayed, even if it was viewed or answered using another handset.
- If the call matches an entry in the call barred list, the number is logged with **☒** (page 27).
- If you do not want to dial the area code when making calls from the caller list, you can store the area code which you want the unit to delete automatically (page 28).

Editing a caller's phone number before calling back

The caller's telephone number, which is sent to your telephone from your local telephone exchange, includes “0” and an area code prefix. For local calls, “0” and the area code prefix can be omitted.

- 1 **[v]** (→)
- 2 **[↕]**: Select the desired entry. → **[≡▪]**
- 3 **[≡▪]** → **[↕]**: “Edit” → **[OK]**
- 4 Edit the number.
 - Press dial key (**[0]** to **[9]**) to add, **[C]** to delete.
- 5 **[↶]**

Erasing selected caller information

- 1 **[v]** (→)
- 2 **[↕]**: Select the desired entry.
- 3 **[✕]** → **[↕]**: “Yes” → **[OK]** → **[✕]**

Erasing all caller information

- 1 **[v]** (→)
- 2 **[✕]** → **[↕]**: “Yes” → **[OK]** → **[✕]**

Storing caller information to the phonebook

- 1 **[v]** (→)
- 2 **[↕]**: Select the desired entry. → **[≡▪]** → **[≡▪]**
- 3 **[↕]**: “Save CID” → **[OK]**
- 4 **[↕]**: “Phonebook” → **[OK]**
- 5 To store the name, continue from step 3, “Adding entries”, page 18.

Answering system

The answering system can answer and record calls for you when you are unavailable to answer the phone.

You can also set the unit to play a greeting message but not to record caller messages by selecting “**Greeting Only**” as the recording time setting (page 37).

Important:

- Only 1 person can access the answering system (listen to messages, record a greeting message, etc.) at a time.
- When callers leave messages, the unit records the day and time of each message. Make sure the date and time have been set correctly (page 14).
- The unit’s answering system will not answer incoming calls on your FaxAbility number.

Memory capacity (including your greeting message)

The total recording capacity is about 18 minutes. A maximum of 64 messages can be recorded.

Note:

- When message memory becomes full:
 - “**Messages Full**” is shown on the handset display.
 - The answer on indicator on the base unit flashes rapidly if the answering system is turned on.
 -  and the total number of new messages are not displayed on the handset even if the answering system is turned on.
 - If you use the pre-recorded greeting message, the unit automatically switches to another pre-recorded greeting message asking callers to call again later.
 - If you recorded your own greeting message, the same message is still announced to callers even though their messages are not recorded.

Turning the answering system on/off



The answering system is preset to on.

Base unit

Press  to turn on/off the answering system.

- When the answering system is turned on, the answer on indicator lights up.

Handset

- To turn on:**
 (right soft key) **# 3 2 7**
To turn off:
 (right soft key) **# 3 2 8**



2

Note:

- When the answering system is turned on,  is displayed next to the battery icon.

Call screening

While a caller is leaving a message, you can listen to the call through the handset’s speaker. To adjust the speaker volume, press **[▲]** or **[▼]** repeatedly. You can answer the call by pressing  on the handset. Call screening can be set for each handset. The default setting is “on”.

-  (right soft key) # 3 1 0**
- [↕]:** Select the desired setting. → **[OK]**
→ ****

Greeting message

When the unit answers a call, a greeting message is played to callers.

You can use either:

- your own greeting message
- a pre-recorded greeting message

Recording your greeting message

-  (right soft key) # 3 0 2**

Answering System

- 2 [↕]: “Yes” → [OK]
- 3 After a beep sounds, hold the handset about 20 cm away and speak clearly into the microphone (2 minutes and 30 seconds max.).
- 4 Press [■] to stop recording.
- 5 [📞]

Using a pre-recorded greeting message

The unit provides 2 pre-recorded greeting messages:

- If you erase or do not record your own greeting message, the unit plays a pre-recorded greeting asking callers to leave a message.
- If the message recording time (page 37) is set to “Greeting Only”, callers’ messages are not recorded and the unit plays a different pre-recorded greeting message asking callers to call again.

Resetting to a pre-recorded greeting message

If you want to use a pre-recorded greeting message once you record your own greeting message, you need to erase your own greeting message.

- 1 [☒] (right soft key) [#][3][0][4]
- 2 [OK] → [📞]

Playing back the greeting message

- 1 [☒] (right soft key) [#][3][0][3]
- 2 [📞]

Listening to messages using the base unit

When new messages have been recorded, [▶■] on the base unit flashes. Press [▶■].

- If new messages have been recorded, the base unit plays back new messages.
- If there are no new messages, the base unit plays back all messages.

Operating the answering system during playback

Key	Operation
[+] or [-]	Adjust the speaker volume
[⏮]	Repeat message*1
[⏭]	Skip message
[▶■]	Stop playback
[X]	Erase currently playing message

*1 If pressed within the first 5 seconds of a message, the previous message is played.

Erasing all messages

Press [X] 2 times while the unit is not in use.

Listening to messages using the handset

When new messages have been recorded, [☒] is displayed on the handset with the total number of new messages.

- 1 **To listen to new messages:**
[☒] (right soft key) [#][3][2][3]
To listen to all messages:
[☒] (right soft key) [#][3][2][4]
- 2 When finished, press [📞].

Note:

- To switch to the receiver, press [📞].

Listening to messages from the message list

You can select the item to play back.

- 1 [☒] (right soft key) [#][3][2][9]

Answering System

- 2** [**↓**]: Select the desired item from the message list. → [**▶**]
- You can erase the selected message as follows:
[**☐**] → [**↓**]: “Erase” → [**OK**] → [**↓**]: “Yes” → [**OK**]
- 3** When finished, press [**↶**].

Note:

- If the item has already been heard, “✓” is displayed, even if it was heard using another handset.
- “Message” is displayed in the message list if the unit cannot receive caller information.

Operating the answering system

[**☐**] (right soft key) → [**☐**] → [**OK**]

Key	Operation
[▲] or [▼]	Adjust the receiver or speaker volume (during playback)
[1] or [←]	Repeat message (during playback)*1
[2] or [▶]	Skip message (during playback)*2
[3]	Enter the “Settings” menu
[4]	Play new messages
[5]	Play all messages
[6]	Play greeting message
[7][6]	Record greeting message
[8]	Turn answering system on
[☐]	Pause message*3
[9] or [■]	Stop recording Stop playback
[0]	Turn answering system off
[*][4]*4	Erase currently playing message
[*][5]	Erase all messages
[*][6]	Reset to a pre-recorded greeting message

- *1 If pressed within the first 5 seconds of a message, the previous message is played except when playing back from the message list.
- *2 When you play a message from the message list, the unit stops message playback and the display goes back to the message list.
- *3 To resume playback:
[**↓**]: “Play” → [**OK**]
- *4 You can also erase as follows:
[**☐**] → [**↓**]: “Erase” → [**OK**] → [**↓**]: “Yes” → [**OK**]

Calling back (Caller ID subscribers only)

If caller information is received for the call, you can call the caller back while listening to a message.

- Press [**☐**] during playback.
- [**↓**]: “Call Back” → [**OK**]

Editing the number before calling back

- Press [**☐**] during playback.
- [**↓**]: “Edit & call” → [**OK**]
- Edit the number. → [**↶**]

Erasing all messages

- [**☐**] (right soft key) # [**3**] [**2**] [**5**]
- [**↓**]: “Yes” → [**OK**] → [**↶**]

Remote operation

Using a touch-tone phone, you can call your phone number from outside and access the unit to listen to messages or change answering system settings. The unit’s voice guidance prompts you to press certain dial keys to perform different operations.

Answering System

Remote access code

A 3-digit remote access code must be entered when operating the answering system remotely. This code prevents unauthorised parties from listening to your messages remotely.

Important:

- In order to operate the answering system remotely, you must first set a remote access code.

- 1 **[☐☐☐]** (right soft key) **#** **[3]** **[0]** **[6]**
- 2 To turn on remote operation, enter the desired 3-digit remote access code.
- 3 **[OK]** → **[🔊📞]**

Deactivating remote operation

Press **[✕]** in step 2 on "Remote access code" page 36.

- The entered remote access code is deleted.

Using the answering system remotely

- 1 Dial your phone number from a touch-tone phone.
- 2 After the greeting message starts, enter your remote access code.
- 3 Follow the voice guidance prompts as necessary or control the unit using remote commands (page 36).
- 4 When finished, hang up.

Voice guidance

During remote operation, the unit's voice guidance starts and prompts you to press **[1]** to perform a specific operation, or press **[2]** to listen to more available operations.

Note:

- If you do not press any dial keys within 10 seconds after a voice guidance prompt, the unit disconnects your call.

Remote commands

You can press dial keys to access certain answering system functions without waiting for the voice guidance to prompt you.

Key	Operation
[1]	Repeat message (during playback)*1
[2]	Skip message (during playback)
[4]	Play new messages
[5]	Play all messages
[6]	Play greeting message
[7]	Record greeting message
[9]	Stop recording Stop playback
[0]	Turn answering system off
[✕][4]	Erase currently playing message
[✕][5]	Erase all messages
[✕][6]	Reset to a pre-recorded greeting message (during greeting message playback)
[✕][#]	End remote operation (or hang up)

*1 If pressed within the first 5 seconds of a message, the previous message is played.

Turning on the answering system remotely

If the answering system is off, you can turn it on remotely.

- 1 Dial your phone number from a touch-tone phone.
- 2 Let the phone ring 15 times.
 - A long beep is heard.
- 3 Enter your remote access code within 10 seconds after the long beep.
 - The greeting message is played back.
 - You can either hang up, or enter your remote access code again and begin remote operation (page 35).

Answering system settings

Number of rings before the unit answers a call

You can change the number of times the phone rings “**Number of Rings**” before the unit answers a call. You can select 2 to 9 rings, or “**Auto**”.

The default setting is “**5 Rings**”.

“**Auto**”: The unit’s answering system answers at the end of the 2nd ring when new messages have been recorded, or at the end of the 5th ring when there are no new messages. If you call your phone from outside to listen to new messages (page 36), you know that there are no new messages when the phone rings for the 3rd time. You can then hang up without being charged for the call.

- 1 [☐] (right soft key) [#]2[1]1
- 2 [↕]: Select the desired setting. → [OK]
→ [🔇]

For Telecom Call Minder or TelstraClear Message Mailbox service subscribers

To receive Call Minder or Message Mailbox messages and use the unit’s answering system properly, please note the following:

- “Call Minder” and “Message Mailbox” are services provided by your service provider/telephone company (page 38). You will need to first subscribe or activate this service through your service provider/telephone company. Contact your service provider/telephone company on how to operate this service and how you will be notified that you have messages. To use this service you will be required to leave your answering machine off on your unit (page 33). This will allow the service to receive any messages.
- To use the unit’s answering machine rather than the service provided by your service provider/telephone company, please contact your service provider/telephone company to have it removed or deactivated

permanently or temporarily. Alternatively you can leave this service connected and change the “**Number of Rings**” to a shorter duration on your unit so your unit’s answering machine can pick up the call prior to the service provided by your service provider/telephone company.

Caller’s recording time

You can change the maximum message recording time allowed for each caller. The default setting is “**3 Minutes**”.

- 1 [☐] (right soft key) [#]3[0]5
- 2 [↕]: Select the desired setting. → [OK]
→ [🔇]

Selecting “Greeting Only”

You can select “**Greeting Only**” which sets the unit to announce a greeting message to callers but not record messages.

Select “**Greeting Only**” in step 2 on “Caller’s recording time” page 37.

Note:



- When you select “**Greeting Only**”:
 - If you do not record your own message, the unit will play the pre-recorded greeting-only message asking callers to call again later.
 - If you use your own message, record the greeting-only message asking callers to call again later (page 33).

Voice Mail Service

Voice mail service

To receive Call Minder or Message Mailbox messages, please note the following: “Call Minder” and “Message Mailbox” are automatic answering services offered by your service provider/telephone company. After you subscribe to this service, your service provider/telephone company’s voice mail system answers calls for you when you are unavailable to answer the phone or when your line is busy. Messages are recorded by your service provider/telephone company, not your telephone. When you have new messages,  is displayed on the handset if message indication service is available. Please contact your service provider/telephone company for details of this service.

Important:

- If  still remains on the display even after you have listened to new messages, turn it off by pressing and holding  for 2 seconds.
- To use the voice mail service provided by your service provider/telephone company rather than the unit’s answering system, turn off the answering system (page 33). For details, see page 37.

Intercom

Intercom calls can be made between handsets.

Note:

- When paging the handset, the paged handset beeps for 1 minute.
- If you receive an outside call while talking on the intercom, you hear 2 tones. To answer the call, press **[*0]**, then press **[↶]**.

Making an intercom call

- 1 **[☐]** (right soft key) → **[*])**
- 2 **[↕]**: Select the desired unit. → **[OK]**
 - To stop paging, press **[*0]**.
- 3 When you finish talking, press **[*0]**.

Answering an intercom call

- 1 Press **[↶]** to answer the page.
- 2 When you finish talking, press **[*0]**.

Handset locator

You can locate a misplaced handset by paging it.

- 1 **Base unit:** Press **[*])**.
 - All registered handsets beep for 1 minute.
- 2 To stop paging:
 - Base unit:** Press **[*])**.
 - Handset:** Press **[*0]**.

Transferring calls, conference calls

Outside calls can be transferred or a conference call with an outside party can be made between 2 handsets.

- 1 During an outside call, press **[☐]** to put the call on hold.

- 2 **[↕]**: "Intercom" → **[OK]**
- 3 **[↕]**: Select the desired unit. → **[OK]**
- 4 Wait for the paged party to answer.
 - If the paged party does not answer, press **[↶]** to return to the outside call.
- 5 **To complete the transfer:**
Press **[*0]**.
 - The outside call is being routed to the destination unit.**To establish a conference call:**
[☐] → **[↕]**: "Conference" → **[OK]**
 - To leave the conference, press **[*0]**. The other 2 parties can continue the conversation.
 - To put the outside call on hold: **[☐]** → **[↕]**: "Hold" → **[OK]**
To resume the conference: **[☐]** → **[↕]**: "Conference" → **[OK]**
 - To cancel the conference: **[☐]** → **[↕]**: "Stop Conference" → **[OK]**
You can continue the conversation with the outside caller.

Answering a transferred call

Press **[↶]** to answer the page.

Useful Information

Character entry

The dial keys are used to enter characters and numbers. Each dial key has multiple characters assigned to it. The characters that can be entered depend on the character entry mode (page 40).

- Press [◀] or [▶] to move the cursor left or right.
- Press dial keys to enter characters and numbers.
- Press [C] to erase the character or number highlighted by the cursor. Press and hold [C] to erase all characters or numbers.
- Press [A→a] to switch between uppercase and lowercase.
- To enter another character located on the same dial key, press [▶] to move the cursor to the next space, then press the appropriate dial key.
- If you do not press any dial key within 5 seconds after entering a character, the character is fixed and the cursor moves to the next space.

Character entry modes

The available character entry modes are Alphabet (ABC), Numeric (0-9), Greek (ABΓ), Extended 1 (AÄÅ), Extended 2 (ŠŠŠ), and Cyrillic (AБВ). When in these entry modes except Numeric, you can select which character is entered by pressing a dial key repeatedly.

When the unit displays the character entry screen:

[R/ECO] → [↕]: Select a character entry mode. → [OK]

Note:

- ◻ in the following tables represents a single space.

Alphabet character table (ABC)

0	1	2	3	4	5	6	7	8	9	#
◻ 0	& ' () * , - . / 1	A B C 2	D E F 3	G H I 4	J K L 5	M N O 6	P Q R S 7	T U V 8	W X Y Z 9	#
		a b c 2	d e f 3	g h i 4	j k l 5	m n o 6	p q r s 7	t u v 8	w x y z 9	

Numeric entry table (0-9)

0	1	2	3	4	5	6	7	8	9	#
0	1	2	3	4	5	6	7	8	9	#

Greek character table (ABΓ)

0	1	2	3	4	5	6	7	8	9	#
◻ 0	& ' () * , - . / 1	A B Γ 2	Δ E Z 3	H Θ I 4	K Λ M 5	N Ξ O 6	Π Ρ Σ 7	T Υ Φ 8	X Ψ Ω 9	#

Useful Information

Extended 1 character table (AĂÄ)

0	1	2	3	4	5	6	7	8	9	#
└ 0	& ' () * , - . / 1	A Ä Á Å Æ B C Ç 2	D E È É Ê Ë F 3	G Ğ H I Ì Í Î Ï 4	J K L 5	M N Ñ O Ö Ó Ô Õ Ö ø 6	P Q R S Ş ß 7	T U Û Ü Ü Ü Û V 8	W Ŵ X Ý ŷ Z 9	#
		a à á â ã ä å æ b c ç 2	d e è é ê ë f 3	g ğ h i ì í î ï 4	j k l 5	m n ñ o ò ó ô õ ö ø 6	p q r s ş ş ß 7	t u ù ú û ü ü v 8	w ŵ x ý ŷ z 9	

- The following are used for both uppercase and lowercase: ø Ŵ ŷ

Extended 2 character table (ŠŠŠ)

0	1	2	3	4	5	6	7	8	9	#
└ 0	& ' () * , - . / 1	A Ā Ā Ą B C Ć Ć 2	D Ď E É Ę Ě F 3	G Ħ I Í 4	J K L Ł Ł Ł 5	M N Ń Ń Ń Ń Ō Ō 6	P Q R Ŕ Ŕ Ŕ Ś Ś 7	T Ŧ U Ú Ů Ů ú v 8	W X Y Ý Ź Z 9	#
		a ā ä ą b c ć ć 2	d ě e é ę ě f 3	g ħ i í 4	j k l ł ł ł ł 5	m n ń ń ń ń ō ō 6	p q r ŕ ŕ ŕ ś ś 7	t ŧ u ú ů ů ú v 8	w x y ý ź z 9	

- The following are used for both uppercase and lowercase:

Ą Ć Ć Ę Ł Ł Ł Ń Ń Ń Ů Ů Ů Ź Ź Ź

Cyrillic character table (АБВ)

0	1	2	3	4	5	6	7	8	9	#
└ 0 Ą Є І і ÿ	& ' () * , - . / 1	А Б В Г 2	Д Е Ж З 3	И Й К Л 4	М Н О П 5	Р С Т У 6	Ф Х Ц Ч 7	Ш Щ Ъ Ы 8	Ь Э Ю Я 9	#

Useful Information

Error messages

Display message	Cause/solution
Base no power or No link to base. Reconnect main base AC adaptor.	<ul style="list-style-type: none">• The handset has lost communication with the base unit. Move closer to the base unit and try again.• Unplug the base unit's AC adaptor to reset the unit. Reconnect the adaptor and try again.• The handset's registration may have been cancelled. Re-register the handset (page 29).
Check Phone Line	<ul style="list-style-type: none">• The supplied telephone line cord has not been connected yet or not connected properly. Check the connections (page 9).
Error	<ul style="list-style-type: none">• Recording was too short. Try again.
Memory Full	<ul style="list-style-type: none">• The phonebook memory is full. Erase unwanted entries (page 18).• Message memory is full. Erase unwanted messages (page 34, 35).• The call barred list memory is full. Erase unwanted entries (page 28).
Use rechargeable battery.	<ul style="list-style-type: none">• A wrong type of battery such as Alkaline or Manganese was inserted. Use only the rechargeable Ni-MH batteries noted on page 4, 6.
You must first subscribe to Caller ID.	<ul style="list-style-type: none">• You must subscribe to a Caller ID service. Once you receive caller information after subscribing to a Caller ID service, this message will not be displayed.

Troubleshooting

If you still have difficulties after following the instructions in this section, disconnect the base unit's AC adaptor and turn off the handset, then reconnect the base unit's AC adaptor and turn on the handset.

General use

Problem	Cause/solution
The handset does not turn on even after installing charged batteries.	<ul style="list-style-type: none"> Place the handset on the base unit or charger to turn on the handset.
The unit does not work.	<ul style="list-style-type: none"> Make sure the batteries are installed correctly (page 9). Fully charge the batteries (page 10). Check the connections (page 9). Unplug the base unit's AC adaptor to reset the unit and turn off the handset. Reconnect the adaptor, turn on the handset and try again. The handset has not been registered to the base unit. Register the handset (page 29).
The handset display is blank or dark.	<ul style="list-style-type: none"> The handset is in screen saver mode (page 13). Activate the handset display again by: <ul style="list-style-type: none"> pressing [↶] when on a call. pressing [✕] at all other times. "LCD in charging" is set to "off" while on charge. Change the setting (page 24). The handset is not turned on. Turn the power on (page 13).
I cannot hear a dial tone.	<ul style="list-style-type: none"> Make sure that you are using the supplied telephone line cord. Your old telephone line cord may have a different wiring configuration. The base unit's AC adaptor or telephone line cord is not connected. Check the connections. Disconnect the base unit from the telephone line and connect the line to a known working telephone. If the working telephone operates properly, contact our service personnel to have the unit repaired. If the working telephone does not operate properly, contact your service provider/telephone company.



Programmable settings

Problem	Cause/solution
The display is in a language I cannot read.	<ul style="list-style-type: none"> Change the display language (page 13).
I cannot activate the eco mode.	<ul style="list-style-type: none"> You cannot set eco mode when you set the repeater mode "on". If required, set the repeater mode to "off" (page 30).

Useful Information

Problem	Cause/solution
I cannot register a handset to a base unit.	<ul style="list-style-type: none">• The maximum number of handsets (6) is already registered to the base unit. Cancel unused handset registrations from the base unit (page 29).• You entered the wrong PIN. If you forget your PIN, contact an authorised service centre.

Battery recharge

Problem	Cause/solution
The handset beeps and/or  flashes.	<ul style="list-style-type: none">• Battery charge is low. Fully charge the batteries (page 10).
I fully charged the batteries, but <ul style="list-style-type: none">–  still flashes or– the operating time seems to be shorter.	<ul style="list-style-type: none">• Clean the battery ends (\oplus, \ominus) and the charge contacts with a dry cloth and charge again.• It is time to replace the batteries (page 9).

Making/answering calls, intercom

Problem	Cause/solution
 is displayed.	<ul style="list-style-type: none">• The handset is too far from the base unit. Move closer.• The base unit's AC adaptor is not properly connected. Reconnect AC adaptor to the base unit.• The handset is not registered to the base unit. Register it (page 29).• Activating one touch eco mode reduces the range of the base unit in standby mode. If required, turn eco mode off (page 14).
Noise is heard, sound cuts in and out.	<ul style="list-style-type: none">• You are using the handset or base unit in an area with high electrical interference. Re-position the base unit and use the handset away from sources of interference.• Move closer to the base unit.• If you use a DSL/ADSL (JetStream) service, we recommend that you contact your DSL/ADSL service provider to have a DSL/ADSL Splitter installed. We do not recommend the use of generic DSL/ADSL filters. Contact your DSL/ADSL service provider for details.
Sound quality seems to be getting worse.	<ul style="list-style-type: none">• You have registered a handset that is not recommended (page 4). The clearest sound quality is only possible by registering the recommended handset.
The handset does not ring.	<ul style="list-style-type: none">• The ringer volume is turned off. Adjust ringer volume (page 15, 23).• Night mode is turned on. Turn it off (page 27).
The base unit does not ring.	<ul style="list-style-type: none">• The ringer volume is turned off. Adjust ringer volume (page 23).

Useful Information

Problem	Cause/solution
I cannot make a call.	<ul style="list-style-type: none">● If you are using a BT double adaptor to connect the unit, remove the adaptor and connect the unit to the phone wall socket directly. If the unit operates properly, check or replace the adaptor.● You dialled a call restricted number (page 28).● The key lock feature is turned on. Turn it off (page 17).● The unit is not designed to be used with rotary/pulse dialling services.

Caller ID

Problem	Cause/solution
Caller information is not displayed.	<ul style="list-style-type: none">● You must subscribe to a Caller ID service. Contact your service provider/telephone company for details.● If your unit is connected to any additional telephone equipment, remove and plug the unit directly into the wall socket.● If you use a DSL/ADSL (JetStream) service, we recommend that you contact your DSL/ADSL service provider to have a DSL/ADSL Splitter installed. We do not recommend the use of generic DSL/ADSL filters. Contact your DSL/ADSL service provider for details.● Other telephone equipment such as a monitored Burglar Alarm or the modem in the SKY Digital decoder may be interfering with this unit. Disconnect the other equipment and try again.
Caller information is slow to display.	<ul style="list-style-type: none">● Depending on your service provider/telephone company, the unit may display the caller's information at the 2nd ring or later. Set the first ring to "O££" (page 23).● Move closer to the base unit.
Time on the unit has shifted.	<ul style="list-style-type: none">● Incorrect time information from incoming Caller ID changes the time. Set the time adjustment to "Manual1" (off) (page 23).

Answering system

Problem	Cause/solution
The unit does not record new messages.	<ul style="list-style-type: none">● The answering system is turned off. Turn it on (page 33).● The message memory is full. Erase unwanted messages (page 34).● The recording time is set to "Greeting Only". Change the setting (page 37).● If you subscribe to a voice mail service, messages are recorded by your service provider/telephone company, not your telephone. Change the unit's number of rings setting or contact your service provider/telephone company (page 37).

Useful Information

Problem	Cause/solution
I cannot operate the answering system remotely.	<ul style="list-style-type: none">• The remote access code is not set. Set the remote access code (page 36).• You are entering the wrong remote access code. If you have forgotten your remote access code, enter the remote access code setting to check your current code (page 36).• The answering system is turned off. Turn it on (page 36).
The unit does not emit the specified number of rings.	<ul style="list-style-type: none">• If the first ring is turned off, the number of rings decreases by 1 from the specified number of rings.

Liquid damage

Problem	Cause/solution
Liquid or other form of moisture has entered the handset/base unit.	<ul style="list-style-type: none">• Disconnect the AC adaptor and telephone line cord from the base unit. Remove the batteries from the handset and leave to dry for at least 3 days. After the handset/base unit are completely dry, reconnect the AC adaptor and telephone line cord. Insert the batteries and charge fully before use. If the unit does not work properly, contact an authorised service centre.

Caution:

- To avoid permanent damage, do not use a microwave oven to speed up the drying process.

Warranty

Panasonic New Zealand undertakes to:

Repair or at its option, replace without cost to the owner, either for material or labour, any part which is found to be defective within two years of the date of purchase.

THIS EXPRESS WARRANTY DOES NOT COVER:

- 1) Pick up and delivery.
- 2) Batteries.
- 3) Repairs when the product has not been used in accordance with the Operating Instructions Manual or has been modified.
- 4) Normal maintenance and cleaning as required in the product's Operating Instructions Manual.
- 5) Service calls to:
 - a Correct the set up of the product
 - b Instruct you how to use the product
 - c Replace fuses or correct your building's wiring
- 6) Damage to the product caused by accident, misuse or Act of God.
- 7) Repairs when the product has been dismantled, repaired, modified or serviced by other than a Panasonic Authorised Dealer authorised to service that type of product.

IF YOUR PANASONIC PRODUCT FAILS WITHIN THE WARRANTY PERIOD:

Take it to the Authorised Panasonic Dealer from whom you purchased the product who will repair it (or arrange to have it repaired) during their normal business hours. All enquiries regarding warranty or otherwise, please call – Customer Support Centre Tel. No.: (09) 272 0178

NOTE: THIS EXPRESS WARRANTY IS OFFERED AS AN EXTRA BENEFIT AND DOES NOT AFFECT YOUR LEGAL RIGHTS.

Index

Index

- A** Additional handsets: 29
 - Alarm: 26
 - Answering calls: 15
 - Answering system: 33
 - Call screening: 33
 - Erasing messages: 34, 35, 36
 - Greeting message: 33
 - Greeting only: 37
 - Listening to messages: 34, 36
 - Message list: 34
 - Number of rings: 37
 - Recording time: 37
 - Remote access code: 36
 - Remote operation: 35
 - Turning on/off: 33
 - Area code: 28
 - Auto talk: 15, 24
- B** Battery: 9, 10
- C** Call restriction: 28
 - Call share: 17
 - Call Waiting: 16
 - Call Waiting Caller ID: 16
 - Caller ID service: 31
 - Caller list: 31
 - Caller list edit: 32
 - Chain dial: 19
 - Character entry: 40
 - Conference calls: 39
 - Control type: 11
- D** Date and time: 14
 - Direct command code: 21
 - Display
 - Clock: 24
 - Colour: 24
 - Contrast: 24
 - Display mode: 14
 - Language: 13
 - LCD backlight: 24
 - Wallpaper: 24
- E** Eco mode: 14
 - Equalizer: 16
 - Error messages: 42
- F** First ring: 23
- H** Handset
 - Deregistration: 29
 - Locator: 39
 - Name: 27
 - Registration: 29
 - Hold: 16
- I** Incoming call barring: 27
 - Intercom: 39
- K** Key finder: 23, 25
 - Key lock: 17
 - Keytones: 24
- M** Making calls: 15
 - Missed calls: 31
 - Mute: 16
- N** Night mode: 27
 - Noise reduction: 16
- P** Pause: 15
 - Phonebook: 18
 - PIN: 29
 - Power failure: 10
 - Power on/off: 13
 - Privacy mode: 24
- R** Recall/flash: 16
 - Redialling: 15
 - Repeater: 29
 - Ringer tone: 23
- S** Speakerphone: 15
 - Speed dial: 20
- T** Time adjustment: 23
 - Transferring calls: 39
 - Troubleshooting: 43
- V** Voice mail: 38
 - Volume
 - Receiver: 15
 - Ringer (Base unit): 23
 - Ringer (Handset): 15, 23
 - Speaker: 15

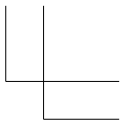
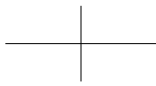
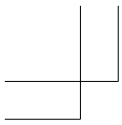

Notes

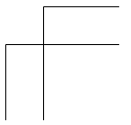
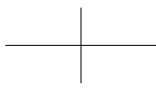
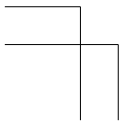
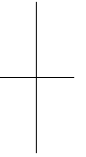
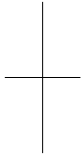

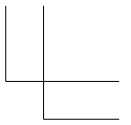
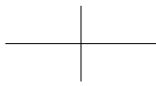
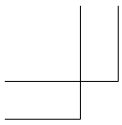

Notes

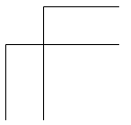
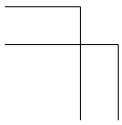
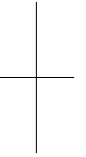
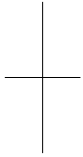

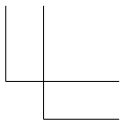
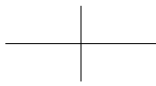
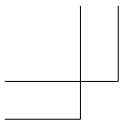

Notes

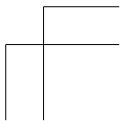
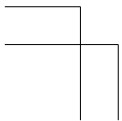
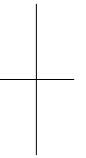
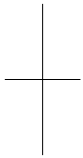

For your future reference

We recommend keeping a record of the following information to assist with any repair under warranty.

Serial No. (found on the bottom of the base unit)	Date of purchase
Name and address of dealer	



Customer Care Centre Tel. No.: (09) 272 0178 or website www.panasonic.co.nz

Sales Department:

Panasonic New Zealand Ltd.

350 Te Irirangi Drive, East Tamaki, Private Bag 14911 Panmure, Auckland, New Zealand

Phone: (09) 272 0100

Fax: (09) 272 0137

Panasonic System Networks Co., Ltd.

1-62, 4-chome, Minoshima, Hakata-ku, Fukuoka 812-8531, Japan

© Panasonic System Networks Co., Ltd. 2013



PNQX5890ZA

PNQX5890ZA TT0113YK0 (E)