

# Panasonic<sup>®</sup>

## Installation Guide

---

### Home Network System Indoor Siren

Model No. **KX-HNS105AZ**



**Thank you for purchasing a Panasonic product.**

This document explains how to install the indoor siren properly.  
For details about how to use the system, refer to the User's Guide  
(page 13).

Please read this document before using the unit and save it for future reference.

## ***Table of Contents***

---

### **Introduction**

Accessory information .....	3
-----------------------------	---

### **Important Information**

About this system .....	4
For your safety .....	4
Important safety instructions .....	6
For best performance .....	6
Other information .....	6

### **Setup**

Part names and functions .....	8
LED indicator .....	8
Setup overview .....	8
Registering the siren .....	9
Confirming the usage area .....	10
Installation .....	10
Note about power connections .....	12

### **Appendix**

Testing the siren .....	13
Adjusting the siren's volume .....	13
Features available when using the [Home Network] app .....	13
Accessing the User's Guide .....	13
Specifications .....	14
Warranty (for New Zealand) .....	15

---

## Accessory information

---

### Supplied accessories

No.	Accessory item/Part number	Quantity
①	AC adaptor/PNLV236AL	1
②	DC extension cord	1
③	Wall mounting screws (25 mm)	2

①



②



③



---

### Other information

- Design and specifications are subject to change without notice.
- The illustrations in these instructions may vary slightly from the actual product.

---

### Trademarks

- iPhone and iPad are trademarks of Apple Inc., registered in the U.S. and other countries.
- Android is a trademark of Google Inc.
- Microsoft, Windows, and Internet Explorer are either registered trademarks or trademarks of Microsoft Corporation in the United States and/or other countries.
- All other trademarks identified herein are the property of their respective owners.

### About this system

- This system is an auxiliary system; it is not designed to provide complete protection from property loss. Panasonic will not be held responsible in the event that property loss occurs while this system is in operation.
- The system's wireless features are subject to interference, therefore functionality in all situations cannot be guaranteed. Panasonic will not be held responsible for injury or damage to property that occurs in the event of wireless communication error or failure.

### For your safety

To prevent severe injury and loss of life/property, read this section carefully before using the product to ensure proper and safe operation of your product.



#### WARNING

##### Power connection

- Use only the power source marked on the product.
- Do not overload power outlets and extension cords. This can result in the risk of fire or electric shock.
- Completely insert the AC adaptor/power plug into the power outlet. Failure to do so may cause electric shock and/or excessive heat resulting in a fire.
- Regularly remove any dust, etc. from the AC adaptor/power plug by pulling it from the power outlet, then

wiping with a dry cloth. Accumulated dust may cause an insulation defect from moisture, etc. resulting in a fire.

- Unplug the product from power outlets if it emits smoke, an abnormal smell, or makes an unusual noise. These conditions can cause fire or electric shock. Confirm that smoke has stopped emitting and contact an authorised service centre.
- Unplug from power outlets and never touch the inside of the product if its casing has been broken open. Danger of electric shock exists.
- Never touch the plug with wet hands. Danger of electric shock exists.
- Do not connect non-specified devices.

##### Installation

- To prevent the risk of fire or electrical shock, do not expose the product to rain or any type of moisture.
- Do not place or use this product near automatically controlled devices such as automatic doors and fire alarms. Radio waves emitted from this product may cause such devices to malfunction resulting in an accident.
- Do not allow the AC adaptor to be excessively pulled, bent or placed under heavy objects.
- Install the product only on a vertical surface. Do not install the product on a ceiling, as the product may fall, resulting in damage or injury.
- Keep small parts (screws, etc.) out of the reach of children. There is a risk of swallowing. In the event they are swallowed, seek medical advice immediately.

- It is advised not to use the equipment at a refuelling point. Users are reminded to observe restrictions on the use of radio equipment in fuel depots, chemical plants or where blasting operations are in progress.

### Operating safeguards

- Unplug the product from power outlets before cleaning. Do not use liquid or aerosol cleaners.
- Do not disassemble the product.
- Never put metal objects inside the product. If metal objects enter the product, turn off the circuit breaker and contact an authorised service centre.

### Medical

- Consult the manufacturer of any personal medical devices, such as pacemakers or hearing aids, to determine if they are adequately shielded from external RF (radio frequency) energy. DECT features operate between 1.88 GHz and 1.90 GHz with a peak transmission power of 250 mW.
- Do not use the product in health care facilities if any regulations posted in the area instruct you not to do so. Hospitals or health care facilities may be using equipment that could be sensitive to external RF energy.

### CAUTION

### Installation and location

- Never install wiring during a lightning storm.

- The AC adaptor is used as the main disconnect device. Ensure that the AC outlet is installed near the product and is easily accessible.
- To avoid the risk of strangulation, keep the product and the AC adaptor cord at least 1 m from a child's crib and out of the reach of small children.

### Preventing accidents and injuries

- Do not put your ear(s) near the product, as loud sounds emitted from the product may cause hearing impairment.
- Do not look directly at the strobe light when it is flashing. Light emitted from the strobe light may cause damage to the eyes.
- Consider the installation environment carefully when installing the product. Pay particular attention to infants, children, and the elderly, as they may be more sensitive to loud sounds and strobe lights.

### General notices

- This equipment will be inoperable when mains power fails.
- When a failure occurs which results in the internal parts becoming accessible, disconnect the power supply cord immediately and return this unit to an authorised service centre.
- To minimise the possibility of lightning damage, when you know that a thunderstorm is coming, we recommend that you unplug the AC adaptor from the AC power outlet.

### Important safety instructions

When using your product, basic safety precautions should always be followed to reduce the risk of fire, electric shock, and injury to persons, including the following:

1. Do not use this product near water for example, near a bathtub, washbowl, kitchen sink, or laundry tub, in a wet basement or near a swimming pool.
2. Use only the power cord indicated in this document.

### SAVE THESE INSTRUCTIONS

---

## For best performance

---

### Hub location/avoiding noise

The hub and other compatible Panasonic devices use radio waves to communicate with each other.

- For maximum coverage and noise-free communications, place your hub:
  - at a convenient, high, and central location with no obstructions between the product and hub in an indoor environment.
  - away from electronic appliances such as TVs, radios, personal computers, wireless devices, or other phones.
  - facing away from radio frequency transmitters, such as external antennas of mobile phone cell stations. (Avoid putting the hub on a bay window or near a window.)

- If the reception for a hub location is not satisfactory, move the hub to another location for better reception.

### Environment

---

- Keep the product away from electrical noise generating devices, such as fluorescent lamps and motors.
- The product should be kept free from excessive smoke, dust, high temperature, and vibration.
- The product should not be exposed to direct sunlight.
- Do not place heavy objects on top of the product.
- When you leave the product unused for a long period of time, unplug the product from the power outlet.
- The product should be kept away from heat sources such as radiators, cookers, etc. It should not be placed in rooms where the temperature is less than 0 °C or greater than 40 °C. Damp basements should also be avoided.
- Operating the product near electrical appliances may cause interference. Move away from the electrical appliances.

## Other information

---

### Routine care

- Wipe the outer surface of the product with a soft moist cloth.
- Do not use benzine, thinner, or any abrasive powder.

### Information on Disposal in other Countries outside the European Union



These symbols are only valid in the European Union. If you wish to discard these items, please contact your local authorities or dealer and ask for the correct method of disposal.

### Part names and functions

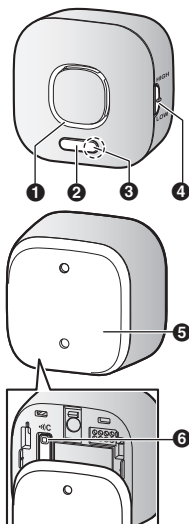

- 1** Horn
- 2** Strobe light  
Flashes when the siren is sounding.
- 3** LED indicator
- 4** [HIGH]/[LOW]  
Used to adjust the siren's volume (page 13).
- 5** Rear cover
- 6** [••)C]  
Used to register the siren to the hub.

### LED indicator

You can use the LED indicator to confirm the siren's status.

Indicator	Status
Green, lit	Normal operation
Red, blinking slowly	Siren is not registered to a hub
Red, blinking	Siren is out of range of the hub
Red, blinking quickly	Alarm system was triggered
Green, blinking slowly	Registration mode (You pressed and held [••)C])
Off	No power

### Setup overview

- 1 Initial setup**  
Make sure you can access the system using your mobile device. For details, refer to the System Setup Guide included with your hub.
- 2 Registration**  
Required only if the siren was purchased separately (i.e., not as part of a bundle).
- 3 Confirm the installation area**  
Read the information in this document to confirm that the desired installation area is suitable to proper operation.



## 4 Installation

Install the siren in the desired location.

---

## Registering the siren

This procedure is not required for devices that were included as part of a bundle.

Before you can use the siren, it must be registered to the hub.

If you purchased devices separately (i.e., not as part of a bundle), you must register each device to the hub.

You can register each device by using the registration buttons or the **[Home Network]** app.

### Note:

- Before registering the siren, make sure the AC adaptors of the hub and siren are connected and each device is powered.

---

## Using registration buttons

### 1 Hub:

Press and hold **[•)C OTHER DEVICE]** until the LED indicator blinks slowly in green.

### 2 Siren:

Press and hold **[•)C]** until the LED indicator blinks slowly in green (page 8).

- When registration is complete, the hub sounds one long beep.

### Note:

- To cancel without registering the siren, press **[•)C]** on the hub and on the siren again.

- If registration fails, the hub sounds several short beeps.

---

## Using the app

When you register the siren by using the **[Home Network]** app, you can assign a name to your devices and group them by location. For more information, refer to the User's Guide (page 13).

# Confirming the usage area

---

## Wireless communication range

The wireless communication range of each device in the system from the hub is approximately 50 m indoors and approximately 300 m outdoors.

Wireless communication may be unreliable when the following obstacles are located between the hub and other devices.

- Metal doors or screens
- Walls containing aluminium-sheet insulation
- Walls made of concrete or corrugated iron
- Double-pane glass windows
- Multiple walls
- When using each device on separate floors or in different buildings

### Note:

- You can use the siren's LED indicator to confirm the siren's communication status (page 8). If the LED indicator is lit in green or is blinking quickly in red, the siren is communicating properly with the hub.

## Usage area cautions

---

Using the siren in the following areas may cause deformation, malfunction, or operational failure.

- In direct sunlight
- Areas exposed to grease or steam, such as kitchens
- Near fire or heating devices

- Near magnetic fields (such as near microwaves and magnets)
- Areas subject to extreme temperature changes, such as next to air conditioners
- Areas with reflective objects, such as glass, that can interfere with detection of temperature variation
- Areas where the temperature is affected by strong illuminating objects (such as fluorescent lights)
- Near devices that emit strong radio waves, such as mobile phones

## Installation

---

Mount the siren on a wall using the holes in the rear cover.

### Note:

- The strobe light flashes when the siren sounds. Mount the siren in a location where its strobe light will be visible.
- Mount the siren on the stable location where the siren can be adequately supported when mounting.
- Mount the siren securely to a wall. Vibrations may cause it to fall if it is not secured.
- Do not mount siren on a soft material. It may fall down, break or cause injury.
- Do not mount the siren on the following places: gypsum board, ALC (autoclaved lightweight cellular concrete), concrete block, plywood less than 25.4 mm thick, etc.
- Use only the supplied Panasonic AC adaptor PNLV236AL.

- 1 Remove the rear cover by pressing the upper sides of the cover (1) and sliding it down (2).

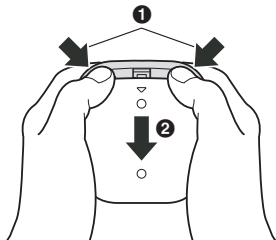

- 2 Attach the rear cover to the wall by using screws (A).
  - Place the rear cover with "UP" mark facing upwards.
  - B 37 mm

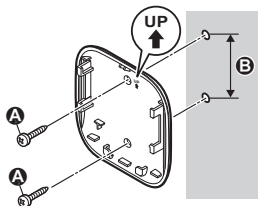
**Note:**

- Use the following template below when determining the location of the screw holes.

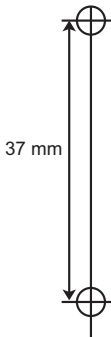

## Setup

- 3** Use the DC extension cord (①) to connect the AC adaptor (②) to the siren.
- Insert the male plug of the DC extension cord (③) firmly into the DC socket (④, ⑤).
  - Insert the female plug of the DC extension cord (⑥) firmly into the AC adaptor plug (⑦).
- 4** Connect the AC adaptor to the power outlet (⑧).

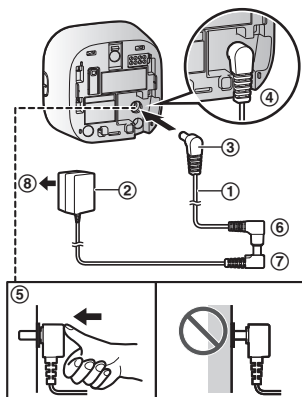

- 5** Attach the siren to the rear cover.
- Insert the grooves on the siren to the 4 tabs on the rear cover, and then push down the siren.

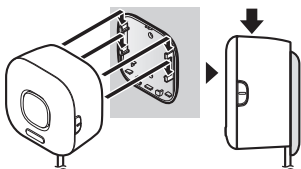

### Note:

While the siren is sounding or the strobe light is flashing, you can stop the siren by pressing **[••]C**.

## Note about power connections

### AC adaptor connection

- The AC adaptor must remain connected at all times. (It is normal for the adaptor to feel warm during use.)
- The AC adaptor should be connected to a vertically oriented or floor-mounted AC outlet. Do not connect the AC adaptor to a ceiling-mounted AC outlet, as the weight of the adaptor may cause it to become disconnected.

### Power failure

- The siren will not work during a power failure.

## Testing the siren

After you have installed the **[Home Network]** app on your mobile device, you can use your mobile device to test the siren. For more information, refer to the User's Guide (page 13).

- 1 Start the **[Home Network]** app, and tap **[Settings]**.
- 2 Tap **[Device Profiles]**.
- 3 Tap **[Siren]** and then select the desired siren.
- 4 Tap **[Installation Test]**.
- 5 Tap **[Play]**.

## Adjusting the siren's volume

You can adjust the siren's volume using the siren's **[HIGH]/[LOW]** switch (page 8).

## Features available when using the **[Home Network]** app

Some of the siren's features that are available when using the **[Home Network]** app are listed below. For more information, refer to the User's Guide (page 13).

### – Alarm system

You can use the app to arm and disarm the alarm system, confirm the current status of the system's devices, and view a log of previous events. You can also use the app to stop the siren from sounding.

### – Device management

You can use the app to confirm the wireless signal strength of the siren, change the siren's name, change whether the siren sounds, flashes, or both, and test the siren.

## Accessing the User's Guide

The User's Guide is a collection of online documentation that helps you get the most out of the **[Home Network]** app.

### 1 iPhone/iPad

Tap  in the app's home screen.

### Android™ devices

Tap  or press your mobile device's menu button in the app's home screen.

### 2 Tap **[User's Guide]**.

#### Note:

- Microsoft® Windows® Internet Explorer® 8 and earlier versions are not supported.
- Android 4.1 or later versions are recommended.
- You can also access the User's Guide at the web page listed below.



[www.panasonic.net/pcc/support/tel/homenetwork/manual/](http://www.panasonic.net/pcc/support/tel/homenetwork/manual/)

# Specifications

- **Standards**  
DECT (Digital Enhanced Cordless Telecommunications)
- **Frequency range**  
DECT: 1.88 GHz – 1.90 GHz
- **RF transmission power**  
DECT: Approx. 10 mW (average power per channel)
- **Power source**  
220 – 240 V AC, 50/60 Hz
- **Power consumption**  
Standby: Approx. 2.0 W  
Maximum: Approx. 3.0 W
- **Alert tone volume**  
Approx. 110 dB (High alert level)  
(measured approx. 10 cm from the product)
- **Operating conditions**  
0 °C – 40 °C
- **Dimensions (height × width × depth)**  
Approx. 71 mm × 73 mm × 46 mm
- **Mass (weight)**  
Approx. 90 g

---

## Warranty (for New Zealand)

### **Panasonic New Zealand undertakes to:**

Repair or at its option, replace without cost to the owner, either for material or labour, any part which is found to be defective within two years of the date of purchase.

### **THIS EXPRESS WARRANTY DOES NOT COVER:**

- 1) Pick up and delivery.
- 2) Batteries.
- 3) Repairs when the product has not been used in accordance with the Operating Instructions Manual or has been modified.
- 4) Normal maintenance and cleaning as required in the product's Operating Instructions Manual.
- 5) Service calls to:
  - a Correct the set up of the product
  - b Instruct you how to use the product
  - c Replace fuses or correct your building's wiring
- 6) Damage to the product caused by accident, misuse or Act of God.
- 7) Repairs when the product has been dismantled, repaired, modified or serviced by other than a Panasonic Authorised Dealer authorised to service that type of product.

### **IF YOUR PANASONIC PRODUCT FAILS WITHIN THE WARRANTY PERIOD:**

Take it to the Authorised Panasonic Dealer from whom you purchased the product who will repair it (or arrange to have it repaired) during their normal business hours. All enquiries regarding warranty or otherwise, please call – Customer Support Centre Tel. No.: (09) 272 0178

**NOTE: THIS EXPRESS WARRANTY IS OFFERED AS AN EXTRA BENEFIT AND DOES NOT AFFECT YOUR LEGAL RIGHTS.**

**For your future reference**

We recommend keeping a record of the following information to assist with any repair under warranty.

Serial No.	Date of purchase
(found inside the unit)	
Name and address of dealer	

Attach your purchase receipt here.
------------------------------------

<b>For Australia</b> <b>Customer Care Centre Tel. No.: 132600</b> <b>or website <a href="http://www.panasonic.com/au">www.panasonic.com/au</a></b> <b>For New Zealand</b> <b>Customer Care Centre Tel. No.: (09) 272 0178</b> <b>or website <a href="http://www.panasonic.com/nz">www.panasonic.com/nz</a></b>
---

**Sales Department:**

Panasonic Australia Pty. Limited

1 Innovation Road, Macquarie Park NSW 2113, Australia

**Sales Department:**

Panasonic New Zealand Ltd.

18 Sir Woolf Fisher Drive, Highbrook, East Tamaki, Auckland,  
New Zealand

Phone: (09) 272 0100

Fax: (09) 272 0137

Panasonic System Networks Co., Ltd.

1-62, 4-chome, Minoshima, Hakata-ku, Fukuoka 812-8531, Japan

© Panasonic System Networks Co., Ltd. 2015



\*PNQX7359ZA\*

**PNQX7359ZA** CC0715WK0 (E)