

2-WAY Mini-FSV LE2 Series

HP	4			4			5			5			6			6					
Model name	U-4LE2H4			U-4LE2H7			U-5LE2H4			U-5LE2H7			U-6LE2H4			U-6LE2H7					
Power supply	220/230/240V/ 1-phase/50Hz 220/230V/1-phase/60Hz			380/400/415V/ 3-phase/50Hz 380/400V/3-phase/60Hz			220/230/240V/ 1-phase/50Hz 220/230V/1-phase/60Hz			380/400/415V/ 3-phase/50Hz 380/400V/3-phase/60Hz			220/230/240V/ 1-phase/50Hz 220/230V/1-phase/60Hz			380/400/415V/ 3-phase/50Hz 380/400V/3-phase/60Hz					
Voltage	220V	230V	240V	380V	400V	415V	220V	230V	240V	380V	400V	415V	220V	230V	240V	380V	400V	415V			
Capacity	Cooling	kW	12.1			12.1			14.0			14.0			15.5			15.5			
		BTU/h	41,300			41,300			47,800			47,800			52,900			52,900			
Capacity	Heating	kW	12.5			12.5			16.0			16.0			16.5			16.5			
		BTU/h	42,700			42,700			54,600			54,600			56,300			56,300			
EER/COP	Cooling	W/W	5.08			5.08			4.61			4.61			4.27			4.27			
		W/W	5.95			5.95			5.25			5.25			5.08			5.08			
Dimensions	H x W x D	mm	996 x 980 x 370			996 x 980 x 370			996 x 980 x 370			996 x 980 x 370			996 x 980 x 370			996 x 980 x 370			
Net weight	kg	106			106			106			106			106			106				
Electrical ratings	Cooling	Running current	A	11.90	11.40	10.90	3.89	3.69	3.56	15.20	14.50	13.90	4.91	4.67	4.50	18.10	17.30	16.60	5.87	5.57	5.37
		Power input	kW	2.38	2.38	2.38	2.38	2.38	3.04	3.04	3.04	3.04	3.04	3.63	3.63	3.63	3.63	3.63	3.63	3.63	3.63
	Heating	Running current	A	10.60	10.10	9.70	3.47	3.29	3.18	15.20	14.60	14.0	4.93	4.68	4.51	16.20	15.50	14.90	5.25	4.99	4.81
		Power input	kW	2.10	2.10	2.10	2.10	2.10	3.05	3.05	3.05	3.05	3.05	3.05	3.05	3.25	3.25	3.25	3.25	3.25	3.25
Starting current	A	1			1			1			1			1			1				
Air flow rate	m ³ / min	69			69			72			72			74			74				
	L/s	1,150			1,150			1,200			1,200			1,233			1,233				
Refrigerant amount at shipment	kg	R410A 6.70			R410A 6.70			R410A 6.70			R410A 6.70			R410A 6.70			R410A 6.70				
Piping connection	Gas pipe	mm (inches)	Ø15.88 (Ø5/8)			Ø15.88 (Ø5/8)			Ø15.88 (Ø5/8)			Ø15.88 (Ø5/8)			Ø15.88 (Ø5/8)			Ø15.88 (Ø5/8)			
	Liquid pipe	mm (inches)	Ø9.52 (Ø3/8)			Ø9.52 (Ø3/8)			Ø9.52 (Ø3/8)			Ø9.52 (Ø3/8)			Ø9.52 (Ø3/8)			Ø9.52 (Ø3/8)			
Ambient temperature operating range	Cooling	-10°CDB~+46°CDB, Heating: -20°CWB~+18°CWB	-10°CDB~+46°CDB, Heating: -20°CWB~+18°CWB			-10°CDB~+46°CDB, Heating: -20°CWB~+18°CWB			-10°CDB~+46°CDB, Heating: -20°CWB~+18°CWB			-10°CDB~+46°CDB, Heating: -20°CWB~+18°CWB			-10°CDB~+46°CDB, Heating: -20°CWB~+18°CWB			-10°CDB~+46°CDB, Heating: -20°CWB~+18°CWB			
	Normal mode	dB(A)	52.0			52.0			53.0			53.0			54.0			54.0			
Sound pressure level (Cooling)	Silent mode (3)	dB(A)	45.0			45.0			46.0			46.0			47.0			47.0			
Sound power level (Cooling)	Normal mode	dB	69.0			69.0			71.0			71.0			73.0			73.0			
Global remarks	Rated conditions:	Cooling	27°C DB / 19°C WB			27°C DB / 19°C WB			27°C DB / 19°C WB			27°C DB / 19°C WB			27°C DB / 19°C WB			27°C DB / 19°C WB			
	Indoor air temperature	Heating	20°C DB			20°C DB			20°C DB			20°C DB			20°C DB			20°C DB			
	Outdoor air temperature		35°C DB			35°C DB			35°C DB			35°C DB			35°C DB			35°C DB			

These specifications are subject to change without notice. High durable model (with suffix "E") has same specifications.

Dimensions

U-4LE2H4 / U-4LE2H7
U-5LE2H4 / U-5LE2H7
U-6LE2H4 / U-6LE2H7

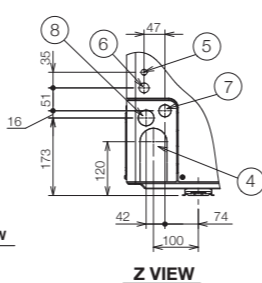
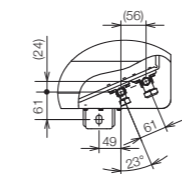
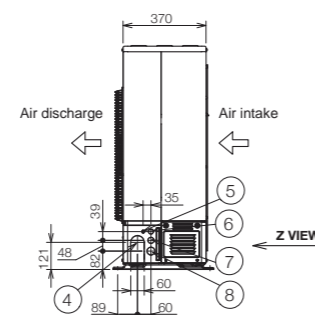
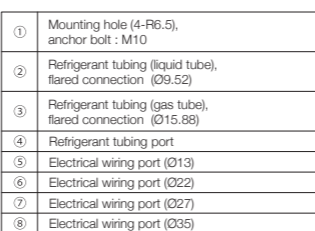
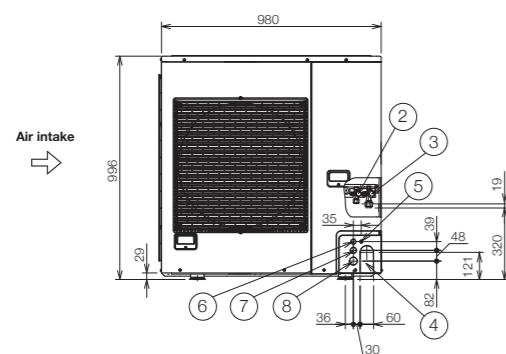
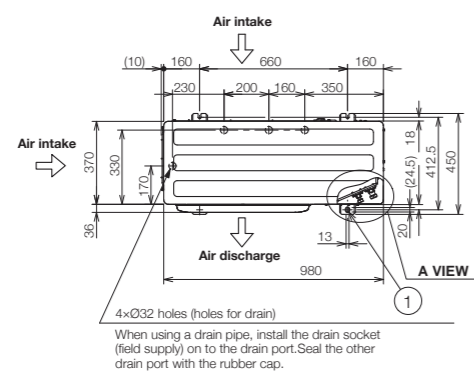

Unit: mm

2-WAY Mini-FSV LE1/LEY Series

HP	8			8			10			10					
Model name	U-8LE1H7			U-8LEY1V9			U-10LE1H7			U-10LEY1V9					
Power supply	380/400/415V/3-phase/50Hz 380/400V/3-phase/60Hz			220V/3-phase/60Hz			380/400/415V/3-phase/50Hz 380/400V/3-phase/60Hz			220V/3-phase/60Hz					
Voltage	380V	400V	415V	220V			380V	400V	415V	220V					
Capacity	Cooling	kW	22.4			20.0			28.0			28.0			
		BTU/h	76,500			68,300			95,600			95,600			
Capacity	Heating	kW	25.0			22.5			28.0			31.5			
		BTU/h	85,300			76,800			95,600			107,500			
EER/COP	Cooling	W/W	4.20			3.88			3.59			2.89			
		W/W	4.52			3.09			4.55			2.33			
Dimensions (H/W/D)	mm	1,500 x 980 x 370			1,500 x 980 x 370			1,500 x 980 x 370			1,500 x 980 x 370				
Net weight	kg	132			132			133			133				
Electrical ratings	Cooling	Running current	A	8.70	8.25	7.95	20.0			12.7	12.1	11.7	37.0		
		Power input	kW	5.33	5.33	5.33	5.16			7.8	7.80	7.80	9.68		
	Heating	Running current	A	9.05	8.60	8.25	27.0			10.0	9.55	9.20	40.0		
		Power input	kW	5.53	5.53	5.53	7.29			6.15	6.15	6.15	6.15		
Starting current	A	1			20			1			37				
Air flow rate	m ³ / min	150			150			160			160				
	L/s	2,500			2,500			2,666			2,666				
Refrigerant amount at shipment	kg	R410A 6.30			R410A 6.30			R410A 6.60			R410A 6.60				
Piping connection	Gas pipe	mm (inches)	Ø19.05 (Ø3/4)			Ø19.05 (Ø3/4)			Ø22.22 (Ø7/8)			Ø22.22 (Ø7/8)			
	Liquid pipe	mm (inches)	Ø9.52 (Ø3/8)			Ø9.52 (Ø3/8)			Ø9.52 (Ø3/8)			Ø9.52 (Ø3/8)			
Ambient temperature operating range	Cooling	-10°CDB~+46°CDB, Heating: -20°CWB~+18°CWB	-10°CDB~+46°CDB, Heating: -20°CWB~+18°CWB			-10°CDB~+43°CDB, Heating: -20°CWB~+18°CWB			-10°CDB~+46°CDB, Heating: -20°CWB~+18°CWB			-10°CDB~+43°CDB, Heating: -20°CWB~+18°CWB			
	Normal mode	dB(A)	59.0			59.0			62.0			62.0			
Sound pressure level (Cooling)	Silent mode (3)	dB(A)	52.0			52.0			55.0			52.0			
Sound power level (Cooling)	Normal mode	dB(A)	80.0			80.0			83.0			80.0			
Global remarks	Rated conditions:	Cooling	27°C DB / 19°C WB			27°C DB / 19°C WB			27°C DB / 19°C WB			27°C DB / 19°C WB			
	Indoor air temperature	Heating	20°C DB			20°C DB			20°C DB			20°C DB			
	Outdoor air temperature		35°C DB			35°C DB			35°C DB			35°C DB			

These specifications are subject to change without notice. High durable model (with suffix "E") has same specifications.

Dimensions

U-8LE1H7 / U-10LE1H7 / U-8LEY1V9 / U-10LEY1V9

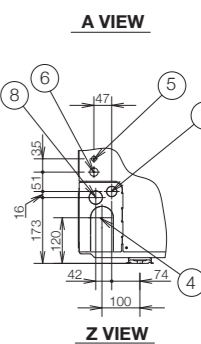
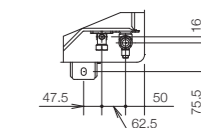
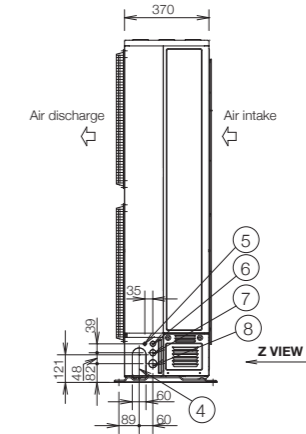
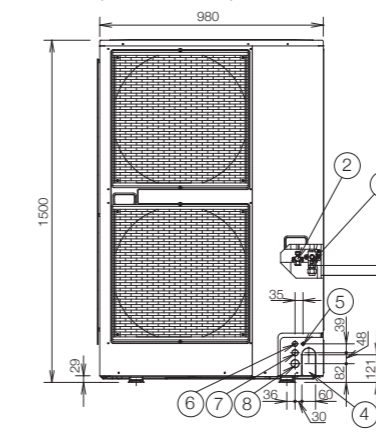
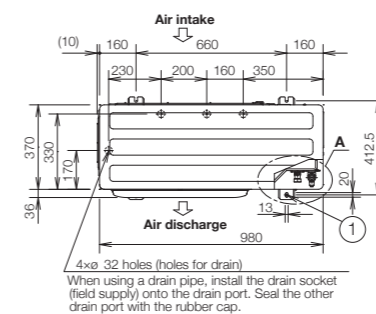

Unit: mm