

## 2-WAY Mini-FSV LE1/LEY Series

HP	8			8	10			10			
Model name	U-8LE1H7			U-8LEY1V9	U-10LE1H7			U-10LEY1V9			
Power supply	380/400/415V/3-phase/50Hz 380/400V/3-phase/60Hz			220V/3-phase/60Hz	380/400/415V/3-phase/50Hz 380/400V/3-phase/60Hz			220V/3-phase/60Hz			
Voltage	380V	400V	415V	220V	380V	400V	415V	220V			
Capacity	Cooling	kW	22.4			20.0	28.0			28.0	
		BTU/h	76,500			68,300	95,600			95,600	
	Heating	kW	25.0			22.5	28.0			31.5	
		BTU/h	85,300			76,800	95,600			107,500	
EER/COP	Cooling	W/W	4.20			3.88	3.59			2.89	
	Heating	W/W	4.52			3.09	4.55			2.33	
Dimensions (H/W/D)	mm			1,500 x 980 x 370	1,500 x 980 x 370	1,500 x 980 x 370			1,500 x 980 x 370		
Net weight	kg			132	132	133			133		
Electrical ratings	Cooling	Running current	A	8.70	8.25	7.95	20.0	12.7	12.1	11.7	37.0
		Power input	kW	5.33	5.33	5.33	5.16	7.8	7.80	7.80	9.68
	Heating	Running current	A	9.05	8.60	8.25	27.0	10.0	9.55	9.20	40.0
		Power input	kW	5.53	5.53	5.53	7.29	6.15	6.15	6.15	6.15
Starting current	A			1	20	1			37		
Air flow rate	m <sup>3</sup> / min			150	150	160			160		
	L/s			2,500	2,500	2,666			2,666		
Refrigerant amount at shipment	kg			R410A 6.30	R410A 6.30	R410A 6.60			R410A 6.60		
Piping connection	Gas pipe	mm (inches)			Ø19.05 (Ø3/4)	Ø19.05 (Ø3/4)	Ø22.22 (Ø7/8)			Ø22.22 (Ø7/8)	
	Liquid pipe	mm (inches)			Ø9.52 (Ø3/8)	Ø9.52 (Ø3/8)	Ø9.52 (Ø3/8)			Ø9.52 (Ø3/8)	
Ambient temperature operating range		Cooling: -10°CDB~+46°CDB, Heating: -20°CWB~+18°CWB			Cooling: -10°CDB~+43°CDB, Heating: -20°CWB~+18°CWB	Cooling: -10°CDB~+46°CDB, Heating: -20°CWB~+18°CWB			Cooling: -10°CDB~+43°CDB, Heating: -20°CWB~+18°CWB		
Sound pressure level (Cooling)	Normal mode	dB(A)			59.0	59.0	62.0			62.0	
	Silent mode (3)	dB(A)			52.0	52.0	55.0			52.0	
Sound power level (Cooling)	Normal mode			dB(A)			80.0	83.0			80.0

Global remarks	Rated conditions:	
	Cooling	Heating
	Indoor air temperature	27°C DB / 19°C WB
Outdoor air temperature	35°C DB	7°C DB / 6°C WB

These specifications are subject to change without notice.  
High durable model (with suffix "E") has same specifications.

### Dimensions

#### U-8LE1H7 / U-10LE1H7 / U-8LEY1V9 / U-10LEY1V9

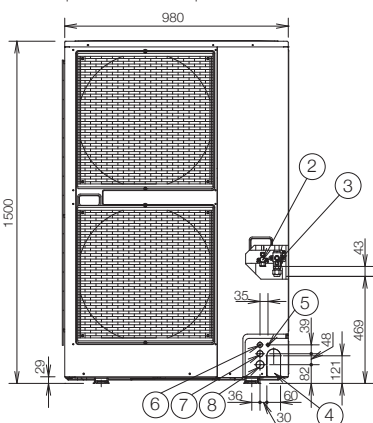
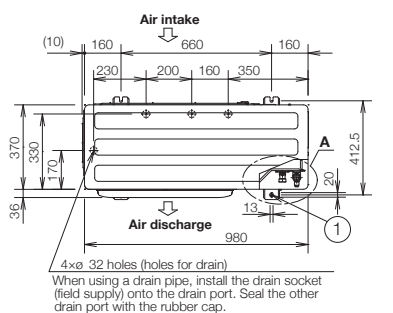

- ① Mounting hole (4-R6.5), anchor bolt : M10
- ② Refrigerant tubing (liquid tube), flared connection (ø9.52) for 8-10 HP finally.
- ③ Refrigerant tubing (gas tube), flared connection (ø19.05)
- ④ Refrigerant tubing port
- ⑤ Electrical wiring port (ø13)
- ⑥ Electrical wiring port (ø22)
- ⑦ Electrical wiring port (ø27)
- ⑧ Electrical wiring port (ø35)

**For U-10LEY1H7**  
The tubing of the gas main has a diameter of ø22.22, but the connection to the service valve of the outdoor unit has a diameter of ø19.05, so a flare has to be used. Consequently, be sure to use the enclosed joint tube B and joint tube A in making connections (brazing).

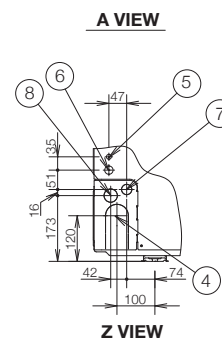
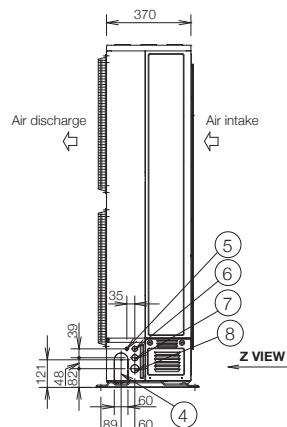
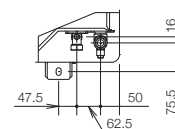

Unit: mm