

Maintenance Space

Wiring Diagram

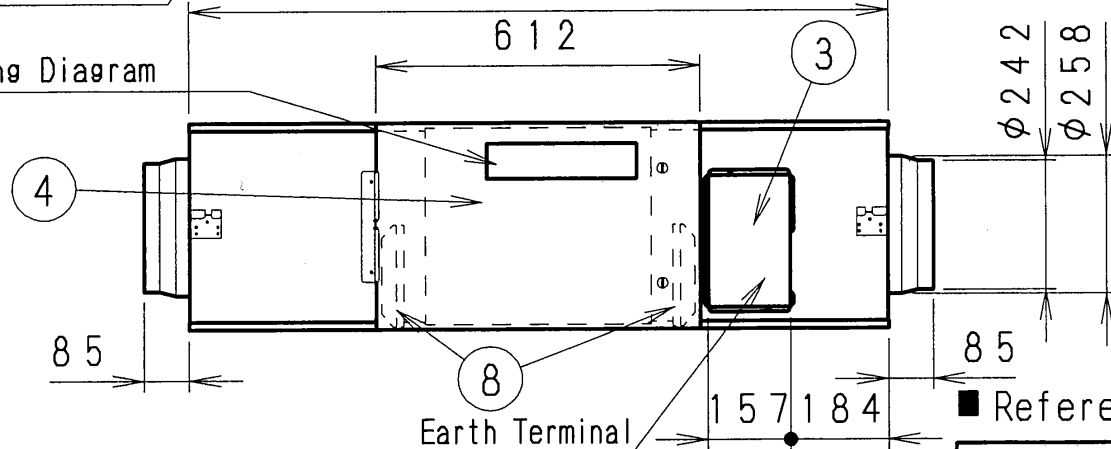

Inspection Opening  $\square 450$

(For the inspection of the filters, heat exchange elements, fans, motors, and damper)

An inspection opening is necessary to clean the heat exchange element and filter once or twice a year.



\*Please don't use in any direction other than the above.

■ Reference Sketch

NO.	Parts Name	Qty.	Material	Remarks
1	Frame	1	Galvanized sheets	
2	Adapter	4	ABS	
3	Electrical Equipment Box	1		
4	Inspection Cover	1	Galvanized sheets	
5	Fan	2	ABS	
6	Motor	2		
7	Heat Exchange Element	4	Special paper + Resin	
8	Filter	2	Nylon-Polyester Fiber	Collection Efficiency AFI 82%
9	Damper	1		
10	Damper Motor	1		
11	Ceiling Suspension Fixture	4	Galvanized sheets	

■ Be careful of dewing and frosting.

As shown in the Figure, suppose a high temp absorbing air condition A and a low temp absorbing air condition B are plotted on the air line figure, then a high temp air A is heat-exchanged by the unit and goes out of the saturation curve as shown by Point C. In this case, the unit will be dewed or frosted. To avoid this, you are required to heat a low temp air B up to B' so as to get C' below the saturation curve, before using the unit.

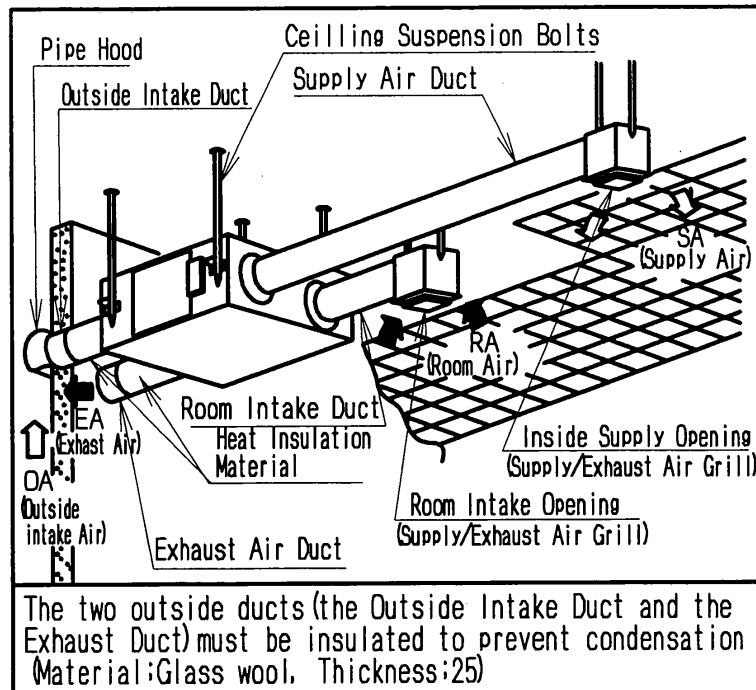
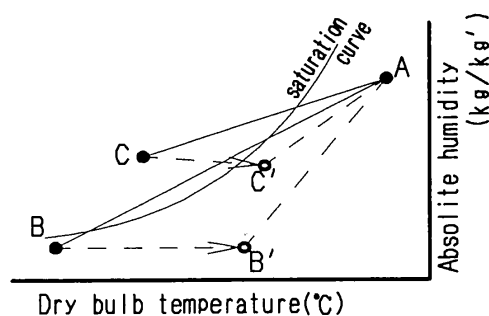

The two outside ducts (the Outside Intake Duct and the Exhaust Duct) must be insulated to prevent condensation. Material: Glass wool, Thickness: 25

\* Duct size (Nominal Diameter):  $\phi 250$

\*\* The above dimensions do not include the thickness of the insulation material on the unit body.

Name				Model No.	
Energy Recovery Ventilator (Dimensions)				FY-01KZDY8A	
Date of Made	2012.12.20	Scale	Drawing	Rev. NO.	
Date of Revision		Free	Reference No.	0	
Panasonic Ecology Systems Guang Dong Co., Ltd., Beijing Branch					

■ Specifications

Model No.	Power Source	Notch	Frequency (Hz)	Heat Exchange Ventilation								Normal Ventilation				Product Weight (kg)	
				Input (W)	Current (A)	Volume (m <sup>3</sup> /h)	External Static Pressure (Pa)	Temperature Exchange Efficiency (%)	Enthalpy Exchange Efficiency (%)		Noise (dB)	Input (W)	Current (A)	Air Volume (m <sup>3</sup> /h)	External Static Pressure (Pa)		Noise (dB)
									Cooling	Heating							
01KZDY8A	220-240V a.c.	Extra High	50	437-464	1.99-1.93	1000	105	75	65	71	37.5-38.5	437-464	1.99-1.93	1000	105	39.5-40.5	83
		High	50	416-432	1.89-1.80	1000	80	75	65	71	37.0-37.5	416-432	1.89-1.80	1000	80	39.0-39.5	
		Low	50	301-311	1.37-1.29	700	75	79	70	76	33.5-34.5	301-311	1.37-1.29	700	75	35.5-36.5	

\* This noise of the product is the value which was measured at the acoustic room. Actually, in the established condition, that undergo influence by the echoing of the room and so that become bigger than the display numerical value.

■ Performance  
P-Q Curve

Efficiency Curve — 220V-240V~50Hz

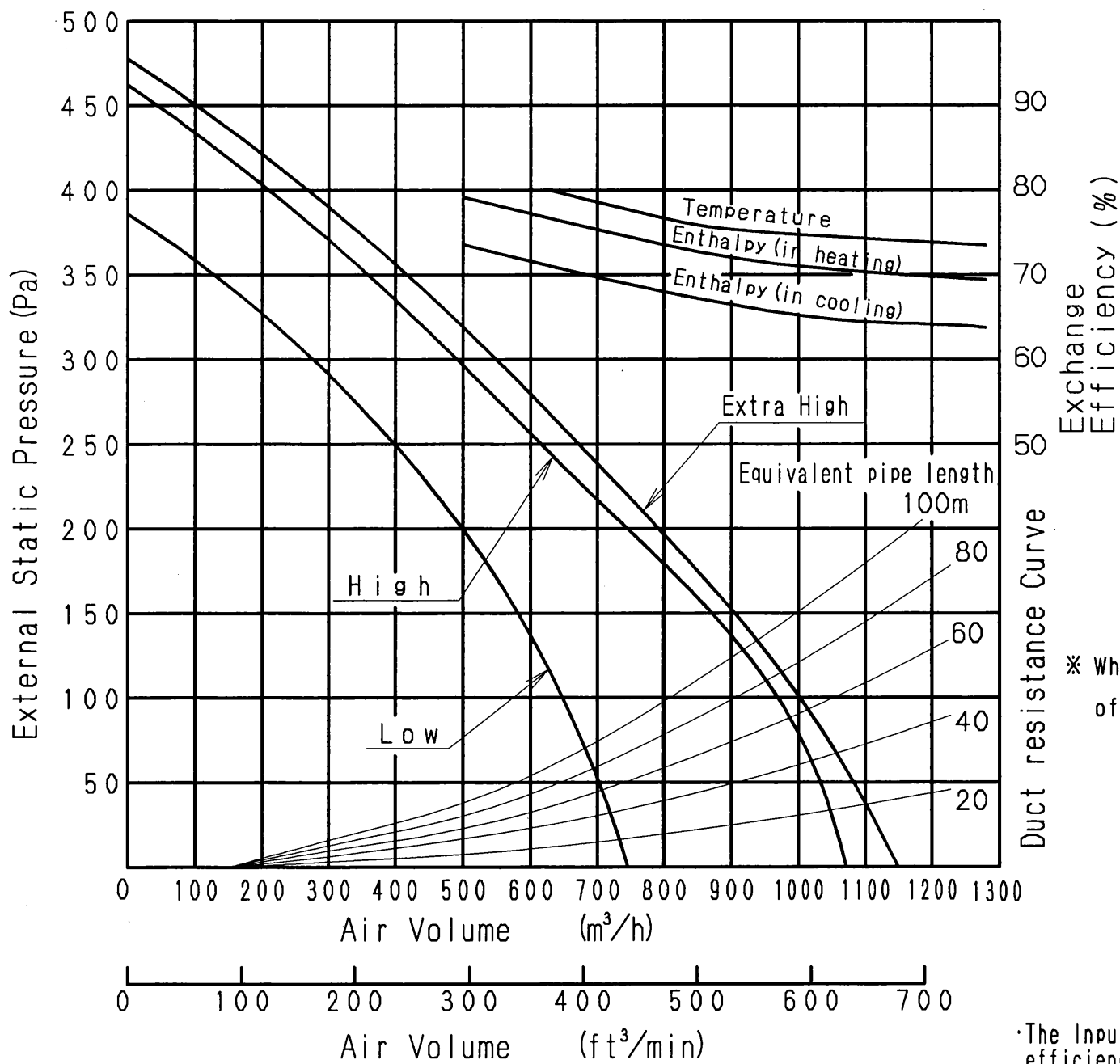

The Input, the current and the exchange efficiency are values at the time of the mentioned air volume.

The noise level shall be measured 1.5m below the center of the unit.

The temperature exchange efficiency averages that of when cooling and when heating.

Use conditions

Outdoor air conditions  
Temperature range -10°C~40°C  
Relative humidity 85% or less

Indoor air conditions  
Temperature range -10°C~40°C  
Relative humidity 85% or less

Installation requirements  
Same as the indoor air conditions

\*Indoor air here means air in air-conditioned living rooms. Its use in refrigerators or other places where temperature can fluctuate greatly is prohibited even if a temperature range is acceptable.

**Example** Indoor air conditions  
During cooling period  
Temperature 27°C  
Relative humidity 50%

During heating period  
Temperature 20°C  
Relative humidity 40%

■ Motor Specifications

Type	4 Poles open type induction motor
Rating	Cont.
Insulation Class	class E
Temperature Rise	under 75 K
Surrounding Temperature	-10°C~40°C
Insulation Resistance	over 1M $\Omega$ (by DC500V)
Withstand Voltage	AC 1,500V for 1min

Name		Model No.	
Energy Recovery Ventilator (Specifications)		FY-01KZDY8A	
Date of Made	2012.12.20	Scale	Drawing
Date of Revision		Free Reference No.	1
Panasonic Ecology Systems Guang Dong Co.,Ltd.,Beijing Branch			