

■ Maintenance Dimension

It must be set the maintenance cover, and clean the filter and heat exchange core as specified in instruction.

UNIT: mm

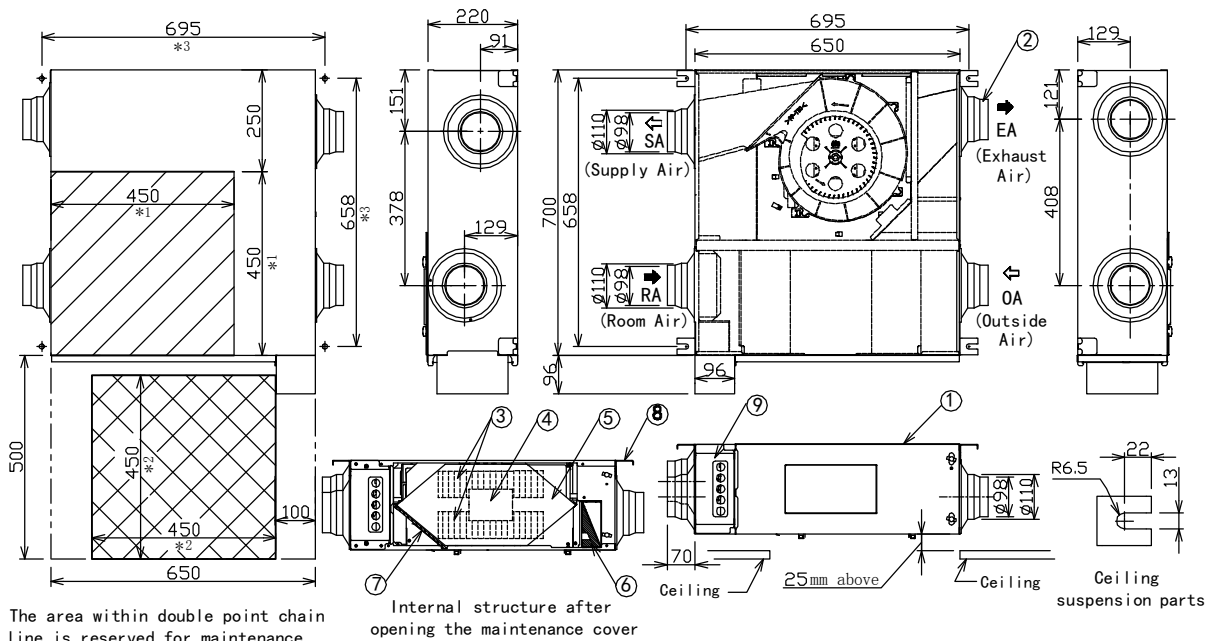

- *1. Dimension of filter maintenance cover.
- *2. Dimension of maintenance cover.
- *3. Suspension point dimension

NO.	Part name	Q'ty	Material	Remarks
1	Frame	1	Galvanized steel sheet	
2	Adapter	4	ABS	
3	Impeller	2	PP	
4	Fan motor	1		
5	Heat exchange core	1	Special paper+resin	
6	Outdoor filter	1	Nonwoven Fabric	
7	Indoor filter	1		
8	Ceiling suspension	4	Galvanized steel sheet	
9	Switch box	1	Galvanized steel sheet	

■ Installation diagram

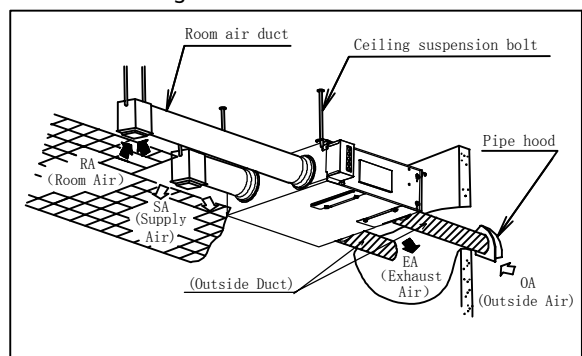

1. Duct size (Nominal Diameter): $\varnothing 100$.
2. The above dimensions do not include the thickness of the insulation material in the unit.

■ Be careful of dew and frost

1. The two outside ducts must be insulated to prevent condensation. (Material :Glass wool.Thickness:25mm)
2. Outside air may come into the room in cold area and place where outside air speed is high .
3. In order to prevent the water from ingessing, install the two outside ducts inclined to outside .
4. As shown in the Figure,suppose a high temperature absorbing air condition A and a low temperature absorbing air condition B are plotted on the air line figure ,then a high temperature air A is heat-exchanged by the unit and gose out of the saturation curve as shown by point C .In this case ,the unit will be dewed or frosted. To aboid this,you are required to heat a low temperature air B up to B' so as to get C' below the saturation curve ,before using the unit.

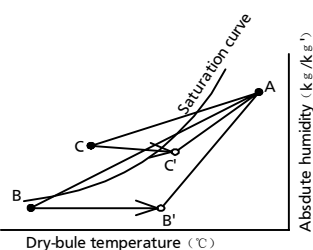

Name		Model No.	
Energy Recovery Ventilator		FY-E15DZ1L	
Date of Made	2015.03.13	Scale	Drawing
Date of Revision		Free	Reference No.
Panasonic Ecology Systems Guangdong Co.,Ltd.,Beijing Branch		Consale Drawing	
		Rev.No.	

■ Specification

power Source	Notch	Heat Exchange Ventilation								Noise [dB(A)]	Product Weight [kg]
		Input [W]	Current [A]	Air Volume (m ³ /h)	External Static Pressure [Pa]	Temperature Exchange Efficiency [%]		Enthalpy Exchange Efficiency [%]			
						Cooling	Heating	Cooling	Heating		
220V ~ 50Hz	Extra High	85	0.39	150	100	63	78	66	73	28	27
	High	79	0.36	150	55	63	78	66	73	28	
	Low	45	0.20	100	0	68	80	72	75	22	

- The input power, the current and the exchange efficiency are measured at the standard air volume.
- The noise is measured 1.5m away from the underface of the unit.
The noise value measured at the total acoustic room is more than the indicated value in actual operation. because it's affected by enviroment.
- The above parameters are tested according to standard JIS B 8628.

■ Performance P-Q Curve

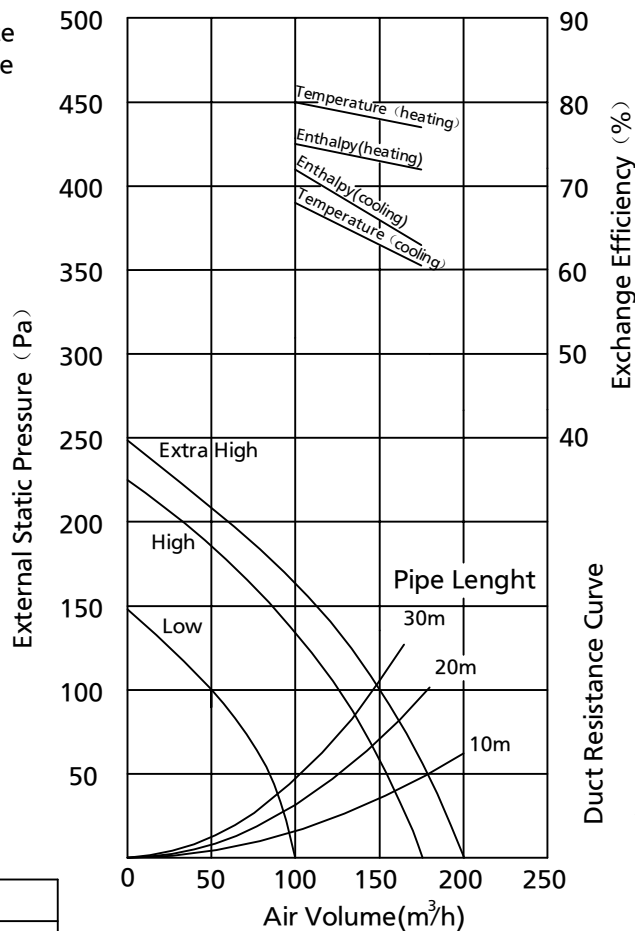

※When friction coefficient of pipe(duct) $\lambda = 0.02$

Use conditions

Outdoor air range
Temperature range -10℃ ~40℃。
Relative humidity 85% or less。
Indoor air range
Temperature range -10℃ ~40℃。
Relative humidity 85% or less。
Installation requirements
Same as the indoor air conditions
*Indoor air here means air in air-conditioned living rooms.
Its use in refrigerators or other places where temperature can fluctuate greatly is prohibited even if a temperature range is acceptable.
Example Indoor air conditions
During cooling period
Temperature 27℃
Relative humidity 50%
During heating period
Temperature 20℃
Relative humidity 40%

As shown in the Figure, suppose a high temperature absorbing air condition A and a low temperature absorbing air condition B are plotted on the air line figure, then a high temperature air A is heat-exchanged by the unit and goes out of the saturation curve as shown by point C. In this case, the unit will be dewed or frosted. To avoid this, you are required to heat a low temperature air B up to B' so as to get C' below the saturation curve, before using the unit.

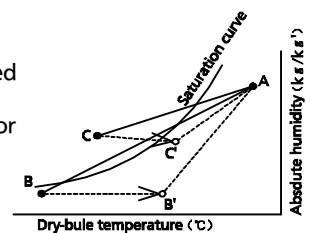

Name				Model No.	
Energy Recovery Ventilator				FY-E15DZ1L	
Date of Made	2015.03.13	Scale	Drawing Reference No.	Rev.No.	
Date of Revision		Free			
Panasonic Ecology Systems Guangdong Co.,Ltd.,Beijing Branch					