

## R1 TYPE CONCEALED FLOOR STANDING Dimensions

- 1 4 x Ø12 holes (for floor fixing)
- 2 Electric equipment box
- 3 Power supply outlet
- 4 Air filter
- 5 Discharge duct connection flange
- 6 Refrigerant connection outlet (liquid pipes)
- 7 Refrigerant connection outlet (gas pipes)
- 8 Drain filter
- 9 Drain pan
- 10 Level adjustment bolt
- 11 Drain outlet VP20 (with vinyl hose)

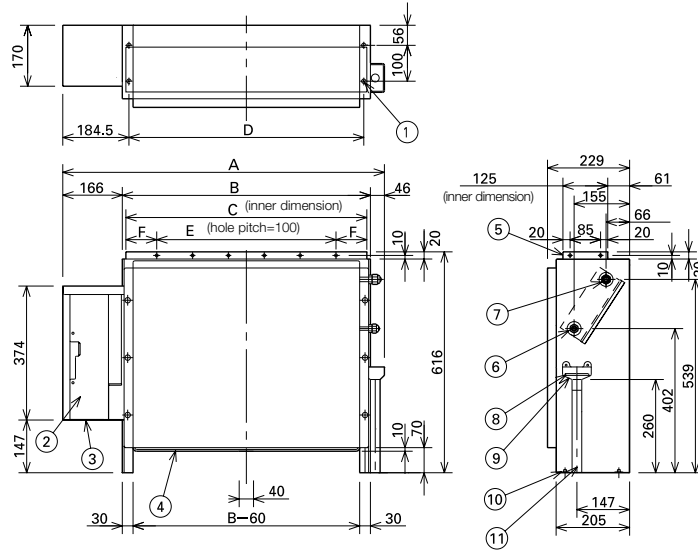

unit: mm

Indoor unit	A	B	C	D	E	F	Liquid pipes	Gas pipes
22 to 36 type	904	692	672	665	500	86	Ø6.35	Ø12.7
45 type	1,219	1,007	1,002	980	900	51		
56 type								
71 type							Ø9.52	Ø15.88