

Kích thước

1 Dàn lạnh

1.1 CS-N18ZKH-8 / CS-N24ZKH-8

<Mặt trên>

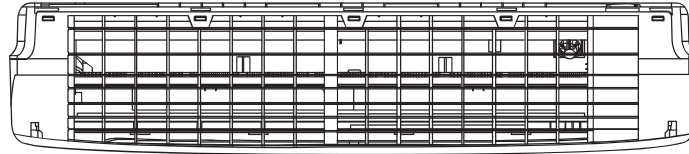

<Mặt bên>

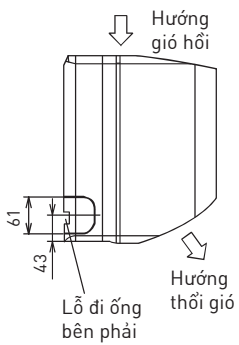

<Mặt trước>

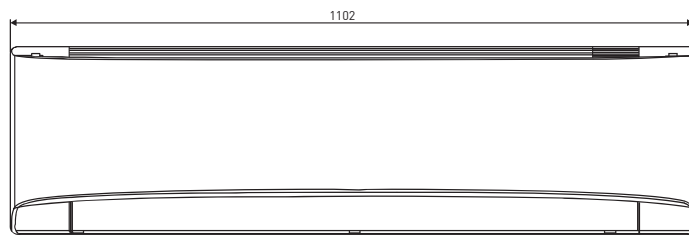

<Mặt bên>

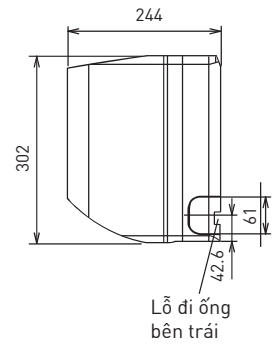

<Mặt dưới>

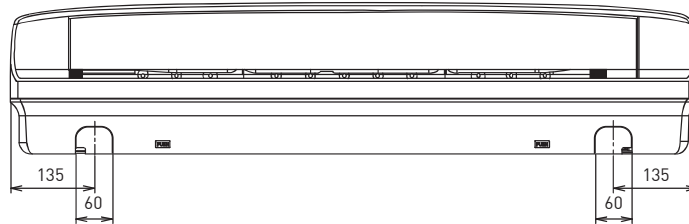

<Mặt sau>

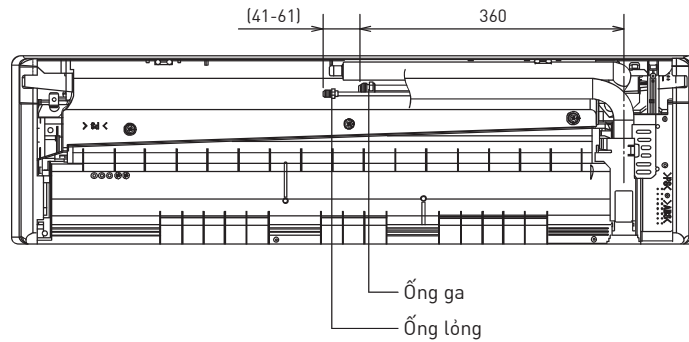

<Điều khiển từ xa>

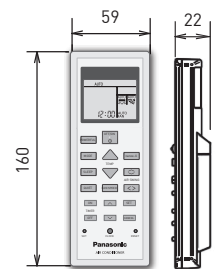

<Giá đỡ điều khiển từ xa>

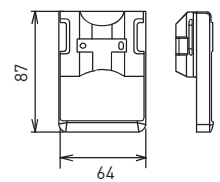

Vị trí tương đối giữa dàn lạnh và giá treo dàn lạnh <Mặt trước>

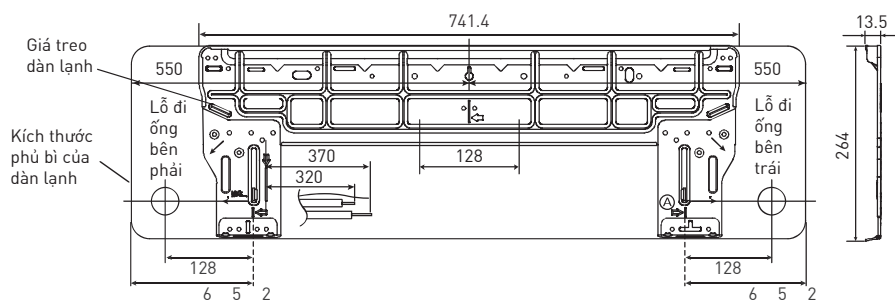

Đơn vị: mm

2 Dàn nóng

2.1 CU-N18ZKH-8 / CU-N24ZKH-8

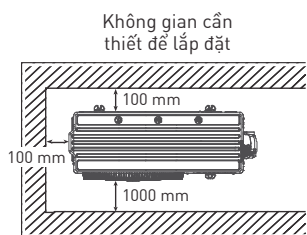

Vị trí tâm lỗ của giá đỡ dàn nóng
330 x 540

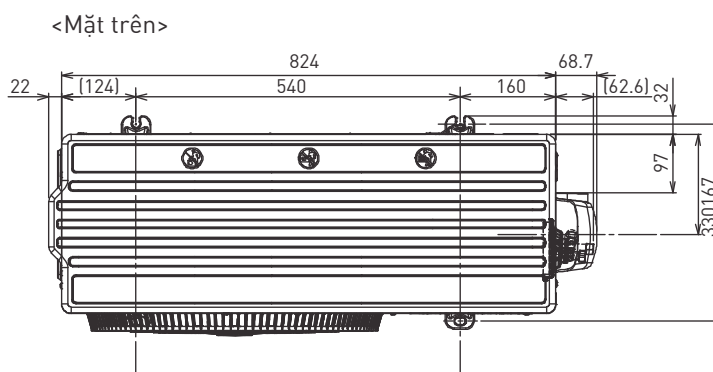

<Mặt bên>

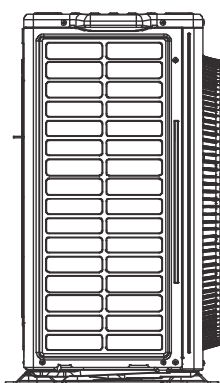

Đơn vị: mm

<Mặt trước>

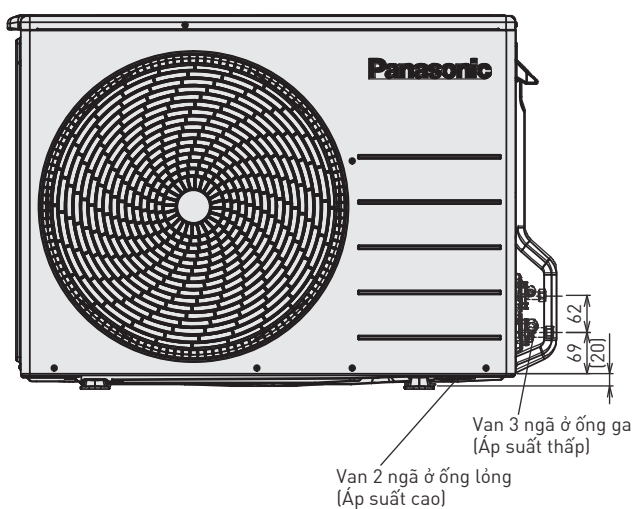

<Mặt bên>

