

FV12NS3

Panasonic Ecology Systems Guangdong Co., Ltd.

Specification Data Sheet

Issue date: 2009.05.22

Revise date: 2009.06.19

Cabinet Fan Model No. FV-12NS3

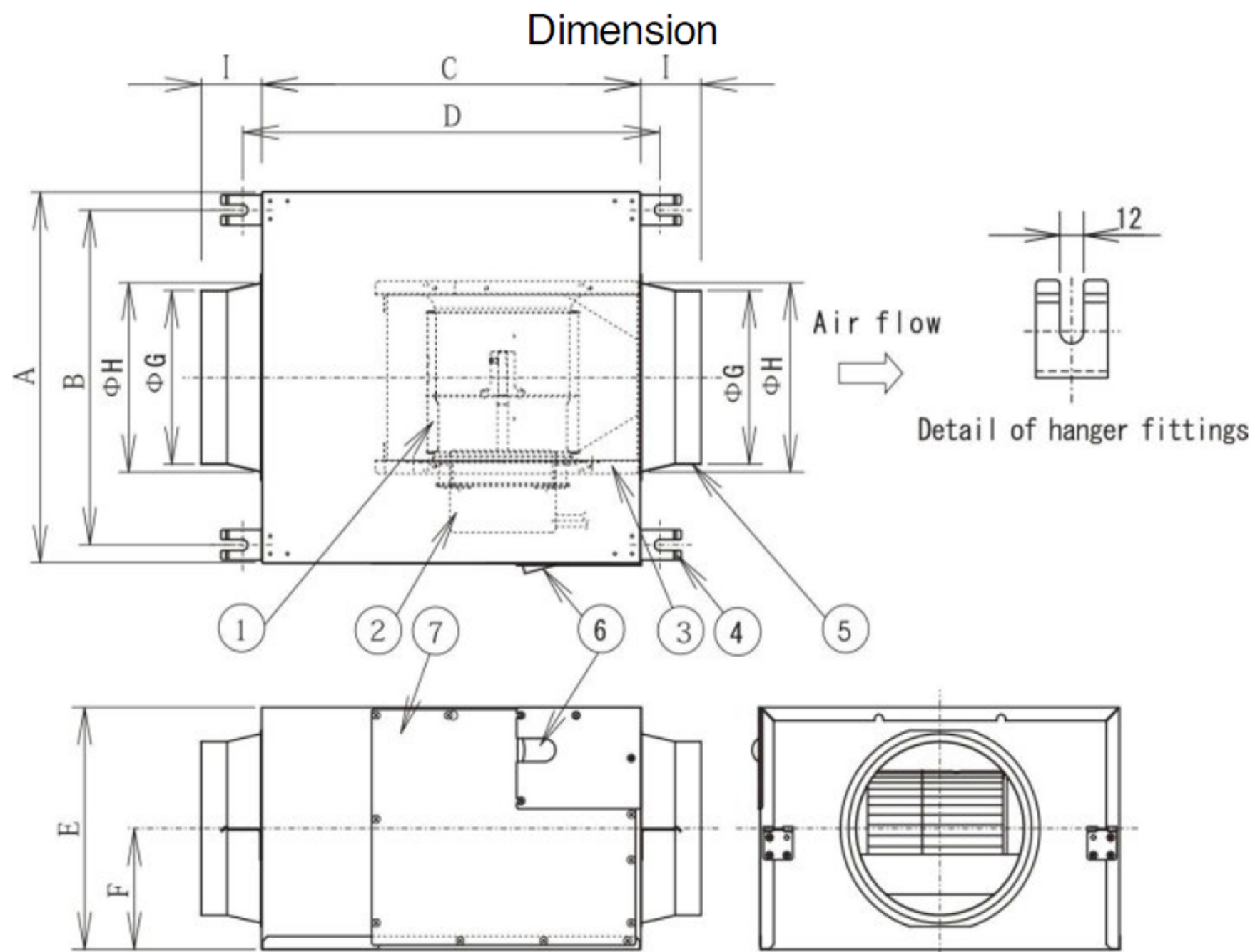

Parts list

No.	Parts name	Q'ty	Material
1	Impeller	1	METAL
2	Motor	1	-
3	Fan casing	1	METAL
4	Hanger fitting	4	METAL
5	Adapter	2	METAL
6	Terminal cover	1	METAL
7	Inspection panel	1	METAL

FV15NS3

Panasonic Ecology Systems Guangdong Co., Ltd.

Specification Data Sheet

Issue date: 2009.05.22

Revise date: 2009.06.19

Cabinet Fan Model No. FV-15NS3

Dimension

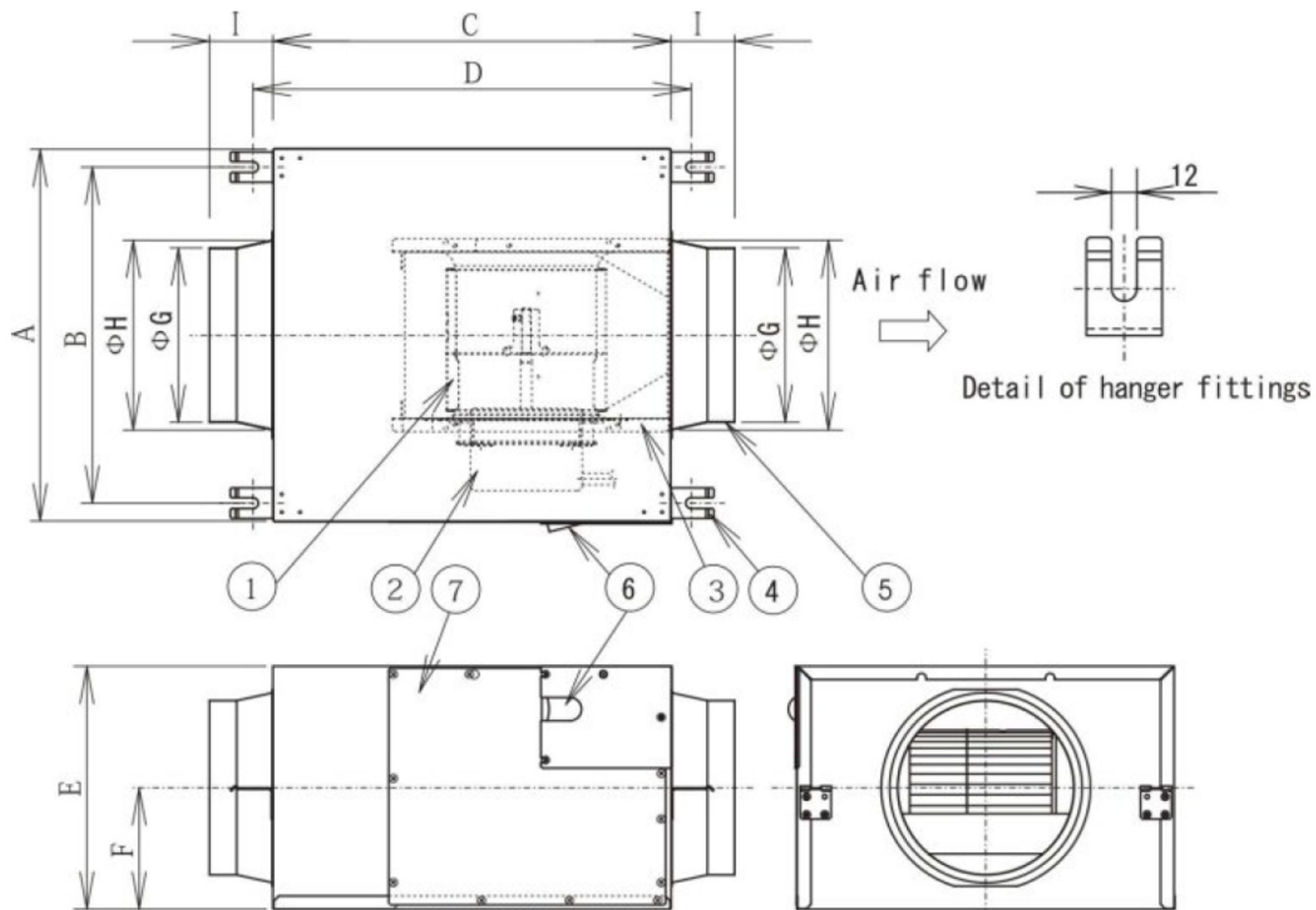

Parts list

No.	Parts name	Q'ty	Material
1	Impeller	1	METAL
2	Motor	1	-
3	Fan casing	1	METAL
4	Hanger fitting	4	METAL
5	Adapter	2	METAL
6	Terminal cover	1	METAL
7	Inspection panel	1	METAL

Unit: mm

A	B	C	D	E	F	G	H	I	CONNECTER DUCT DIMENSION
290	250	302	346	206	103	145	163	60	Φ 150

FV18NS3

Panasonic Ecology Systems Guangdong Co., Ltd.

Specification Data Sheet

Issue date: 2009.05.22

Revise date: 2009.06.19

Cabinet Fan Model No. FV-18NS3

Dimension

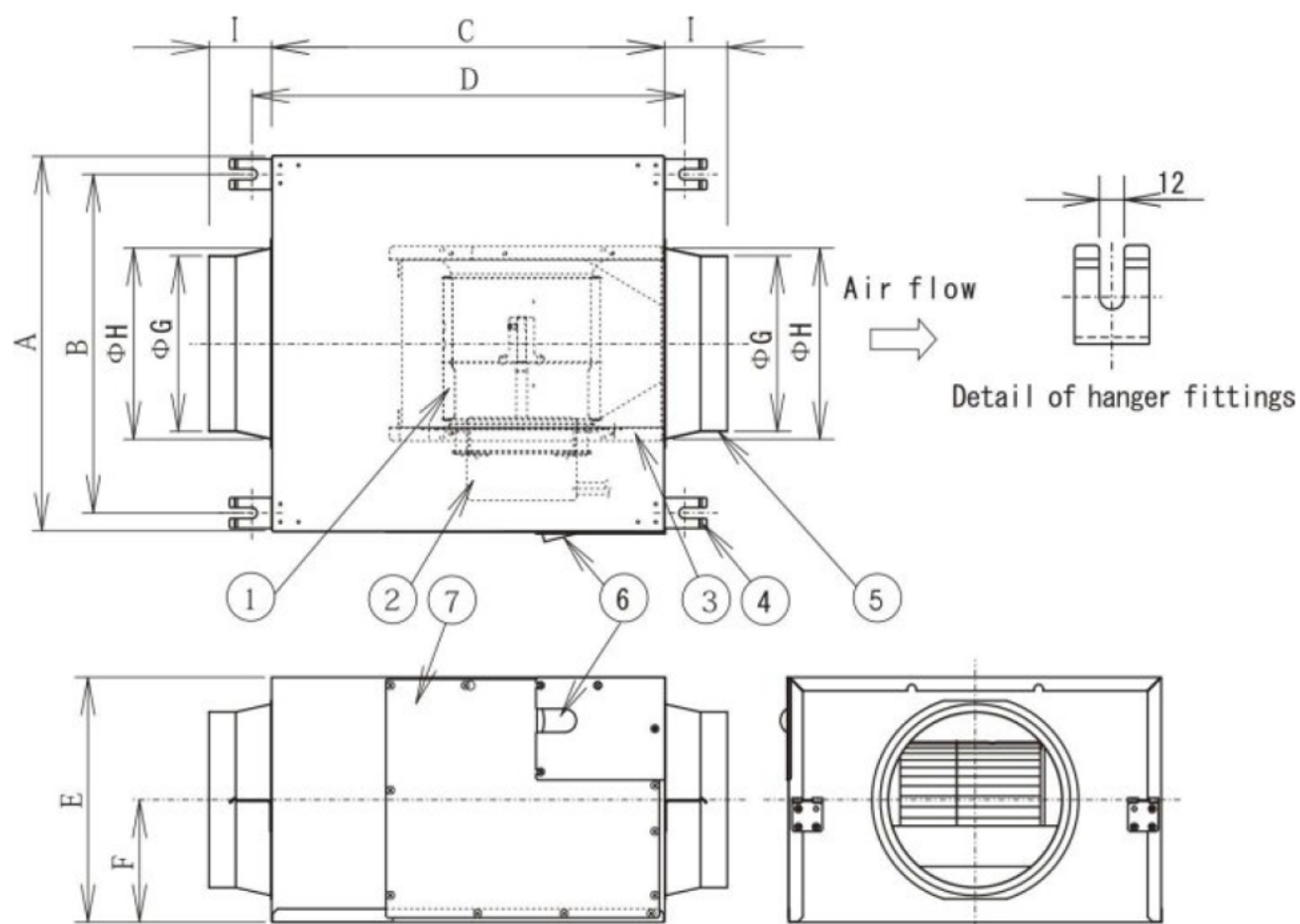

Parts list

No.	Parts name	Q'ty	Material
1	Impeller	1	METAL
2	Motor	1	-
3	Fan casing	1	METAL
4	Hanger fitting	4	METAL
5	Adapter	2	METAL
6	Terminal cover	1	METAL
7	Inspection panel	1	METAL

Unit: mm

A	B	C	D	E	F	G	H	I	CONNECTER DUCT DIMENSION
316	276	338	382	232	116	145	163	60	Φ150

FV20NS3

Panasonic Ecology Systems Guangdong Co., Ltd.

Specification Data Sheet

Issue date: 2009.05.22

Revise date: 2009.06.19

Cabinet Fan Model No. FV-20NS3

Dimension

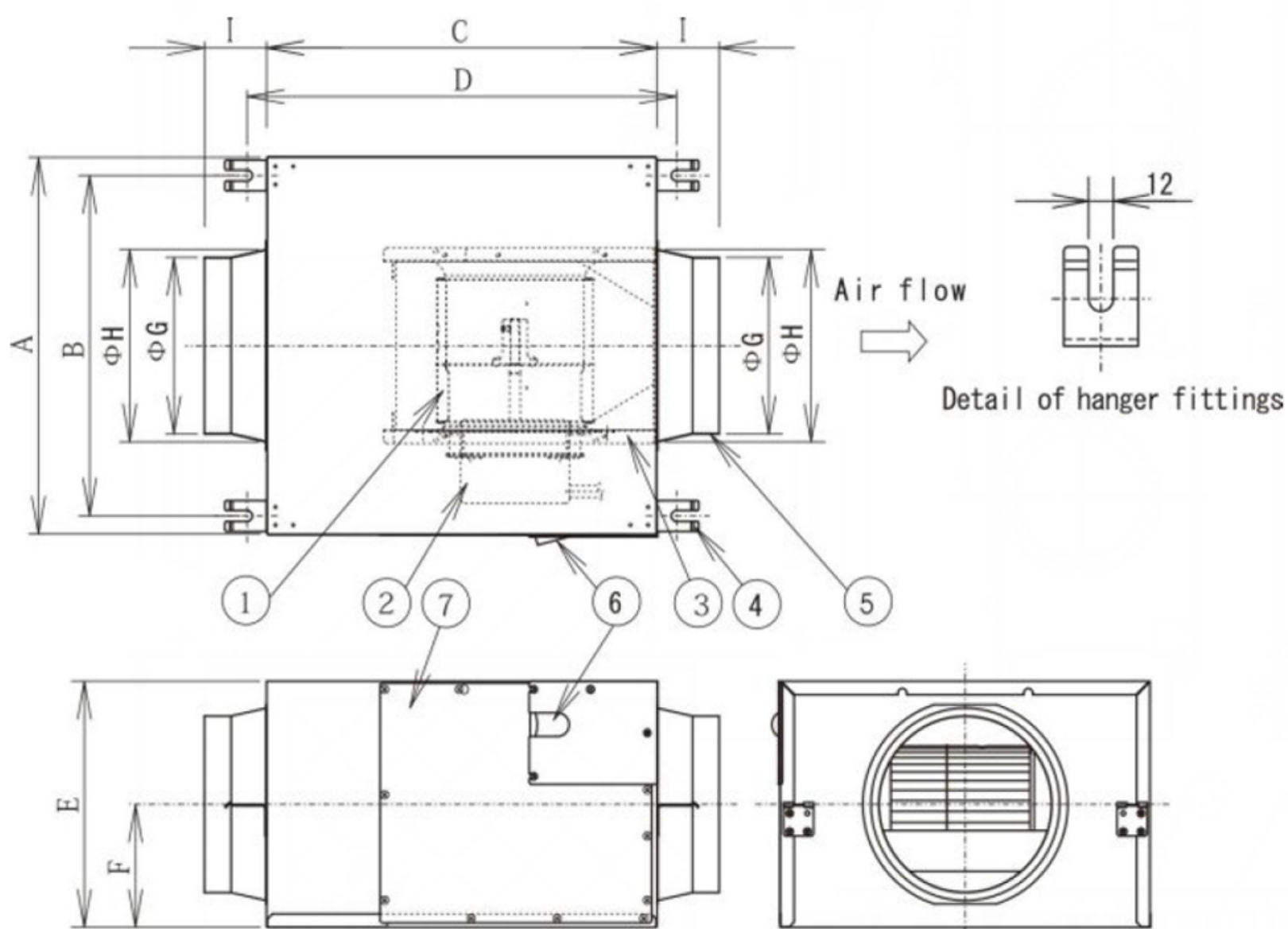

Parts list

No.	Parts name	Q'ty	Material
1	Impeller	1	METAL
2	Motor	1	-
3	Fan casing	1	METAL
4	Hanger fitting	4	METAL
5	Adapter	2	METAL
6	Terminal cover	1	METAL
7	Inspection panel	1	METAL

Unit: mm

A	B	C	D	E	F	G	H	I	CONNECTER DUCT DIMENSION
416	376	441	485	272	136	195	211	70	Φ 200

FV25NS3

Panasonic Ecology Systems Guangdong Co., Ltd.

Specification Data Sheet

Issue date: 2009.05.22

Revise date: 2009.06.19

Cabinet Fan Model No. FV-25NS3

Dimension

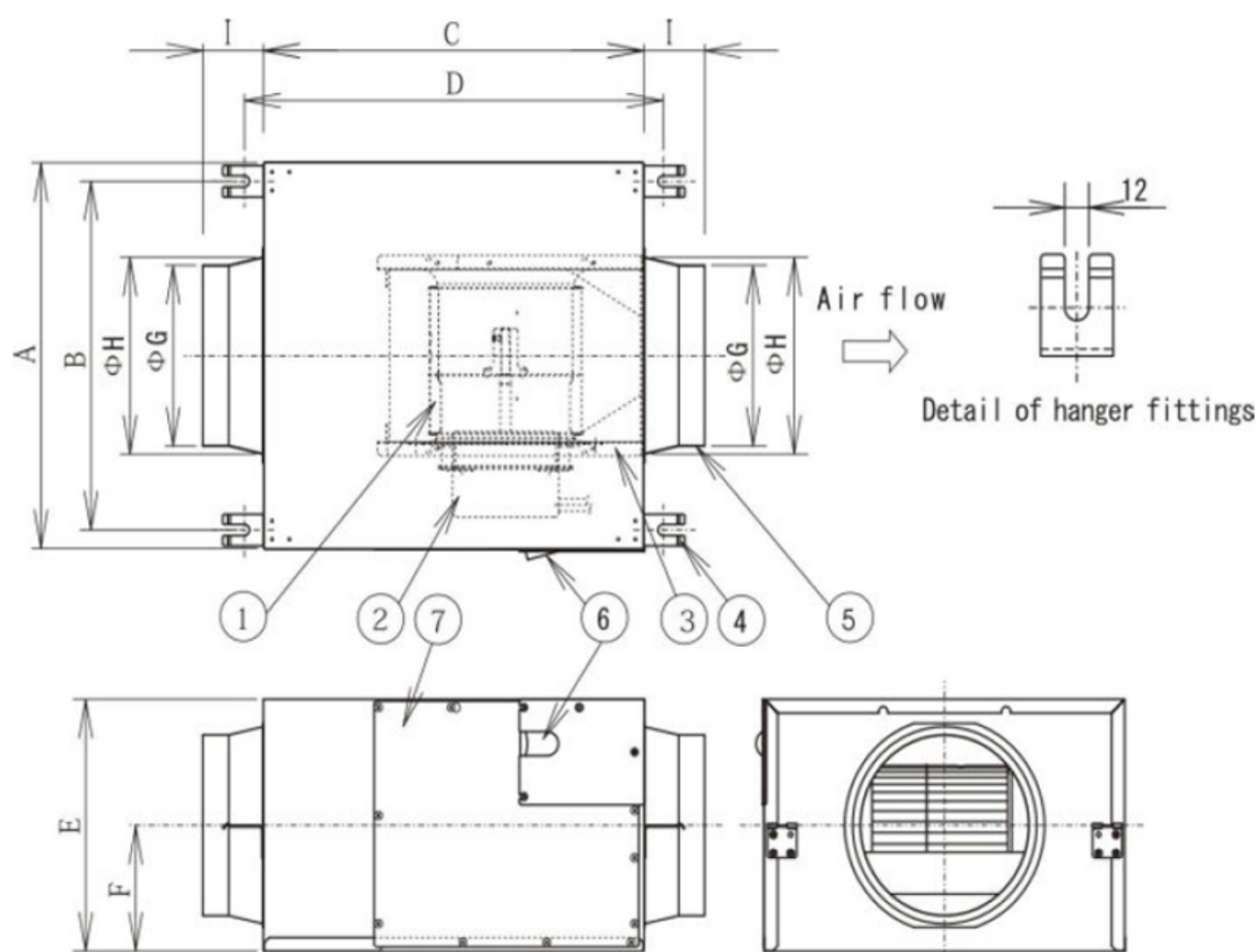

Parts list

No.	Parts name	Q'ty	Material
1	Impeller	1	METAL
2	Motor	1	-
3	Fan casing	1	METAL
4	Hanger fitting	4	METAL
5	Adapter	2	METAL
6	Terminal cover	1	METAL
7	Inspection panel	1	METAL

Unit: mm

A	B	C	D	E	F	G	H	I	CONNECTER DUCT DIMENSION
494	450	505	549	334	167	240	255	85	Φ250

FV18NF3

Panasonic Ecology Systems Guangdong Co., Ltd.

Specification Data Sheet

Issue date: 2009.05.22

Revise date: 2009.06.19

Cabinet Fan Model No. FV-18NF3

Parts list

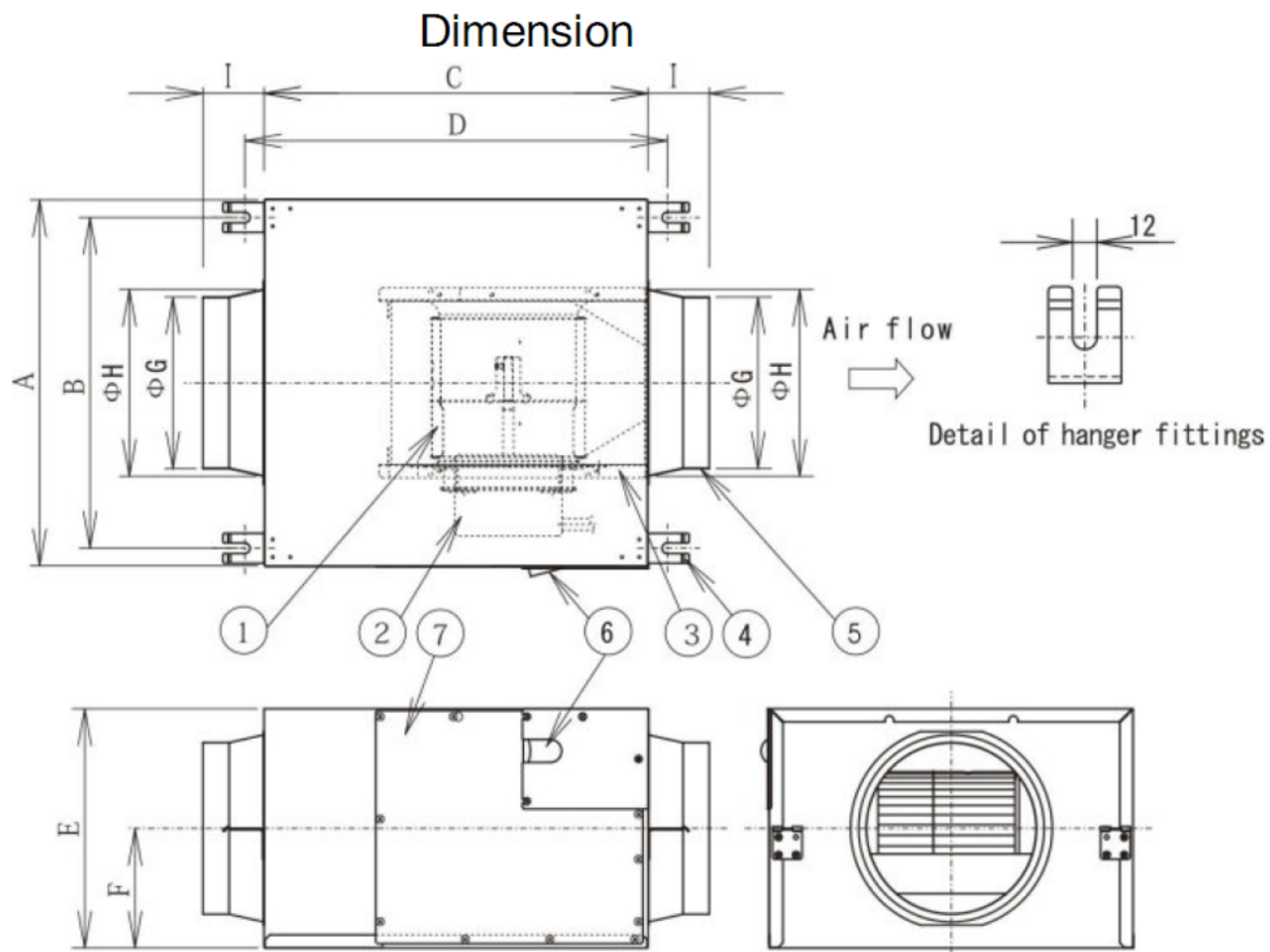

No.	Parts name	Q'ty	Material
1	Impeller	1	METAL
2	Motor	1	-
3	Fan casing	1	METAL
4	Hanger fitting	4	METAL
5	Adapter	2	METAL
6	Terminal cover	1	METAL
7	Inspection panel	1	METAL

Unit: mm

A	B	C	D	E	F	G	H	I	CONNECTER DUCT DIMENSION
376	336	397	441	254	127	195	211	70	Φ200

FV25NF3

Panasonic Ecology Systems Guangdong Co., Ltd.

Specification Data Sheet

Issue date: 2009.05.22
Revise date: 2009.06.19

Cabinet Fan Model No. FV-25NF3

Dimension

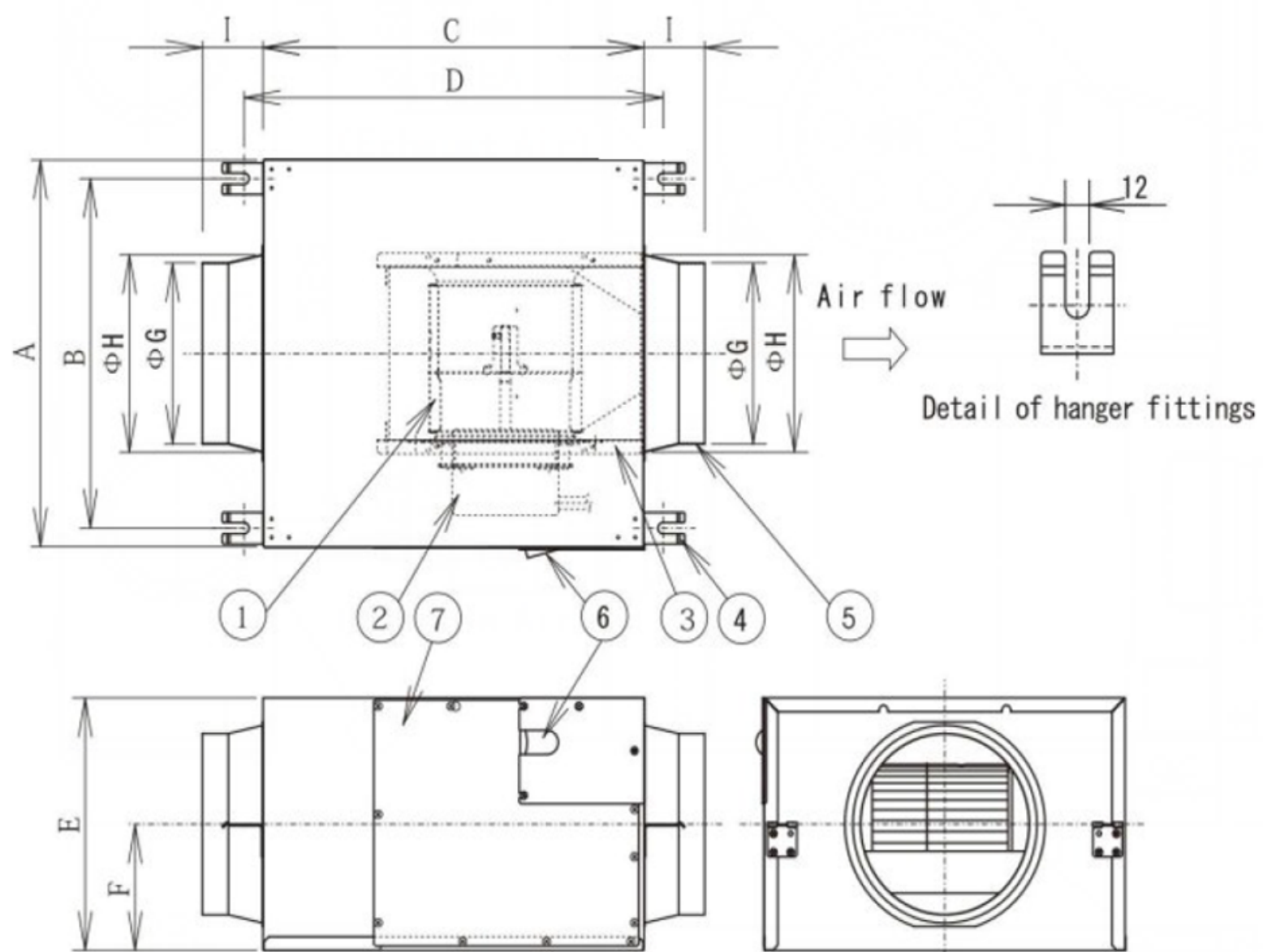

Unit: mm

A	B	C	D	E	F	G	H	I	CONNECTER DUCT DIMENSION
494	450	505	549	334	167	240	255	85	Φ250

Parts list

No.	Parts name	Q'ty	Material
1	Impeller	1	METAL
2	Motor	1	-
3	Fan casing	1	METAL
4	Hanger fitting	4	METAL
5	Adapter	2	METAL
6	Terminal cover	1	METAL
7	Inspection panel	1	METAL

FV23NL3

Panasonic Ecology Systems Guangdong Co., Ltd.

Specification Data Sheet

Issue date: 2009.05.22

Revise date: 2009.06.19

Cabinet Fan Model No. FV-23NL3

Dimension

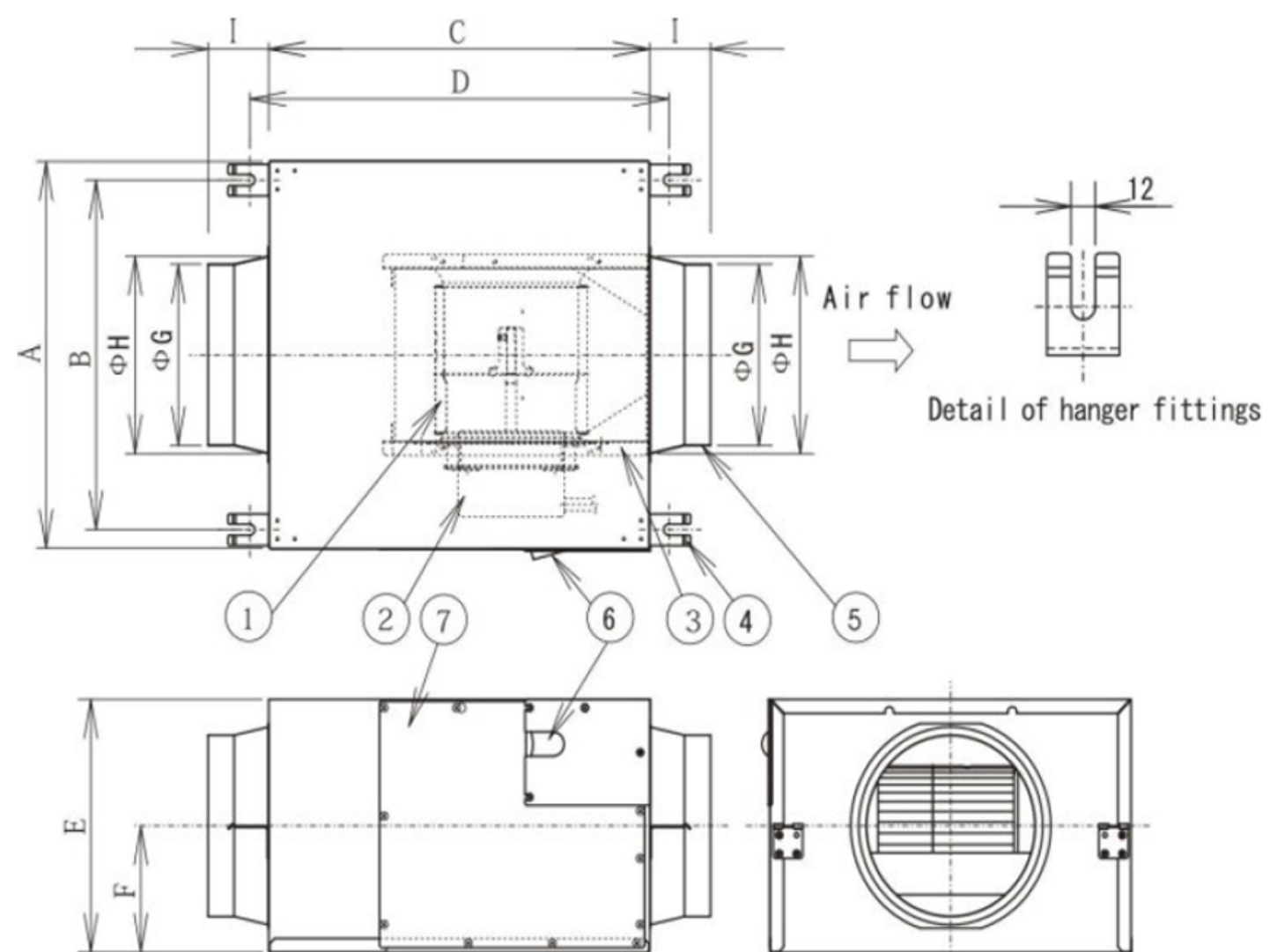

Parts list

No.	Parts name	Q'ty	Material
1	Impeller	1	METAL
2	Motor	1	-
3	Fan casing	1	METAL
4	Hanger fitting	4	METAL
5	Adapter	2	METAL
6	Terminal cover	1	METAL
7	Inspection panel	1	METAL

Unit: mm

A	B	C	D	E	F	G	H	I	CONNECTER DUCT DIMENSION
468	424	469	513	298	149	195	211	70	Φ 200

FV28NX3

Panasonic

技术标准书 Specification Data Sheet

Dimension

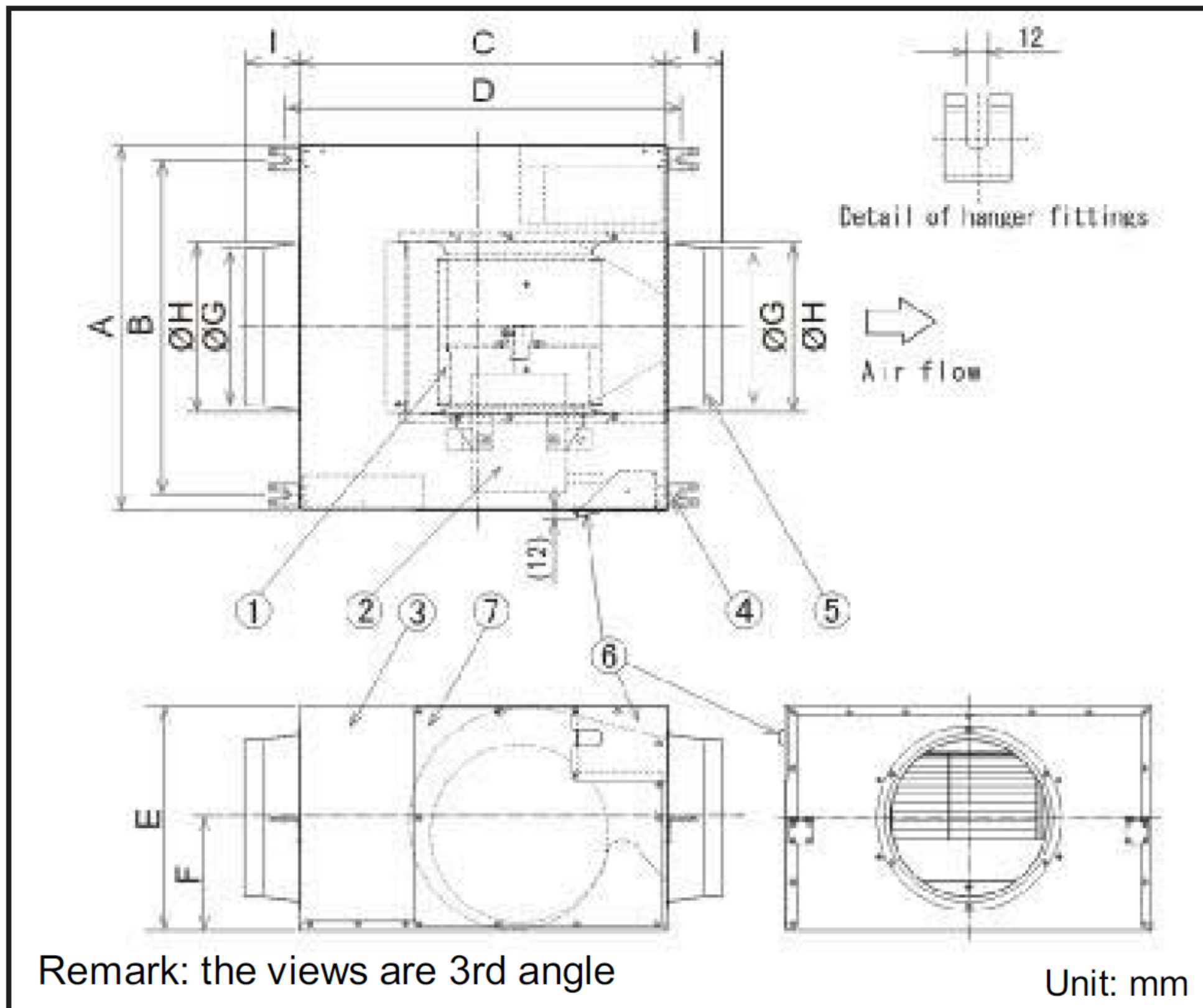

Parts List

No.	Part name	Q'ty	Material
1	Impeller	1	Metal
2	Motor	1	—
3	Frame	1	Metal
4	Hanger fitting	4	Metal
5	Adapter	2	Metal
6	Terminal cover	1	Metal
7	Inspection panel	1	Metal

A	B	C	D	E	F	G	H	I	Connector Duct Dimension
554	510	557	601	342	171	240	255	85	Φ250

FV25SM3

Panasonic

技术标准书 Specification Data Sheet

Dimension

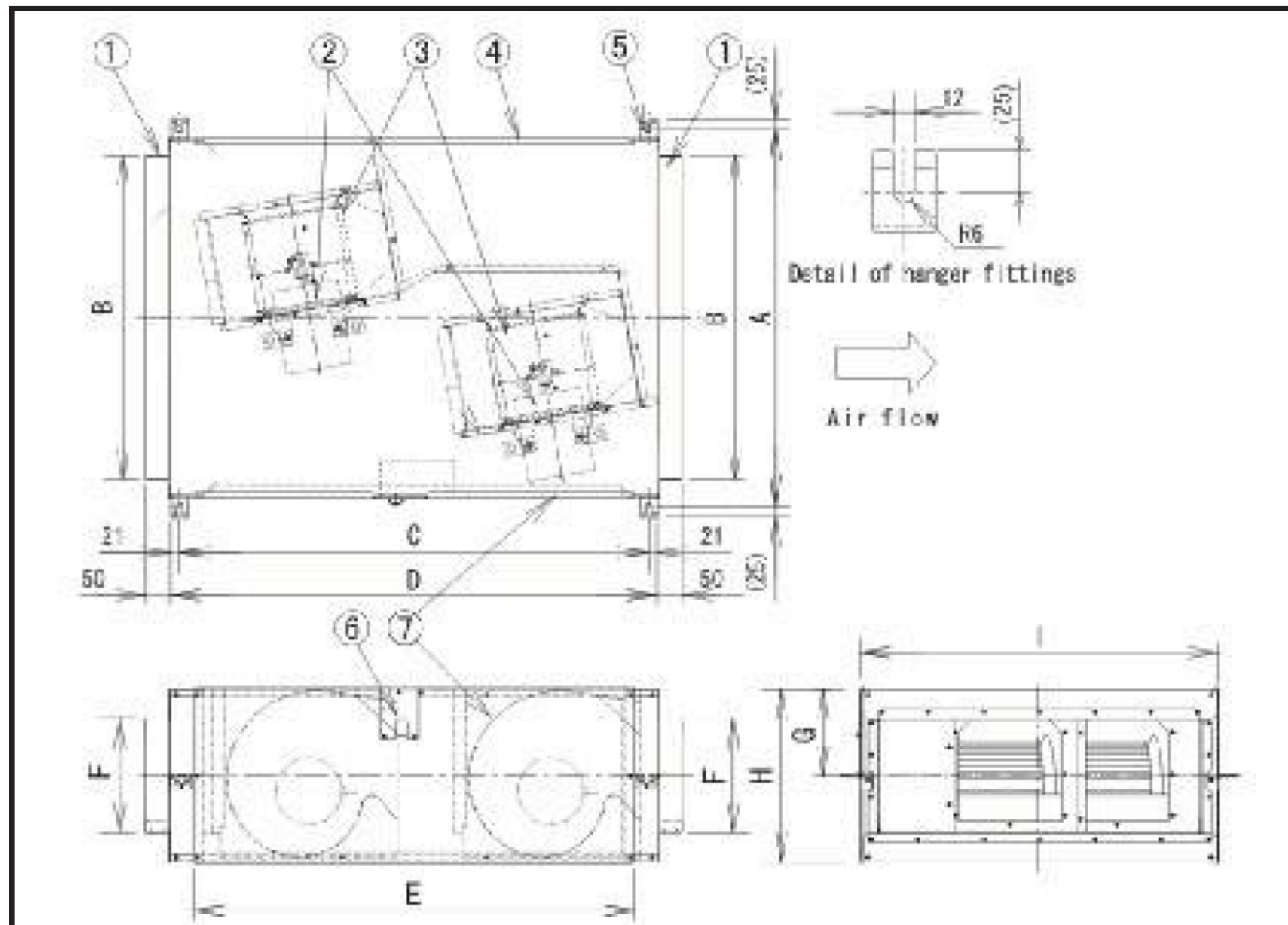

Remark: the views are 3rd angle

Unit: mm

A	B	C	D	E	F	G	H	I	Connector Duct Dimension
809	696	1010	1052	942	246	185	370	766	250×700

Parts List

No.	Part name	Q'ty	Material
1	Adapter	2	Metal
2	Motor	2	—
3	Impeller	2	Metal
4	Frame	1	Metal
5	Hanger fitting	4	Metal
6	Terminal cover	1	Metal
7	Inspection panel	1	Metal

FV25SW3

Panasonic

技术标准书 Specification Data Sheet

Dimension

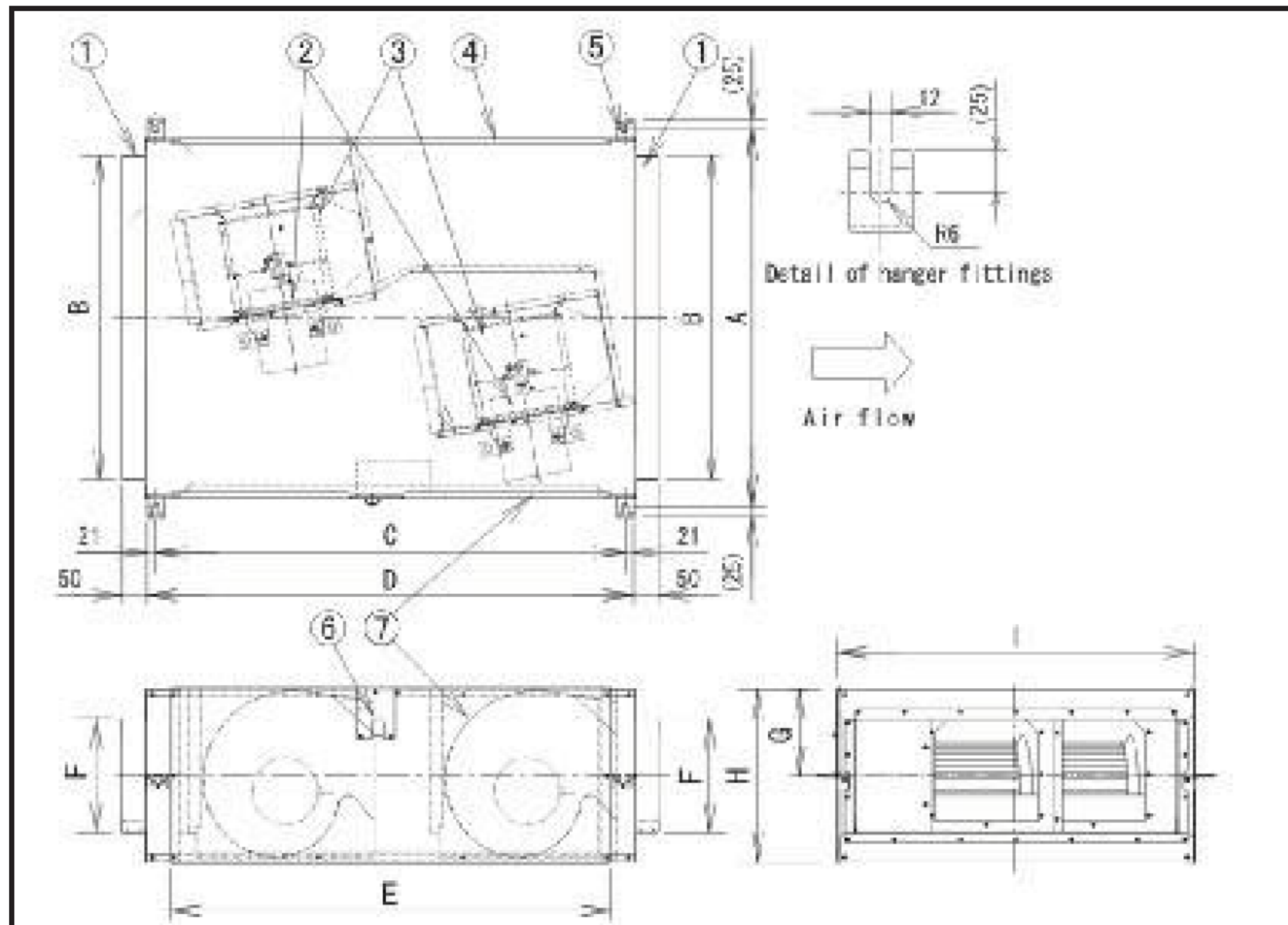

Remark: the views are 3rd angle

Unit: mm

A	B	C	D	E	F	G	H	I	Connector Duct Dimension
809	496	1010	1052	942	246	185	370	766	250×500

Parts List

No.	Part name	Q'ty	Material
1	Adapter	2	Metal
2	Motor	2	—
3	Impeller	2	Metal
4	Frame	1	Metal
5	Hanger fitting	4	Metal
6	Terminal cover	1	Metal
7	Inspection panel	1	Metal